



# SERVICE MANUAL

VHF MOBILE TRANSCEIVERS

**IC-F5021**  
**IC-F5022**  
**IC-F5023/H**  
**IC-F5026/H**  
**IC-F5028H**

---

---

---

S-14524XZ-C1  
Feb. 2009

**Icom Inc.**

---

## INTRODUCTION

This service manual describes the latest technical information for the **IC-F5021 IC-F5022 IC-F5023/H IC-F5026/H IC-F5028H** VHF MOBILE TRANSCEIVERS at the time of publication.

MODEL	VERSION	CHANNEL SPACING	TX POWER	FREQUENCY RANGE
F5021	[USA-01]	12.5/25.0	50 W	136–174 MHz
F5022	[EUR-01]	12.5/20.0/ 25.0	25 W	
F5023	[EXP-01]	12.5/25.0	50 W	
F5023H	[EXP-02]		25 W	
F5026	[RUS-01]		50 W	
F5026H	[RUS-02]		25 W	
F5028H	[CHN-01]		50 W	136–174 MHz

### UNIT ABBREVIATIONS:

F=FRONT UNIT  
M=MAIN UNIT

## CAUTION

**NEVER** connect the transceiver to an AC outlet or to a DC power supply that uses more than specified. This will ruin the transceiver.

**DO NOT** expose the transceiver to rain, snow or any liquids.

**DO NOT** reverse the polarities of the power supply when connecting the transceiver.

**DO NOT** apply an RF signal of more than 20 dm (100 mW) to the antenna connector. This could damage the transceiver's front-end.

To upgrade quality, any electrical or mechanical parts and internal circuits are subject to change without notice or obligation.



## ORDERING PARTS

Be sure to include the following four points when ordering replacement parts:

1. 10-digit Icom parts numbers
2. Component name
3. Equipment model name and unit name
4. Quantity required

### <ORDER EXAMPLE>

1110003491 S.IC TA31136FNG IC-F5021 MAIN UNIT 5 pieces  
8820001210 Screw 2438 screw IC-F5023H Top cover 10 pieces

Addresses are provided on the inside back cover for your convenience.

## REPAIR NOTES

1. Make sure that the problem is internal before disassembling the transceiver.
2. **DO NOT** open the transceiver until the transceiver is disconnected from its power source.
3. **DO NOT** force any of the variable components. Turn them slowly and smoothly.
4. **DO NOT** short any circuits or electronic parts. An insulated tuning tool **MUST** be used for all adjustments.
5. **DO NOT** keep power ON for a long time when the transceiver is defective.
6. **DO NOT** transmit power into a Standard Signal Generator or a Sweep Generator.
7. **ALWAYS** connect a 50 dB to 60 dB attenuator between the transceiver and a Deviation Meter or Spectrum Analyzer when using such test equipment.
8. **READ** the instructions of test equipment thoroughly before connecting a test equipment to the transceiver.

Icom, Icom Inc. and ICOM logo are registered trademarks of Icom Incorporated (Japan) in the United States, the United Kingdom, Germany, France, Spain, Russia and/or other countries.

---

## TABLE OF CONTENTS

---

<b>SECTION 1</b>	<b>SPECIFICATIONS</b>	
<b>SECTION 2</b>	<b>INSIDE VIEWS</b>	
<b>SECTION 3</b>	<b>DISASSEMBLY INSTRUCTION</b>	
<b>SECTION 4</b>	<b>OPTIONAL UNIT INSTALLATION</b>	
<b>SECTION 5</b>	<b>CIRCUIT DESCRIPITON</b>	
5-1	RECEIVER CIRCUITS.....	5-1
5-2	TRANSMITTER CIRCUITS.....	5-3
5-3	FREQUENCY SYNTHESIZER CIRCUITS.....	5-4
5-4	VOLTAGE DIAGRAM.....	5-4
5-5	PORT ALLOCATIONS.....	5-5
<b>SECTION 6</b>	<b>ADJUSTMENT PROCEDURE</b>	
6-1	PREPARATION.....	6-1
6-2	FREQUENCY ADJUSTMENT.....	6-4
6-3	TRANSMIT ADJUSTMENT.....	6-5
6-4	RECEIVE ADJUSTMENT.....	6-6
<b>SECTION 7</b>	<b>PARTS LIST</b>	
<b>SECTION 8</b>	<b>MECHANICAL PARTS</b>	
<b>SECTION 9</b>	<b>BOARD LAYOUTS</b>	
<b>SECTION 10</b>	<b>GENERAL WIRING</b>	
<b>SECTION 11</b>	<b>BLOCK DIAGRAM</b>	
<b>SECTION 12</b>	<b>VOLTAGE DIAGRAM</b>	

# SECTION 1

# SPECIFICATIONS

		[USA], [RUS], [CHN], [EXP]	[EUR]	
GENERAL	• Frequency coverage	136–174 MHz [USA], [CHN], [EXP] 146–174 MHz [RUS]	136–174 MHz	
	• Type of emission	Wide	16K0F3E (25.0 kHz)	
		Middle	–	14K0F3E (20.0 kHz)
		Narrow	11K0F3E (12.5 kHz)	8K50F3E (12.5 kHz)
	• Number of programable channels	128 channels (8 zones)		
	• Antenna impedance	50 Ω (nominal)		
	• Operating temperature range	–30°C to +60°C (–22°F to +140°F)	–25°C to +55°C	
	• Power supply requirement (nominal)	13.6 V DC (Negative ground)		13.2 V DC (Negative ground)
	• Current drain (approx.)	RX	Stand-by	300 mA
			Max.audio	1200 mA
		TX	at 25 W	7.0 A
			at 50 W	14.0 A
• Dimensions (projections not included)	[25 W ver.]	150 (W) × 40 (H) × 117.5 (D) mm; (5 <sup>29/32</sup> (W) × 1 <sup>9/16</sup> (H) × 4 <sup>5/8</sup> (D) in)		
	[50 W ver.]	150 (W) × 40 (H) × 167.5 (D) mm; (5 <sup>29/32</sup> (W) × 1 <sup>9/16</sup> (H) × 6 <sup>19/32</sup> (D) in)	–	
• Weight	[25 W ver.]	0.8 kg (1 <sup>3/4</sup> lb)	0.8 kg	
	[50 W ver.]	1.1 kg (2 <sup>7/16</sup> lb)	–	
TRANSMITTER	• Transmit output power	[25 W ver.]	25 W (High), 10 W (Low2), 2.5 W (Low1)	
		[50 W ver.]	50 W (High), 25 W (Low2), 5.0 W (Low1)	
	• Modulation	Variable reactance frequency modulation		
	• Max. permissible deviation	Wide	±5.0 kHz	
		Middle	–	±4.0 kHz
		Narrow	±2.5 kHz	
	• Frequency error	±2.5 ppm		±1.5 kHz
	• Spurious emission	70 dB typ.		0.25 μW (≤1 GHz), 1.0 μW (>1 GHz)
	• Adjacent channel power	Wide	70 dB min.	
		Middle	–	70 dB min.
		Narrow	60 dB min.	
	• Audio frequency response	+1 dB to –3 dB of 6 dB/octave (from 500–2500 Hz)		
	• Audio harmonic distortion	3% typ. (with 1 kHz AF 40% deviation)		
	• FM hum and noise (without CCITT filter)	Wide	More than 40 dB (46 dB typ.)	–
		Narrow	More than 34 dB (40 dB typ.)	–
	• Residual modulation (with CCITT filter)	Wide	–	More than 45 dB (55 dB typ.)
		Middle	–	More than 43 dB (53 dB typ.)
		Narrow	–	More than 40 dB (50 dB typ.)
• Limiting charact of modulation	70–100% of max. deviation			
• Microphone impedance	600 Ω			

		[USA], [RUS], [CHN], [EXP]	[EUR]	
<b>RECEIVER</b>	• Receive system	Double-conversion superheterodyne		
	• Intermediate frequencies	1st IF; 46.35 MHz, 2nd IF; 450 kHz		
	• Sensitivity	0.25 $\mu$ V typ. at 12 dB SINAD	-4 dB $\mu$ V (EMF) typ. at 20 dB SINAD	
	• Squelch sensitivity (at threshold)	0.25 $\mu$ V typ.	-4 dB $\mu$ V (EMF) typ.	
	• Adjacent channel selectivity	Wide	More than 70 dB (75 dB typ.) Other than [RUS] 82 dB typ. [RUS]	
		Middle	-	More than 70 dB (75 dB typ.)
		Narrow	More than 60 dB (65 dB typ.)	
	• Spurious response	70 dB min.		
	• Intermodulation	More than 70 dB (75 dB typ.)	More than 65 dB (67 dB typ.)	
	• FM hum and noise (without CCITT filter)	Wide	More than 40 dB (45 dB typ.)	-
		Narrow	More than 34 dB (40 dB typ.)	-
	• Residual modulation (with CCITT filter)	Wide	-	More than 45 dB (55 dB typ.)
		Middle	-	More than 43 dB (53 dB typ.)
		Narrow	-	More than 40 dB (50 dB typ.)
	• Audio output power	4.0 W typ. at 5% distortion with a 4 $\Omega$ load		
• Audio output impedance	4 $\Omega$			

# SECTION 2

# INSIDE VIEWS

## • FRONT UNIT (TOP VIEW)

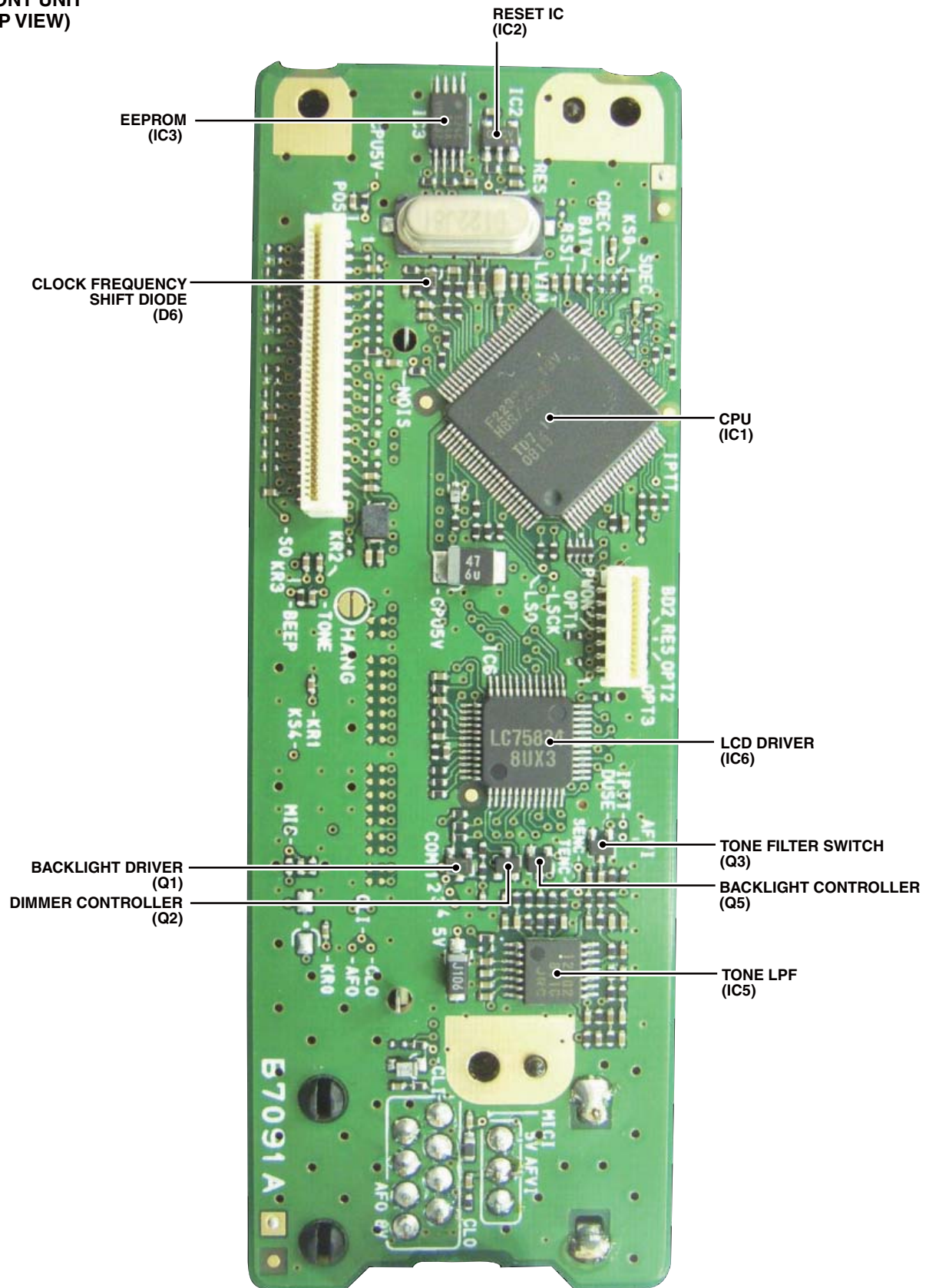



• MAIN-A UNIT  
(TOP VIEW)

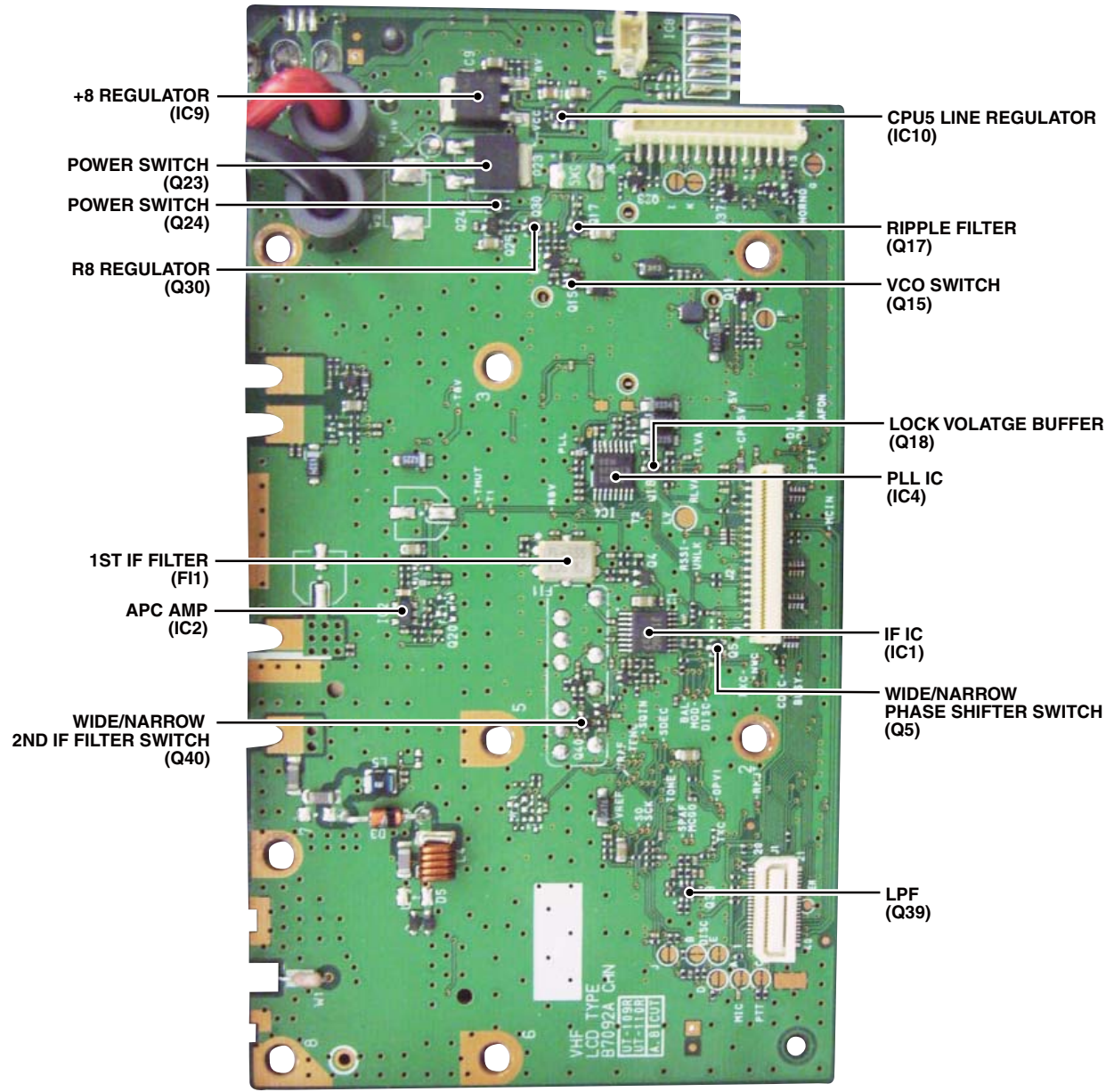

• MAIN-A UNIT  
(BOTTOM VIEW)

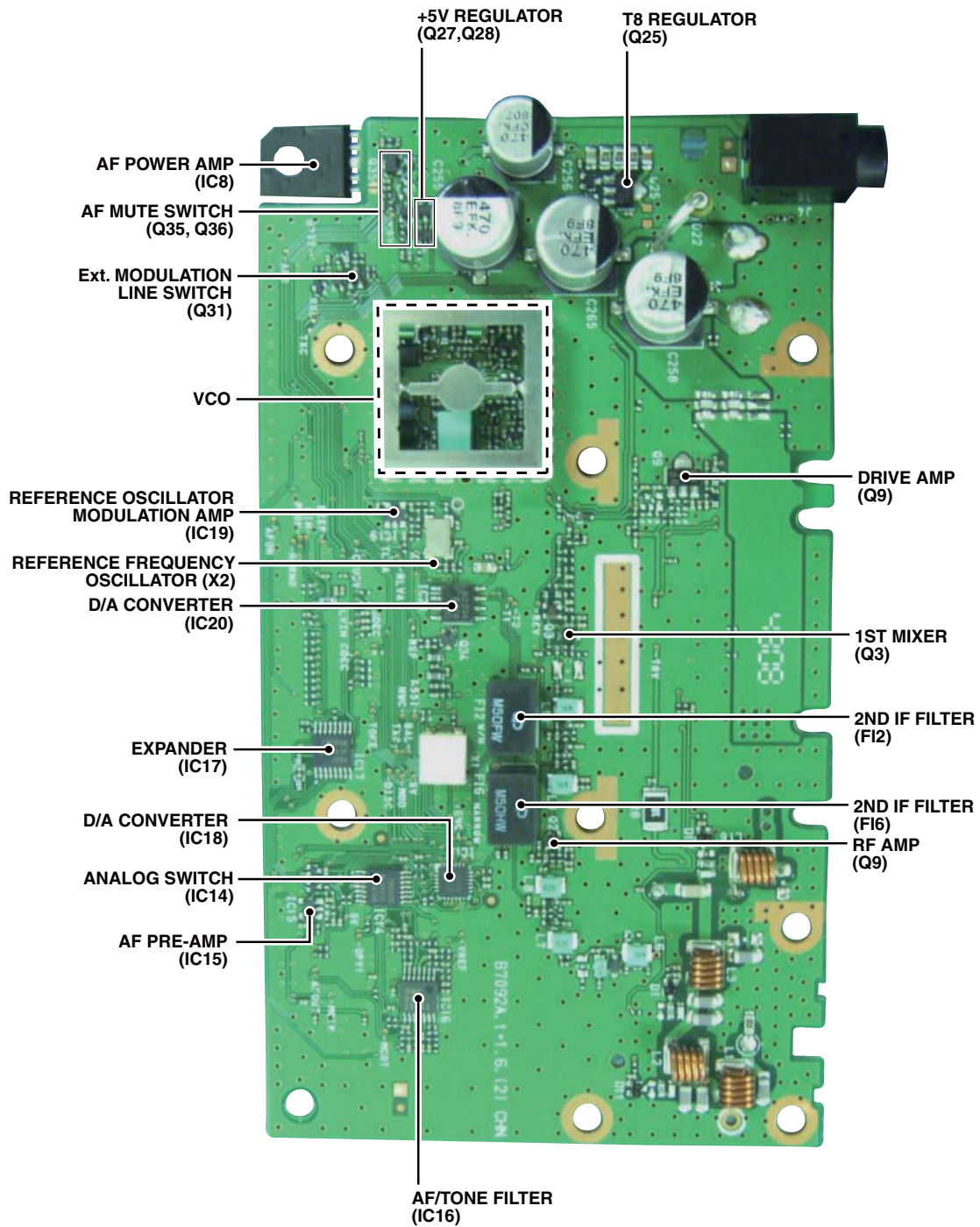



## SECTION 3 DISASSEMBLY INSTRUCTION

- 1) Unscrew 4 screws from the top cover, and remove the top cover.
- 2) Disconnect the flat cable and speaker cable.
- 3) Unscrew 2 screws from the both sides, and remove the front panel in the direction of the arrow.

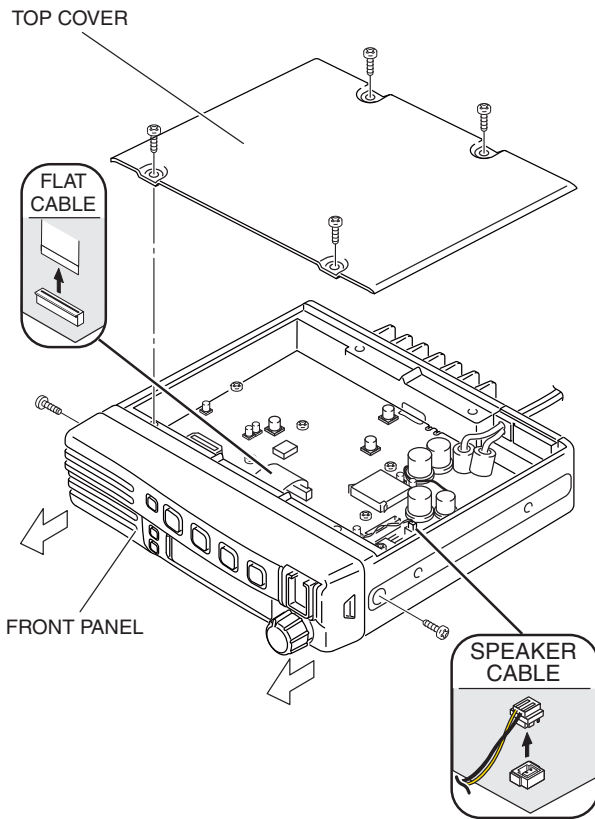

- 6) Unsolder total of 9 points; 3 points at the antenna connector, 6 points at the PA module.

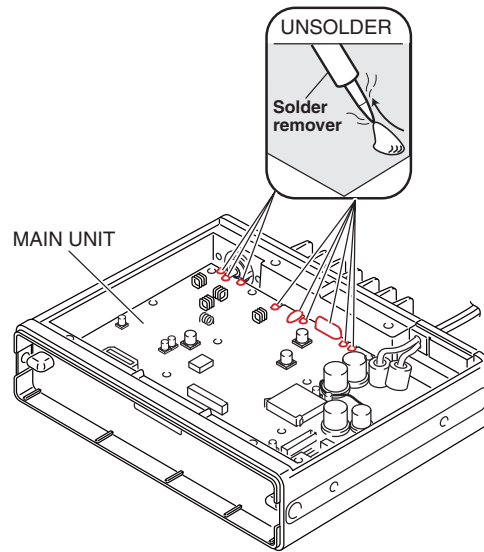

- 7) Take off the MAIN UNIT from the CHASSIS.

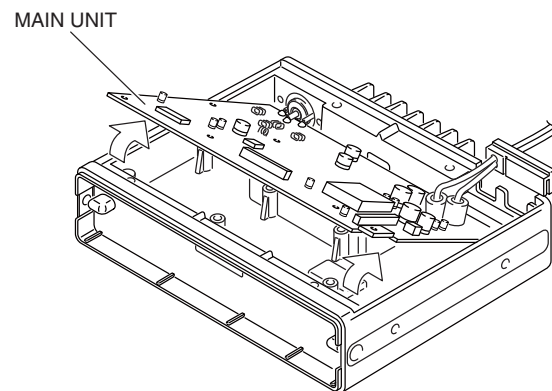

- 5) Unscrew 9 screws from the MAIN UNIT.

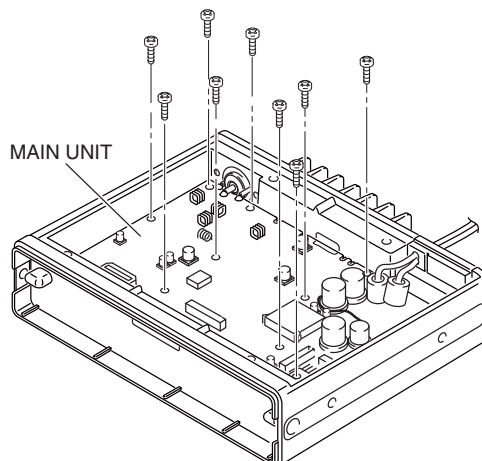

# SECTION 4 OPTIONAL PRODUCTS INSTALLATION

## Install optional UT-108 as follows;

- 1) Turn the transceiver OFF, then disconnect the DC cable.
- 2) Unscrew 4 screws, then remove the bottom cover.
- 3) Install the unit as shown below.
- 4) Recover the bottom cover, screws and DC power cable.

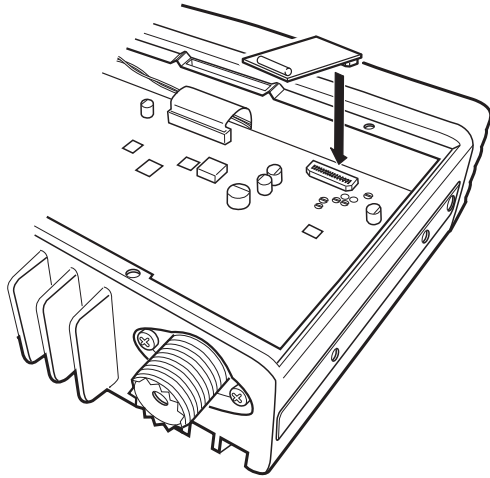

## Install optional UT-109R or UT-110R as follows;

- 1) Turn the transceiver OFF, then disconnect the DC power cable.
- 2) Unscrew 4 screws, then remove the bottom cover.
- 3) Cut the pattern on the PCB at "MIC" and "DISC" as shown below.
- 4) Install the unit as shown below.
- 5) Recover the bottom cover, screws and DC power cable.

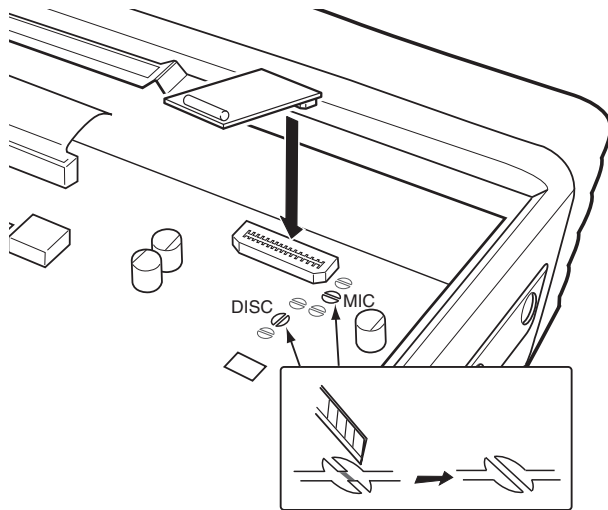

## Install optional OPC-1939 as follows;

- 1) Turn the transceiver OFF, then disconnect the DC power cable.
- 2) Unscrew 4 screws, then remove the bottom cover.
- 3) Install the cable as shown below.

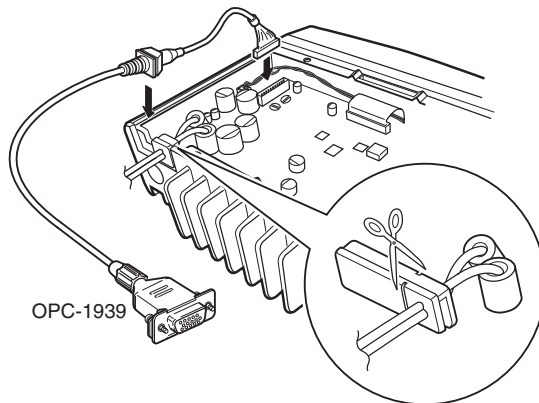

Cut off the bushing as in the illustration, when you install the optional OPC-1939.

- 4) Cut or short the patterns as below. (For AF output)

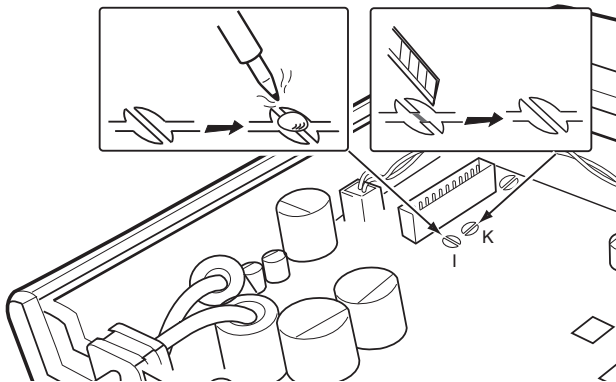

- 5) Short the pattern as below. (For modulation input)

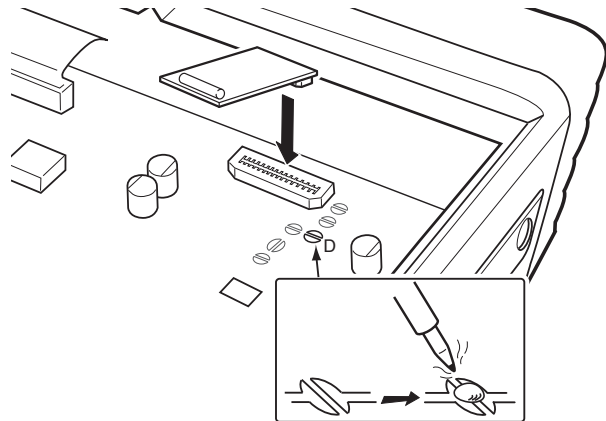

- 6) Recover the bottom cover, screws and DC power cable.

**NOTE:** Be sure to recover the patterns when you remove the optional product. Otherwise no TX modulation or AF output is available.

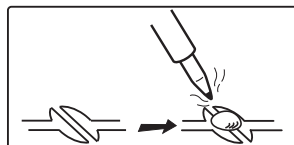
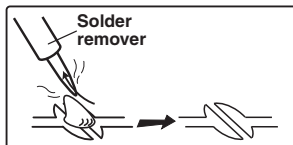

## 5-1 RECEIVER CIRCUITS

### RF CIRCUITS

RF signals from the antenna are passed through the LPF (as the harmonic filter for transmitting) and antenna SW, then applied to the RX BPF circuit.

The applied RX signals are passed through the 2-staged tuned BPF (D4, D8) to remove unwanted out-of-band signals, and amplified by the low-noise RF AMP (Q2), then applied to the 1st mixer (Q3) via another 2-staged tuned BPF (D9, 10).

Total of 4 stage BPF are tuned to the RX frequency by the tuning voltage "T1" and "T2" from the D/A converter (IC20), to obtain required IMD characteristic.

### • RF CIRCUITS

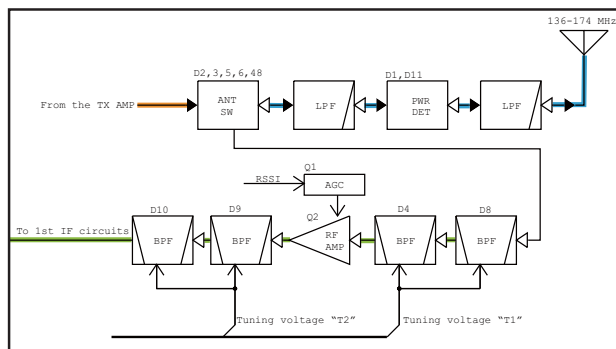

### 1ST IF CIRCUITS

The RX signals from the BPF are mixed with the 1st LO signals to be converted into the 46.35 MHz 1st IF signal.

The 1st LO signals are generated by the RX VCO (Q14, D33, D34, L26, L39, etc.), and passed through the LO SW (D15) and attenuator, then applied to the 1st mixer (Q3)

The converted 1st IF signal is filtered by the crystal filter (FI1) and amplified by the 1st IF AMP (Q4), then applied to the IF IC (IC1).

### • 1ST IF CIRCUITS

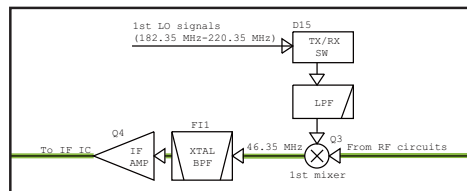

### 2ND IF AND DEMODULATOR CIRCUITS

The amplified 1st IF signal is mixed with the 2nd LO signal at the internal 2nd IF mixer of the IF IC (IC1), to obtain the 450 kHz 2nd IF signal.

The 15.3 MHz signal generated by the reference oscillator (X2) is passed through the filter AMP (Q34, L33, 35, C305-308) to extract the 45.9 MHz 3rd harmonic component. The 45.9 MHz signal is then applied to pin 2 of IF IC (IC1) as the 2nd LO signal.

The converted 2nd IF signal is output from pin 3 of IF IC (IC1), and filtered by the ceramic filters (FI2 and FI6 for Narrow mode; FI2 only for Wide mode) to remove unwanted out-of-band signals, then applied to the internal frequency-demodulator of IF IC (IC1) from pin 5.

The demodulator is a quadrature type which uses X1 as the phase shifter.

The frequency-demodulated AF signals are output from pin 9 to AF circuits.

### • 2ND IF AND DEMODULATOR CIRCUITS

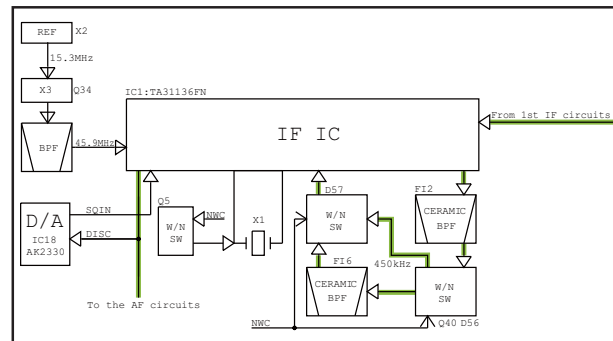

## AF CIRCUITS

The demodulated AF signals from the IF IC (IC1) are amplified and filtered by the HPF (IC16), and passed through the AF line SW (IC14) and LPF (IC16). The filtered AF signals are adjusted its level (=loudness) by the D/A converter (IC18), and applied to the AF AMP (IC15) via the AF line SW (IC14).

The amplified AF signals are applied to the AF power AMP (IC8) and power-amplified to obtain AF output level.

The power-amplified AF signals are applied to the internal speaker on the FRONT UNIT or output from the external speaker jack on the rear panel.

## SIGNALING (DECODING)

Demodulated signals from pin 9 of the IF IC (IC1) are passed through the LPF to extract tone signals contained in the demodulated signals.

2/5 tone signals are extracted by the LPF (IC16). CTCSS/DTCS signals are extracted by the LPF (Q39).

These extracted tone signals are applied to the CPU (FRONT UNIT: IC1) for decoding.

## • RX AF CIRCUITS

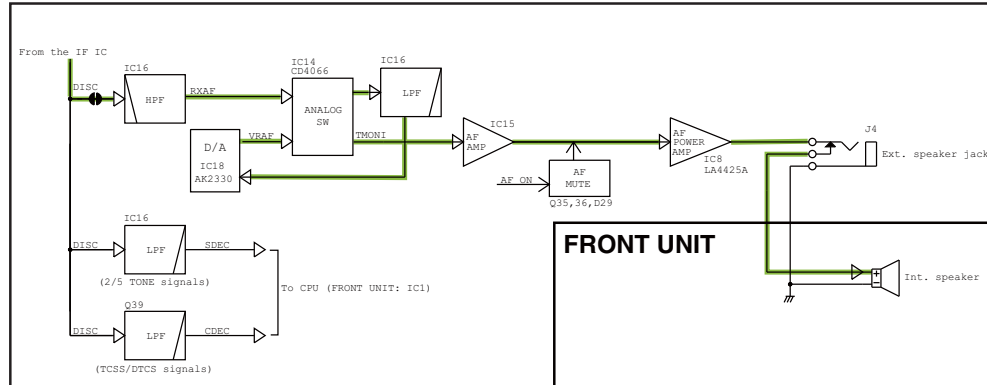

## 5-2 TRANSMITTER CIRCUITS

### MIC AMPLIFIER (FRONT UNIT)

Audio signals from the connected microphone are applied to the MIC AMP (IC5) via the microphone connector (J1). The amplified MIC signals are applied to the MAIN UNIT.

### TX AF CIRCUITS

The MIC signals from the FRONT UNIT are passed through the D/A converter (as a MIC gain controller; IC18) for level adjustment, and applied to the limiter AMP which is also rolled to the pre-emphasis circuit (IC16).

#### • TX AF CIRCUITS

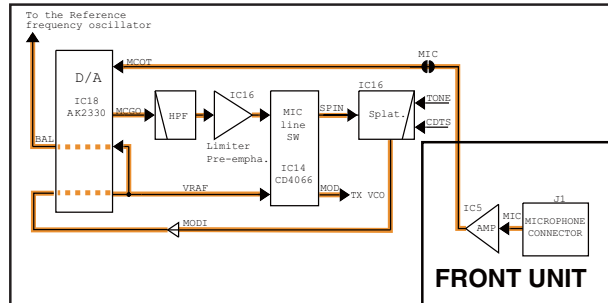

### MIC MUTE SWITCH

The pre-emphasized MIC signals are passed through the MIC mute SW (IC14).

While receiving, the MIC mute SW (IC14) cuts the MIC line off, and is controlled by "MMUT" signal from the expander (IC17).

### SPLATTER FILTER

The MIC signals from the MIC mute SW (IC14) are applied to the splatter filter (IC16).

The splatter filter (IC16) is also used as the AF Summing AMP for tone signals modulation (CTCSS, 2/5 TONE).

### MODULATION CIRCUIT

MIC signals from the splatter filter (IC16) is level-adjusted (=deviation adjustment) by the D/A converter (IC18), and applied to the TX VCO (Q13, D16, 31) via modulation mute SW (IC14) as the modulation signals.

The MIC signals are also applied to the reference frequency oscillator (X2) as the modulation signals via D/A converter (IC18) and REF AMP (IC19).

#### • MODULATION CIRCUITS

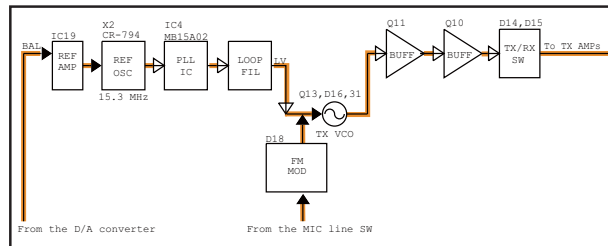

### CTCSS/DTCS SIGNALS ENCODING (FRONT UNIT)

The CTCSS/DTCS encoding signals from the CPU (IC1) "CENC0-CENC2" are passed through the LPF (IC5) for waveform conversion, and applied to the MAIN UNIT as tone modulation signals.

### 2/5 TONE, DTMF ENCODING (FRONT UNIT)

Encoding signal from the CPU (IC1) named "SENC" is passed through the LPF (IC5), and applied to the MAIN UNIT as tone modulation signals.

### TX AMPLIFIERS

The frequency-modulated signal from the TX VCO is buffer-amplified by two buffers (Q11 and Q10), and applied to the drive AMP (Q9) as the TX signal via the LO SW (D14). The amplified TX signal is applied to the FET HPA module (IC3) via the LPF, and power-amplified to obtain TX output power level.

The power-amplified TX signal is passed through the antenna SW (D3) and LPF as a harmonic filter, then fed to the antenna.

### APC CIRCUIT

A portion of TX signal rectified by D1, D11 and D12 on the TX line to detect TX power level. The rectified voltage is applied to the APC AMP (IC2), and the APC AMP controls the gain of HPA module (IC3) automatically by comparing the rectified voltage and the power setting voltage "T1."

#### • TX AMPLIFIERS APC CIRCUIT

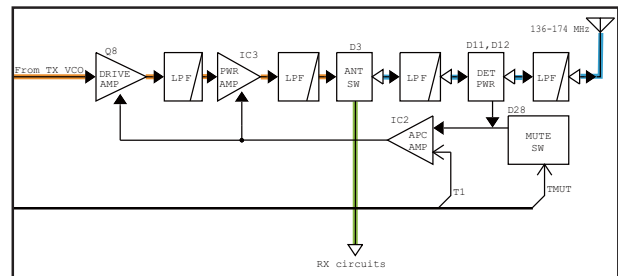



### 5-3 FREQUENCY SYNTHESIZER CIRCUITS

#### VCOs

The TX VCO which generates TX signal is composed by Q13, D16, D31, L25, L38, etc., and the frequency modulation is carried out by applying modulation signals to D18.

The RX VCO which generates 1st LO signals is composed by Q14, D33, D34, L26, L39, etc.

These two VCOs are switched by the VCO SW (Q15, 16) using "RXC" signal.

The output signals from each VCO are amplified by the buffer AMP (Q11) and LO AMP (Q10), then applied to the TX or RX circuits.

A portion of oscillated signals is applied to the PLL IC (IC4) via buffer AMP (Q12).

#### PLL

The applied VCO output is divided according to the serial data including divide ratio from the CPU, at the prescaler and programmable divider. In the same way, the reference frequency signal from the reference frequency signal oscillator is applied to the PLL IC and divide so that these are the same frequency.

The frequency-matched signals are applied to the phase comparator and phase-compared. The resulted phase difference is detected as a phase-type signal, and level-adjusted at the charge pump then output. The output pulse type signal is passed through the loop filter to be converted into the DC voltage (=Lock Voltage).

Applying the lock voltage to the variable capacitors (VD) which composes a part of the resonator of VCO, the capacitance of VDs changes corresponding to the applied lock voltage. This causes the change of resonance frequency that determines the VCO oscillating frequency to keep the VCO frequency constant.

When the oscillation frequency drifts, its phase changes from that of the reference frequency, causing a lock voltage change to compensate for the drift in the VCO oscillating frequency.

#### • FREQUENCY SYNTHESIZER CIRCUITS

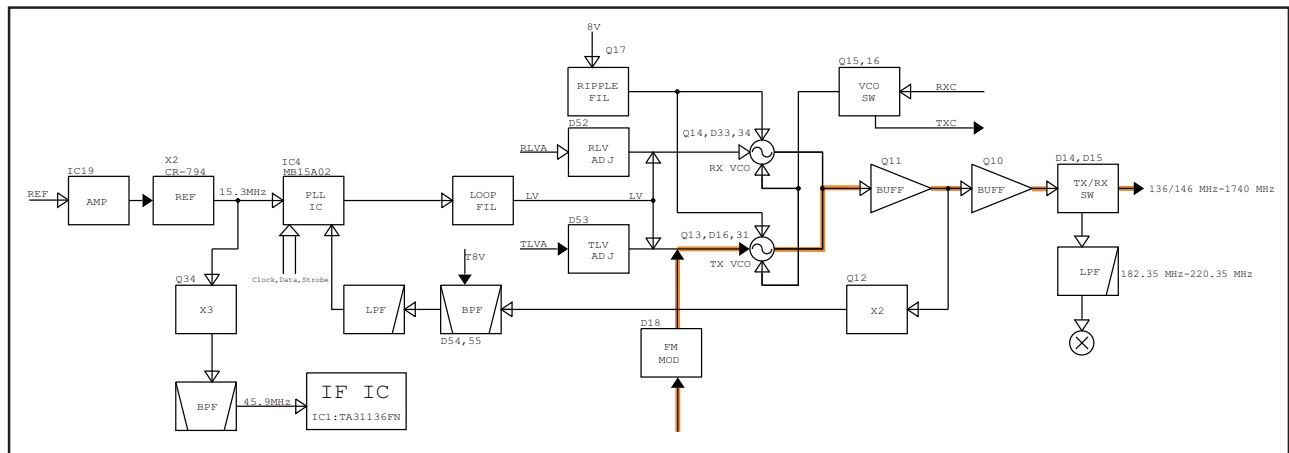

### 5-4 VOLTAGE DIAGRAM

Voltage from the power supply is routed to the whole of the transceiver via regulators and switches.

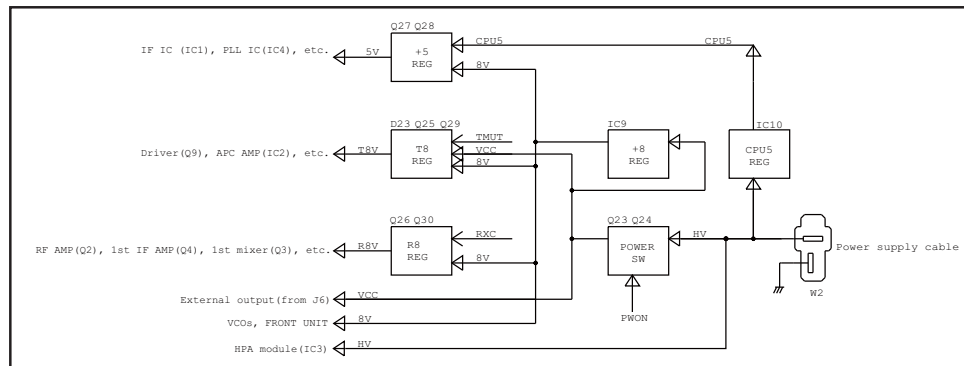

## 5-5 PORT ALLOCATIONS

### 5-5-1 CPU (FRONT UNIT; IC1)

Pin No.	Port Name	Description
1-3	KR1-KR3	Input ports for dealer-programmable keys.
4-8	KS0-KS4	Output ports for dealer-programmable keys.
10	CCS	Outputs chip-select signal to the attached optional unit.
19-21	CENC0-CENC2	Output ports for CTCSS/DTCS signal.
23	DUSE	Frequency response of tone filter (FRONT UNIT; IC5) switching signal. "Low"=While transmitting.
24	IPTT	PTT input from connected microphone. "Low"=PTT is pushed.
25	HANG	Microphone on/off hook detect. "Low"=The microphone is off hook.
30	PLST	Outputs PLL strobe signal to the PLL IC (MAIN UNIT; IC4, pin 11).
34	ULCK	Input port for PLL unlock detect signal from the PLL IC (MAIN UNIT; IC4, pin 7). "Low"=While the PLL circuit is unlocked.
39	DSDA	Outputs serial data to the D/A converter (MAIN UNIT; IC20, pin 6).
43	SENC	Outputs DTMF signals to the LPF (FRONT UNIT; IC5, pin 3).
44	BEEP	Outputs beep sounds to the LPF (FRONT UNIT; IC5, pin 7).
45	SDEC	Input port for DTMF signals.
46	CDEC	Input port for CTCSS/DTCS signals.
48	BATV	Input port for power supply voltage.
49	LVIN	Input port for VCO lock voltage.
50	RSSI	Input port for receive signal strength level signal from the IF IC (MAIN UNIT; IC1, pin 12).
51	TEMP	Voltage divided by thermal register (MAIN UNIT; R209) and R210. (temperature monitor)
52	AFVI	[VOL] dial (FRONT UNIT; R14) input. (divided voltage of 5V line)
59	RES	Input port for CPU reset signal from the reset IC (FRONT UNIT; IC8, pin 1). "Low"=When the CPU is reset.
69	CSFT	Outputs CPU clock shift signal to the clock frequency shift switch (FRONT UNIT; D6).
71	DAST	Outputs strobe signal to the D/A converter (MAIN UNIT; IC18, pin 7).
72	IGSW/ DIM	• Ignition SW control input. Or • Dimmer control input.
75	NOIS	Input port for noise signal from the IF IC (MAIN UNIT; IC1, pin 13).
79	CLO	Cloning data output.
80	CLI	Cloning data input.
82	ESDA	Outputs serial data to the EEPROM (FRONT UNIT; IC3, pin 5).
85	ESCL	Outputs clock signal to the EEPROM (FRONT UNIT; IC3, pin 6).
86	PWON	Transceiver's power control. "High"=Power ON.
91	LSO	Outputs serial data to the LCD driver (FRONT UNIT; IC6, pin 48).
92	LSCK	Outputs clock signal to the LCD driver (FRONT UNIT; IC6, pin 47).
93	LCS	Outputs chip-enable signal to the LCD driver (FRONT UNIT; IC6, pin 46).
94	LINH	Outputs display inhibit signal to the LCD driver (FRONT UNIT; IC6, pin 45).
95	LIGT2	Outputs LCD backlight control signal to the backlight LEDs (FRONT UNIT; DS1-9) driver (FRONT UNIT; Q5). "High"=While the backlight is ON.

Pin No.	Port Name	Description
98	SCK	Outputs serial clock signal to the PLL IC (IC4, pin 9) and D/A converters (IC17, pin 3/IC18, pin 8/IC20, pin 7).
99	SO	Outputs serial data to the PLL IC (IC4, pin 9) and D/A converters (IC17, pin 3/IC18, pin 8/IC20, pin 7).
100	KR0	Input ports for dealer-programmable keys.

### 5-5-2 EXPANDER (MAIN UNIT; IC17)

Pin No.	Line Name	Description
1	EXST	Strobe (load enable) input.
2	SO	Serial data input.
3	SCK	Serial clock input.
4	RXC	T8V, R8V lines and RX VCO ON/OFF control.
5	AFON	AF mute SW (Q35) control. "Low"=Mute
6	NWC	• RX band width switching signal to the 2nd IF filter SW (D56, 57). "Low"=Narrow mode • RX band width switching signal to the phase shifter SW (Q5). "Low"=Wide mode
7	RMUT	Outputs AF mute signal to the analog switch (IC3, pins 12, 13). "Low"=While the squelch is close or transmitting.
12	HORNO	External device control. "Low"=Pin 6 of OPC-1939 (if connected) is "Low."
13	TMUT	Outputs transmit mute signal to the transmit mute switch (Q46). "High"=Transmitting is muted.

### 5-5-3 D/A CONVERTER (MAIN UNIT; IC18)

Pin No.	Description
2, 3	MIC signal level adjustment.
4, 5	RX AF/MIC signal level adjustment.
16, 17	Tone signal level adjustment.
18, 19	Oscillation frequency control voltage to the reference frequency oscillator (X2).
20, 21	Modulation signal level adjustment.
22, 23	Beep sound loudness adjustment.
24, 25	Squelch threshold level adjustment.

### 5-5-4 D/A CONVERTER (MAIN UNIT; IC20)

Pin No.	Line Name	Description
1	T1	• <b>While receiving</b> Tuning voltage to the tuned BPF (D4, 8). • <b>While transmitting</b> TX power level setting signal to the APC AMP IC2).
2	T2	Tuning voltage to the tuned BPF (D9, 10).
3	TLVA	Oscillation frequency correcting voltage to the TX VCO (Q13, D16, 18, 31, 53).
4	RLVA	Oscillation frequency correcting voltage to the RX VCO (Q14, D33, 34, 52).

# SECTION 6 ADJUSTMENT PROCEDURE

## 6-1 PREPARATION

### REQUIRED EQUIPMENTS

EQUIPMENT	GRADE AND RANGE	EQUIPMENT	GRADE AND RANGE
Cloning Software	CS-F5020 : Revision 1.0 or later	JIG Cable	Modified OPC-1122U (see the illust below)
DC Power Supply	Output voltage : 13.6 V DC except [EUR] 13.2 V DC [EUR] Current capacity : More than 20 A	Attenuator	Power attenuation : 40 or 50 dB Capacity : 30 W [25 W ver.] 60 W [50 W ver.]
Modulation Analyzer	Frequency range : DC–300 MHz Measuring range : 0 to ±10 kHz	External Speaker	Input impedance : 4 Ω Capacity : 20 W or more
Frequency Counter	Frequency range : 0.1–300 MHz Frequency accuracy : ±1 ppm or better Sensitivity : 100 mV or better	Standard Signal Generator (SSG)	Frequency range : 0.1–300 MHz Output level : 0.1 μV to 32 mV (–127 to –17 dBm)
RF Power Meter	Measuring range : 0.1–30 W [25 W ver.] 0.1–60 W [50 W ver.] Frequency range : 100–300 MHz Impedance : 50 Ω SWR : Better than 1.2 : 1	Oscilloscope	Frequency rang : DC–20 MHz Measuring range : 0.01–20 V

### JIG CABLE

OPC-1122U (USB type Cloning cable)

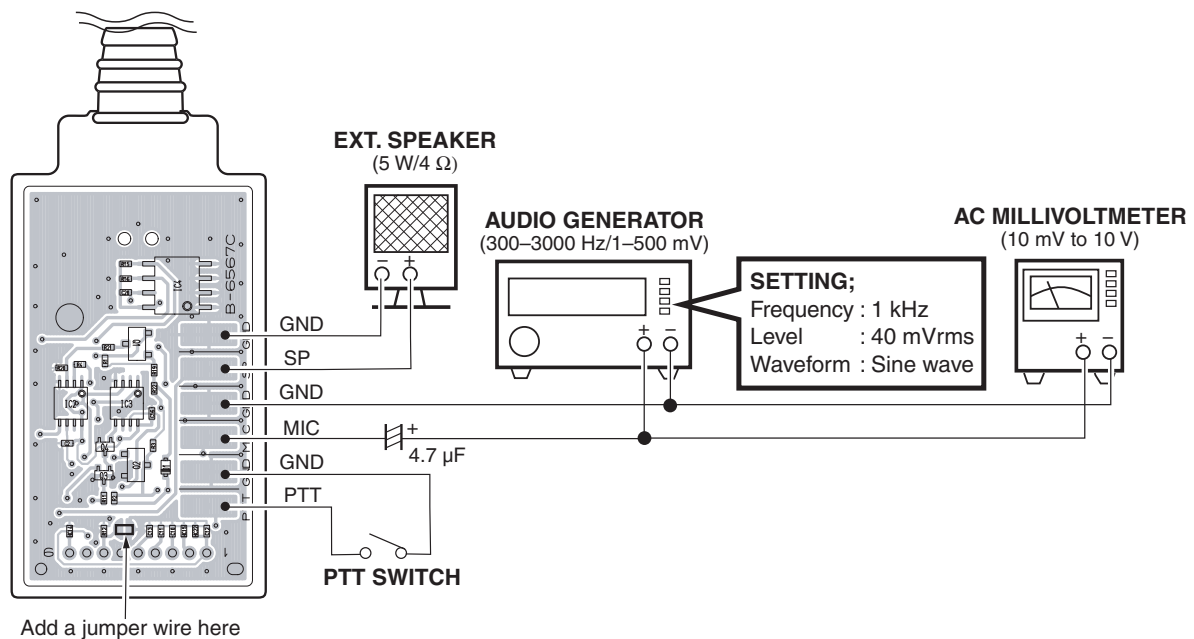

## ADJUSTMENT FREQUENCIES

Before starting adjustment, clone adjustment frequencies and settings into the transceiver as below.

• For except [F5026]

CH	Frequency (MHz)						C.Tone		Text	TOT	RF PWR	PWR Save	Lock-out	
	Atr	Inh	RX	TX	TX Inh	W/N	SQL Tight	RX						TX
1- 1	AB		136.000000	<-		W				LV ADJ		L1	ON	
1- 2			174.000000	<-		W				LV VERIFY		L1	ON	
1- 3			174.000000	<-		W				REF FREQ		L1	ON	
1- 4			155.000000	<-		W				TXPWR H.		H	ON	
1- 5			155.000000	<-		W				TXPWR L2		L2	ON	
1- 6			155.000000	<-		W				TXPWR L1		L1	ON	
1- 7			155.000000	<-		W			007N	BAL		L1	ON	
1- 8			155.000000	<-		N				MOD N		H	ON	
1- 9			155.000000	<-		W				MOD W		H	ON	
1- 10			155.000000	<-		W				MOD M		H	ON	
1- 11			155.000000	<-		W			250.3	CTC/DTC		H	ON	
1- 12			136.100000	<-	i	W				BPF		H	ON	
1- 13			136.100000	<-	i	W				RSSI		H	ON	
1- 14			136.100000	<-	i	W				SQL		H	ON	
1- 15														

**NOTE: FOR [F5022],** when adjust “Deviation,” “Modulation Balance,” “RX SENSITIVITY” and “S-meter” in the middle band, change the bandwidth to “Middle” as below.

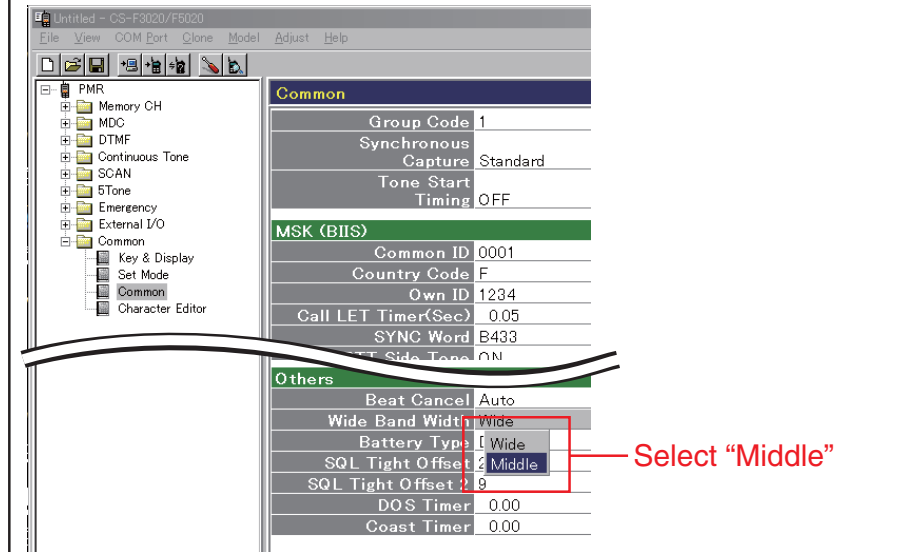

• For [F5026]

CH	Frequency (MHz)						C.Tone		Text	TOT	RF PWR	PWR Save	Lock-out	
	Atr	Inh	RX	TX	TX Inh	W/N	SQL Tight	RX						TX
1- 3			174.000000	<-		W				REF FREQ		L1	ON	
1- 4			160.000000	<-		W				TXPWR H.		H	ON	
1- 5			160.000000	<-		W				TXPWR L2		L2	ON	
1- 6			160.000000	<-		W				TXPWR L1		L1	ON	
1- 7			160.000000	<-		W			007N	BAL		L1	ON	
1- 8			160.000000	<-		N				MOD N		L1	ON	
1- 9			160.000000	<-		W				MOD W		L1	ON	
1- 10			160.000000	<-		W				MOD M		L1	ON	
1- 11			160.000000	<-		W			250.3	CTC/DTC		L1	ON	
1- 12			146.100000	<-	i	W				BPF		L1	ON	
1- 13			146.100000	<-	i	W				RSSI		L1	ON	
1- 14			146.100000	<-	i	W				SQL		L1	ON	
1- 15														

## CONNECTION

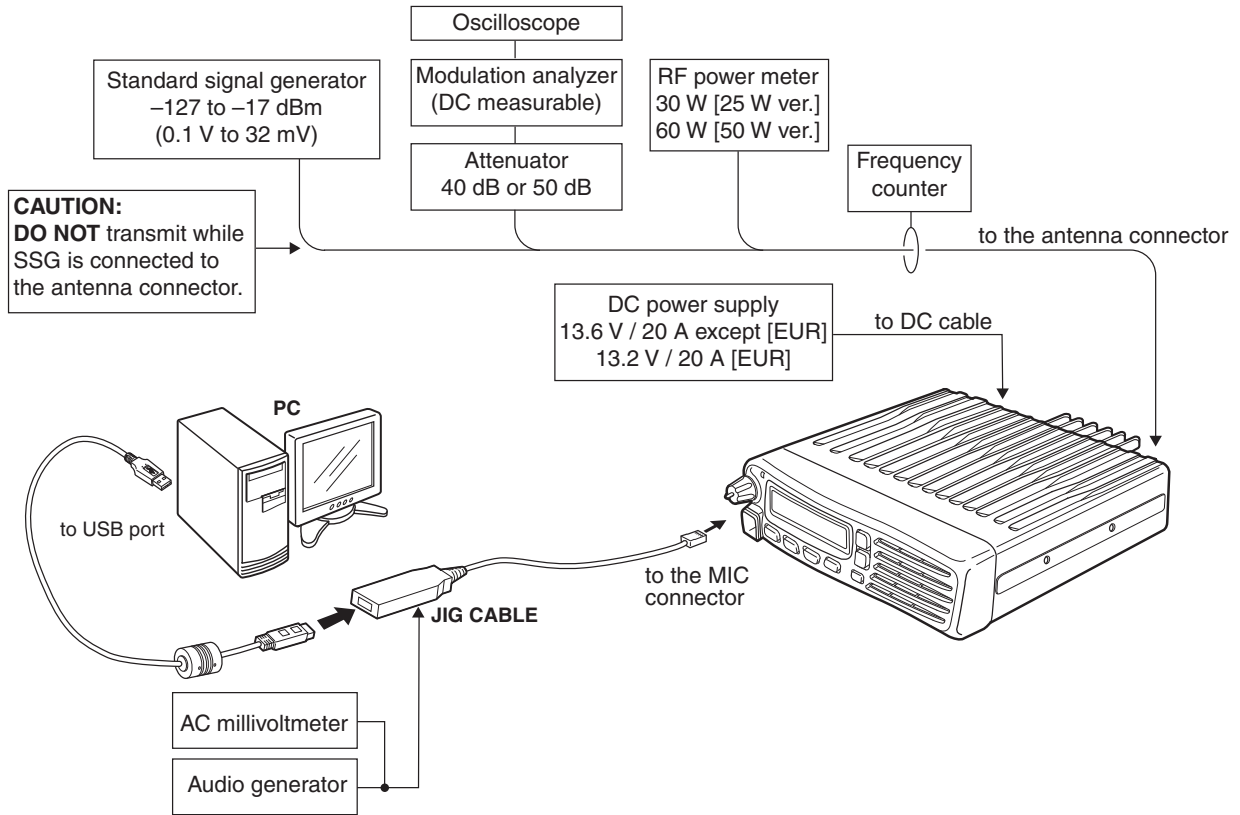

## ADJUSTMENT UTILITY WINDOW (example)

Click to open the "I/O Check window"

Parameter	Value	Range	Action
Setting			
CH No.	2		
RX=155.10000, TX=155.10000 RF Power=High, Mode=Narrow			
Adjust			
Power (Hi)	174	[#####-----]	
Power (L2)	103	[#####-----]	
Power (L1)	49	[###-----]	
BAL	128	[#####-----]	
MOD N	119	[#####-----]	
MOD Ratio	117	[#####-----]	
CTCS/DTCS	118	[#####-----]	
SQL	40	[###-----]	
REF	126	[#####-----]	
BPF ALL			[Enter] to Sweep
BPF T1	45	[###-----]	[Enter] to Sweep
BPF T2	69	[#####-----]	[Enter] to Sweep
RX LVA	95	[#####-----]	[Enter] to Sweep
TX LVA	143	[#####-----]	[Enter] to Sweep
LV(RX LVA)	56	1.10V	
LV(TX LVA)	54	1.06V	
RSSI	86	[Enter] to Capture	

ADJ. CHANNEL

TX POWER

MOD. BALANCE

DEVIATION

CTCSS/DTCS

SQUELCH

REF. FREQUENCY

RX SENSITIVITY

LOCK VOLTAGE

RSSI (S3 and S1 level)



## 6-2 FREQUENCY ADJUSTMENT

- 1) Select an adjustment item using cursor or [↑] / [↓] keys of the PC's keyboard.
- 2) Set or modify the adjustment value as specified using [←] / [→] keys of the PC's keyboard, then push the [ENTER] key.

ADJUSTMENT	ADJUSTMENT CONDITION	OPERatio	VALUE
PLL LOCK VOLTAGE -adjustment- [RX LVA]	1 • Channel : 1-1 • Receiving	Select the item [RX LVA], then adjust the voltage (LVIN) using [←] / [→] keys of the PC's keyboard.	1.1 V Other than [F5026], [F5026H]  1.7 V [F5026], [F5026H]
[TX LVA]	2 • Channel : 1-1 • Transmitting	Select the item [TX LVA], then adjust the voltage (LVIN) using [←] / [→] keys of the PC's keyboard.	1.06 V Other than [F5026], [F5026H]  1.4 V [F5026], [F5026H]
PLL LOCK VOLTAGE -verification-	1 • Channel : 1-2 • Receiving	Click [Reload (F5)] button, then check the "LVIN" item on the "I/O Check window."	3.0–4.0 V
	2 • Channel : 1-2 • Transmitting		2.5–3.5 V
REFERENCE FREQUENCY [REF]	1 • Channel : 1-3 • Connect an RF power meter to the antenna connector. • Transmitting	Loosely couple a frequency counter to the antenna connector.	174.000000 MHz

### • I/O Check window

I/O Check			
Input	Dec	Hex	Data
VIN	182	B6	14.27V
TEMPS	186	BA	30.35°C
LVIN	106	6A	2.08V
SD	23	17	0.45V
Output	Dec	Hex	Data
BPF T1	120	78	2.35V
T2/POW	144	90	2.82V
REF	129	81	2.53V
MOD BAL	128	80	50.20%
Dev	0	0	0.00V
CTCSS	107	6B	2.10V
SQL Lev	22	16	0.43V
TXLVA	112	70	2.20V
RXLVA	160	A0	3.14V

Lock voltage

(The values shown in the above screen are example only.  
Each transceiver has their own values.)

### 6-3 TRANSMIT ADJUSTMENT

1) Select an adjustment item using cursor or [↑] / [↓] keys of the PC's keyboard.

2) Set or modify the adjustment value as specified using [←] / [→] keys of the PC's keyboard, then push the [ENTER] key.

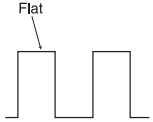
ADJUSTMENT	ADJUSTMENT CONDITION	OPERatio	VALUE
<b>OUTPUT POWER</b> [Power (Hi)]	1 • Channel : 1-4 • Transmitting	Connect an RF power meter to the antenna connector.	25 W [25W ver.] 50 W [50 W ver.]
[Power (L2)]	2 • Channel : 1-5 • Transmitting		10 W [25W ver.] 25 W [50 W ver.]
[Power (L1)]	3 • Channel : 1-6 • Transmitting		2.5 W [25W ver.] 5.0 W [50 W ver.]
<b>MODULATION BALANCE</b> [BAL]	1 • Channel : 1-7 • No audio signals applied to the JIG cable. • Set a modulation analyzer as; HPF : OFF LPF : 20 kHz De-emphasis : OFF Detector : (P-P)/2 • Transmitting.	Connect the Modulation Analyzer with an oscilloscope to the antenna connector through an attenuator.	Set to square waveform 
<b>DEVIATION - PREPARATION-</b>	1 • Connect an audio generator to the JIG cable and set as; Frequency : 1.0 kHz Level : 40 mVrms • Set the modulation analyzer to the same condition as "MODULATION BALANCE."	Connect a Modulation Analyzer with an oscilloscope to the antenna connector through an attenuator.	—
<b>(NARROW)</b> [MOD N]	2 • Channel : 1-8 • Transmitting		±2.05 to ±2.15 kHz
<b>(WIDE)</b> [MOD Ratio]	3 • Channel : 1-9 • Transmitting		±4.05 to ±4.15 kHz
<b>(MIDDLE)*</b> [MOD Ratio]	4 • Channel : 1-10 • Transmitting		±3.25 to ±3.35 kHz
<b>CTCSS/DTCS DEVIATION</b> [CTCSS/DTCS]	1 • Channel : 1-11 • No audio signals applied to the JIG cable. • Set the Modulation Analyzer to the same condition as "MODULATION BALANCE." • Transmitting	Connect a Modulation Analyzer with an oscilloscope to the antenna connector through an attenuator.	±0.65 to ±0.75 kHz

\*: [EUR] only

## 6-4 RECEIVE ADJUSTMENT

1) Select an adjustment item using cursor or [↑] / [↓] keys of the PC's keyboard.

2) Set or modify the adjustment value as specified using [←] / [→] keys of the PC's keyboard, then push the [ENTER] key.

ADJUSTMENT	ADJUSTMENT CONDITION	LOCATION	VALUE
<b>RECEIVE SENSITIVITY</b> [BPF T1] [BPF T2]	<b>NOTE:</b> When "RECEIVE SENSITIVITY" is re-adjusted, "S-METER" must be re-adjusted too.		
	1 <ul style="list-style-type: none"> <li>• Channel : 1-12</li> <li>• Receiving</li> <li>• Connect the SSG to the antenna connector and set as; <ul style="list-style-type: none"> <li>Frequency : 136.100 MHz except [F5026]</li> <li>: 146.100 MHz [F5026]</li> <li>Level : +20 dBμ<sup>†</sup> (-87 dBm)</li> <li>Modulation : 1 kHz</li> <li>Deviation : ±3.5 kHz except [EUR]</li> <li>: ±2.8 kHz [EUR]</li> </ul> </li> </ul>	1) Select the item [BPF T1] then push the [ENTER] key. 2) Select the item [BPF T2] then push the [ENTER] key.	(Automatic adjustment)
<b>S-METER</b> [RSSI] (S3 level)	<b>NOTE:</b> "RECEIVE SENSITIVITY" MUST be adjusted before "S-METER." When "RECEIVE SENSITIVITY" is re-adjusted, "S-METER" MUST be re-adjusted too.		
	1 <ul style="list-style-type: none"> <li>• Channel : 1-13</li> <li>• Connect the SSG to the antenna connector and set as; <ul style="list-style-type: none"> <li>Frequency : 136.100 MHz except [F5026/H]</li> <li>: 146.100 MHz [F5026/H]</li> <li>Level : +23 dBμ<sup>†</sup> (-84 dBm)</li> <li>Modulation : 1 kHz</li> <li>Deviation : ±3.5 kHz except [EUR]</li> <li>: ±2.8 kHz [EUR]</li> </ul> </li> <li>• Receiving</li> </ul>	Select the item [RSSI S3 Level], then push the [ENTER] key to store the adjust value for S3 level.	(Automatic adjustment)
(S1 level)	2 <ul style="list-style-type: none"> <li>• Set the SSG as; <ul style="list-style-type: none"> <li>Level : -7 dBμ<sup>†</sup> (-114 dBm)</li> </ul> </li> <li>• Receiving</li> </ul>	Select the item [RSSI S1 Level], then push the [ENTER] key, to store the adjust value for S1 level.	
<b>SQUELCH</b> [SQL]	1 <ul style="list-style-type: none"> <li>• Channel : 1-14</li> <li>• Connect the SSG to the antenna connector and set as; <ul style="list-style-type: none"> <li>Frequency : 136.100 MHz except [F5026/H]</li> <li>: 146.100 MHz [F5026/H]</li> <li>Level : -13 dBμ<sup>†</sup> (-120 dBm)</li> <li>Modulation : 1 kHz</li> <li>Deviation : ±3.5 kHz except [EUR]</li> <li>: ±2.8 kHz [EUR]</li> </ul> </li> <li>• Receiving</li> </ul>	1) Once close the squelch by increasing [SQL] value, then decrease the value to open the squelch. 2) Push [ENTER] key to store the value.	(Automatic adjustment)

<sup>†</sup>; The output level of the standard signal generator (SSG) is indicated as the SSG's open circuit.

## SECTION 7

## PARTS LIST

[MAIN-A UNIT]

REF NO.	PARTS NO.	DESCRIPTION	M.	H/V LOCATION
IC1	1110003491	S.IC TA31136FNG(D,EL)	T	57.8/24.7
IC2	1110002751	S.IC TA75S01F(TE85R,F)	T	60/54.9
IC3	1150002371	IC RA30H1317M1-121 [EUR-01]		
	1150002371	IC RA30H1317M1-121 [EXP-01]		
	1150002420	IC RA60H1317M1A-101 [USA-01]		
	1150002420	IC RA60H1317M1A-101 [EXP-02]		
	1150002420	IC RA60H1317M1A-101 [CHN-01]		
IC4	1140005991	S.IC MB15A02PFV1-G-BND-ERE1	T	77.8/29.2
IC8	1110003091	IC LA4425A-E		
IC9	1180003500	S.REG NJM7808DL1A-TE1-#FZZB	T	123.3/45.7
IC10	1180003460	S.REG NJM2831F05-TE1-#ZZZB	T	121.6/35.4
IC14	1130011770	S.IC CD4066BPWR	B	35.1/16.4
IC15	1110002751	S.IC TA75S01F(TE85R,F)	B	32/6.7
IC16	1110005340	S.IC NJM12902V-TE1-#ZZZB	B	20.6/21.1
IC17	1130011760	S.IC CD4094BPWR	B	53.1/9.9
IC18	1110007290	S.IC AK2330P-L	B	35.9/25.7
IC19	1110002751	S.IC TA75S01F(TE85R,F)	B	83.7/18.1
IC20	1190001340	S.IC M62334FP 600C	B	72.3/26.3
Q1	1560000841	S.FET 2SK1829(TE85R,F)	T	33.7/39.7
Q2	1580000731	S.FET 3SK293(TE85L,F)	B	41.5/38.7
Q3	1580000800	S.FET 3SK324UG-TL-E	B	71.3/38.4
Q4	1530002601	S.TRA 2SC4215-O(TE85R,F)	T	64.5/25.3
Q5	1590000430	S.TRA DTC144EUA T106	T	55.6/15.2
Q9	1530003340	S.TRA 2SC3357-T1 RF	B	88.5/55.2
Q10	1530003260	S.TRA 2SC5006-T1	B	93.8/33.8
Q11	1530003260	S.TRA 2SC5006-T1	B	100.7/32.8
Q12	1530003260	S.TRA 2SC5006-T1	B	97.4/31
Q13	1530002920	S.TRA 2SC4222-T1 R25	B	105.4/32.9
Q14	1530002920	S.TRA 2SC4222-T1 R25	B	100.6/25.8
Q15	1590001400	S.TRA XP1214(TX)	T	101.2/34.2
Q16	1590000430	S.TRA DTC144EUA T106	T	103.6/36.6
Q17	1530002851	S.TRA 2SC4116-BL(TE85R,F)	T	107.7/33.4
Q18	1560000541	S.FET 2SK880-Y(T5RICOM,F)	T	78/24.5
Q19	1590000430	S.TRA DTC144EUA T106	T	99.5/12.9
Q20	1530002851	S.TRA 2SC4116-BL(TE85R,F) [USA-01]	T	60/49.8
	1530002851	S.TRA 2SC4116-BL(TE85R,F) [EXP-02]		
	1530002851	S.TRA 2SC4116-BL(TE85R,F) [CHN-01]		
Q23	1550000190	S.FET 2SJ506STR-E	T	115.3/45.4
Q24	1590000430	S.TRA DTC144EUA T106	T	110.5/44.3
Q25	1540000550	S.TRA 2SD1664 T100Q	B	125.1/47.6
Q26	1510000920	S.TRA 2SA1577 T106 Q	T	107.7/44.3
Q27	1520000460	S.TRA 2SB1132 T100 R	B	123.5/21.1
Q28	1590001190	S.TRA XP6501-(TX),AB	B	118.7/22.2
Q29	1590001050	S.TRA DTC114TUA T106	B	126.4/43.3
Q30	1590000430	S.TRA DTC144EUA T106	T	107.7/39.4
Q31	1590001451	S.FET 2SJ144-GR (TE85R,F)	B	114.3/13.1
Q33	1590000430	S.TRA DTC144EUA T106	T	113.6/26.6
Q34	1530002851	S.TRA 2SC4116-BL(TE85R,F)	B	67.6/25.1
Q35	1590000990	S.TRA DTC363EK T146	B	128.9/17.8
Q36	1590000430	S.TRA DTC144EUA T106	B	118.7/18.3
Q37	1590000430	S.TRA DTC144EUA T106	T	112.5/15.5
Q39	1590001650	S.TRA XP4601(TX)	T	25.2/19.5
Q40	1590001330	S.TRA DTA114EUA T106	T	46.6/33
Q43	1560001360	S.FET 2SK3019 TL	T	52.1/27.7
Q44	1590000680	S.TRA DTC114EUA T106	T	36.4/15.2
D1	1790001211	S.DIO 1SS375-TL-E	B	21.8/54.2
D3	1710001061	DIO L407CDB		
D4	1750000721	S.VAR HVC375BTRF-E	B	33.3/38.3
D5	1750001360	S.DIO L709CER (9401) [USA-01]	T	24.7/53.6
	1750001360	S.DIO L709CER (9401) [EXP-02]		
	1750001360	S.DIO L709CER (9401) [CHN-01]		
D6	1750000581	S.DIO 1SV307(TPH3,F)	B	24.8/46.8
D8	1750000721	S.VAR HVC375BTRF-E	B	30.5/38.3
D9	1750000711	S.VAR HVC350BTRF-E	B	53.8/39.9
D10	1750000711	S.VAR HVC350BTRF-E	B	56.6/39.9
D11	1790001211	S.DIO 1SS375-TL-E	B	8.2/49.9
D12	1790001211	S.DIO 1SS375-TL-E	B	42/58.2
D14	1790001261	S.DIO MA2S077G0L	B	83.4/41.8
D15	1790001261	S.DIO MA2S077G0L	B	83.2/39.3
D16	1750000771	S.VAR HVC376BTRF-E	B	107.2/22.1
D18	1750001570	S.VAR HVL355CMKRF-E	B	104.1/25.8
D22	1790000700	DIO DSA3A1		
D23	1750000370	S.DIO DA221 TL	B	124/43.3
D26	1790001251	S.DIO MA2S1110GL	B	116.7/17.2
D28	1790001241	S.DIO MA2S7280GL	T	63.8/52.8
D29	1790001251	S.DIO MA2S1110GL	B	119.2/20.2
D31	1750000771	S.VAR HVC376BTRF-E	B	105.6/23.2
D33	1750000771	S.VAR HVC376BTRF-E	B	91.4/22.2
D34	1750000771	S.VAR HVC376BTRF-E	B	93.9/22.2
D37	1790001251	S.DIO MA2S1110GL	T	79.9/33.4
D42	1160000140	S.DIO DAP222 TL	B	37.1/7.2
D43	1160000140	S.DIO DAP222 TL	B	35/7.2
D44	1790001251	S.DIO MA2S1110GL	B	48.9/5.4
D45	1790001251	S.DIO MA2S1110GL	B	51.5/5.4
D47	1750000581	S.DIO 1SV307(TPH3,F) [EUR-01]	T	21.4/52
	1750000581	S.DIO 1SV307(TPH3,F) [EXP-01]		
D48	1750000581	S.DIO 1SV307(TPH3,F) [EUR-01]	T	21.4/53.8
	1750000581	S.DIO 1SV307(TPH3,F) [EXP-01]		
D52	1750000721	S.VAR HVC375BTRF-E	B	99.7/22.1
D53	1750000721	S.VAR HVC375BTRF-E	B	103/28.1
D54	1790001261	S.DIO MA2S077G0L	B	90.6/33.6
D55	1790001261	S.DIO MA2S077G0L	B	91.8/33.6
D56	1750001070	S.DIO DAN235ETL	T	51.5/33.5
D57	1750001070	S.DIO DAN235ETL	T	48.2/30.4

[MAIN-A UNIT]

REF NO.	PARTS NO.	DESCRIPTION	M.	H/V LOCATION
D58	1750000370	S.DIO DA221 TL	B	113.7/10.8
D59	1750000370	S.DIO DA221 TL	T	113/7.1
D60	1750000370	S.DIO DA221 TL	B	113/8.4
D61	1750000370	S.DIO DA221 TL	T	113/9.4
D62	1750000370	S.DIO DA221 TL	T	33.7/37.1
D63	1790001241	S.DIO MA2S7280GL	T	31.8/39.7
F11	2030000150	S.MON DSF753SB 46.350 MHz(FL-335)	T	66.6/34.9
F12	2020002410	CER LTM450FW <JJE>		
F13	2040001440	S.LC NFE31PT152Z1E9L (NFM60R20T152)	B	97.7/58.1
F14	2040001440	S.LC NFE31PT152Z1E9L (NFM60R20T152)	B	97.7/61.6
F15	2040001440	S.LC NFE31PT152Z1E9L (NFM60R20T152) [USA-01]	B	97.7/64.9
	2040001440	S.LC NFE31PT152Z1E9L (NFM60R20T152) [EXP-02]		
	2040001440	S.LC NFE31PT152Z1E9L (NFM60R20T152) [CHN-01]		
F16	2020002460	CER LTM450GW <JJE>		
X1	6070000300	S.DIS JTBM450CX24 <JJE>	B	52.4/24.5
X2	6050012050	S.XTA CR-794 TTS14VSB-A6 15.3 MHz	B	80.8/23.8
L1	6200010050	S.COI AS080547-47N	B	9.4/62.7
L2	6200010050	S.COI AS080547-47N	B	12.7/56.4
L3	6200010050	S.COI AS080547-47N	B	25.4/58.6
L4	6200010050	S.COI AS080547-47N	T	30/51.1
L5	6200010420	S.COI FHW1210HC 1R0JGT <JJE>	T	29.7/57.9
L6	6200010720	S.COI C2520C-56NG-A	B	26.7/49.7
L7	6200011410	S.COI C2520C-82NG-A	B	28.2/39.9
L8	6200011410	S.COI C2520C-82NG-A	B	35.6/38.3
L9	6200010720	S.COI C2520C-56NG-A	B	49/39.8
L10	6200004660	S.COI MLF1608A 1R8K-T	T	78.4/13.3
L11	6200010720	S.COI C2520C-56NG-A	B	58.9/40.5
L13	6200010090	S.COI ELJND R82JF	B	68.1/40.6
L16	6200010050	S.COI AS080547-47N	B	38.7/64.5
L21	6200011021	S.COI ELJRF 82NJFB	B	92.7/35.3
L22	6200011011	S.COI ELJRF 68NJFB	B	99/34.3
L23	6200007001	S.COI ELJRE 82NGFA	B	85.9/59.3
L25	6200013020	S.COI 0.25-1.9-7TL 61N <COMO>	B	107/28.7
L26	6200009910	S.COI C6342A-88NG-A	B	93.6/26.2
L27	6200002001	S.COI NLV25T-3R3J	B	104/20
L28	6200007850	S.COI ELJNC R82K-F	B	94.3/19.7
L31	6200010000	S.COI C2012C-56NG-A	B	24.8/44.8
L32	6200007901	S.COI ELJRF 22NJFB	B	82.8/32.8
L33	6200004480	S.COI MLF1608D R82K-T	B	62.9/23.3
L35	6200003540	S.COI MLF1608D R22K-T	B	65.3/23.3
L36	6200006981	S.COI ELJRE R10GFA	B	73.5/38.4
L37	6200005550	S.COI ELJFC 100K-F	B	96.8/19.7
L38	6200013020	S.COI 0.25-1.9-7TL 61N <COMO>	B	107/20
L39	6200012760	S.COI 0.35-1.6-7TL 37.5N <COMO>	B	91.5/19.7
L41	6200007911	S.COI ELJRF 18NJFB	B	95.8/31
L43	6200005741	S.COI ELJRE 47NGFA	B	88.6/59.3
L44	6200007901	S.COI ELJRF 22NJFB	B	84.5/32.8
L45	6200007911	S.COI ELJRF 18NJFB	B	85.4/31.5
L46	6200002001	S.COI NLV25T-3R3J	T	97.4/19.5
L47	6200002861	S.COI NLV25T-4R7J	T	102.8/24.4
L53	6200003640	S.COI MLF1608E 100K-T	B	106.8/24.6
L54	6200007120	S.COI ELJND 1R0J	T	100.1/31.1
R1	7030000620	S.RES MCR10EZJH 100 K (104)	B	17.4/64.6
R4	7030003560	S.RES ERJ3GEYJ 103 V (10K)	B	18.8/54.2
R5	7030005060	S.RES ERJ2GEJ 333 X (33K) [EUR-01]	B	24.1/53.8
	7030005060	S.RES ERJ2GEJ 333 X (33K) [EXP-01]		
	7030005070	S.RES ERJ2GEJ 683 X (68K) [USA-01]		
	7030005070	S.RES ERJ2GEJ 683 X (68K) [EXP-02]		
	7030005070	S.RES ERJ2GEJ 683 X (68K) [CHN-01]		
R6	7030005060	S.RES ERJ2GEJ 333 X (33K) [EUR-01]	B	11.2/49.6
	7030005060	S.RES ERJ2GEJ 333 X (33K) [EXP-01]		
	7030005070	S.RES ERJ2GEJ 683 X (68K) [USA-01]		
	7030005070	S.RES ERJ2GEJ 683 X (68K) [EXP-02]		
	7030005070	S.RES ERJ2GEJ 683 X (68K) [CHN-01]		
R7	7030003560	S.RES ERJ3GEYJ 103 V (10K)	B	8.2/53.2
R8	7030006070	S.RES ERJ12YJ101U (100)	B	45.7/51.9
R9	7030003560	S.RES ERJ3GEYJ 103 V (10K)	B	38.6/58.6
R10	7030005060	S.RES ERJ2GEJ 333 X (33K) [EUR-01]	B	44.8/57.9
	7030005060	S.RES ERJ2GEJ 333 X (33K) [EXP-01]		
	7030005070	S.RES ERJ2GEJ 683 X (68K) [USA-01]		
	7030005070	S.RES ERJ2GEJ 683 X (68K) [EXP-02]		
	7030005070	S.RES ERJ2GEJ 683 X (68K) [CHN-01]		
R11	7030005040	S.RES ERJ2GEJ 472 X (4.7K)	B	31.9/38.4
R12	7030004980	S.RES ERJ2GEJ 101 X (100)	B	39.2/39.5
R13	7030005040	S.RES ERJ2GEJ 472 X (4.7K)	B	31.9/39.7
R14	7030005050	S.RES ERJ2GEJ 103 X (10K)	B	31.9/35.5
R15	7030005070	S.RES ERJ2GEJ 274 X (270K)	B	39.2/38.6
R16	7030008280	S.RES ERJ2GEJ 271 X (270)	B	39.5/40.7
R17	7030004980	S.RES ERJ2GEJ 101 X (100)	B	51.5/40.2
R19	7030005090	S.RES ERJ2GEJ 104 X (100K)	B	39.2/36.8
R20	7030009200	S.RES ERJ2GEJ 390 X (39)	B	52.7/38.7
R21	7030005050	S.RES ERJ2GEJ 103 X (10K)	B	55.2/40.2
R22	7030005050	S.RES ERJ2GEJ 103 X (10K)	B	63.7/36.7
R23	7030005050	S.RES ERJ2GEJ 103 X (10K)	B	55.2/41.3
R26	7030005000	S.RES ERJ2GEJ 471 X (470)	B	79/40.6

M.=Mounted side (T: Mounted on the Top side, B: Mounted on the Bottom side)  
S.=Surface mount

[MAIN-A UNIT]

REF NO.	PARTS NO.	DESCRIPTION	M.	H/V LOCATION
R27	7030005000	S.RES ERJ2GEJ 471 X (470)	B	77.9/40.6
R28	7030010430	S.RES ERJ2GEJ 120 X (12)	B	78.5/39.3
R29	7030005070	S.RES ERJ2GEJ 820 X (82)	B	73.5/40.6
R30	7030005000	S.RES ERJ2GEJ 471 X (470)	B	70.5/40.6
R31	7030004980	S.RES ERJ2GEJ 101 X (100)	B	65.8/40.6
R32	7030010040	S.RES ERJ2GEJ-JPW	T	68.3/40.2
R33	7030009160	S.RES ERJ2GEJ 181 X (180)	B	65.3/29.5
R34	7030005090	S.RES ERJ2GEJ 104 X (100K)	T	66.3/27.8
R35	7030004980	S.RES ERJ2GEJ 101 X (100)	T	67.3/27.8
R36	7030008410	S.RES ERJ2GEJ 392 X (3.9K)	B	57.1/25.7
R37	7030009140	S.RES ERJ2GEJ 272 X (2.7K)	T	56.4/19
R38	7030005090	S.RES ERJ2GEJ 104 X (100K)	T	59.3/19.2
R39	7030004970	S.RES ERJ2GEJ 470 X (47)	B	58.2/22.2
R40	7030005030	S.RES ERJ2GEJ 152 X (1.5K)	B	60.4/24.8
R41	7030010040	S.RES ERJ2GEJ-JPW	T	60.2/17.8
R42	7030007340	S.RES ERJ2GEJ 153 X (15K)	T	50.4/26.1
R43	7030005000	S.RES ERJ2GEJ 471 X (470)	T	55.2/19.6
R44	7030005110	S.RES ERJ2GEJ 224 X (220K)	T	53.9/26.1
R45	7030005310	S.RES ERJ2GEJ 124 X (120K)	T	52.1/26.1
R46	7030007290	S.RES ERJ2GEJ 222 X (2.2K)	T	53.9/24.3
R48	7030008300	S.RES ERJ2GEJ 184 X (180K) [USA-01]	T	56.8/53.2
	7030008300	S.RES ERJ2GEJ 184 X (180K) [EXP-02]		
	7030008300	S.RES ERJ2GEJ 184 X (180K) [CHN-01]		
R49	7520000230	S.POS PRF18BD471QB1RB [USA-01]	T	42/53.2
	7520000230	S.POS PRF18BD471QB1RB [EXP-02]		
	7520000230	S.POS PRF18BD471QB1RB [CHN-01]		
R50	7030005000	S.RES ERJ2GEJ 471 X (470)	B	80.7/38
R51	7030008310	S.RES ERJ2GEJ 564 X (560K)	T	61.5/52.1
R52	7030007340	S.RES ERJ2GEJ 153 X (15K)	T	58.7/52.1
R53	7030004990	S.RES ERJ2GEJ 221 X (220)	T	57.8/53.2
R54	7030005050	S.RES ERJ2GEJ 103 X (10K)	B	58.8/55.7
R55	7030005040	S.RES ERJ2GEJ 472 X (4.7K)	T	64.3/51.1
R56	7030005100	S.RES ERJ2GEJ 154 X (150K)	T	63.8/54.9
R57	7030005050	S.RES ERJ2GEJ 103 X (10K)	B	58.8/54.8
R58	7030005000	S.RES ERJ2GEJ 471 X (470)	T	64.7/54.9
R59	7030008290	S.RES ERJ2GEJ 183 X (18K)	T	59.7/52.1
R67	7030004980	S.RES ERJ2GEJ 101 X (100)	B	83.3/49.1
R68	7030005050	S.RES ERJ2GEJ 103 X (10K)	B	81.7/49.1
R69	7030005040	S.RES ERJ2GEJ 472 X (4.7K)	B	84/38
R70	7030004980	S.RES ERJ2GEJ 101 X (100)	B	94/36.2
R71	7030004980	S.RES ERJ2GEJ 101 X (100)	B	95.9/34.4
R73	7030004980	S.RES ERJ2GEJ 101 X (100)	B	97.7/35.3
R74	7030005310	S.RES ERJ2GEJ 124 X (120K)	B	100.7/34.3
R75	7030005110	S.RES ERJ2GEJ 224 X (220K)	B	97.7/32.6
R76	7030004980	S.RES ERJ2GEJ 101 X (100)	B	97.7/33.5
R77	7030007290	S.RES ERJ2GEJ 222 X (2.2K)	T	105.6/35.6
R78	7030005120	S.RES ERJ2GEJ 102 X (1K)	B	103.1/32.9
R79	7030008340	S.RES RR0510P-182-D (1.8K)	B	98.8/25.3
R80	7030005800	S.RES RR0510P-102-D (1K)	B	99.7/28.1
R83	7030008340	S.RES RR0510P-182-D (1.8K)	B	106.1/30.8
R84	7030011000	S.RES RR0510P-392-D (3.9K)	B	103/30.2
R85	7030011000	S.RES RR0510P-392-D (3.9K)	B	97.9/28.1
R86	7030005310	S.RES ERJ2GEJ 124 X (120K)	B	105.1/25.9
R89	7030005050	S.RES ERJ2GEJ 103 X (10K)	T	80/25.1
R90	7030005240	S.RES ERJ2GEJ 473 X (47K)	T	95.4/12.9
R91	7030005220	S.RES ERJ2GEJ 223 X (22K)	T	93.8/12
R92	7030005090	S.RES ERJ2GEJ 104 X (100K)	T	93.8/12.9
R93	7030005120	S.RES ERJ2GEJ 102 X (1K)	T	78.8/33.4
R95	7030005120	S.RES ERJ2GEJ 102 X (1K)	T	84.2/27.4
R96	7030007570	S.RES ERJ2GEJ 122 X (1.2K)	T	82.6/27.4
R97	7030004990	S.RES ERJ2GEJ 221 X (220)	T	82.3/28.7
R98	7030007290	S.RES ERJ2GEJ 222 X (2.2K)	T	109.5/33.8
R100	7030005050	S.RES ERJ2GEJ 103 X (10K)	T	78.1/22.2
R101	7030005120	S.RES ERJ2GEJ 102 X (1K)	T	79/22.2
R103	7030005100	S.RES ERJ2GEJ 154 X (150K)	T	77.9/33.4
R104	7030005080	S.RES ERJ2GEJ 823 X (82K)	B	81/21.2
R105	7030008300	S.RES ERJ2GEJ 184 X (180K)	B	84.7/21.2
R106	7030005080	S.RES ERJ2GEJ 823 X (82K)	B	82.7/20.3
R110	7030005700	S.RES ERJ2GEJ 274 X (270K)	B	82.7/21.2
R111	7030007300	S.RES ERJ2GEJ 332 X (3.3K)	T	30.5/29.6
R112	7030005240	S.RES ERJ2GEJ 473 X (47K)	T	29.6/29.6
R113	7030007290	S.RES ERJ2GEJ 222 X (2.2K)	T	31.4/29.6
R114	7030008010	S.RES ERJ2GEJ 123 X (12K)	T	19.2/21.6
R115	7030008410	S.RES ERJ2GEJ 392 X (3.9K)	B	13.4/23.3
R116	7030008010	S.RES ERJ2GEJ 123 X (12K)	B	15.1/22.4
R117	7030008300	S.RES ERJ2GEJ 184 X (180K)	B	20.7/15.3
R118	7030008010	S.RES ERJ2GEJ 123 X (12K)	T	19.2/20.7
R119	7030009290	S.RES ERJ2GEJ 562 X (5.6K)	T	18.8/23.5
R120	7030005050	S.RES ERJ2GEJ 103 X (10K)	B	16.3/22.8
R121	7030005240	S.RES ERJ2GEJ 473 X (47K)	B	15.1/23.3
R122	7030005210	S.RES ERJ2GEJ 822 X (8.2K)	T	28.1/24.3
R123	7030005090	S.RES ERJ2GEJ 104 X (100K)	B	27.6/22.9
R124	7030005040	S.RES ERJ2GEJ 472 X (4.7K)	B	28.5/18
R125	7030005090	S.RES ERJ2GEJ 104 X (100K)	B	27.6/21.3
R126	7030005000	S.RES ERJ2GEJ 471 X (470)	B	27.6/19.6
R127	7030005230	S.RES ERJ2GEJ 334 X (330K)	B	25.8/19.6
R128	7030005050	S.RES ERJ2GEJ 103 X (10K)	B	26.7/18
R129	7030004980	S.RES ERJ2GEJ 101 X (100)	T	30.9/16.2
R130	7030005220	S.RES ERJ2GEJ 223 X (22K)	T	29/24.3
R133	7030005090	S.RES ERJ2GEJ 104 X (100K)	T	30.8/24.3
R134	7030005060	S.RES ERJ2GEJ 333 X (33K)	T	14.6/19.9
R135	7030005700	S.RES ERJ2GEJ 274 X (270K)	T	29.9/26
R137	7030005070	S.RES ERJ2GEJ 683 X (68K)	T	11.8/16.1
R138	7030005090	S.RES ERJ2GEJ 104 X (100K)	B	33.3/12
R139	7030005090	S.RES ERJ2GEJ 104 X (100K)	B	33.3/11.1
R142	7410001130	S.ARR EXB28V102JX	T	69.7/14.8
R143	7030005120	S.RES ERJ2GEJ 102 X (1K)	T	64.8/16.2
R144	7030005120	S.RES ERJ2GEJ 102 X (1K)	T	74.3/14.1
R145	7030005120	S.RES ERJ2GEJ 102 X (1K)	T	72.9/15.3
R146	7030005120	S.RES ERJ2GEJ 102 X (1K)	T	70.1/6.3
R147	7410001130	S.ARR EXB28V102JX	T	56.8/6.7
R148	7410001130	S.ARR EXB28V102JX	T	61.7/6.1
R149	7410001130	S.ARR EXB28V102JX	T	65.8/6.1
R150	7410001130	S.ARR EXB28V102JX	T	75.3/6

[MAIN-A UNIT]

REF NO.	PARTS NO.	DESCRIPTION	M.	H/V LOCATION
R156	7030005040	S.RES ERJ2GEJ 472 X (4.7K)	B	116.6/21.9
R159	7030005050	S.RES ERJ2GEJ 103 X (10K)	B	117/17.4
R183	7030008300	S.RES ERJ2GEJ 184 X (180K)	T	29.9/24.3
R184	7030005060	S.RES ERJ2GEJ 333 X (33K)	B	15.1/19.7
R185	7030005310	S.RES ERJ2GEJ 124 X (120K)	B	15.1/18.8
R186	7030005090	S.RES ERJ2GEJ 104 X (100K)	T	17.1/19.9
R187	7030005050	S.RES ERJ2GEJ 103 X (10K)	T	16.8/17.9
R188	7030008370	S.RES ERJ2GEJ 561 X (560)	B	16.8/17
R191	7030005110	S.RES ERJ2GEJ 224 X (220K)	B	28.8/7.3
R192	7030005110	S.RES ERJ2GEJ 224 X (220K)	B	29.8/7.3
R193	7030005170	S.RES ERJ2GEJ 474 X (470K)	B	34.2/9.3
R194	7030007290	S.RES ERJ2GEJ 222 X (2.2K)	B	27.8/5.7
R195	7030005120	S.RES ERJ2GEJ 102 X (1K)	B	123.7/17.8
R197	7030005050	S.RES ERJ2GEJ 103 X (10K)	B	125.5/16
R198	7030005050	S.RES ERJ2GEJ 103 X (10K)	T	128.6/24.1
R199	7030005050	S.RES ERJ2GEJ 103 X (10K)	T	133.3/49.2
R200	7030005240	S.RES ERJ2GEJ 473 X (47K)	T	114.7/49
R201	7030005040	S.RES ERJ2GEJ 472 X (4.7K)	T	110.5/46.6
R202	7030000480	S.RES MCR10EZJH 6.8K (682)	B	129.4/48.8
R203	7030000480	S.RES MCR10EZJH 6.8K (682)	B	129.4/47
R204	7030005040	S.RES ERJ2GEJ 472 X (4.7K)	T	107.7/41.4
R205	7030005050	S.RES ERJ2GEJ 103 X (10K)	T	107.7/42.3
R209	7510001730	S.THE ERTJOEP 473J	T	77.4/15.3
R210	7030008270	S.RES RR0510P-104-D (100K)	T	75.4/15.3
R211	7030004970	S.RES ERJ2GEJ 470 X (47)	T	82.6/30.5
R212	7030004980	S.RES ERJ2GEJ 101 X (100)	T	83.1/61.1
R213	7030005050	S.RES ERJ2GEJ 103 X (10K)	T	84.1/61.1
R215	7030005000	S.RES ERJ2GEJ 471 X (470)	B	37.4/30
R218	7030005220	S.RES ERJ2GEJ 223 X (22K)	T	60.9/19.2
R220	7030005050	S.RES ERJ2GEJ 103 X (10K)	B	79.4/19.4
R221	7030010040	S.RES ERJ2GEJ-JPW	B	84.7/22.1
R222	7030005240	S.RES ERJ2GEJ 473 X (47K)	B	81/20.3
R223	7030005120	S.RES ERJ2GEJ 102 X (1K)	B	116.7/10.8
R224	7030004970	S.RES ERJ2GEJ 470 X (47)	B	114.5/15.1
R225	7030010040	S.RES ERJ2GEJ-JPW	B	111.6/13.1
R226	7030005090	S.RES ERJ2GEJ 104 X (100K)	B	116.7/13.1
R227	7030005160	S.RES ERJ2GEJ 105 X (1M)	T	111.2/12.9
R228	7030005090	S.RES ERJ2GEJ 104 X (100K)	B	115.4/15.1
R229	7030005160	S.RES ERJ2GEJ 105 X (1M)	B	116.7/14
R230	7030005090	S.RES ERJ2GEJ 104 X (100K)	T	95.4/12
R231	7030005120	S.RES ERJ2GEJ 102 X (1K)	B	37.9/21.1
R232	7030005170	S.RES ERJ2GEJ 474 X (470K)	B	35.4/8.9
R234	7030005050	S.RES ERJ2GEJ 103 X (10K)	B	94/35.3
R235	7030005050	S.RES ERJ2GEJ 103 X (10K)	B	81.6/38
R236	7030007570	S.RES ERJ2GEJ 122 X (1.2K)	B	67.1/21.5
R237	7030007060	S.RES ERJ2GEJ 684X (680K)	B	67.1/23.3
R238	7030005090	S.RES ERJ2GEJ 104 X (100K)	T	113.7/28.4
R240	7030005090	S.RES ERJ2GEJ 104 X (100K)	B	25.8/22.9
R241	7030005090	S.RES ERJ2GEJ 104 X (100K)	B	26.7/24.6
R242	7030007350	S.RES ERJ2GEJ 393 X (39K)	B	25.8/24.6
R243	7030005080	S.RES ERJ2GEJ 823 X (82K)	B	24.9/22.9
R244	7030006610	S.RES ERJ2GEJ 394 X (390K)	B	24/24.6
R245	7030008300	S.RES ERJ2GEJ 184 X (180K)	B	23.1/24.6
R247	7030005220	S.RES ERJ2GEJ 223 X (22K)	T	29.7/17.3
R248	7030005220	S.RES ERJ2GEJ 223 X (22K)	T	29.1/19.5
R249	7030005220	S.RES ERJ2GEJ 223 X (22K)	T	27.5/19.5
R250	7030005050	S.RES ERJ2GEJ 103 X (10K)	T	26.2/21.6
R251	7030007290	S.RES ERJ2GEJ 222 X (2.2K)	T	24.9/21.6
R252	7030005090	S.RES ERJ2GEJ 104 X (100K)	T	25.2/17.7
R253	7030005240	S.RES ERJ2GEJ 473 X (47K)	T	22.9/19.5
R254	7030008370	S.RES ERJ2GEJ 561 X (560)	T	22.9/20.4
R255	7030005050	S.RES ERJ2GEJ 103 X (10K)	T	27.5/20.4
R256	7030005050	S.RES ERJ2GEJ 103 X (10K)	T	29.1/20.4
R261	7030005160	S.RES ERJ2GEJ 105 X (1M)	T	23.8/13.4
R262	7030005160	S.RES ERJ2GEJ 105 X (1M)	T	24.7/13.4
R263	7030005160	S.RES ERJ2GEJ 105 X (1M)	T	25.6/13.4
R269	7030005090	S.RES ERJ2GEJ 104 X (100K)	B	25.7/8.4
R270	7030005090	S.RES ERJ2GEJ 104 X (100K)	B	26.8/8.4
R271	7030004980	S.RES ERJ2GEJ 101 X (100)	T	16.8/12.8
R285	7030004980	S.RES ERJ2GEJ 101 X (100)	T	14.6/18.1
R287	7030005050	S.RES ERJ2GEJ 103 X (10K)	B	117.5/20.2
R290	7030005010	S.RES ERJ2GEJ 681 X (680)	T	66.3/26
R291	7030005090	S.RES ERJ2GEJ 104 X (100K)	T	93.8/13.8
R297	7030005651	S.RES ERA3YKD 304V (300K)	B	72.5/9.4
R298	7030008270	S.RES RR0510P-104-D (100K)	B	73.9/10.4
R299	7030008300	S.RES ERJ2GEJ 184 X (180K)	B	74.6/38.5
R300	7030005720	S.RES ERJ2GEJ 563 X (56K)	B	76.8/40.6
R301	7030005100	S.RES ERJ2GEJ 154 X (150K)	B	66.7/40.6
R302	7030005720	S.RES ERJ2GEJ 563 X (56K)	B	



[MAIN-A UNIT]

REF NO.	PARTS NO.	DESCRIPTION	M.	H/V LOCATION
R340	7030005050	S.RES ERJ2GEJ 103 X (10K)	B	76.9/23.9
R341	7030007340	S.RES ERJ2GEJ 153 X (15K)	B	92.7/31.3
R342	7030007340	S.RES ERJ2GEJ 153 X (15K)	B	91/31.3
R345	7030005000	S.RES ERJ2GEJ 471 X (470)	B	76.9/32.3
R348	7030005170	S.RES ERJ2GEJ 474 X (470K)	T	95.4/15
R349	7030005090	S.RES ERJ2GEJ 104 X (100K)	T	102/18.7
R350	7030005600	S.RES ERJ2GEJ 273 X (27K)	T	51.2/35
R351	7030005600	S.RES ERJ2GEJ 273 X (27K)	T	49.6/28.6
R352	7030007300	S.RES ERJ2GEJ 332 X (3.3K)	T	49.5/33.9
R353	7030005210	S.RES ERJ2GEJ 822 X (8.2K)	T	49.5/33
R354	7030005210	S.RES ERJ2GEJ 822 X (8.2K)	T	46.6/30.4
R355	7030010040	S.RES ERJ2GEJ-JPW	T	124.9/24.8
R356	7030005120	S.RES ERJ2GEJ 102 X (1K)	B	115.5/8.4
R357	7030005120	S.RES ERJ2GEJ 102 X (1K)	T	114.9/7.1
R358	7030005120	S.RES ERJ2GEJ 102 X (1K)	T	113.2/16.9
R359	7030005090	S.RES ERJ2GEJ 104 X (100K)	T	113/10.9
R360	7030005090	S.RES ERJ2GEJ 104 X (100K)	B	114.6/8.4
R361	7030005090	S.RES ERJ2GEJ 104 X (100K)	T	111.5/7.1
R362	7030005090	S.RES ERJ2GEJ 104 X (100K)	B	55.7/6.3
R363	7030005050	S.RES ERJ2GEJ 103 X (10K)	T	76.1/22.2
R368	7030010040	S.RES ERJ2GEJ-JPW	B	33.3/22.8
R370	7030010040	S.RES ERJ2GEJ-JPW	B	13.4/18.8
R371	7030007350	S.RES ERJ2GEJ 393 X (39K)	B	36.6/21.1
R372	7030005240	S.RES ERJ2GEJ 473 X (47K)	T	27/13.4
R373	7030005240	S.RES ERJ2GEJ 473 X (47K)	T	28.3/12.4
R374	7030005230	S.RES ERJ2GEJ 334 X (330K)	T	30.5/12.4
R375	7030005230	S.RES ERJ2GEJ 334 X (330K)	B	29.8/14.3
R377	7030005230	S.RES ERJ2GEJ 334 X (330K)	T	39.4/19
R378	7030005090	S.RES ERJ2GEJ 104 X (100K)	T	121.6/37.6
R381	7030010040	S.RES ERJ2GEJ-JPW	B	57.8/10.2
R382	7030010040	S.RES ERJ2GEJ-JPW	T	123.9/67.6
R383	7030010040	S.RES ERJ2GEJ-JPW	B	133.7/67.7
R384	7030007320	S.RES ERJ2GEJ 225 X (2.2M)	B	26.7/19.6
R385	7030004970	S.RES ERJ2GEJ 470 X (47)	B	83.3/52.8
R386	7030007340	S.RES ERJ2GEJ 153 X (15K)	B	85/53.7
R387	7030005040	S.RES ERJ2GEJ 472 X (4.7K)	B	86.6/58.2
R388	7030007260	S.RES ERJ2GEJ 330 X (33)	B	85/55.5
R390	7030005060	S.RES ERJ2GEJ 333 X (33K)	B	54.7/37.8
R391	7030005700	S.RES ERJ2GEJ 274 X (270K)	T	31.7/24.3
R392	7030008290	S.RES ERJ2GEJ 183 X (18K)	T	121.6/38.5
C1	4030011170	S.CER GRM31M2C2H180JV01L (GRM42-6 CH)	B	8.4/66.6
C2	4030011180	S.CER GRM31M2C2H220JV01L (GRM42-6 CH)	B	7.4/58.6
C3	4030009500	S.CER C1608 CH 1H 0R5B-T	B	18.8/55.5
C4	4030009570	S.CER C1608 CH 1H 0R3B-T	B	37.3/58.6
C5	4030009500	S.CER C1608 CH 1H 0R5B-T	B	8.2/54.5
C6	4030011180	S.CER GRM31M2C2H220JV01L (GRM42-6 CH)	B	7.4/56.3
C7	4030011180	S.CER GRM31M2C2H220JV01L (GRM42-6 CH)	B	18/58.7
C8	4030011180	S.CER GRM31M2C2H220JV01L (GRM42-6 CH)	B	26.4/63.8
C9	4030011170	S.CER GRM31M2C2H180JV01L (GRM42-6 CH)	T	29.4/55
C10	4030017460	S.CER ECJ0EB1E102K	B	23.8/55
C11	4030017460	S.CER ECJ0EB1E102K	T	10/49.2
C12	4030017460	S.CER ECJ0EB1E102K	T	39.4/55
C13	4030017420	S.CER ECJ0EC1H470J	B	49.5/51.4
C14	4030017200	S.CER GRM31BR32J102KY01L (GHM1030 R)	B	35/57
C15	4030018070	S.CER ECJ0EC1H300J	B	24.3/51.2
C17	4030017600	S.CER ECJ0EC1H080C	B	24.3/48.3
C18	4030017580	S.CER ECJ0EC1H060C	B	22.3/44.8
C19	4030017460	S.CER ECJ0EB1E102K	B	27/46.2
C20	4030017400	S.CER ECJ0EC1H220J	B	30.5/40.5
C22	4030017550	S.CER ECJ0EC1H1R5B	B	31.9/37.5
C23	4030017350	S.CER ECJ0EC1H020B	T	70/33.4
C25	4030017630	S.CER ECJ0EC1H120J	B	25.1/40.2
C26	4030017400	S.CER ECJ0EC1H220J	B	33.3/40.5
C27	4030017460	S.CER ECJ0EB1E102K	B	31.9/36.5
C28	4030017460	S.CER ECJ0EB1E102K	B	33.6/35.5
C29	4030017340	S.CER ECJ0EC1H010B	B	37.7/38.1
C30	4030017620	S.CER ECJ0EC1H100C	B	39.2/37.7
C31	4030016930	S.CER ECJ0EB1A104K	T	37.3/36.2
C32	4030017460	S.CER ECJ0EB1E102K	B	41.3/40.7
C33	4030016930	S.CER ECJ0EB1A104K	B	38.6/40.7
C34	4030017460	S.CER ECJ0EB1E102K	B	37.7/40.7
C35	4030018860	S.CER ECJ0EBOJ105K	B	48.5/42.8
C36	4030017460	S.CER ECJ0EB1E102K	B	51.5/41.3
C37	4030017460	S.CER ECJ0EB1E102K	B	49.5/42.8
C38	4030017460	S.CER ECJ0EB1E102K	B	39.2/35.9
C39	4030017460	S.CER ECJ0EB1E102K	B	53.8/42
C40	4030017570	S.CER ECJ0EC1H040B	B	55.2/39.1
C41	4030017390	S.CER ECJ0EC1H180J	B	66.3/39.1
C42	4030017460	S.CER ECJ0EB1E102K	B	63.7/35
C43	4030017460	S.CER ECJ0EB1E102K	B	55.6/37.8
C44	4030017530	S.CER ECJ0EC1H0R5B	B	61.1/40.5
C45	4030017460	S.CER ECJ0EB1E102K	B	56.6/42
C46	4030017350	S.CER ECJ0EC1H020B	B	41/36.8
C48	4030016930	S.CER ECJ0EB1A104K	B	71.5/40.6
C49	4030017600	S.CER ECJ0EC1H080C	B	76.3/39.3
C50	4030017460	S.CER ECJ0EB1E102K	B	72.5/40.6
C51	4030017460	S.CER ECJ0EB1E102K	T	69.3/40.2
C52	4030017620	S.CER ECJ0EC1H100C	B	69.5/40.6
C53	4030016930	S.CER ECJ0EB1A104K	B	70.5/42.3
C54	4030017460	S.CER ECJ0EB1E102K	B	69.5/42.3
C55	4030017570	S.CER ECJ0EC1H040B	T	67.3/40.2
C56	4030017400	S.CER ECJ0EC1H220J	T	70/36.4
C57	4030017460	S.CER ECJ0EB1E102K	B	65.8/36.7
C58	4030017460	S.CER ECJ0EB1E102K	T	65.3/27.8
C59	4030017460	S.CER ECJ0EB1E102K	T	67.3/29.5

[MAIN-A UNIT]

REF NO.	PARTS NO.	DESCRIPTION	M.	H/V LOCATION
C60	4030016790	S.CER ECJ0EB1C103K	T	67.3/23
C61	4030017430	S.CER ECJ0EC1H101J	T	61.6/26.1
C62	4030017680	S.CER ECJ0EC1H820J	T	56.4/20.2
C63	4030017420	S.CER ECJ0EC1H470J	T	60.2/16.2
C64	4030017460	S.CER ECJ0EB1E102K	T	56.4/17.4
C65	4030018860	S.CER ECJ0EBOJ105K	T	70.4/17.5
C66	4030017460	S.CER ECJ0EB1E102K	T	51.6/16.8
C67	4030017460	S.CER ECJ0EB1E102K	B	60.4/23.2
C68	4030017430	S.CER ECJ0EC1H101J	T	52.1/25.2
C69	4030017690	S.CER ECJ0EC1H121J	T	53.9/25.2
C70	4030017690	S.CER ECJ0EC1H121J	T	53.9/27
C71	4030016930	S.CER ECJ0EB1A104K	T	56.9/29.4
C72	4030017460	S.CER ECJ0EB1E102K [USA-01]	T	56.8/50.7
	4030017460	S.CER ECJ0EB1E102K [EXP-02]	T	
	4030017460	S.CER ECJ0EB1E102K [CHN-01]	T	
C73	4030018860	S.CER ECJ0EBOJ105K	T	63.8/49.8
C74	4030017460	S.CER ECJ0EB1E102K	B	24.8/55
C75	4030019560	S.CER GRM21BB31C106KE15L	T	61.6/25.3
C76	4030016790	S.CER ECJ0EB1C103K	T	57.8/54.9
C77	4030017460	S.CER ECJ0EB1E102K	T	57.8/50.7
C78	4030017460	S.CER ECJ0EB1E102K	B	58.8/56.6
C79	4030011810	S.CER C1608 JB 1A 224K-T	T	62.6/54.9
C80	4030016930	S.CER ECJ0EB1A104K	T	60.6/52.1
C81	4030017460	S.CER ECJ0EB1E102K	T	66.5/54.9
C82	4030011170	S.CER GRM31M2C2H180JV01L (GRM42-6 CH) [EUR-01]	T	37.3/65.2
	4030011170	S.CER GRM31M2C2H180JV01L (GRM42-6 CH) [EXP-01]	T	
C83	4030011160	S.CER GRM31M2C2H150JV01L (GRM42-6 CH) [EUR-01]	T	39.9/68.6
	4030011160	S.CER GRM31M2C2H150JV01L (GRM42-6 CH) [EXP-01]	T	
C84	4030017420	S.CER ECJ0EC1H470J	T	55/61.6
C85	4030017460	S.CER ECJ0EB1E102K	T	56/61.6
C86	4030017420	S.CER ECJ0EC1H470J	T	81.1/63.7
C87	4030017460	S.CER ECJ0EB1E102K	T	79.8/68.8
C88	4030017460	S.CER ECJ0EB1E102K	T	64.7/49.8
C90	4030017460	S.CER ECJ0EB1E102K	B	87.2/50.3
C92	4030017460	S.CER ECJ0EB1E102K	B	87.2/51.9
C93	4030017390	S.CER ECJ0EC1H180J	B	84.9/49.1
C94	4030017420	S.CER ECJ0EC1H470J	B	78.8/53.2
C99	4030017460	S.CER ECJ0EB1E102K	B	81.7/48.2
C100	4030017620	S.CER ECJ0EC1H100C	B	91.5/35.4
C101	4030017550	S.CER ECJ0EC1H1R5B	T	64.3/29.5
C102	4030017620	S.CER ECJ0EC1H100C	B	97.7/34.4
C103	4030017620	S.CER ECJ0EC1H100C	B	99/32.7
C104	4030017460	S.CER ECJ0EB1E102K	B	100.7/31.3
C105	4030017460	S.CER ECJ0EB1E102K	B	97.4/29.5
C106	4030017420	S.CER ECJ0EC1H470J	B	90.5/49.1
C107	4030017460	S.CER ECJ0EB1E102K	T	82.1/58.3
C108	4030016790	S.CER ECJ0EB1C103K	B	80.1/49.1
C109	4030017460	S.CER ECJ0EB1E102K	B	96.3/35.7
C110	4030017460	S.CER ECJ0EB1E102K	B	100.7/35.7
C111	4030017420	S.CER ECJ0EC1H470J	T	101.8/36.6
C113	4030017540	S.CER ECJ0EC1HR75B	B	100.6/28.1
C114	4030017660	S.CER ECJ0EC1H330J	B	98.8/28.1
C115	4030017660	S.CER ECJ0EC1H330J	B	101.5/23.5
C116	4030016790	S.CER ECJ0EB1C103K	B	100.6/23.5
C117	4030017460	S.CER ECJ0EB1E102K	B	99.7/23.5
C118	4030017530	S.CER ECJ0EC1H0R5B	B	103.1/32
C119	4030017460	S.CER ECJ0EB1E102K	B	107.7/31.8
C120	4030016930	S.CER ECJ0EB1A104K	B	107.7/32.9
C121	4030017420	S.CER ECJ0EC1H470J	B	104/30.8
C122	4030017420	S.CER ECJ0EC1H470J	B	107.7/33.8
C123	4030017420	S.CER ECJ0EC1H470J	B	105/29.2
C124	4030017440	S.CER ECJ0EC1H221J	B	106/26.2
C126	4030017660	S.CER ECJ0EC1H330J	B	97.9/25.3
C127	4030017640	S.CER ECJ0EC1H150J	B	93.9/23.3
C129	4030017340	S.CER ECJ0EC1H010B	B	105/27.6
C132	4030016930	S.CER ECJ0EB1A104K	T	93.8/11.1
C133	4030017660	S.CER ECJ0EC1H330J	B	104.1/27.6
C134	4030017390	S.CER ECJ0EC1H180J	B	97.9/23.5
C135	4030017460	S.CER ECJ0EB1E102K	T	79.5/20
C136	4030017340	S.CER ECJ0EC1H010B	B	98.8/23.5
C137	4030017460	S.CER ECJ0EB1E102K	T	97.1/12.9
C138	4030017420	S.CER ECJ0EC1H470J	B	101.6/18.7
C139	4030016930	S.CER ECJ0EB1A104K	B	106.3/35.7
C140	4030016930	S.CER ECJ0EB1A104K	T	83.2/28.7
C141	4030017460	S.CER ECJ0EB1E102K	T	77.1/22.2
C142	4030017460	S.CER ECJ0EB1E102K	T	78.4/15.3
C143	4030017460	S.CER ECJ0EB1E102K	B	80/22.2
C144	4030017420	S.CER ECJ0EC1H470J	T	98.8/18.7
C145	4030017460	S.CER ECJ0EB1E102K	B	103.8/22.5
C146	4550000560	S.TAN TEESVA 1V 334M8R	T	85.8/23.4
C147	4550002980	S.TAN TEESVA 1C 225M8R	T	81.6/23.4
C148	4030019560	S.CER GRM21BB31C106KE15L	T	109.7/30.5
C149	4550000560	S.TAN TEESVA 1V 334M8R	T	83.7/23.4
C150	4030017460	S.CER ECJ0EB1E102K	T	99.5/11.1
C151	4030016930	S.CER ECJ0EB1A104K	T	77/33.4
C152	4030017420	S.CER ECJ0EC1H470J	T	74.3/33.4
C153	4030017420	S.CER ECJ0EC1H470J	T	75.2/33.4
C154	4030017420	S.CER ECJ0EC1H470J	T	76.1/33.4
C155	4030017450	S.CER ECJ0EB1E271K	T	81.6/33.4
C156	4030017580	S.CER ECJ0EC1H060C	B	91/30.4
C157	4030017430	S.CER ECJ0EC1H101J	B	76.9/24.8
C158	4030017360	S.CER ECJ0EC1H030B	B	86.3/31.5
C159	4030017580	S.CER ECJ0EC1H0		

[MAIN-A UNIT]

REF NO.	PARTS NO.	DESCRIPTION	M.	H/V LOCATION
C167	4030017920	S.CER ECJ0EB1A683K	B	13.4/21.5
C168	4030016950	S.CER ECJ0EB1A473K	B	13.4/22.4
C169	4030016950	S.CER ECJ0EB1A473K	B	15.1/21.5
C170	4030017460	S.CER ECJ0EB1E102K	T	19.7/23.5
C172	4030016790	S.CER ECJ0EB1C103K	T	32.3/23
C173	4030016930	S.CER ECJ0EB1A104K	T	14.6/19
C174	4030019560	S.CER GRM21BB31C106KE15L	T	30.5/27.9
C175	4030017460	S.CER ECJ0EB1E102K	T	32.3/29.6
C176	4030017420	S.CER ECJ0EC1H470J	T	30.8/22.7
C177	4030018090	S.CER ECJ0EB1C822K	B	13.4/19.7
C178	4030017430	S.CER ECJ0EC1H101J	B	16.3/19.3
C179	4030016930	S.CER ECJ0EB1A104K	B	18.9/17.4
C180	4550006970	S.TAN TEESVA0G476M8R	T	35.9/30.3
C181	4030016930	S.CER ECJ0EB1A104K	B	29.8/19.3
C182	4030016790	S.CER ECJ0EB1C103K	B	28.5/19.6
C183	4030016930	S.CER ECJ0EB1A104K	B	27.6/18
C184	4030017700	S.CER ECJ0EC1H151J	B	24.9/19.6
C185	4030016930	S.CER ECJ0EB1A104K	B	36.4/30
C186	4030016930	S.CER ECJ0EB1A104K	B	16.9/13.8
C187	4030016930	S.CER ECJ0EB1A104K	B	17.7/2
C188	4030016930	S.CER ECJ0EB1A104K	B	33.3/21.9
C189	4030017460	S.CER ECJ0EB1E102K	B	38.9/19.1
C190	4030016790	S.CER ECJ0EB1C103K	B	35.5/30
C195	4550000550	S.TAN TEESVA 1V 224M8R	T	93.9/16.6
C196	4030017460	S.CER ECJ0EB1E102K	T	97.3/17.1
C197	4030017460	S.CER ECJ0EB1E102K	T	101.9/21.3
C198	4030017490	S.CER C1608 JB 1A 105K-T	T	102.2/20.1
C200	4030016930	S.CER ECJ0EB1A104K	T	76.4/15.3
C201	4030016930	S.CER ECJ0EB1A104K	T	77.4/8
C202	4030016930	S.CER ECJ0EB1A104K	T	80.3/11.3
C203	4030016930	S.CER ECJ0EB1A104K	B	75.8/11.4
C204	4030017420	S.CER ECJ0EC1H470J	B	70.8/6.6
C207	4030017460	S.CER ECJ0EB1E102K	B	73.9/11.3
C208	4030017460	S.CER ECJ0EB1E102K	B	71/14.2
C209	4030017460	S.CER ECJ0EB1E102K	B	70/14.3
C210	4030017460	S.CER ECJ0EB1E102K	B	69.1/14.3
C226	4030017420	S.CER ECJ0EC1H470J	B	65.2/6.8
C242	4030016930	S.CER ECJ0EB1A104K	T	36.9/19
C244	4030018900	S.CER ECJ0EB0J474K	B	126.9/19.5
C245	4030016790	S.CER ECJ0EB1C103K	B	30.3/9.8
C246	4030016930	S.CER ECJ0EB1A104K	B	116.6/18.6
C247	4030016930	S.CER ECJ0EB1A104K	B	39.2/21.1
C249	4030017760	S.CER ECJ0EB1H222K	B	33.3/9.3
C250	4030016930	S.CER ECJ0EB1A104K	B	29.8/5.7
C251	4030016790	S.CER ECJ0EB1C103K	B	125.5/16.9
C252	4030016930	S.CER ECJ0EB1A104K	B	123.7/16.9
C253	4030018860	S.CER ECJ0EB0J105K	B	131.6/16.6
C254	4030017460	S.CER ECJ0EB1E102K	T	133.3/45
C255	4510009680	S.ELE EEEFK1E471P	B	120.1/29.1
C256	4510009250	S.ELE EEEFK1C471P	B	130.5/34.8
C258	4510009680	S.ELE EEEFK1E471P	B	110.2/52.7
C259	4030017460	S.CER ECJ0EB1E102K	B	113.4/58.8
C260	4030017420	S.CER ECJ0EC1H470J	B	105.5/59
C261	4030004760	S.CER C2012 JF 1H 104Z-T	B	129.4/50.6
C262	4030016930	S.CER ECJ0EB1A104K	T	127.8/40.1
C263	4030004760	S.CER C2012 JF 1H 104Z-T	T	124.3/37.1
C264	4030016930	S.CER ECJ0EB1A104K	T	125.7/34.3
C265	4510009680	S.ELE EEEFK1E471P	B	117/41.7
C266	4030019560	S.CER GRM21BB31C106KE15L	T	127.8/44
C267	4030017460	S.CER ECJ0EB1E102K	T	125.7/38.1
C268	4030019560	S.CER GRM21BB31C106KE15L	T	124.3/33.7
C269	4030017460	S.CER ECJ0EB1E102K	B	122.1/48.2
C270	4030017460	S.CER ECJ0EB1E102K	T	107.7/46.3
C271	4030019560	S.CER GRM21BB31C106KE15L	T	105.5/44.3
C272	4030019560	S.CER GRM21BB31C106KE15L	B	129.4/43.4
C273	4030017460	S.CER ECJ0EB1E102K	B	120.7/22.8
C274	4030019560	S.CER GRM21BB31C106KE15L	T	42.5/19.6
C275	4030017460	S.CER ECJ0EB1E102K	T	107.7/37.4
C276	4030017460	S.CER ECJ0EB1E102K	B	128.6/42
C280	4030016790	S.CER ECJ0EB1C103K	B	37.1/8.9
C282	4030016930	S.CER ECJ0EB1A104K	B	78.3/30.3
C283	4030019560	S.CER GRM21BB31C106KE15L	B	76.9/29.8
C284	4030017420	S.CER ECJ0EC1H470J	B	78.7/32.7
C285	4030017460	S.CER ECJ0EB1E102K	B	94.5/30.4
C286	4030017360	S.CER ECJ0EC1H030B	B	94.5/29.5
C287	4030017770	S.CER ECJ0EB1E332K	B	93.8/13.8
C288	4030016930	S.CER ECJ0EB1A104K	T	114.9/16
C289	4030018860	S.CER ECJ0EB0J105K	T	114.9/15.1
C290	4030017460	S.CER ECJ0EB1E102K	T	114.9/16.9
C291	4030017460	S.CER ECJ0EB1E102K	T	114.9/14.2
C292	4030017420	S.CER ECJ0EC1H470J	B	116.6/20.2
C293	4030017460	S.CER ECJ0EB1E102K	T	116.6/27.5
C294	4030017460	S.CER ECJ0EB1E102K	T	114.9/11.7
C295	4030018860	S.CER ECJ0EB0J105K	T	111.2/11.7
C297	4030017600	S.CER ECJ0EC1H080C	B	86.1/32.8
C298	4030017640	S.CER ECJ0EC1H150J	B	83.6/31.5
C299	4030017600	S.CER ECJ0EC1H080C	B	82/31.5
C300	4030017600	S.CER ECJ0EC1H080C	B	84.5/31.5
C301	4030017460	S.CER ECJ0EB1E102K	B	94/32.3
C302	4030017620	S.CER ECJ0EC1H100C	B	80.7/39.3
C303	4030017460	S.CER ECJ0EB1E102K	B	81.6/36.4
C304	4030017620	S.CER ECJ0EC1H100C	B	76.9/25.7
C305	4030017500	S.CER ECJ0EC1H560J	B	64.1/23.3
C306	4030017570	S.CER ECJ0EC1H040B	B	63.4/25
C307	4030017590	S.CER ECJ0EC1H070C	B	61.6/23.2
C308	4030017360	S.CER ECJ0EC1H030B	B	61.6/24.8
C309	4030016790	S.CER ECJ0EB1C103K	B	67.1/22.4
C310	4030017460	S.CER ECJ0EB1E102K	B	19.4/5.7
C311	4030017460	S.CER ECJ0EB1E102K	T	11.8/12.8
C312	4030016930	S.CER ECJ0EB1A104K	T	49.2/21.2
C314	4030016790	S.CER ECJ0EB1C103K	B	110.5/33.8
C315	4030016970	S.CER ECJ0EB1C223K	B	26.7/22.9
C316	4030017740	S.CER ECJ0EB1E821K	B	24.9/24.6
C317	4030017740	S.CER ECJ0EB1E821K	B	21.3/24.6

[MAIN-A UNIT]

REF NO.	PARTS NO.	DESCRIPTION	M.	H/V LOCATION
C318	4030016930	S.CER ECJ0EB1A104K	B	22.2/24.6
C320	4030016940	S.CER ECJ0EB1A393K	B	29.1/18.6
C321	4030016930	S.CER ECJ0EB1A104K	T	27.5/18.6
C322	4030017790	S.CER ECJ0EB1E682K	T	27.5/17.7
C325	4030016970	S.CER ECJ0EB1C223K	T	27.5/21.3
C330	4550007400	S.TAN F931A225MAABMA	T	78.8/53.9
C333	4030017420	S.CER ECJ0EC1H470J	B	40.4/40.7
C335	4030017460	S.CER ECJ0EB1E102K	B	95.4/33.2
C337	4030017460	S.CER ECJ0EB1E102K	T	82.6/31.4
C339	4030017590	S.CER ECJ0EC1H070C	B	52.7/40.4
C342	4550007550	S.TAN F931V334MAABMA	T	78.3/66
C343	4030017460	S.CER ECJ0EB1E102K	B	51.5/39.1
C347	4030017460	S.CER ECJ0EB1E102K	T	52.1/24.3
C348	4030017460	S.CER ECJ0EB1E102K	T	59.3/20.2
C349	4030016930	S.CER ECJ0EB1A104K	B	21/17.7
C350	4030017920	S.CER ECJ0EB1A683K	T	95.4/13.8
C351	4030016780	S.CER ECJ0EB1C153K	B	131.6/18.7
C353	4030017380	S.CER ECJ0EC1H050B	B	98.8/20.3
C354	4030017610	S.CER ECJ0EC1H090C	B	92.5/23.3
C355	4030017560	S.CER ECJ0EC1H2R5B	B	105.1/22.1
C356	4030017590	S.CER ECJ0EC1H070C	B	107.7/23.2
C357	4030016930	S.CER ECJ0EB1A104K	T	103.6/34.2
C359	4030018860	S.CER ECJ0EB0J105K	B	29.4/18
C360	4030017380	S.CER ECJ0EC1H050B	B	107.3/26.7
C361	4030016930	S.CER ECJ0EB1A104K	B	56.7/6.3
C362	4030017460	S.CER ECJ0EB1E102K	T	133.3/62.5
C363	4030016780	S.CER ECJ0EB1C153K	T	36.4/37.9
C364	4030017420	S.CER ECJ0EC1H470J	T	79.8/67.8
C366	4030017460	S.CER ECJ0EB1E102K	B	69.1/61.6
C367	4030017510	S.CER ECJ0EC1H680J	B	95.1/57.2
C368	4030017460	S.CER ECJ0EB1E102K	B	95.1/68.3
C369	4030017510	S.CER ECJ0EC1H680J	B	93.9/68.3
C371	4030017460	S.CER ECJ0EB1E102K	B	106.5/59
C372	4030017460	S.CER ECJ0EB1E102K	T	60.2/67.2
C375	4030017460	S.CER ECJ0EB1E102K	B	122.5/64.9
C376	4030017380	S.CER ECJ0EC1H050B	B	107.3/25.8
C377	4030017510	S.CER ECJ0EC1H680J	B	65.7/61.6
C378	4030017460	S.CER ECJ0EB1E102K	B	23/14.9
C379	4030016790	S.CER ECJ0EB1C103K	B	30.3/10.7
C380	4030017640	S.CER ECJ0EC1H150J	B	90.7/59.3
C381	4030017640	S.CER ECJ0EC1H150J	B	90/58.2
C382	4030017460	S.CER ECJ0EB1E102K	B	75.8/9.1
C383	4030016930	S.CER ECJ0EB1A104K	T	36.4/36.2
C384	4030016930	S.CER ECJ0EB1A104K	T	51.1/29.4
C385	4030016930	S.CER ECJ0EB1A104K	T	53.5/33.5
C388	4030011600	S.CER C1608 JB 1E 104K-T	T	110.5/48.7
C390	4030017420	S.CER ECJ0EC1H470J	B	74.6/40.6
C391	4030017460	S.CER ECJ0EB1E102K	B	75.7/40.6
C392	4030017390	S.CER ECJ0EC1H180J	B	61.3/39.1
C394	4030016930	S.CER ECJ0EB1A104K	T	52.8/32.2
C395	4030016930	S.CER ECJ0EB1A104K	T	45.7/30.4
C396	4030016930	S.CER ECJ0EB1A104K	T	53.9/29.3
C397	4030016790	S.CER ECJ0EB1C103K	B	39.6/31.5
C398	4030016790	S.CER ECJ0EB1C103K	T	47.4/28.6
C399	4030016790	S.CER ECJ0EB1C103K	B	39.6/32.5
C401	4030017390	S.CER ECJ0EC1H180J	T	88.1/64.1
C402	4030011160	S.CER GRM31M2C2H150JV01L (GRM42-6 CH) [USA-01]	B	36.2/68.7
	4030011160	S.CER GRM31M2C2H150JV01L (GRM42-6 CH) [EXP-02]	B	
	4030011160	S.CER GRM31M2C2H150JV01L (GRM42-6 CH) [CHN-01]	B	
C403	4030011170	S.CER GRM31M2C2H180JV01L (GRM42-6 CH) [USA-01]	B	35/65.3
	4030011170	S.CER GRM31M2C2H180JV01L (GRM42-6 CH) [EXP-02]	B	
	4030011170	S.CER GRM31M2C2H180JV01L (GRM42-6 CH) [CHN-01]	B	
C404	4030011180	S.CER GRM31M2C2H220JV01L (GRM42-6 CH)	B	20.4/58.7
C408	4030017460	S.CER ECJ0EB1E102K	B	43.9/57.9
C409	4030017460	S.CER ECJ0EB1E102K	B	38/52.6
C411	4030017460	S.CER ECJ0EB1E102K [USA-01]	T	42.2/55.4
	4030017460	S.CER ECJ0EB1E102K [EXP-02]	T	
	4030017460	S.CER ECJ0EB1E102K [CHN-01]	T	
C431	4030017440	S.CER ECJ0EC1H221J	B	113.4/59.7
C436	4030017460	S.CER ECJ0EB1E102K	T	114.9/8
C437	4030017460	S.CER ECJ0EB1E102K	B	116.7/9.6
C440	4030017630	S.CER ECJ0EC1H120J	B	27/44.3
C442	4030017570	S.CER ECJ0EC1H040B	B	24.6/49.8
C443	4030017420	S.CER ECJ0EC1H470J	T	40.3/55
C451	4030019560	S.CER GRM21BB31C106KE15L	T	67.9/53.9
C456	4030017380	S.CER ECJ0EC1H050B	B	88.6/60.4
C457	4030017460	S.CER ECJ0EB1E102K	B	72.5/51.7
C458	4030017460	S.CER ECJ0EB1E102K	B	85/58.2
C459	4030017420	S.CER ECJ0EC1H470J	B	85/57.3
C460	4030017390	S.CER ECJ0EC1H180J	B	88.3/58.2
C461	4030017460	S.CER ECJ0EB1E102K	B	85/56.4
C462	4030017460	S.CER ECJ0EB1E102K	T	83.1/58.3
C463	4030017690	S.CER ECJ0EC1H121J	T	53.9/27.9
C464	4030018860	S.CER		

[MAIN-A UNIT]

REF NO.	PARTS NO.	DESCRIPTION	M.	H/V LOCATION
C478	4030017460	S.CER ECJ0EB1E102K	T	72.2/37.7
C479	4030017460	S.CER ECJ0EB1E102K	T	72/40.4
C480	4030017460	S.CER ECJ0EB1E102K	T	73.9/40.4
C481	4030017460	S.CER ECJ0EB1E102K	T	53.8/9.8
C482	4030017460	S.CER ECJ0EB1E102K	T	101.9/22.2
C484	4030019120	S.CER GRM188B31E105KA75D	T	115.8/49.5
J1	6510026770	S.CON AXK540147YG	T	23/8.3
J2	6510022472	S.CON 40FLT-SM2-TB(LF)(SN)(M)	T	67.5/10.6
J4	6450000140	CON HSJ0807-01-010		
J6	6510022891	S.CON B13B-ZR-SM4-TF(LF)(SN)	T	120/17.2
J7	6510014961	S.CON B2B-ZR-SM4-TF(LF)(SN)	T	130.5/27.3
S1	2260003180	S.SWI MINISMD0C050F-2 CN	T	114.1/33.8
W1	7120000470	JUM ERDS2T0		
W2	8900011863	CAB OPC-1195C <TJM>!		
EP1	6910018460	S.BEA MMZ1005Y102C-T	B	106.3/34.8
EP2	6910011560	BEA HF70BB4.5X5X1.6 [USA-01]		
	6910011560	BEA HF70BB4.5X5X1.6 [EXP-02]		
	6910011560	BEA HF70BB4.5X5X1.6 [CHN-01]		
EP3	6910011560	BEA HF70BB4.5X5X1.6 [USA-01]		
	6910011560	BEA HF70BB4.5X5X1.6 [EXP-02]		
	6910011560	BEA HF70BB4.5X5X1.6 [CHN-01]		
EP4	6910010280	BEA HF70BB9.5X10.4X4.9		
EP5	6910010280	BEA HF70BB9.5X10.4X4.9		
EP7	6910018460	S.BEA MMZ1005Y102C-T	B	84.7/24.8
EP8	6910018460	S.BEA MMZ1005Y102C-T	T	84.1/28.7
EP9	6910018460	S.BEA MMZ1005Y102C-T	T	103.1/21.8
MP1	8510019340	S.CAS 3179 VCO CASE Y1142	B	99.2/27.3

[FRONT UNIT]

REF NO.	PARTS NO.	DESCRIPTION	M.	H/V LOCATION
IC1	1140015150	S.IC HD64F2238BTF13V (FX-3179A)	B	67.8/23
IC2	1110005771	S.IC S-80942CNMC-G9CT2G	B	89.1/19.3
IC3	1130012430	S.IC S-24CS64A01-T8T1G	B	90.2/15.7
IC5	1110005340	S.IC NJM12902V-TE1-#ZZZB	B	25.5/23.3
IC6	1130009090	S.IC LC75834W-TLM-E	B	43/21.2
Q1	1530002851	S.TRA 2SC4116-BE(T85R,F)	B	33.6/16.2
Q2	1590001050	S.TRA DTC114TUA T106	B	33.7/19.8
Q3	1590000430	S.TRA DTC144EUA T106	B	35/27
Q5	1590001050	S.TRA DTC114TUA T106	B	33.7/22.3
D1	1790000951	S.ZEN MAZ8056GML	T	13.4/17.1
D2	1790000951	S.ZEN MAZ8056GML	T	5.2/17.1
D3	1790000951	S.ZEN MAZ8056GML	B	18.1/12.3
D5	1790001251	S.DIO MA2S1110GL	B	61.6/15.7
D6	1790001261	S.DIO MA2S077G0L	B	78/13.8
X1	6050011830	S.XTA CR-774 SMD-49TB 12.288 MHz	B	82.3/16.5
L1	6200003640	S.COI MLF1608E 100K-T	B	11.6/17.1
L2	6200001981	S.COI NLV25T-1R0J	B	59.5/9.7
R7	7030009160	S.RES ERJ2GEJ 181 X (180)	B	35.7/16.2
R8	7030009160	S.RES ERJ2GEJ 181 X (180)	B	36.6/16.2
R9	7030005000	S.RES ERJ2GEJ 471 X (470)	B	37.5/16.2
R11	7030009280	S.RES ERJ2GEJ 391 X	B	33.1/18
R12	7030009140	S.RES ERJ2GEJ 272 X (2.7K)	B	34.7/18
R14	7210003330	VAR RK09D1130A1N		
R15	7030005120	S.RES ERJ2GEJ 102 X (1K)	B	7.2/17.1
R16	7030005120	S.RES ERJ2GEJ 102 X (1K)	B	16.5/13.2
R18	7030005090	S.RES ERJ2GEJ 104 X (100K)	T	8.2/17.1
R19	7030005090	S.RES ERJ2GEJ 104 X (100K)	B	19.7/13.2
R20	7030008300	S.RES ERJ2GEJ 184 X (180K)	B	61.3/29.9
R21	7030005720	S.RES ERJ2GEJ 563 X (56K)	B	61.3/30.8
R22	7030005220	S.RES ERJ2GEJ 223 X (22K)	B	61.3/31.7
R23	7030005240	S.RES ERJ2GEJ 473 X (47K)	B	30.9/27.9
R24	7030005240	S.RES ERJ2GEJ 473 X (47K)	B	30.9/27
R25	7030005220	S.RES ERJ2GEJ 223 X (22K)	B	32.6/28.8
R26	7030005240	S.RES ERJ2GEJ 473 X (47K)	B	29.2/27
R27	7030005240	S.RES ERJ2GEJ 473 X (47K)	B	26.9/27.9
R28	7030005040	S.RES ERJ2GEJ 472 X (4.7K)	B	30.9/26.1
R29	7030008290	S.RES ERJ2GEJ 183 X (18K)	B	32.6/27.9
R32	7030007340	S.RES ERJ2GEJ 153 X (15K)	B	30.9/23.3
R33	7030005220	S.RES ERJ2GEJ 223 X (22K)	B	30.9/24.2
R34	7030005060	S.RES ERJ2GEJ 333 X (33K)	B	30.9/22.4
R35	7030005070	S.RES ERJ2GEJ 683 X (68K)	B	30.9/21.5
R36	7030005070	S.RES ERJ2GEJ 683 X (68K)	B	30.9/20.6
R37	7030005070	S.RES ERJ2GEJ 683 X (68K)	B	29.2/21.5
R38	7030005070	S.RES ERJ2GEJ 683 X (68K)	B	29.2/22.4
R39	7030005070	S.RES ERJ2GEJ 683 X (68K)	B	29.2/23.3
R40	7030005240	S.RES ERJ2GEJ 473 X (47K)	B	20.1/26.1
R41	7030005600	S.RES ERJ2GEJ 273 X (27K)	B	20.1/27.9
R42	7030005240	S.RES ERJ2GEJ 473 X (47K)	B	23.6/27.9
R43	7030007350	S.RES ERJ2GEJ 393 X (39K)	B	25.2/27.9
R44	7030005100	S.RES ERJ2GEJ 154 X (150K)	B	21.8/27
R45	7030005160	S.RES ERJ2GEJ 105 X (1M)	B	23.6/28.8
R46	7030005120	S.RES ERJ2GEJ 102 X (1K)	B	33.4/3.3
R47	7030009140	S.RES ERJ2GEJ 272 X (2.7K)	B	33.4/5.1
R48	7030010040	S.RES ERJ2GEJ-JPW	B	28/18.3
R51	7030005090	S.RES ERJ2GEJ 104 X (100K)	B	59.5/15.7
R58	7030005050	S.RES ERJ2GEJ 103 X (10K)	B	85.8/13.6
R60	7030005090	S.RES ERJ2GEJ 104 X (100K)	B	84/8.6
R65	7030005120	S.RES ERJ2GEJ 102 X (1K)	B	59.7/29.9
R68	7030005090	S.RES ERJ2GEJ 104 X (100K)	B	85.8/15.2
R73	7030005050	S.RES ERJ2GEJ 103 X (10K)	B	45.2/14.6
R74	7030005050	S.RES ERJ2GEJ 103 X (10K)	B	47/14.6
R75	7030005050	S.RES ERJ2GEJ 103 X (10K)	B	44.3/14.6
R76	7030005120	S.RES ERJ2GEJ 102 X (1K)	T	10.4/17.1
R77	7030005030	S.RES ERJ2GEJ 152 X (1.5K)	B	72.5/9.3
R78	7030005240	S.RES ERJ2GEJ 473 X (47K)	B	42.2/14.3
R82	7030005090	S.RES ERJ2GEJ 104 X (100K)	B	39/14.6
R83	7030005090	S.RES ERJ2GEJ 104 X (100K)	B	40.8/14.6
R84	7030005090	S.RES ERJ2GEJ 104 X (100K)	B	39.9/14.6
R90	7030006610	S.RES ERJ2GEJ 394 X (390K)	B	53.8/4.1
R101	7030008010	S.RES ERJ2GEJ 123 X (12K)	B	77.4/14.9
R102	7030008010	S.RES ERJ2GEJ 123 X (12K)	B	77.4/12.7
R103	7030008010	S.RES ERJ2GEJ 123 X (12K)	B	78.8/12.2
R104	7030005090	S.RES ERJ2GEJ 104 X (100K)	B	75.7/14.9
R105	7030005530	S.RES ERJ2GEJ 100 X (10)	B	77.4/15.8
R106	7030005160	S.RES ERJ2GEJ 105 X (1M)	B	78.8/17.2
R107	7030005050	S.RES ERJ2GEJ 103 X (10K)	B	86.7/18.5
R108	7030005120	S.RES ERJ2GEJ 102 X (1K)	B	74/29.4
R109	7030005120	S.RES ERJ2GEJ 102 X (1K)	B	72.6/30.9
R110	7030010040	S.RES ERJ2GEJ-JPW	B	59.7/27.7
R111	7030005120	S.RES ERJ2GEJ 102 X (1K)	B	57.5/22.2
R112	7030005120	S.RES ERJ2GEJ 102 X (1K)	B	57.5/23.2
R113	7030005090	S.RES ERJ2GEJ 104 X (100K)	B	75.7/15.8
R114	7030005090	S.RES ERJ2GEJ 104 X (100K)	B	78/25.8
R115	7410001130	S.ARR EXB28V102JX	B	57.5/25.2
R116	7030005120	S.RES ERJ2GEJ 102 X (1K)	B	60.6/17.3
R117	7030005120	S.RES ERJ2GEJ 102 X (1K)	B	71/12.7
R118	7030005120	S.RES ERJ2GEJ 102 X (1K)	B	71.9/14.6
R119	7030005120	S.RES ERJ2GEJ 102 X (1K)	B	73.5/14.9
R120	7030005120	S.RES ERJ2GEJ 102 X (1K)	B	75.7/30.3
R121	7030005120	S.RES ERJ2GEJ 102 X (1K)	B	72.9/31.8
R122	7030005120	S.RES ERJ2GEJ 102 X (1K)	B	71.3/32.2
R123	7030005090	S.RES ERJ2GEJ 104 X (100K)	B	58.9/17.3
R124	7030005120	S.RES ERJ2GEJ 102 X (1K)	B	58.9/18.2
R125	7030005120	S.RES ERJ2GEJ 102 X (1K)	B	58.9/19.1

M.=Mounted side (T: Mounted on the Top side, B: Mounted on the Bottom side)  
S.=Surface mount



[FRONT UNIT]

REF NO.	PARTS NO.	DESCRIPTION	M.	H/V LOCATION
R127	7030005160	S.RES ERJ2GEJ 105 X (1M)	B	78/28.5
R128	7030005050	S.RES ERJ2GEJ 103 X (10K)	B	30.9/25.2
C1	4030018100	S.CER ECJ0EB1H681K	B	42.2/15.2
C2	4030017420	S.CER ECJ0EC1H470J	B	84/7.7
C3	4030017420	S.CER ECJ0EC1H470J	B	28.5/6.1
C4	4030017420	S.CER ECJ0EC1H470J	B	47.2/5
C5	4030017420	S.CER ECJ0EC1H470J	B	56.4/5.5
C6	4030017420	S.CER ECJ0EC1H470J	B	81/27.6
C7	4030017420	S.CER ECJ0EC1H470J	B	16.5/11.6
C8	4030017460	S.CER ECJ0EB1E102K	B	13.7/17.1
C9	4030017460	S.CER ECJ0EB1E102K	T	11.3/17.1
C10	4030017460	S.CER ECJ0EB1E102K	T	20.3/13.1
C11	4030017420	S.CER ECJ0EC1H470J	T	7.3/17.1
C12	4030017460	S.CER ECJ0EB1E102K	T	18.3/13.1
C14	4030017460	S.CER ECJ0EB1E102K	B	29.2/28.8
C15	4030016780	S.CER ECJ0EB1C153K	B	29.2/27.9
C16	4030016930	S.CER ECJ0EB1A104K	B	29.2/26.1
C17	4030017740	S.CER ECJ0EB1E821K	B	26.9/28.8
C19	4030016930	S.CER ECJ0EB1A104K	B	32.6/27
C20	4030017460	S.CER ECJ0EB1E102K	B	30.9/19.7
C21	4030017460	S.CER ECJ0EB1E102K	B	29.2/20.6
C22	4030018140	S.CER ECJ0EB1H391K	B	26.2/18.3
C23	4030016790	S.CER ECJ0EB1C103K	B	29.2/24.2
C24	4030017420	S.CER ECJ0EC1H470J	B	24.4/18.3
C25	4030016790	S.CER ECJ0EB1C103K	B	21.8/28.8
C26	4030016930	S.CER ECJ0EB1A104K	B	20.1/27
C27	4030017450	S.CER ECJ0EB1E271K	B	21.8/27.9
C28	4030016930	S.CER ECJ0EB1A104K	B	25.3/18.3
C29	4550006050	S.TAN TEESVA 0J 106M8R	B	25.5/16.1
C31	4030016930	S.CER ECJ0EB1A104K	B	33.4/4.2
C34	4030017420	S.CER ECJ0EC1H470J	B	56.4/4.5
C36	4030016930	S.CER ECJ0EB1A104K	B	85.8/16.8
C37	4030017420	S.CER ECJ0EC1H470J	B	85.6/20.1
C38	4030017420	S.CER ECJ0EC1H470J	B	78.8/9.3
C41	4030017460	S.CER ECJ0EB1E102K	B	20.1/28.8
C50	4030017420	S.CER ECJ0EC1H470J	B	62.1/9.3
C54	4030017420	S.CER ECJ0EC1H470J	B	63/9.3
C69	4030017420	S.CER ECJ0EC1H470J	B	67.4/1.7
C74	4030017420	S.CER ECJ0EC1H470J	B	61.7/1.7
C75	4030016930	S.CER ECJ0EB1A104K	B	46.1/14.6
C76	4030016930	S.CER ECJ0EB1A104K	B	25.2/28.8
C77	4030016950	S.CER ECJ0EB1A473K	B	71.6/10.9
C78	4030017460	S.CER ECJ0EB1E102K	B	8.9/17.1
C79	4030016930	S.CER ECJ0EB1A104K	B	47.9/14.6
C80	4030016930	S.CER ECJ0EB1A104K	B	43.4/14.6
C81	4030017460	S.CER ECJ0EB1E102K	T	9.2/17.1
C82	4030017420	S.CER ECJ0EC1H470J	B	33.1/26.1
C83	4030017420	S.CER ECJ0EC1H470J	B	23.5/18.3
C84	4030017420	S.CER ECJ0EC1H470J	B	21.8/26.1
C85	4030017420	S.CER ECJ0EC1H470J	B	29.2/19.7
C87	4030016930	S.CER ECJ0EB1A104K	B	30.9/18
C93	4030017460	S.CER ECJ0EB1E102K	B	56.9/9.2
C101	4030016930	S.CER ECJ0EB1A104K	B	76.1/13.3
C102	4030016930	S.CER ECJ0EB1A104K	B	77.4/11.8
C103	4030016930	S.CER ECJ0EB1A104K	B	75.2/13.3
C104	4030017400	S.CER ECJ0EC1H220J	B	78.8/15.4
C105	4030017600	S.CER ECJ0EC1H080C	B	77.4/16.7
C106	4030017640	S.CER ECJ0EC1H150J	B	77.4/17.6
C107	4030017030	S.CER ECJ0EB1A273K	B	91.3/18.5
C111	4030016930	S.CER ECJ0EB1A104K	B	86.7/20.1
C112	4550006780	S.TAN TEESVB2 0J 476M8R	B	56.2/16.8
C113	4030018910	S.CER C1608 JB 0J 475K-T	B	78/18.9
C114	4030017420	S.CER ECJ0EC1H470J	B	56.9/10.1
C115	4030016930	S.CER ECJ0EB1A104K	B	75.8/18.9
C116	4030016930	S.CER ECJ0EB1A104K	B	78/20
C117	4030016930	S.CER ECJ0EB1A104K	B	78/20.9
C118	4030016930	S.CER ECJ0EB1A104K	B	78/24.9
C119	4030016930	S.CER ECJ0EB1A104K	B	78/23.1
C120	4030016930	S.CER ECJ0EB1A104K	B	78/24
C123	4030017460	S.CER ECJ0EB1E102K	B	76.2/29.4
C124	4030016930	S.CER ECJ0EB1A104K	B	59.7/28.6
C125	4030016930	S.CER ECJ0EB1A104K	B	53.8/5
C126	4030017460	S.CER ECJ0EB1E102K	B	25.2/4.2
C128	4030016930	S.CER ECJ0EB1A104K	T	14.6/19.3
C129	4030017460	S.CER ECJ0EB1E102K	T	13.7/19.3
C130	4030017460	S.CER ECJ0EB1E102K	B	85.7/8.6
C131	4030018860	S.CER ECJ0EB0J105K	B	32.6/25.2
J1	6450002210	CON 3017-8821 <KIN>		
J2	6510022472	S.CON 40FLT-SM2-TB(LF)(SN)(M)	B	70.9/5.7
J3	6510022022	S.CON 14FLT-SM2-TB(LF)(SN)(M)	B	51.8/28.5
DS1	5040002310	S.LED SML-311YTT86	T	64.8/23.5
DS2	5040002310	S.LED SML-311YTT86	T	58.2/23.5
DS3	5040002310	S.LED SML-311YTT86	T	51.6/23.5
DS4	5040002310	S.LED SML-311YTT86	T	31.8/23.5
DS5	5040002310	S.LED SML-311YTT86	T	38.4/23.5
DS6	5040002310	S.LED SML-311YTT86	T	45/23.5
DS7	5040002310	S.LED SML-311YTT86	T	82.5/22.1
DS8	5040002310	S.LED SML-311YTT86	T	65.2/5
DS9	5040002310	S.LED SML-311YTT86	T	36.2/5
DS11	5030003200	LCD A01B011X 3179 LCD		
W1	8900010503	CAB OPC-1046B-1(P0.5,N40,L55) <TJM>		
EP2	8930059170	LCD SRCN-2622-SP-N-W (SHJ)		

M.=Mounted side (T: Mounted on the Top side, B: Mounted on the Bottom side)  
S.=Surface mount

# SECTION 8

# MECHANICAL PARTS

## [CHASSIS PARTS]

REF NO.	ORDER NO.	DESCRIPTION	QTY.
J1	6510004880	MR-DSE-01	1
W1**	8900011800	OPC-1199	1
MP1	8010019065	2601 CHASSIS-5	[EUR-01] 1
	8010019065	2601 CHASSIS-5	[EXP-01] 1
	8010019065	2601 CHASSIS-5	[RUS-01] 1
	8010019135	2601 LONG CHASSIS-5	[USA-01] 1
	8010019135	2601 LONG CHASSIS-5	[EXP-02] 1
	8010019135	2601 LONG CHASSIS-5	[CHN-01] 1
	8010019135	2601 LONG CHASSIS-5	[RUS-02] 1
	8110007821	2601 COVER-1	1
MP2	8810008661	SCREW BT B0 3X8 NI-ZC3 (BT)	8
MP3	8810008661	SCREW BT B0 3X8 NI-ZC3 (BT)	2
MP4	8810008661	SCREW BT B0 3X8 NI-ZC3 (BT)	2
MP5	8810008661	SCREW BT B0 3X8 NI-ZC3 (BT)	4
MP6	8810008661	SCREW BT B0 3X8 NI-ZC3 (BT)	4
MP7	8810009991	SCREW BT B0 3X8 NI-ZK3 (BT)	1
MP8	8810009991	SCREW BT B0 3X8 NI-ZK3 (BT)	2

## [FRONT UNIT]

REF NO.	ORDER NO.	DESCRIPTION	QTY.
R14	7210003330	RK09D1130A1N	1
J1	6450002210	3017-8821	1
J2*	6510022472	40FLT-SM2-TB (LF) (SN) (M)	1
J3*	6510022022	14FLT-SM2-TB (LF) (SN) (M)	1
DS11	5030003200	A01B011X	1
SP1	2510001221	C052SB500-14	1
W1**	8900010503	OPC-1046B-1	1
EP2	8930059170	SRCN-2622-SP-N-W	1
MP1	8210025590	3179 FRONT PANEL ASSY (Incl. SP1, MP2, 11)	1
MP2	8310073260	3179 WINDOW PLATE	1
MP3	8510019440	3179 SHIELD PLATE (Incl. MP4)	1
MP4	8930078670	3179 EARTH SPRING	1
MP5	8930078660	3179 KEYBOARD	1
MP6	8610014010	KNOB N-386 (Incl. MP7)	1
MP7	8610007420	KNOB SPRING NO.6601	1
MP8	8930059090	2622 LCD PLATE	1
MP9	8210019350	2622 REFLECTOR	1
MP10	8930059100	2622 LCD FILTER	1
MP11	8930059000	2601 SP NET	1
MP12	8930070850	2979 VOL RUBBER	1
MP13	8810008761	SCREW BT B0 2X8 NI-ZC3 (BT)	3

## [MAIN-A UNIT]

REF NO.	ORDER NO.	DESCRIPTION	QTY.
J1*	6510026770	AXK540147YG	1
J2*	6510022472	40FLT-SM2-TB (LF) (SN) (M)	1
J4	6450000140	HSJ0807-01-010	1
J6*	6510022891	B13B-ZR-SM4-TF (LF) (SN)	1
J7*	6510014961	B2B-ZR-SM4-TF (LF) (SN)	1
S1*	2260003180	MINISMD C050F	1
W1*	7120000470	ERDS2T0	1
W2	8900011863	OPC-1195C	1
EP2*	6910011560	HF70BB4.5X5X1.6	[USA-01] 1
	6910011560	HF70BB4.5X5X1.6	[EXP-02] 1
	6910011560	HF70BB4.5X5X1.6	[CHN-01] 1
EP3*	6910011560	HF70BB4.5X5X1.6	[USA-01] 1
	6910011560	HF70BB4.5X5X1.6	[EXP-02] 1
	6910011560	HF70BB4.5X5X1.6	[CHN-01] 1
EP4*	6910010280	HF70BB9.5X10.4X4.9	1
EP5*	6910010280	HF70BB9.5X10.4X4.9	1
MP1	8510019340	3179 VCO CASE	1
MP2	8510019350	3179 VCO COVER	1
MP3	8510015110	2602 M-PLATE	1
MP4*	8930055841	2490 EARTH SPRING-1	1

## [ACCESSORIES]

REF NO.	ORDER NO.	DESCRIPTION	QTY.
MC1	(Optional)	HM-152	1
W1	(Optional)	OPC-1194A	[EUR-01] 1
	(Optional)	OPC-1194A	[EXP-01] 1
	(Optional)	OPC-1194A	[RUS-01] 1
	(Optional)	OPC-1132A	[USA-01] 1
	(Optional)	OPC-1132A	[EXP-02] 1
	(Optional)	OPC-1132A	[CHN-01] 1
W2	(Optional)	OPC-1132A	[RUS-02] 1
	8900000731	OPC-049A	1
MP1	8010019151	2601 MOBIL BRACKET-1 (Incl. MP2)	1
MP2	8930059160	2601 FELT	2
MP3	8820000530	FLANGE BOLT M4X8 NI	4
MP4	8810000471	SCREW PH (+) M5X12 ZC3	4
MP5	8810005841	SCREW BT A0 5X20 ZC3	4
MP6	8850000150	FLAT WASHER M5 BS NI	4
MP7	8850000391	SPRING WASHER M5 ZC3	4
MP8	8830000121	NUT M5 ZC3	4
MP9	8950005110	2289 MIC HANGER	1
MP10	8310073440	3179 LCD LABEL	1
MP11	8810004700	SCREW BT A0 3X16 SUS	2

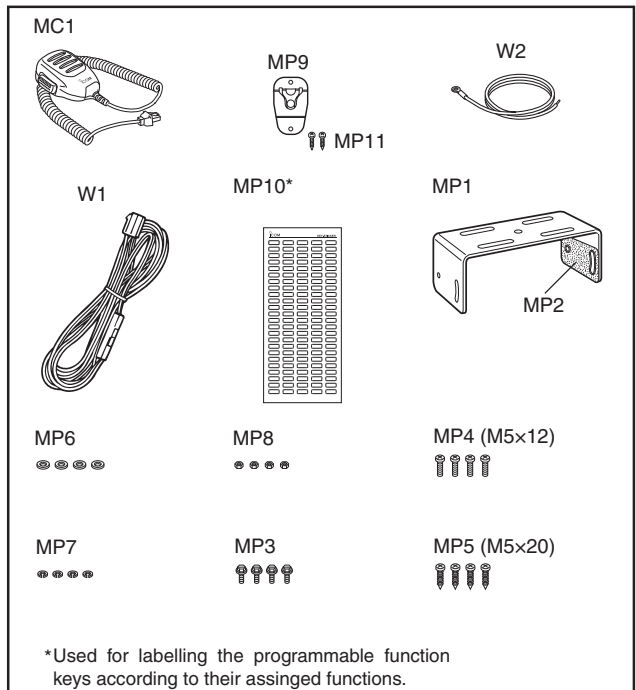

\*: Refer to "BOARD LAYOUTS" for the location.

\*\* : Refer to "GENERAL WIRING" for the connection

**Screw abbreviations** A, B0, BT: Self-tapping PH: Pan head ZK: Black NI-ZU: Nickel-Zinc SUS: Stainless

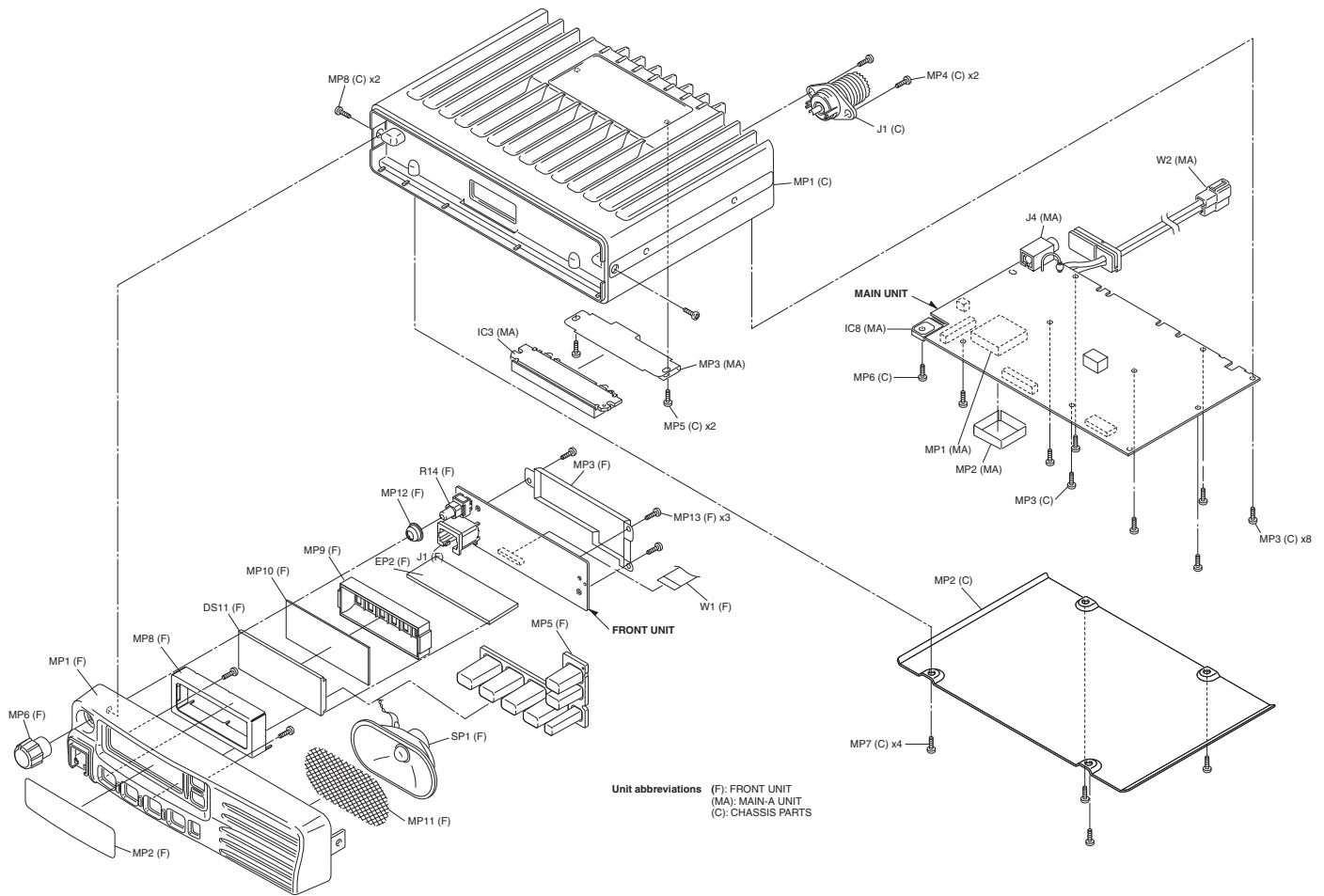



## SECTION 9 BOARD LAYOUTS

### • MAIN-A UNIT (TOP VIEW)

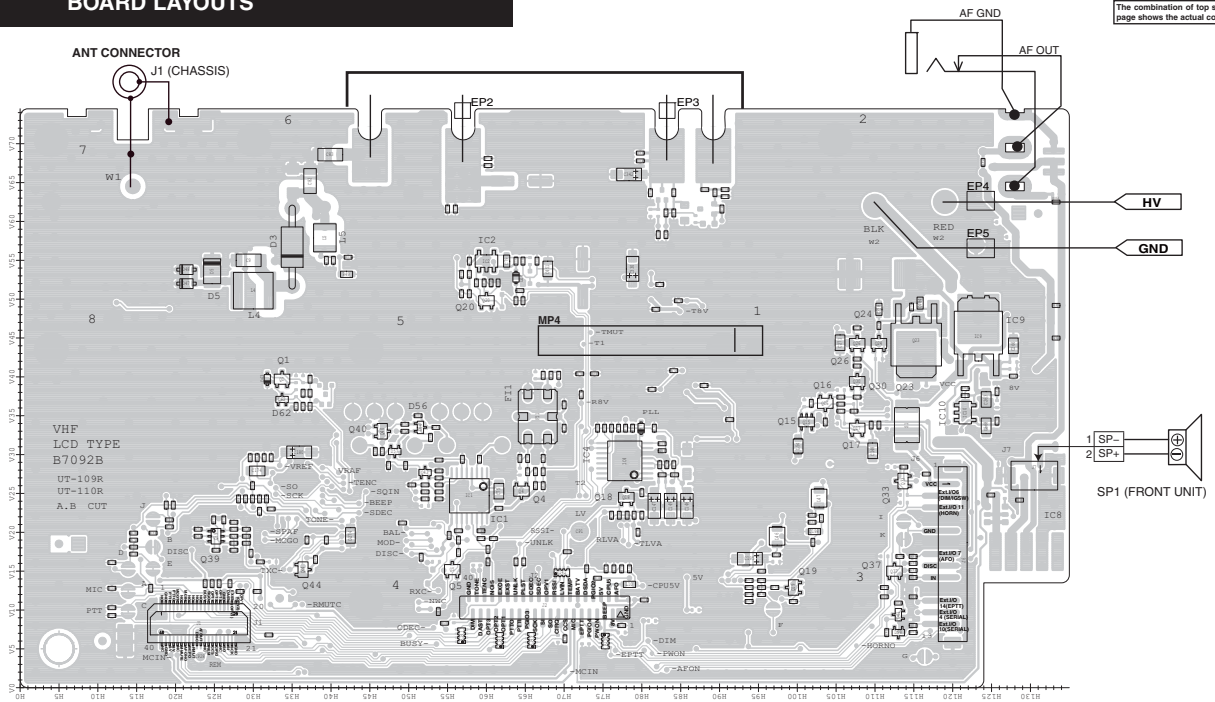

### • FRONT UNIT (TOP VIEW)

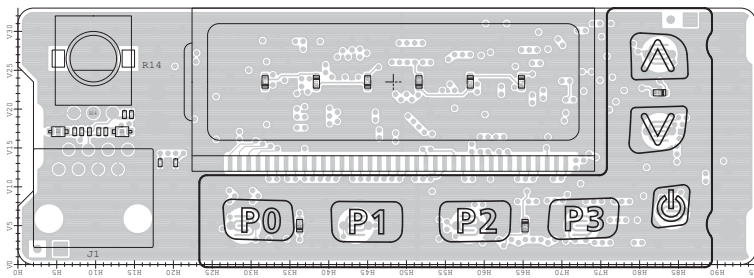



# SECTION 10 GENERAL WIRING

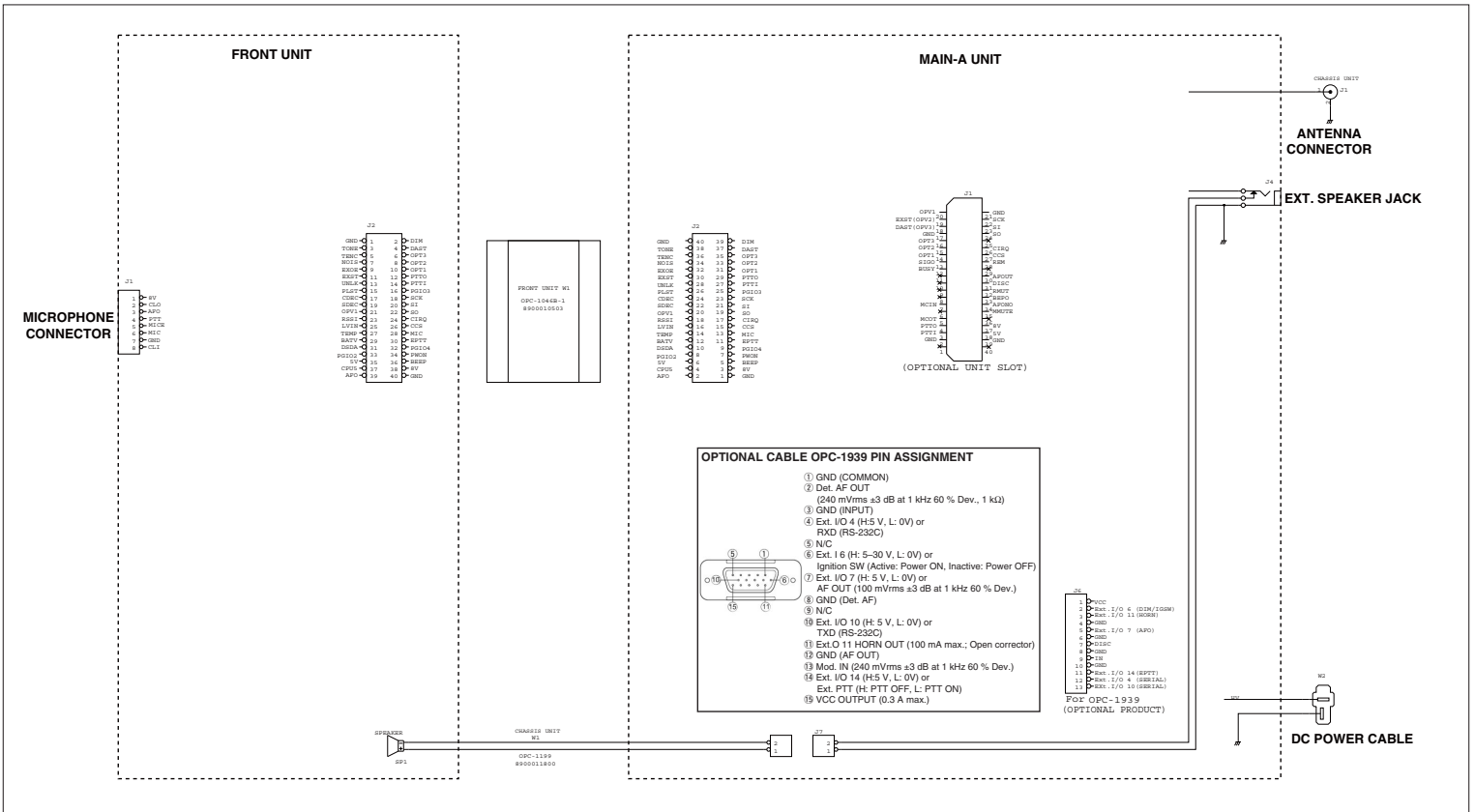

**SECTION 11 BLOCK DIAGRAM**

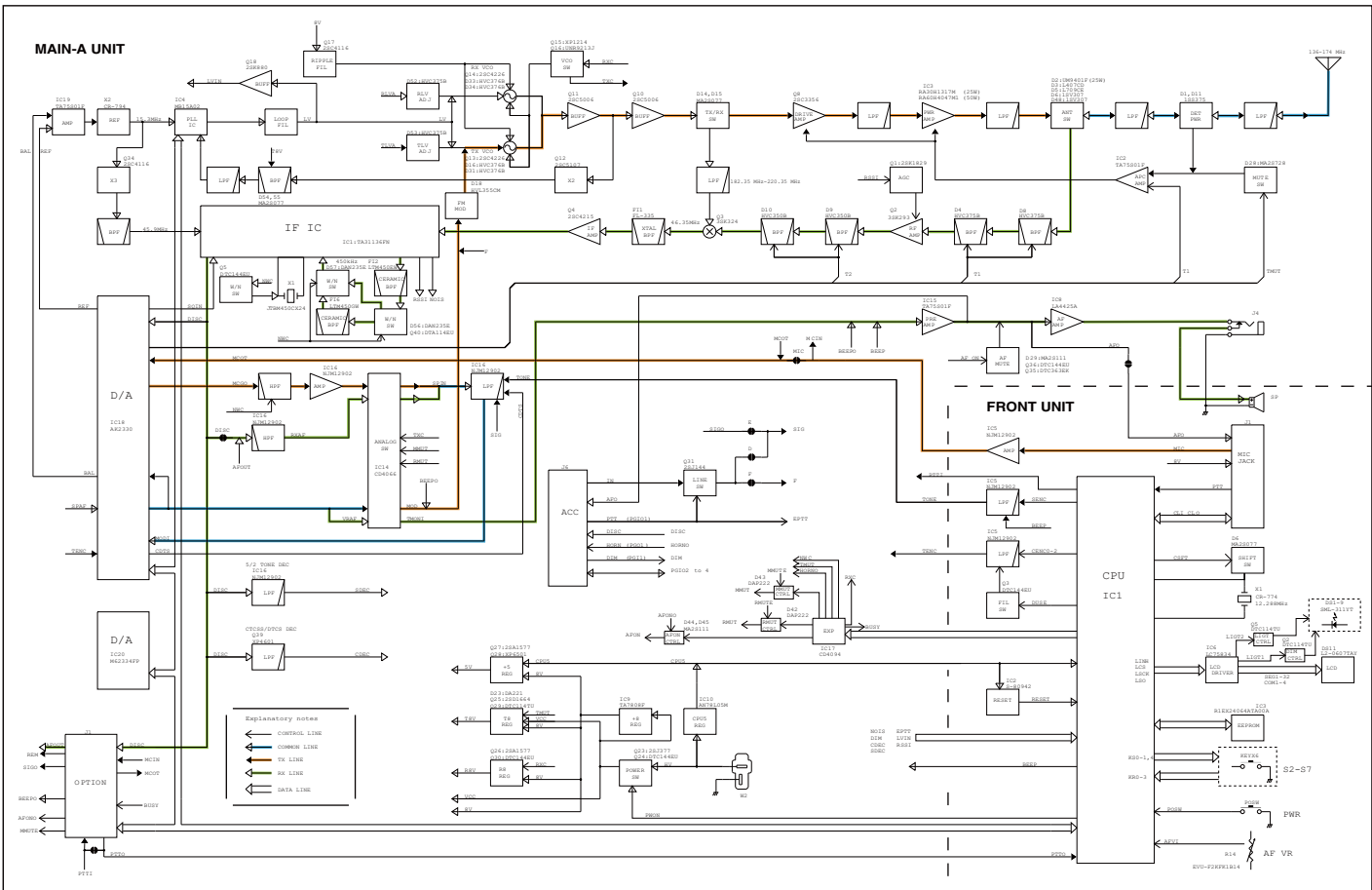

## SECTION 12 VOLTAGE DIAGRAM

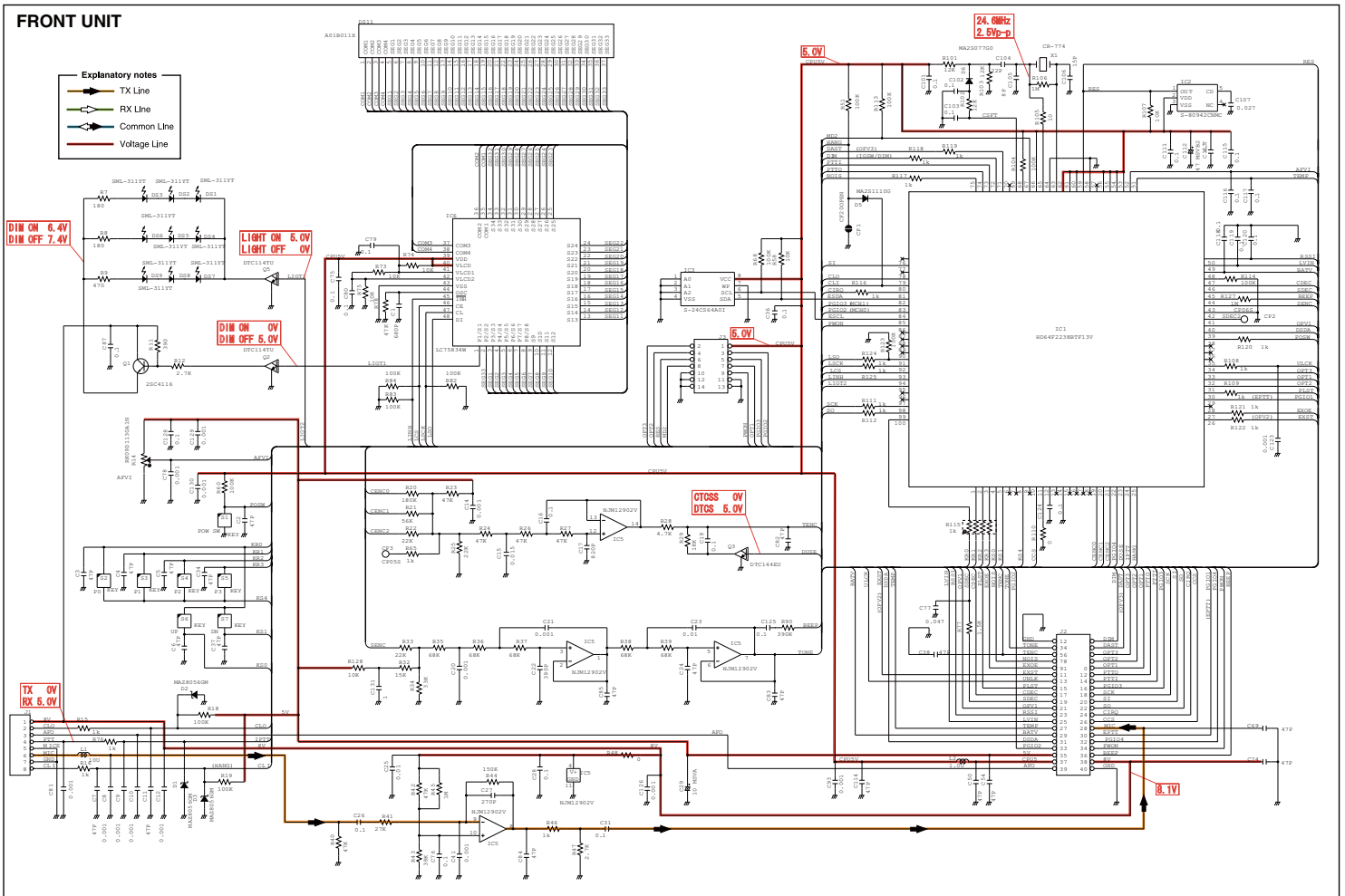

\*; Refer to "PARTS LIST."

MAIN UNIT (1/2)

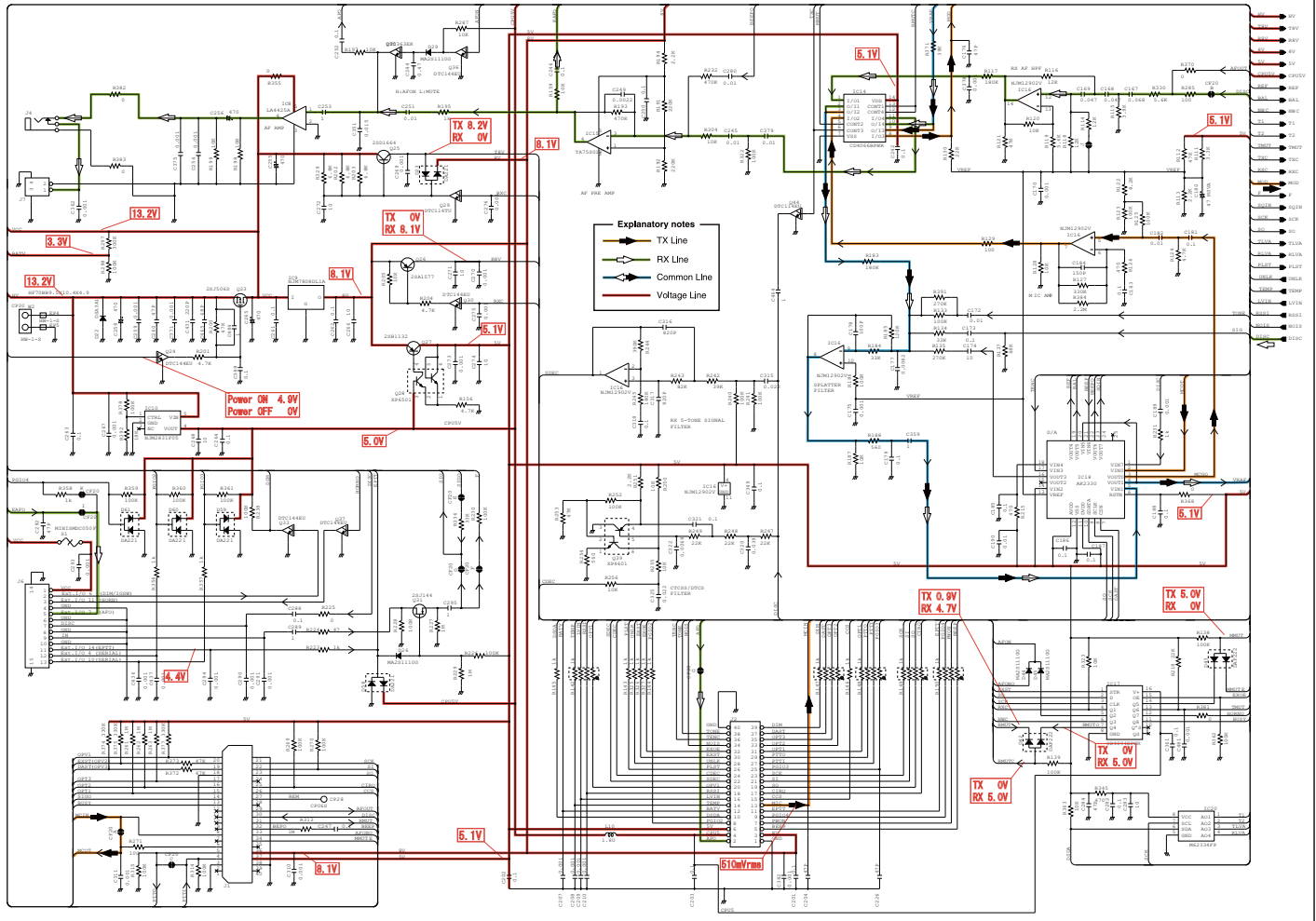





## Icom Inc.

1-1-32, Kamiminami, Hirano-ku, Osaka 547-0003, Japan  
Phone : +81 (06) 6793 5302  
Fax : +81 (06) 6793 0013  
URL : <http://www.icom.co.jp/world/index.html>

### Icom America Inc.

<Corporate Headquarters>  
2380 116th Avenue N.E., Bellevue, WA 98004, U.S.A.  
Phone : +1 (425) 454-8155 Fax : +1 (425) 454-1509  
URL : <http://www.icomamerica.com>  
E-mail : [sales@icomamerica.com](mailto:sales@icomamerica.com)  
<Customer Service>  
Phone : +1 (425) 454-7619

### Icom Canada

Glenwood Centre #150-6165  
Highway 17 Delta, B.C., V4K 5B8, Canada  
Phone : +1 (604) 952-4266 Fax : +1 (604) 952-0090  
URL : <http://www.icomcanada.com>  
E-mail : [info@icomcanada.com](mailto:info@icomcanada.com)

### Icom (Australia) Pty. Ltd.

Unit 1 / 103 Garden Road, Clayton VIC 3168 Australia  
Phone : +61 (03) 9549-7500 Fax : +61 (03) 9549-7505  
URL : <http://www.icom.net.au>  
E-mail : [sales@icom.net.au](mailto:sales@icom.net.au)

### Icom New Zealand

146A Harris Road, East Tamaki,  
Auckland, New Zealand  
Phone : +64 (09) 274 4062 Fax : +64 (09) 274 4708  
URL : <http://www.icom.co.nz>  
E-mail : [inquiries@icom.co.nz](mailto:inquiries@icom.co.nz)

### Beijing Icom Ltd.

10C07, Long silver Mansion, No.88, Yong Ding  
Road, Haidian District, Beijing, 100039, China  
Phone : +86 (010) 5889 5391/5392/5393  
Fax : +86 (010) 5889 5395  
E-mail : [bjicom@bjicom.com](mailto:bjicom@bjicom.com)  
URL : <http://www.bjicom.com>

### Icom (Europe) GmbH

Communication Equipment  
Auf der Krautweide 24  
65812 Bad Soden am Taunus, Germany  
Phone : +49 (6196) 76685-0 Fax : +49 (6196) 76685-50  
URL : <http://www.icomeurope.com>  
E-mail : [info@icomeurope.com](mailto:info@icomeurope.com)

### Icom Spain S.L.

Ctra. Rubí, No. 88 Bajos A 08174, Sant Cugat del Valles, Barcelona, Spain  
Phone : +34 (93) 590 26 70 Fax : +34 (93) 589 04 46  
URL : <http://www.icomspain.com>  
E-mail : [icom@icomspain.com](mailto:icom@icomspain.com)

### Icom (UK) Ltd.

Unit 9, Sea St., Herne Bay, Kent, CT6 8LD, U.K.  
Phone : +44 (01227) 741741 Fax : +44 (01227) 741742  
URL : <http://www.icomuk.co.uk>  
E-mail : [info@icomuk.co.uk](mailto:info@icomuk.co.uk)

### Icom France s.a.s.

Zac de la Plaine  
1 Rue Brindejonc des Moulinais BP 5804  
31505 Toulouse Cedex, France  
Phone : +33 (5) 61 36 03 03 Fax : +33 (5) 61 36 03 00  
URL : <http://www.icom-france.com>  
E-mail : [icom@icom-france.com](mailto:icom@icom-france.com)

### Asia Icom Inc.

6F No.68, Sec. 1 Cheng-Teh Road, Taipei, Taiwan, R.O.C.  
Phone : +886 (02) 2559 1899 Fax : +886 (02) 2559 1874  
URL : <http://www.asia-icom.com>  
E-mail : [sales@asia-icom.com](mailto:sales@asia-icom.com)

### Icom Polska

81-850 Sopot, ul. 3 Maja 54, Poland  
Phone : +48 (58) 550 7135 Fax : +48 (58) 551 0484  
E-mail : [icompolska@icompolska.com.pl](mailto:icompolska@icompolska.com.pl)

**Count on us!**



---

---

---

---

---

**Icom Inc.**

1-1-32, Kamiminami, Hirano-ku, Osaka 547-0003, Japan

S-14524XZ-C1  
© 2009 Icom Inc.