

# Operating Instructions

## Tankvision LMS NXA86

### LNG Stratification Detection

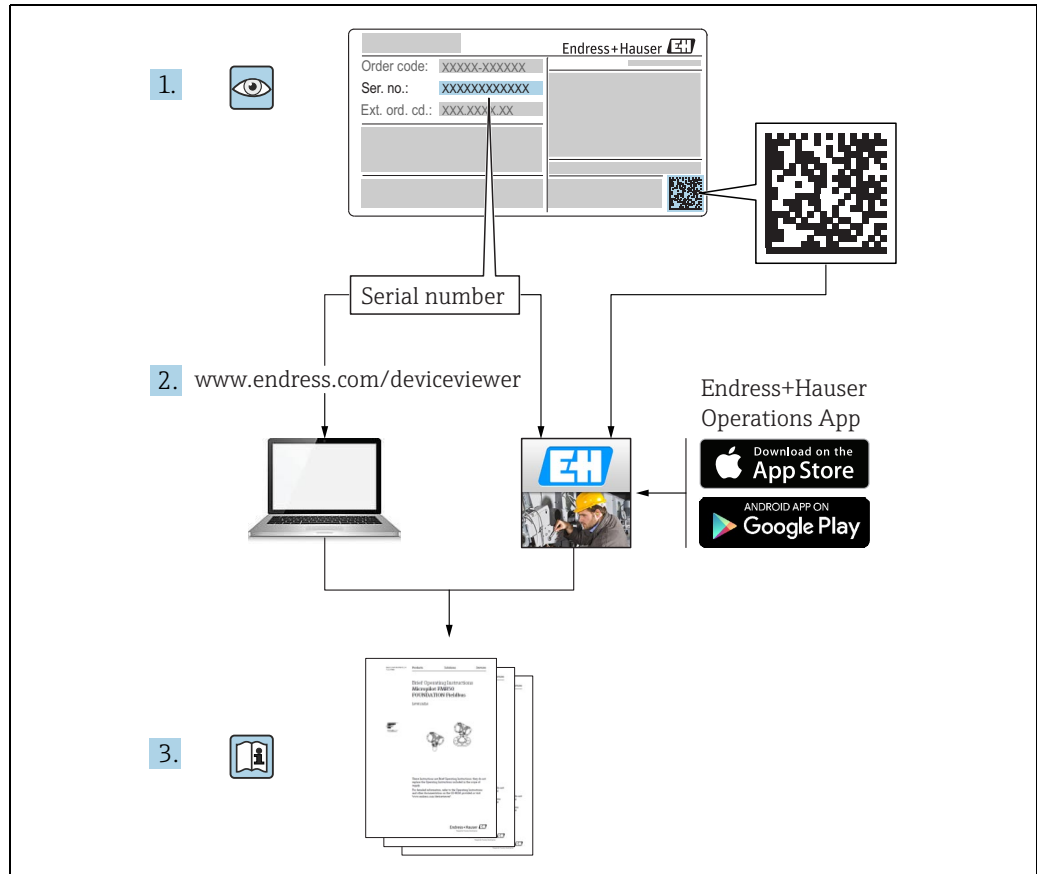



A0023555

## Table of Contents

<b>1</b>	<b>Document information</b>	<b>4</b>
1.1	Target audience for this manual	4
1.2	Version history	4
1.3	Document function	4
1.4	Documentation	5
<b>2</b>	<b>Identification</b>	<b>6</b>
2.1	Product identification	6
2.2	Nameplate	6
2.3	Order code and device version	7
2.4	Device documentation	7
2.5	Registered trademarks	7
<b>3</b>	<b>Basic safety instructions</b>	<b>8</b>
3.1	Requirements for the personnel	8
3.2	IT security	8
3.3	Designated use	8
3.4	Workplace safety	9
3.5	Operational safety	9
3.6	Product safety	9
<b>4</b>	<b>Stratification Detection</b>	<b>10</b>
4.1	What is stratification?	10
4.2	Consequences of stratification	10
4.3	Identifying stratification	10
4.4	Examining Strata	11
	<b>Index</b>	<b>12</b>

# 1 Document information

## 1.1 Target audience for this manual

This manual should support during the installation and maintenance of Tankvision LMS NXA86.

Beside basic PC operating knowledge no special training is needed to perform the Tank Gauging System operations. Nevertheless it is recommended receiving a training on the system by Endress+Hauser.





## 1.2 Version history

Document version	Valid for SW version	Changes to the previous version
BA01704G/00/EN/01.17	18.0.2 and 18.0.3	Initial version
BA01704G/00/EN/02.18	18.1.1	Compatibility with Windows 10 and Windows Server 2016





## 1.3 Document function

### 1.3.1 Used symbols



#### Safety symbols

Symbol	Meaning
 A0011189-EN	<b>DANGER!</b> This symbol alerts you to a dangerous situation. Failure to avoid this situation will result in serious or fatal injury.
 A0011190-EN	<b>WARNING!</b> This symbol alerts you to a dangerous situation. Failure to avoid this situation can result in serious or fatal injury.
 A0011191-EN	<b>CAUTION!</b> This symbol alerts you to a dangerous situation. Failure to avoid this situation can result in minor or medium injury.
 A0011192-EN	<b>NOTICE!</b> This symbol contains information on procedures and other facts which do not result in personal injury.



#### Electrical symbols

Symbol	Meaning
 A0011197	<b>Direct current</b> A terminal to which DC voltage is applied or through which direct current flows.
 A0011198	<b>Alternating current</b> A terminal to which alternating voltage is applied or through which alternating current flows.
 A0011200	<b>Ground connection</b> A grounded terminal which, as far as the operator is concerned, is grounded via a grounding system.
 A0011199	<b>Protective ground connection</b> A terminal which must be connected to ground prior to establishing any other connections.

### Symbols for certain types of information

Symbol	Meaning
 A0011193	<b>Tip</b> Indicates additional information.
 A0011195	<b>Reference to page</b> Refers to the corresponding page number.
1. , 2. , 3. ...	Series of steps
 A0018373	Result of a sequence of actions

### Symbols in graphics

Symbol	Meaning
1, 2, 3 ...	Item numbers
1. , 2. , 3. ...	Series of steps
A, B, C ...	Views
 A0011187	<b>Hazardous area</b> Indicates a hazardous area.
 A0011188	<b>Indicates a non-hazardous location</b> Safe area (non-hazardous area)

## 1.4 Documentation

### 1.4.1 Operating instructions

Document number	Instrument	Type of Document
BA00390G/00	Tankvision Professional & LMS	System Configuration
BA00391G/00	Tankvision Professional & LMS	Data Communications Controller
BA00393G/00	Tankvision Professional & LMS	Maintenance
BA01293G/00	Tankvision Professional & LMS	OPC Tank Data Server
BA01294G/00	Tankvision Professional & LMS	OPC TG Client Configuration
BA01654G/00	Tankvision Professional & LMS	System Monitor
BA01700G/00	Tankvision LMS	Installation
BA01701G/00	Tankvision LMS	System Operation
BA01702G/00	Tankvision LMS	Rollover Prediction in LNG storage tanks
BA01703G/00	Tankvision LMS	Skin Temperature
BA01704G/00	Tankvision LMS	LNG Stratification Detection

## 2 Identification

### 2.1 Product identification

The following options are available for identification of the software:

- Nameplate specifications
- Order code with breakdown of the software features on the delivery note
- Enter serial numbers from nameplates in W@M Device Viewer  
([www.endress.com/deviceviewer](http://www.endress.com/deviceviewer)): All information about the software is displayed.

For an overview of the technical documentation provided, enter the serial number from the nameplates in the W@M Device Viewer ([www.endress.com/deviceviewer](http://www.endress.com/deviceviewer)).

### 2.2 Nameplate

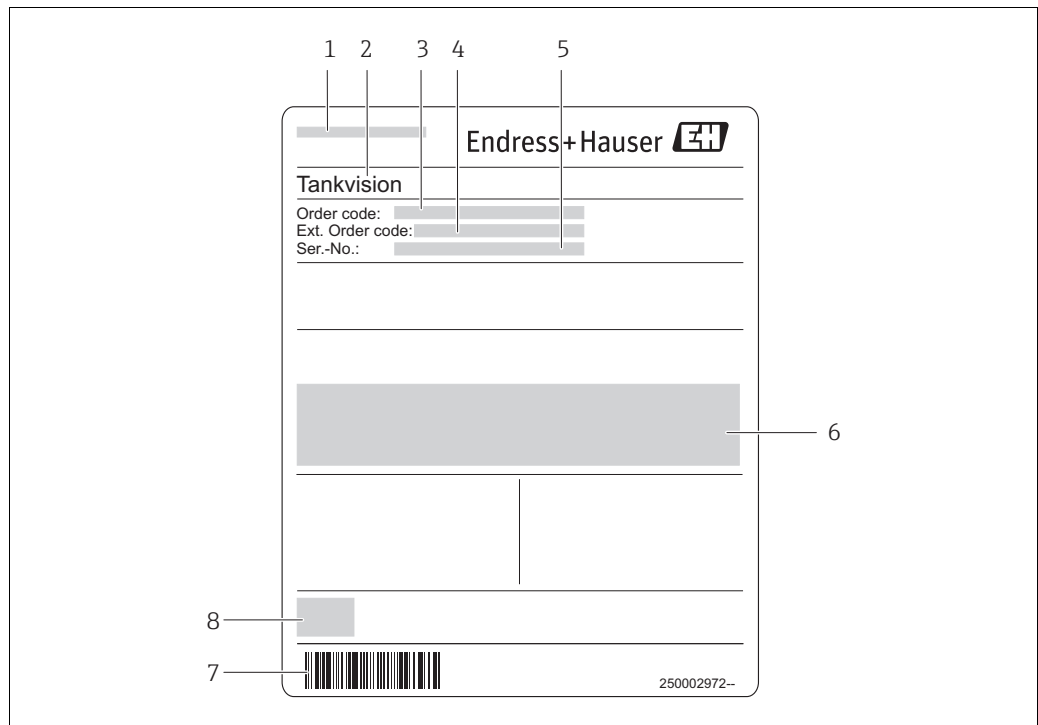

- 1 Address of manufacturer
- 2 Device name
- 3 Order code
- 4 Extended order code (Ext. ord. cd.)
- 5 Serial number (Ser. no.)
- 6 Certificate and approval relevant data
- 7 Barcode
- 8 CE mark

## 2.3 Order code and device version

-  To find out the version of your software, enter the order code indicated on the nameplate in the search screen at the following address:  
[www.products.endress.com/order-ident](http://www.products.endress.com/order-ident)

## 2.4 Device documentation

The information required to retrieve the documentation can be found on the nameplate of the device.

-  Technical documentation can also be downloaded from the Download Area of the Endress+Hauser web site: [www.endress.com](http://www.endress.com) → Download. However this technical documentation applies to a particular instrument family and is not assigned to a specific device.

### 2.4.1 W@M Device Viewer

1. Launch the W@M Device Viewer: [www.endress.com/deviceviewer](http://www.endress.com/deviceviewer)
2. Enter the serial number (Ser. no.) of the device: see nameplate.  
↳ All the associated documentation is displayed.

### 2.4.2 Endress+Hauser Operations App

-  The *Endress+Hauser Operations App* is available both for android smart phones (Google Play Store) and for iPhones and iPads (App Store).

Via the serial number:

1. Launch the *Endress+Hauser Operations App*.
2. Enter the serial number (Ser. no.) of the device: see nameplate.  
↳ All the associated documentation is displayed.

## 2.5 Registered trademarks

Microsoft<sup>®</sup>, Windows<sup>®</sup> and Internet Explorer<sup>®</sup>  
Registered trademarks of the Microsoft Corporation

Modbus<sup>®</sup>  
Registered trademark of the Modbus-IDA, Hopkinton, MA, USA

Java<sup>®</sup>  
Registered trademark of Sun Microsystems, Inc.

Mozilla<sup>®</sup> Firefox<sup>®</sup>  
Registered trademark of the Mozilla Foundation

Android<sup>®</sup> and Google Play<sup>®</sup> are registered trademarks of Google Inc.

iPhone<sup>®</sup> and iPad<sup>®</sup> are trademarks of Apple<sup>®</sup> Inc., registered in the U.S. and other countries.

## 3 Basic safety instructions

### 3.1 Requirements for the personnel

The personnel for installation, commissioning, diagnostics and maintenance must fulfill the following requirements:

- Trained, qualified specialists: must have a relevant qualification for this specific function and task
- Are authorized by the plant owner/operator
- Are familiar with federal/national regulations
- Before beginning work, the specialist staff must have read and understood the instructions in the Operating Instructions and supplementary documentation as well as in the certificates (depending on the application)
- Following instructions and basic conditions

The operating personnel must fulfill the following requirements:

- Being instructed and authorized according to the requirements of the task by the facility's owner operator
- Following the instructions in these Operating Instructions

### 3.2 IT security

We only provide a warranty if the device is installed and used as described in the Operating Instructions. The device is equipped with security mechanisms to protect it against any inadvertent changes to the device settings.

IT security measures in line with operators' security standards and designed to provide additional protection for the device and device data transfer must be implemented by the operators themselves.

### 3.3 Designated use

#### 3.3.1 Application

Tankvision LMS is a total LNG Tank Storage and Management solution for Peak Shaving, Receiving and Production LNG facilities. The LMS system has been designed to interface to all instruments commonly found on LNG storage tanks, and to collect and present the instrument data through a range of intuitive graphical user interfaces. A typical LNG Tank will have a wide range of measurement instruments to measure Liquid Level, Liquid Density, Liquid and Vapour Temperature, Liquid and Vapour Pressure, Skin Temperature and much more.

Typically each tank would be fitted with an LTD gauge, two further level gauges configured as a Primary and Secondary, and an Alarm Gauge. The LTD gauge is a servo operated unit mounted on the tank roof. The purpose of the LTD gauge is to take accurate profiles of temperature and density throughout the liquid, and whilst not profiling provide continuous liquid level, temperature and density measurement. The Primary and Secondary gauges can be either servo and or radar operated units also mounted on the tank roof. The purpose of these gauges is to provide continuous liquid level measurement, and average liquid temperature measurement. They provide redundancy on the measurement of level and temperature. The average liquid temperature is derived from a multi point temperature sensor device. The alarm gauge is often a servo or radar based gauge configured to provide volt free contact alarm status to an independent system.

An LMS system can operate in a simple standalone configuration or as a fully redundant system where security and integrity are of paramount importance. The LMS system has a



flexible and scalable architecture allowing it to be tailored to a number of different applications easily.

### 3.4 Workplace safety

For work on and with the device:

- Wear the required personal protective equipment according to federal/national regulations.
- Switch off the supply voltage before connecting the device.

### 3.5 Operational safety

Risk of injury!

- Operate the device in proper technical condition and fail-safe condition only.
- The operator is responsible for interference-free operation of the device.

#### Conversions to the device

Unauthorized modifications to the device are not permitted and can lead to unforeseeable dangers

- If, despite this, modifications are required, consult with Endress+Hauser.

#### Repair

To ensure continued operational safety and reliability,

- Carry out repairs on the device only if they are expressly permitted.
- Observe federal/national regulations pertaining to repair of an electrical device.
- Use original spare parts and accessories from Endress+Hauser only.

### 3.6 Product safety

The device is designed to meet state-of-the-art safety requirements, has been tested and left the factory in a condition in which it is safe to operate. The device complies with the applicable standards and regulations as listed in the EC declaration of conformity and thus complies with the statutory requirements of the EG directives. Endress+Hauser confirms the successful testing of the device by affixing to it the CE mark.

## 4 Stratification Detection

### 4.1 What is stratification?

Everyone has an intuitive idea about what stratification is; the name of the phenomena itself suggests horizontal layers of material within a body, however describing it in terms a computer can understand is more challenging.

In general terms a stratified body exhibits localised differences in state. In tank gauging we are forced to identify those differences in state in terms of temperature and density, as we are limited to these pieces of localized data by the instruments provided. We are also forced to assume that the column of material that is sampled by the gauge is indicative of all material at that level; this is not always a safe assumption, particularly in LNG tanks.

### 4.2 Consequences of stratification

In LNG tanks stratification is of importance as it is one of the key processes that leads to rollover. The appearance of strata indicates that a barrier to the free movement of fluids within the body has formed and it is this that can prevent heat entering the body from leaving it through evaporation at surface of the liquid. Obviously, if heat can't leave the body at the same rate as it enters it, energy is built up; it is this energy that is released catastrophically during rollover.

### 4.3 Identifying stratification

If we could measure the temperature and density of the tank contents with infinite accuracy, it would be easy to identify strata as each consecutive point within a stratum would have exactly the same temperature and density. Unfortunately, we equip our LNG storage tanks with real world devices that have a limited accuracy. The readings of density and temperature, collectively known as a profile, produced by the gauge will generally deviate from the actual density, which we can never actually know, by a random amount. The figures (a) and (b) below show plots of two different profiles, the horizontal axis represents density and the vertical axis temperature. The data has been transposed by the mean and scaled by the range for each set of data.

#### (a) Homogenous

The figure below shows a profile from a homogenous tank. Notice how the profile points form a single circular cluster centered on the origin.

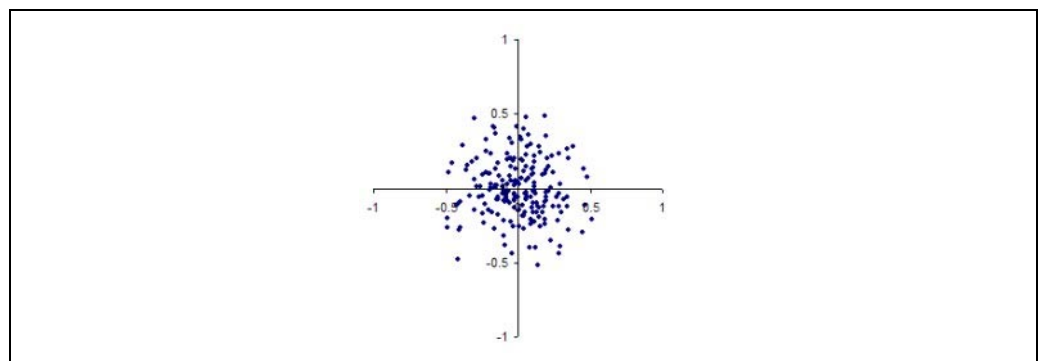

BA0xxxxGEN\_Stratification\_Detection\_001

#### (b) Strata

The figure below shows a profile from a tank with two strata. The points are arranged in 2 clusters, as 90 % of the points are in one of the clusters, the mean is pulled over toward that cluster. The 10 % of the points in the smaller cluster are colder and denser than the bulk of the points. The few points between the two clusters indicate that the interface between the two strata is indistinct.

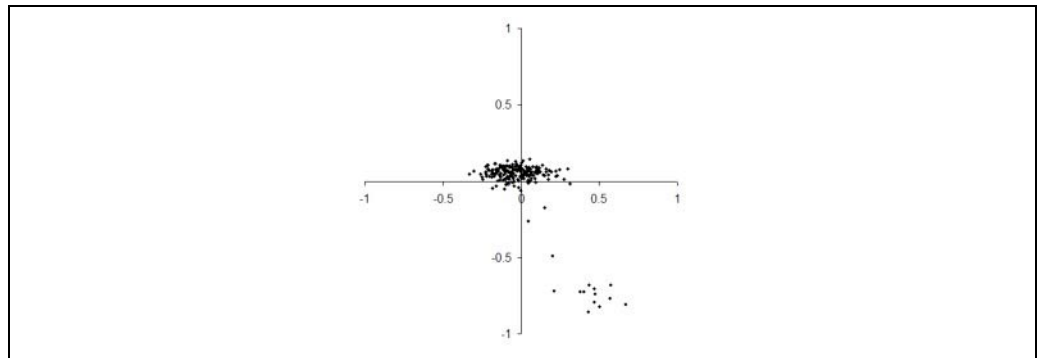

BA0xxxxGEN\_Stratification\_Detection\_002

When examining profiles such as the ones illustrated, the computer examines consecutive readings (by level) and given the accuracy of the gauge will group those that differ by an amount less than can be explained by gauge inaccuracies into one stratum. Average density and temperature can then be calculated for the strata discovered in the above process.

### 4.4 Examining Strata

Once the points in the profile data have been assigned to a stratum, by sorting them by level you can calculate the position, depth and the mean temperature and density. The following figure shows such a display, the graph allows you to correlate the computer's analysis of the profile data back to the original data. The table of data shows the calculated details of the strata.

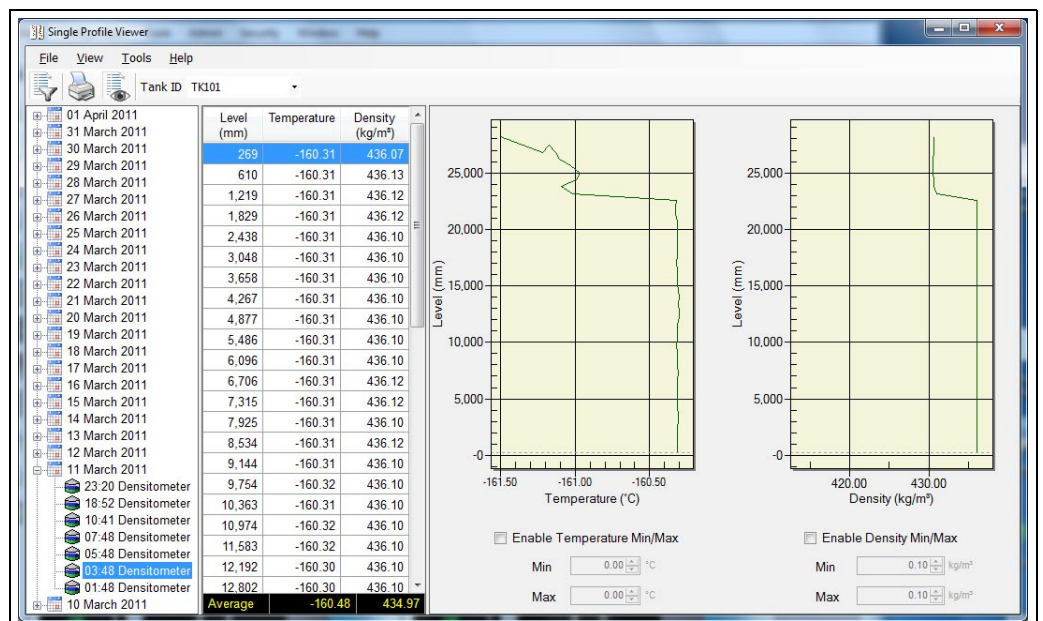

BA0xxxxGEN\_Stratification\_Detection\_003

## Index

<b>C</b>	
Consequences of stratification .....	10
<b>D</b>	
Designated Use .....	8
Device Version .....	7
<b>E</b>	
Examining Strata .....	11
<b>I</b>	
Icons .....	4
Identifying stratification .....	10
<b>O</b>	
Order Code .....	7
<b>S</b>	
Safety icons .....	4
Stratification .....	10
Stratification Detection .....	10
Symbols .....	4
<b>T</b>	
Trademarks .....	7





71392430

[www.addresses.endress.com](http://www.addresses.endress.com)

---