

Documentation

KL1xxx

Digital input terminals, 24 V DC

Version: 1.0.0
Date: 2020-05-08

BECKHOFF

Table of contents

1 Foreword	5
1.1 Notes on the documentation.....	5
1.2 Safety instructions	6
1.3 Documentation issue status	7
2 Product overview.....	8
2.1 KL1xxx terminal overview	8
2.2 KL1002, KL1012 - Introduction.....	9
2.2.1 KL1002, KL1012 – Technical data.....	10
2.2.2 KL1002 - LEDs and connection	11
2.2.3 KL1012 - LEDs and connection	12
2.3 KL1104, KL1114 - Introduction.....	13
2.3.1 KL1104, KL1114 – Technical data.....	14
2.3.2 KL1104, KL1114 - LEDs and connection.....	15
2.4 KL1402, KL1412 - Introduction.....	16
2.4.1 KL1402, KL1412 – Technical data.....	17
2.4.2 KL1402, KL1412 - LEDs and connection.....	18
2.5 KL1404, KL1414, KL1434 - Introduction	19
2.5.1 KL1404, KL1414, KL1434 - Technical data	21
2.5.2 KL1404, KL1414 - LEDs and connection.....	22
2.5.3 KL1434 - LEDs and connection	23
2.6 KL1408, KL1418, KL1488, KL1498 - Introduction	24
2.6.1 KL1408, KL1418, KL1488, KL1498 – Technical data.....	26
2.6.2 KL1408, KL1418 - LEDs and connection.....	27
2.6.3 KL1488, KL1498 - LEDs and connection.....	28
2.7 KL1862, KL1862-0010, KL1872 - Introduction	29
2.7.1 KL1862, KL1862-0010, KL1872 – Technical data	30
2.7.2 KL1862, KL1872 - LEDs and connection.....	31
3 Mounting and wiring.....	32
3.1 Installation on mounting rails	32
3.2 Installation instructions for enhanced mechanical load capacity	35
3.3 Connection	35
3.3.1 Connection system	35
3.3.2 Wiring.....	38
3.3.3 Shielding	39
3.4 ATEX - Special conditions (standard temperature range)	40
3.5 ATEX - Special conditions (extended temperature range)	41
3.6 Continulative documentation about explosion protection	42
4 KS2000 Configuration software	43
4.1 KS2000 - Introduction.....	43
5 Access from the user program	45
5.1 Examples of Register Communication	45
5.1.1 Example 1: reading the firmware version from Register 9.....	45
5.1.2 Example 2: Writing to an user register.....	45

6 TwinCAT	49
6.1 Programming	50
7 Appendix	51
7.1 Support and Service	51

1 Foreword

1.1 Notes on the documentation

Intended audience

This description is only intended for the use of trained specialists in control and automation engineering who are familiar with the applicable national standards.

It is essential that the documentation and the following notes and explanations are followed when installing and commissioning these components.

It is the duty of the technical personnel to use the documentation published at the respective time of each installation and commissioning.

The responsible staff must ensure that the application or use of the products described satisfy all the requirements for safety, including all the relevant laws, regulations, guidelines and standards.

Disclaimer

The documentation has been prepared with care. The products described are, however, constantly under development.

We reserve the right to revise and change the documentation at any time and without prior announcement.

No claims for the modification of products that have already been supplied may be made on the basis of the data, diagrams and descriptions in this documentation.

Trademarks

Beckhoff®, TwinCAT®, EtherCAT®, EtherCAT G®, EtherCAT G10®, EtherCAT P®, Safety over EtherCAT®, TwinSAFE®, XFC®, XTS® and XPlanar® are registered trademarks of and licensed by Beckhoff Automation GmbH. Other designations used in this publication may be trademarks whose use by third parties for their own purposes could violate the rights of the owners.

Patent Pending

The EtherCAT Technology is covered, including but not limited to the following patent applications and patents: EP1590927, EP1789857, EP1456722, EP2137893, DE102015105702 with corresponding applications or registrations in various other countries.

The logo for EtherCAT, featuring the word "EtherCAT" in a bold, black, sans-serif font. A red arrow points from the top of the "A" towards the right, ending above the "T". A registered trademark symbol (®) is located to the right of the "T".

EtherCAT® is registered trademark and patented technology, licensed by Beckhoff Automation GmbH, Germany.

Copyright

© Beckhoff Automation GmbH & Co. KG, Germany.

The reproduction, distribution and utilization of this document as well as the communication of its contents to others without express authorization are prohibited.

Offenders will be held liable for the payment of damages. All rights reserved in the event of the grant of a patent, utility model or design.

1.2 Safety instructions

Safety regulations

Please note the following safety instructions and explanations!
Product-specific safety instructions can be found on following pages or in the areas mounting, wiring, commissioning etc.

Exclusion of liability

All the components are supplied in particular hardware and software configurations appropriate for the application. Modifications to hardware or software configurations other than those described in the documentation are not permitted, and nullify the liability of Beckhoff Automation GmbH & Co. KG.

Personnel qualification

This description is only intended for trained specialists in control, automation and drive engineering who are familiar with the applicable national standards.

Description of instructions

In this documentation the following instructions are used.
These instructions must be read carefully and followed without fail!

DANGER

Serious risk of injury!

Failure to follow this safety instruction directly endangers the life and health of persons.

WARNING

Risk of injury!

Failure to follow this safety instruction endangers the life and health of persons.

CAUTION

Personal injuries!

Failure to follow this safety instruction can lead to injuries to persons.

NOTE

Damage to environment/equipment or data loss

Failure to follow this instruction can lead to environmental damage, equipment damage or data loss.



Tip or pointer

This symbol indicates information that contributes to better understanding.

1.3 Documentation issue status

Version	Comment
1.0.0	<ul style="list-style-type: none"> • Migration • Structure update • Technical data updated • Installation instructions for enhanced mechanical load capacity added • Revision status updated

Firmware and hardware versions

Documentation Version	KL1002		KL1012		KL1104		KL1114	
	Firmware	Hardware	Firmware	Hardware	Firmware	Hardware	Firmware	Hardware
1.0.0	-	05	-	05	-	05	-	05

Documentation Version	KL1402		KL1412		KL1404		KL1414	
	Firmware	Hardware	Firmware	Hardware	Firmware	Hardware	Firmware	Hardware
1.0.0	-	00	-	00	-	04	-	04

Documentation Version	KL1434		KL1408		KL1418		KL1488	
	Firmware	Hardware	Firmware	Hardware	Firmware	Hardware	Firmware	Hardware
1.0.0	-	02	-	08	-	07	-	02

Documentation Version	KL1498		KL1862		1862-0010		KL1872	
	Firmware	Hardware	Firmware	Hardware	Firmware	Hardware	Firmware	Hardware
1.0.0	-	02	-	01	-	00	-	00

The K-bus firmware and hardware version (delivery state) are indicated by the serial number printed at the side of the terminal.

Syntax of the serial number

Structure of the serial number: WW YY FF HH

- WW - week of production (calendar week)
- YY - year of production
- FF - K-bus firmware version
- HH - hardware version

Example with ser. no.: 49 05 1B 03:

- 49 - week of production 49
- 05 - year of production 2005
- 1B - firmware version 1B
- 03 - hardware version 03

2 Product overview

2.1 KL1xxx terminal overview

Digital input terminals

Terminal	Number of inputs	Nominal voltage	Filter	Comment
KL1002 [▶ 9]	2	24 V _{DC}	3 ms	
KL1012 [▶ 9]	2	24 V _{DC}	0.2 ms	
KL1104 [▶ 13]	4	24 V _{DC}	3 ms	
KL1114 [▶ 13]	4	24 V _{DC}	0.2 ms	
KL1402 [▶ 16]	2	24 V _{DC}	3 ms	
KL1412 [▶ 16]	2	24 V _{DC}	0.2 ms	
KL1404 [▶ 19]	4	24 V _{DC}	3 ms	
KL1408 [▶ 24]	8	24 V _{DC}	3 ms	
KL1414 [▶ 19]	4	24 V _{DC}	0.2 ms	
KL1418 [▶ 24]	8	24 V _{DC}	0.2 ms	
KL1434 [▶ 19]	4	24 V _{DC}	0.2 ms	
KL1488 [▶ 24]	8	24 V _{DC}	3 ms	
KL1498 [▶ 24]	8	24 V _{DC}	0.2 ms	
KL1862-0000 [▶ 29]	16	24 V _{DC}	3 ms	
KL1862-0010 [▶ 29]	16	24 V _{DC}	3 ms	
KL1872 [▶ 29]	16	24 V _{DC}	0.2 ms	

2.2 KL1002, KL1012 - Introduction

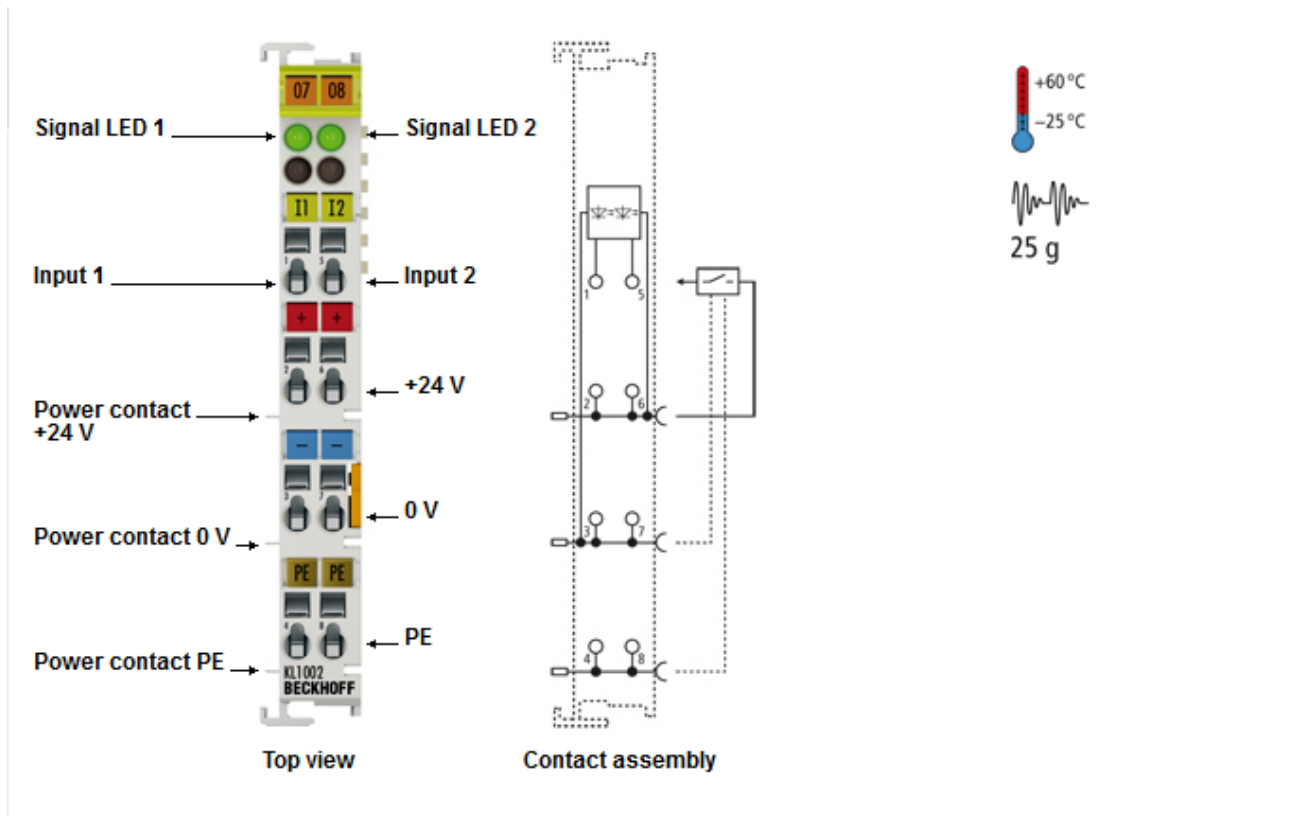

Fig. 1: KL1002

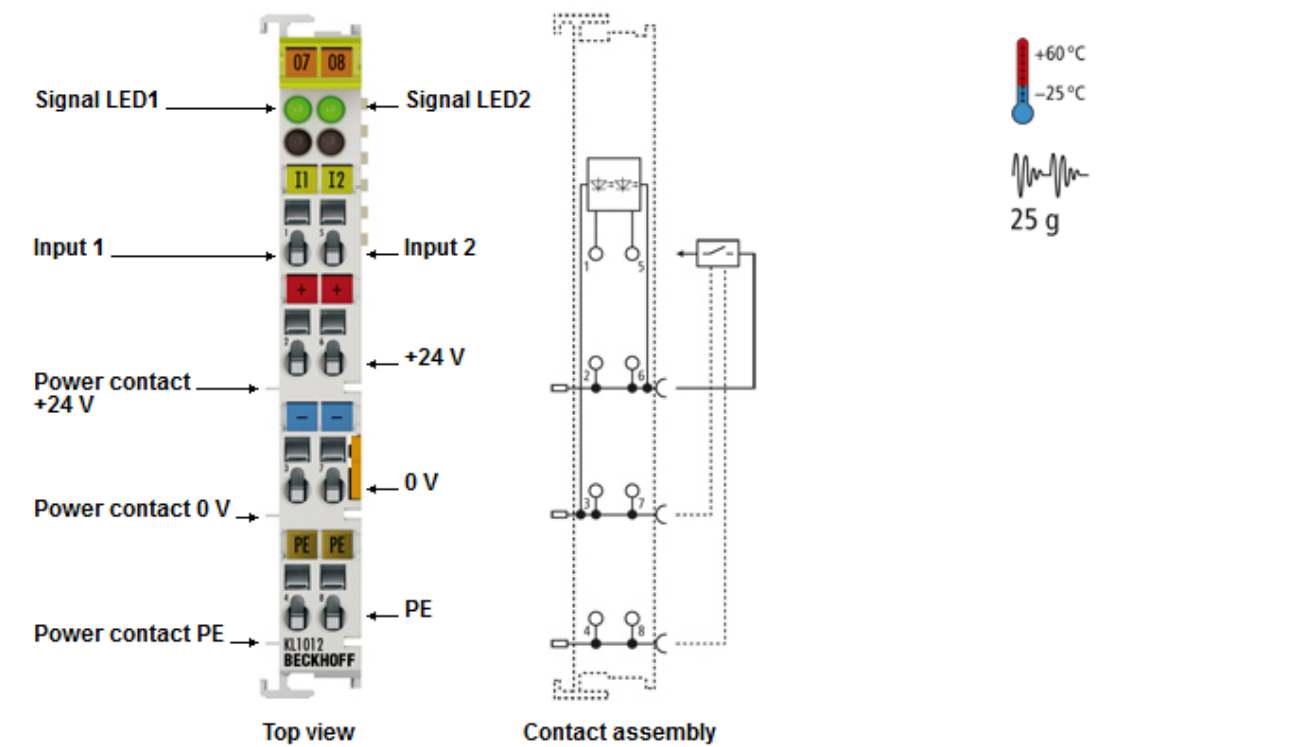

Fig. 2: KL1012

Two-channel, digital input terminals, 24 V_{DC}

The KL1002 and KL1012 digital input terminals acquire the binary control signals from the process level and transmit them, in an electrically isolated form, to the higher-level automation unit. The KL1002 and KL1012 versions have input filters of different speeds. The Bus Terminals contain two channels that indicate their signal state by means of light emitting diodes.

2.2.1 KL1002, KL1012 – Technical data

Technical data	KL1002, KS1002	KL1012, KS1012
Connection technology	4-wire	
Specification	EN 61131-2, type 1/3	
Number of counters	2	
Nominal voltage	24 V _{DC} (-15 %/+20 %)	
Signal voltage '0'	-3 V to 5 V (EN 61131-2, type 1)	
Signal voltage '1'	15 V to 30 V (EN 61131-2, type 1)	
Input filter	3 ms	0.2 ms
Input current	typically 5 mA (EN 61131-2, type 1)	
Current consumption from K-bus	typically 3 mA	
Electrical isolation	500 V (K-bus / field voltage)	
Bit width in process image	2 input bits	
Configuration	no address or configuration settings required	
Weight approx.	50 g	
Permissible ambient temperature during operation	-25°C ... +60°C (extended temperature range)	
Permissible ambient temperature during storage	-40°C ... +85°C	
Permissible relative humidity	95 %, no condensation	
Vibration / shock resistance	according to EN 60068-2-6 / EN 60068-2-27, refer also to Installation instructions for enhanced mechanical load capacity [▶ 35]	
EMC immunity / emission	conforms to EN 61000-6-2 / EN 61000-6-4	
Installation position	variable	
Protection class	IP20	
Pluggable wiring	for all KSxxxx terminals	
Approvals	CE, cULus, ATEX [▶ 41], GL	

2.2.2 KL1002 - LEDs and connection

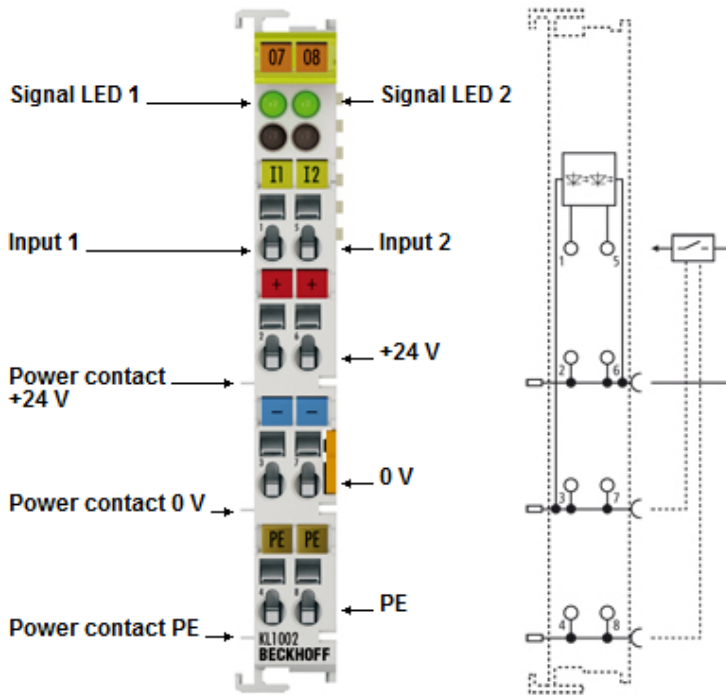

Fig. 3: KL1002

KL1002 - LEDs

LED	Color	Meaning	
Signal LEDs 1 - 2	green	off	Signal voltage "0" (-3 V ... 5 V)
		on	Signal voltage "1" (15 V ... 30 V)

KL1002 - Connection

Terminal point		Description
Name	No.	
Input 1	1	Input 1
+24 V	2	Sensor supply for input 1 (internally connected to terminal point 6 and positive power contact)
0 V	3	Ground for input 1 (internally connected to terminal point 7 and negative power contact)
PE	4	PE (internally connected to terminal point 8)
Input 2	5	Input 2
+24 V	6	Sensor supply for input 2 (internally connected to terminal point 2 and positive power contact)
0 V	7	Ground for input 2 (internally connected to terminal point 3 and negative power contact)
PE	8	PE (internally connected to terminal point 4)

2.2.3 KL1012 - LEDs and connection

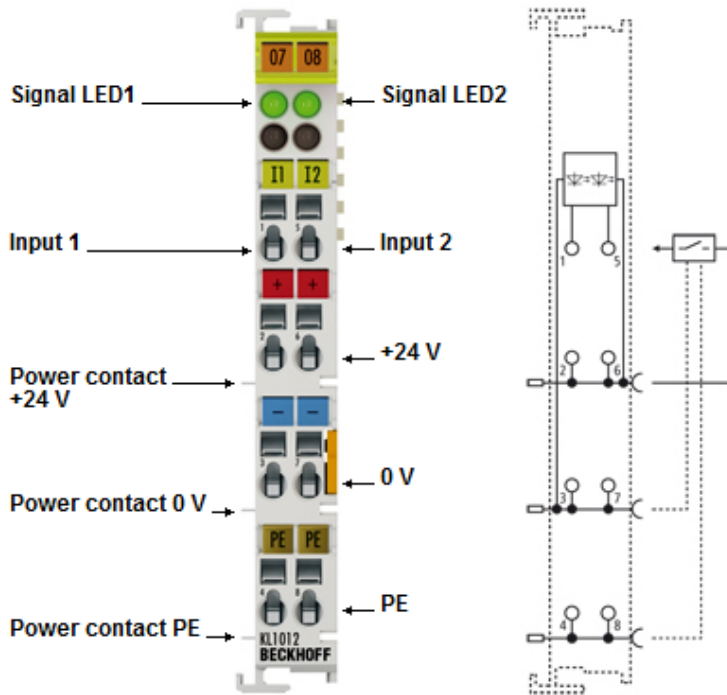

Fig. 4: KL1012

KL1012 - LEDs

LED	Color	Meaning	
Signal LEDs 1 - 2	green	off	Signal voltage "0" (-3 V ... 5 V)
		on	Signal voltage "1" (15 V ... 30 V)

KL1012 - Connection

Terminal point		Description
Name	No.	
Input 1	1	Input 1
+24 V	2	Sensor supply for input 1 (internally connected to terminal point 6 and positive power contact)
0 V	3	Ground for input 1 (internally connected to terminal point 7 and negative power contact)
PE	4	PE (internally connected to terminal point 8)
Input 2	5	Input 2
+24 V	6	Sensor supply for input 2 (internally connected to terminal point 2 and positive power contact)
0 V	7	Ground for input 2 (internally connected to terminal point 3 and negative power contact)
PE	8	PE (internally connected to terminal point 4)

2.3 KL1104, KL1114 - Introduction

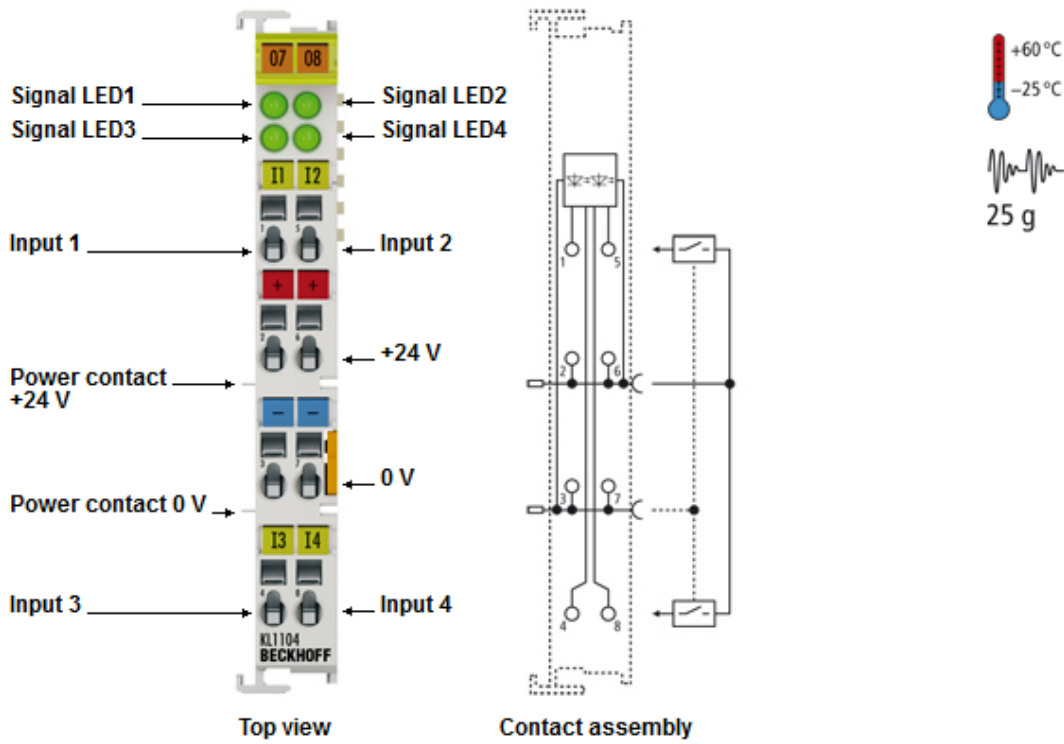

Fig. 5: KL1104

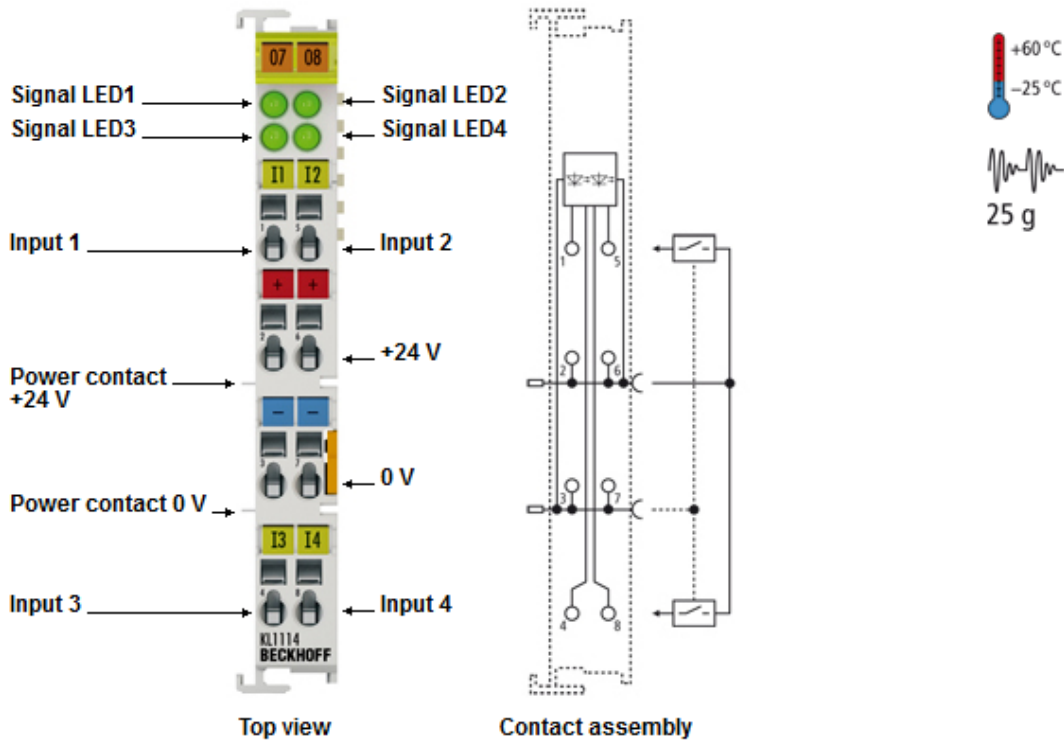

Fig. 6: KL1114

Four-channel, digital input terminals, 24 V_{DC}

The KL1104 and KL1114 digital input terminals acquire the binary control signals from the process level and transmit them, in an electrically isolated form, to the higher-level automation unit. The KL1104 and KL1114 versions have input filters of different speeds. The Bus Terminals contain four channels that indicate their signal state by means of light emitting diodes.

2.3.1 KL1104, KL1114 – Technical data

Technical data	KL1104, KS1104	KL1114, KS1114
Connection technology	2-wire / 3-wire	
Specification	EN 61131-2, type 1/3	
Number of inputs	4	
Nominal voltage	24 V _{DC} (-15 %/+20 %)	
Signal voltage '0'	-3 V to 5 V (EN 61131-2, type 1)	
Signal voltage '1'	15 V to 30 V (EN 61131-2, type 1)	
Input filter	3 ms	0.2 ms
Input current	typical 5 mA (EN 61131-2, type1)	
Current consumption from K-bus	typically 5 mA	
Electrical isolation	500 V (K-bus / field voltage)	
Bit width in process image	4 input bits	
Configuration	no address or configuration settings required	
Weight approx.	55 g	
Permissible ambient temperature during operation	-25°C ... +60°C (extended temperature range)	
Permissible ambient temperature during storage	-40°C ... +85°C	
Permissible relative humidity	95%, no condensation	
Vibration / shock resistance	according to EN 60068-2-6 / EN 60068-2-27, refer also to Installation instructions for enhanced mechanical load capacity [► 35]	
EMC immunity / emission	conforms to EN 61000-6-2 / EN 61000-6-4	
Installation position	variable	
Pluggable wiring	for all KSxxxx terminals	
Protection class	IP20	
Approvals	CE, cULus, ATEX [► 41], GL	

2.3.2 KL1104, KL1114 - LEDs and connection

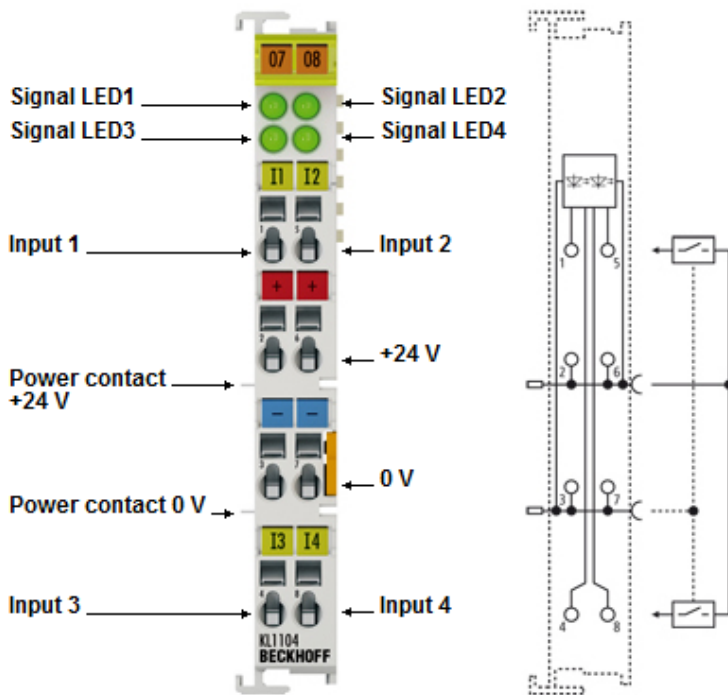

Fig. 7: KL1104

KL1104, KL1114 - LEDs

LED	Color	Meaning	
Signal LEDs 1 - 4	green	off	Signal voltage "0" (-3 V ... 5 V)
		on	Signal voltage "1" (15 V ... 30 V)

KL1104, KL1114 - Connection

Terminal point		Description
Name	No.	
Input 1	1	Input 1
+24 V	2	Sensor supply +24 V (internally connected to terminal point 6 and positive power contact)
0 V	3	Sensor supply 0 V (internally connected to terminal point 7 and negative power contact)
Input 3	4	Input 3
Input 2	5	Input 2
+24 V	6	Sensor supply +24 V (internally connected to terminal point 2 and positive power contact)
0 V	7	Sensor supply 0 V (internally connected to terminal point 3 and negative power contact)
Input 4	8	Input 4

2.4 KL1402, KL1412 - Introduction

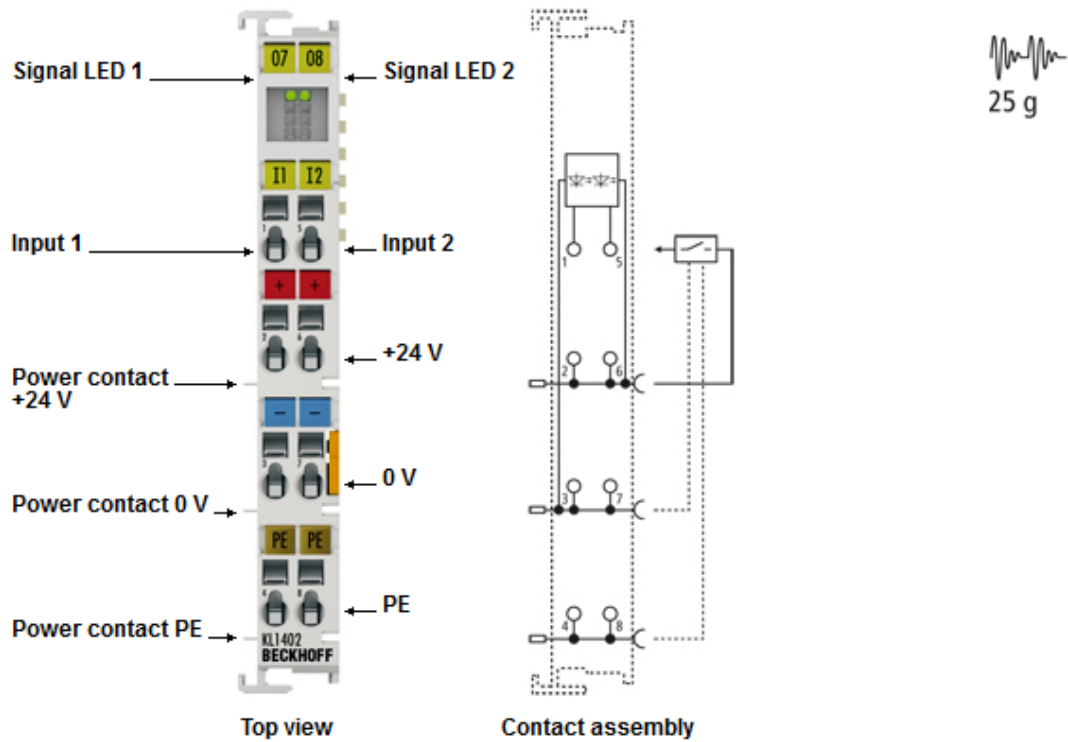

Fig. 8: KL1402

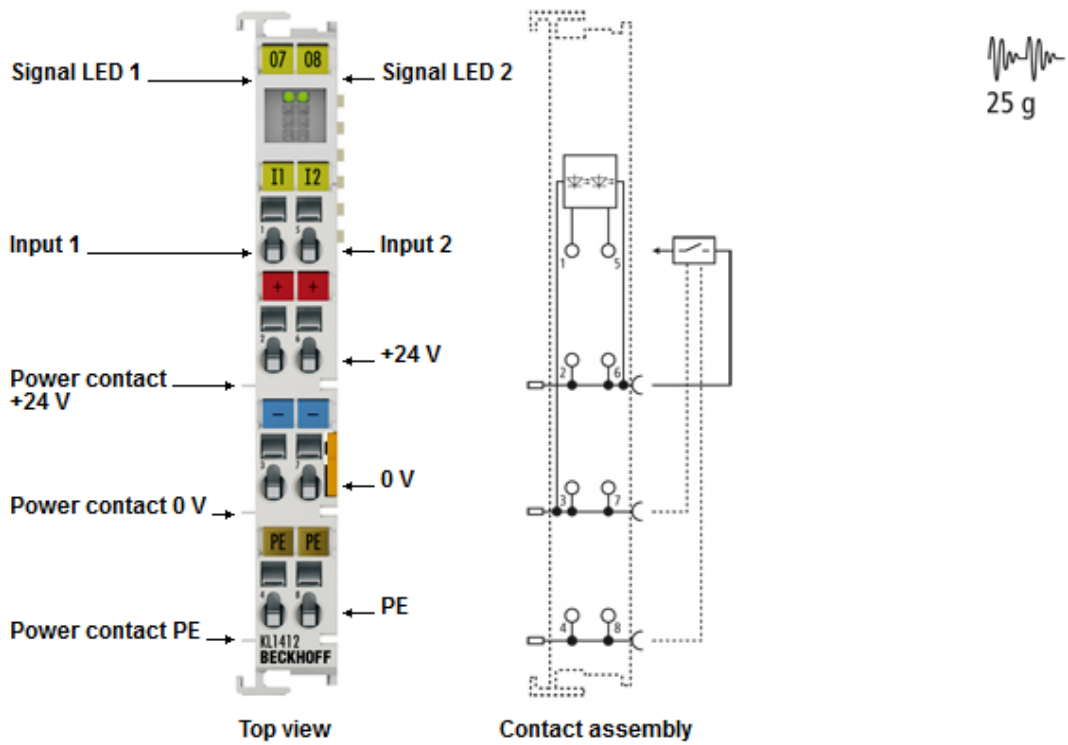

Fig. 9: KL1412

2-channel digital input terminal 24 V_{DC}, type 3

The KL1402 and KL1412 supplement the proven KL1404, KL1414, KL1408 und KL1418 digital input terminals with their type-3 specification. The current/voltage characteristics have been optimized for 2-wire sensors. The input current in low state is increased to a minimum value of 1.5 mA and therefore supports the majority of commercially available 2-wire sensors. A typical value for the energy-saving high current is 2.2 mA. The input complies with the EN 61131-2 type 3 standard and is compatible with type 1.

2.4.1 KL1402, KL1412 – Technical data

Technical data	KL1402, KS1402	KL1412, KS1412
Connection technology	4-wire	
Number of inputs	2	
Nominal voltage	24 V _{DC} (-15 %/+20 %)	
Signal voltage '0'	-3 V to +5 V (EN 61131-2, type 1/3)	
Signal voltage '1'	11 V to 30 V (EN 61131-2, type 3)	
Signal current "0"	0 to 1.5 mA	
Signal current "1"	2.0 to 2.5 mA	
Input filter	typically 3.0 ms	typically 0.2 ms
Current consumption from K-bus	typically 3 mA	
Current consumption power contacts	typ. 1 mA + load	
Electrical isolation	500 V (K-bus / field voltage)	
Bit width in process image	2 inputs	
Configuration	no address or configuration settings required	
Weight approx.	50 g	
Permissible ambient temperature during operation	0°C ... +55°C	
Permissible ambient temperature during storage	-25°C ... +85°C	
Permissible relative humidity	95%, no condensation	
Vibration / shock resistance	according to EN 60068-2-6 / EN 60068-2-27, refer also to Installation instructions for enhanced mechanical load capacity [► 35]	
EMC immunity / emission	conforms to EN 61000-6-2 / EN 61000-6-4	
Installation position	variable	
Protection class	IP20	
Pluggable wiring	for all KSxxxx terminals	
Approvals	CE, cULus, ATEX [► 40], GL	

2.4.2 KL1402, KL1412 - LEDs and connection

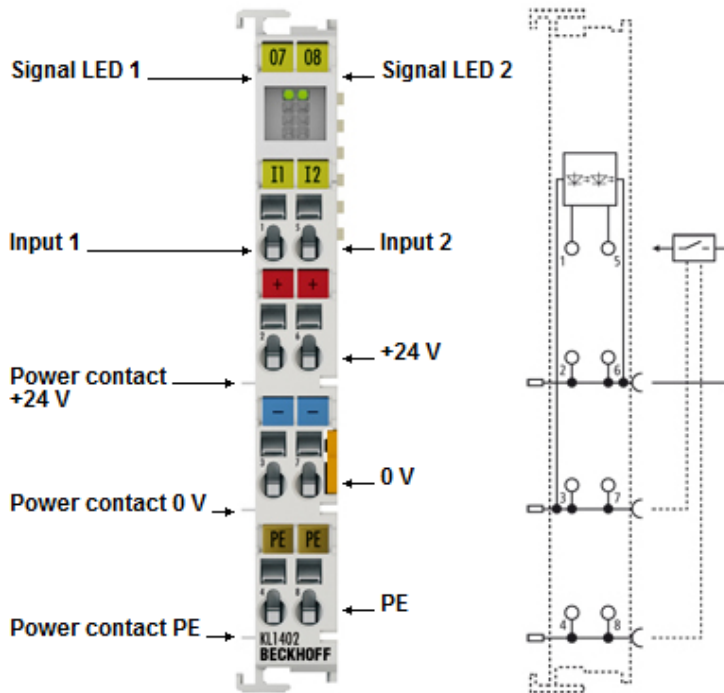

Fig. 10: KL1402

KL1402, KL1412 - LEDs

LED	Color	Meaning	
Signal LED 1 - 2	green	off	Signal voltage "0" (-3 V ... 5 V)
		on	Signal voltage "1" (15 V ... 30 V)

KL1402, KL1412 - Connection

Terminal point		Description
Name	No.	
Input 1	1	Input 1
+24 V	2	Sensor supply +24 V (internally connected to terminal point 6 and positive power contact)
+24 V	3	Sensor supply +24 V (internally connected to terminal point 7 and negative power contact)
Input 3	4	Input 3
Input 2	5	Input 2
+24 V	6	Sensor supply +24 V (internally connected to terminal point 2 and positive power contact)
+24 V	7	Sensor supply +24 V (internally connected to terminal point 3 and negative power contact)
Input 4	8	Input 4

2.5 KL1404, KL1414, KL1434 - Introduction

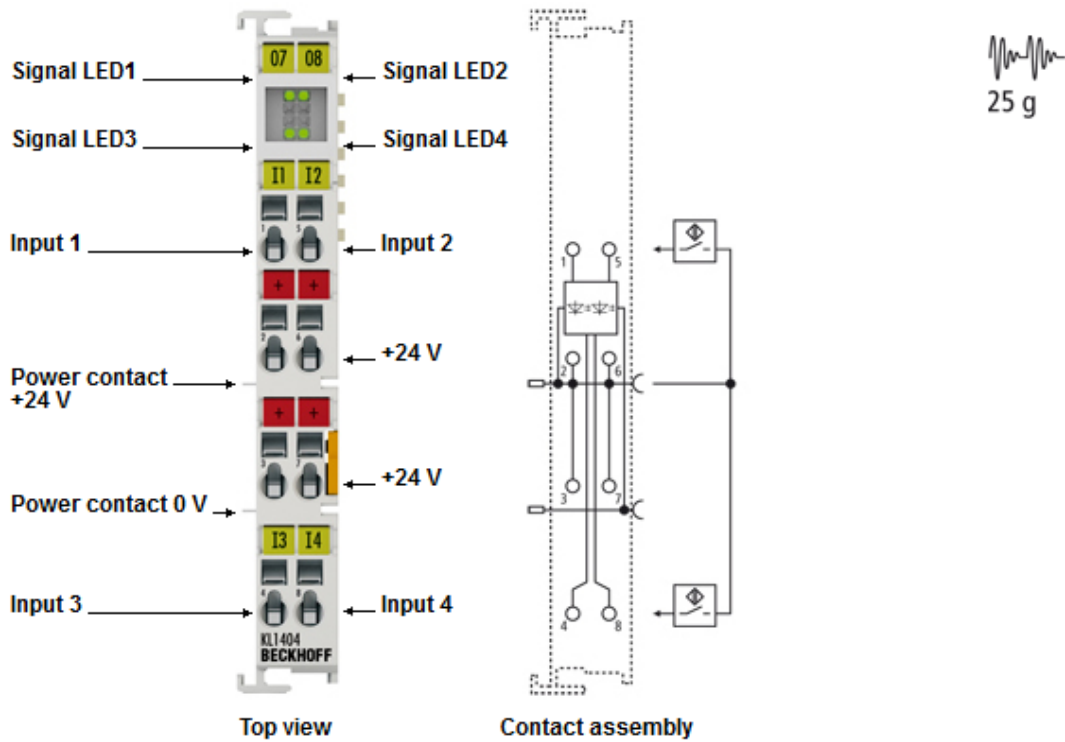

Fig. 11: KL1404

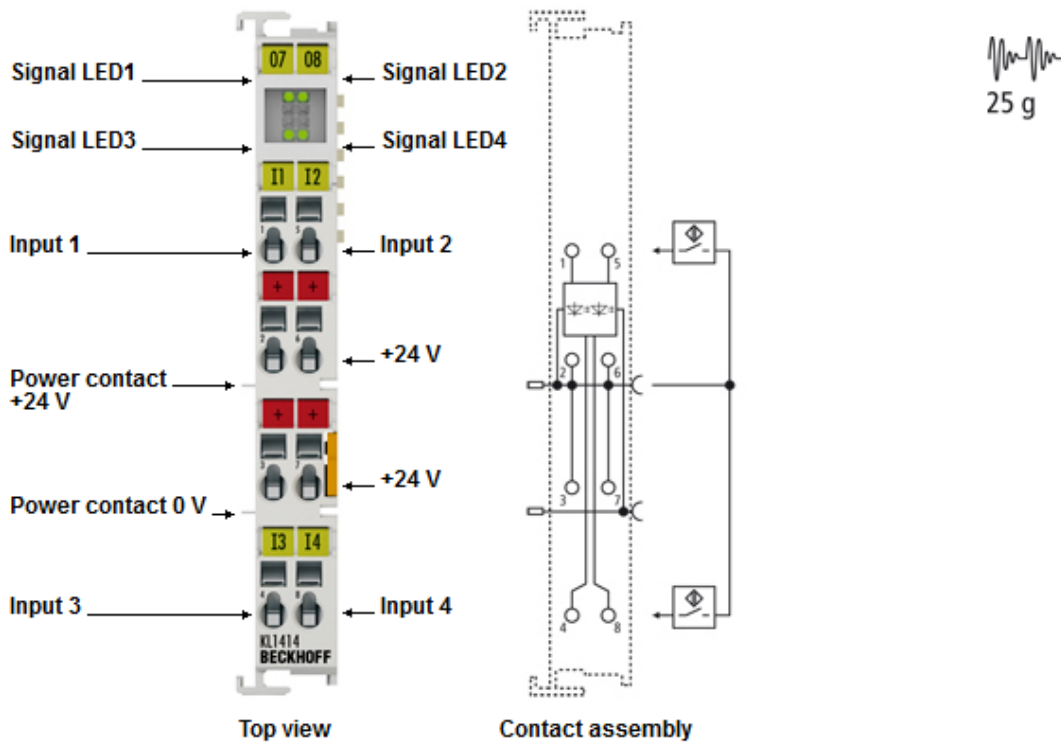

Fig. 12: KL1414

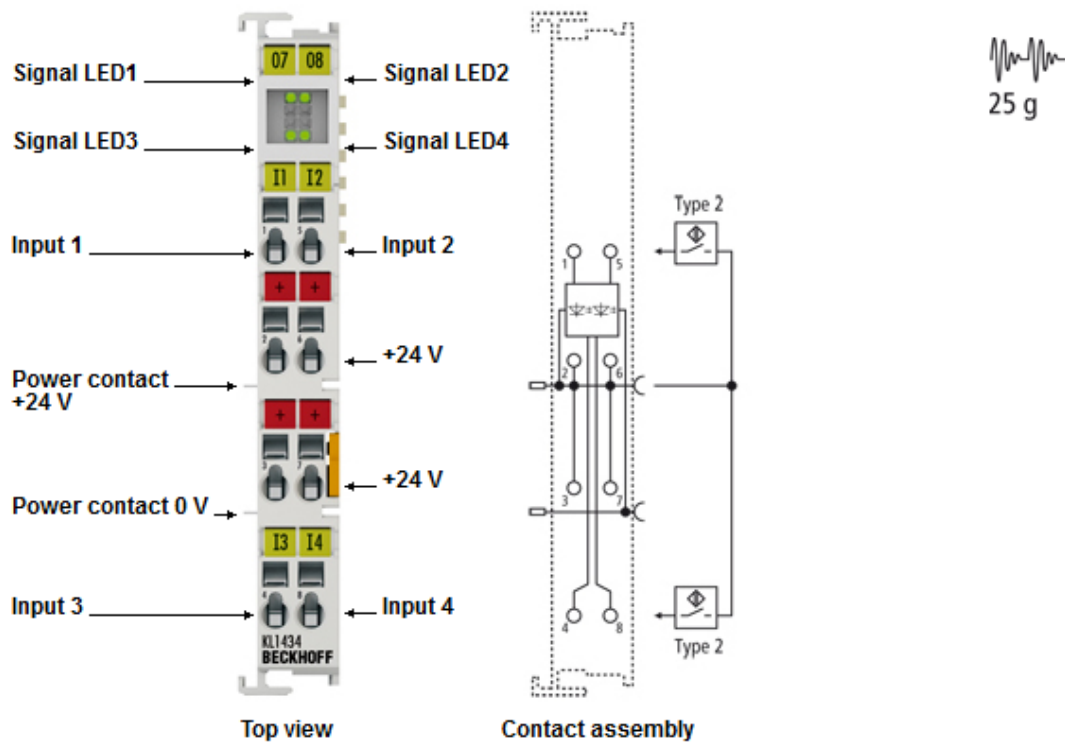

Fig. 13: KL1434

Four-channel, digital input terminals, 24 V_{DC}

The KL1404, KL1414 and KL1434 digital input terminals acquire the binary control signals (24 V) and transmit them, in an electrically isolated form, to the higher-level automation system. The Bus Terminals contain four channels that indicate their signal state by means of light emitting diodes. The KL1404, KL1414 and KL1434 versions have different input filters. The input signal of KL1404 and KL1414 corresponds to IEC 61131-2, type 1, that of KL1434 to type 2. In addition, these Bus Terminals enable direct connection of four 2-wire sensors. Four connection points for +24 V are provided.

2.5.1 KL1404, KL1414, KL1434 - Technical data

Technical data	KL1404, KS1404	KL1414, KS1414	KL1434, KS1434
Connection technology	2-wire		
Number of inputs	4		
Nominal voltage	24 V _{DC} (-15 %/+20 %)		
Signal voltage '0'	-3 V to 5 V (EN 61131-2, type 1)	-3 V to 5 V (EN 61131-2, type 2)	
Signal voltage '1'	15 V to 30 V (EN 61131-2, type 1)	11 V to 30 V (EN 61131-2, type 2)	
Input filter	3 ms	0.2 ms	
Input current	typically 3 mA (EN 61131-2, type 1)	typically 6 mA (EN 61131-2, type 2)	
Current consumption from K-bus	typically 3 mA		
Electrical isolation	500 V (K-bus / field voltage)		
Bit width in process image	4 input bits		
Configuration	no address or configuration settings required		
Dimensions (W x H x D)	15 mm x 100 mm x 70 mm (connected width 12 mm)		
Weight approx.	50 g		
Permissible ambient temperature during operation	0°C ... +55°C		
Permissible ambient temperature during storage	-25°C ... +85°C		
Permissible relative humidity	95%, no condensation		
Vibration / shock resistance	according to EN 60068-2-6 / EN 60068-2-27, refer also to Installation instructions for enhanced mechanical load capacity [► 35]		
EMC immunity / emission	conforms to EN 61000-6-2 / EN 61000-6-4		
Installation position	variable		
Protection class	IP20		
Pluggable wiring	for all KSxxxx terminals		
Approvals	CE, cULus, ATEX [► 40], GL		CE, cULus, ATEX [► 40]

2.5.2 KL1404, KL1414 - LEDs and connection

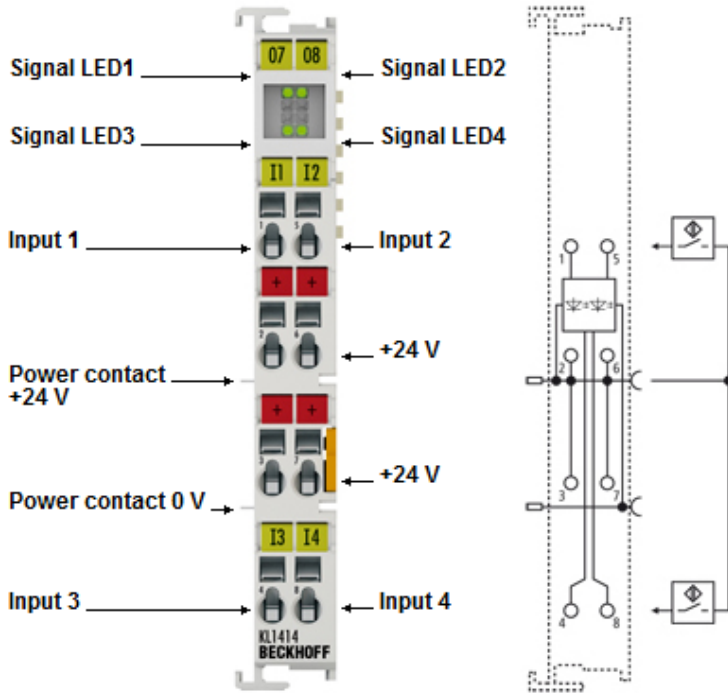

Fig. 14: KL1414

KL1404, KL1414 - LEDs

LED	Color	Meaning	
Signal LED 1 - 4	green	off	Signal voltage "0" (-3 V ... 5 V)
		on	Signal voltage "1" (15 V ... 30 V)

KL1404, KL1414 - Connection

Terminal point		Description
Name	No.	
Input 1	1	Input 1
+24 V	2	Sensor supply +24 V (internally connected to terminal point 6 and positive power contact)
+24 V	3	Sensor supply +24 V (internally connected to terminal point 7 and negative power contact)
Input 3	4	Input 3
Input 2	5	Input 2
+24 V	6	Sensor supply +24 V (internally connected to terminal point 2 and positive power contact)
+24 V	7	Sensor supply +24 V (internally connected to terminal point 3 and negative power contact)
Input 4	8	Input 4

2.5.3 KL1434 - LEDs and connection

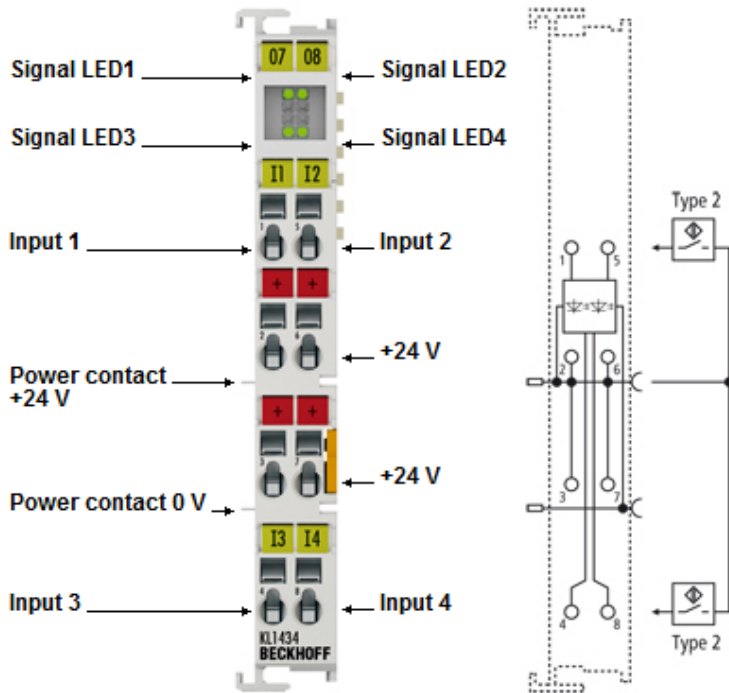

Fig. 15: KL1434

KL1434 - LEDs

LED	Color	Meaning	
Signal LED 1 - 4	green	off	Signal voltage "0" (-3 V ... 5 V)
		on	Signal voltage "1" (11 V ... 30 V)

KL1434 - Connection

Terminal point		Description
Name	No.	
Input 1	1	Input 1
+24 V	2	Sensor supply +24 V (internally connected to terminal point 6 and positive power contact)
+24 V	3	Sensor supply +24 V (internally connected to terminal point 7 and negative power contact)
Input 3	4	Input 3
Input 2	5	Input 2
+24 V	6	Sensor supply +24 V (internally connected to terminal point 2 and positive power contact)
+24 V	7	Sensor supply +24 V (internally connected to terminal point 3 and negative power contact)
Input 4	8	Input 4

2.6 KL1408, KL1418, KL1488, KL1498 - Introduction

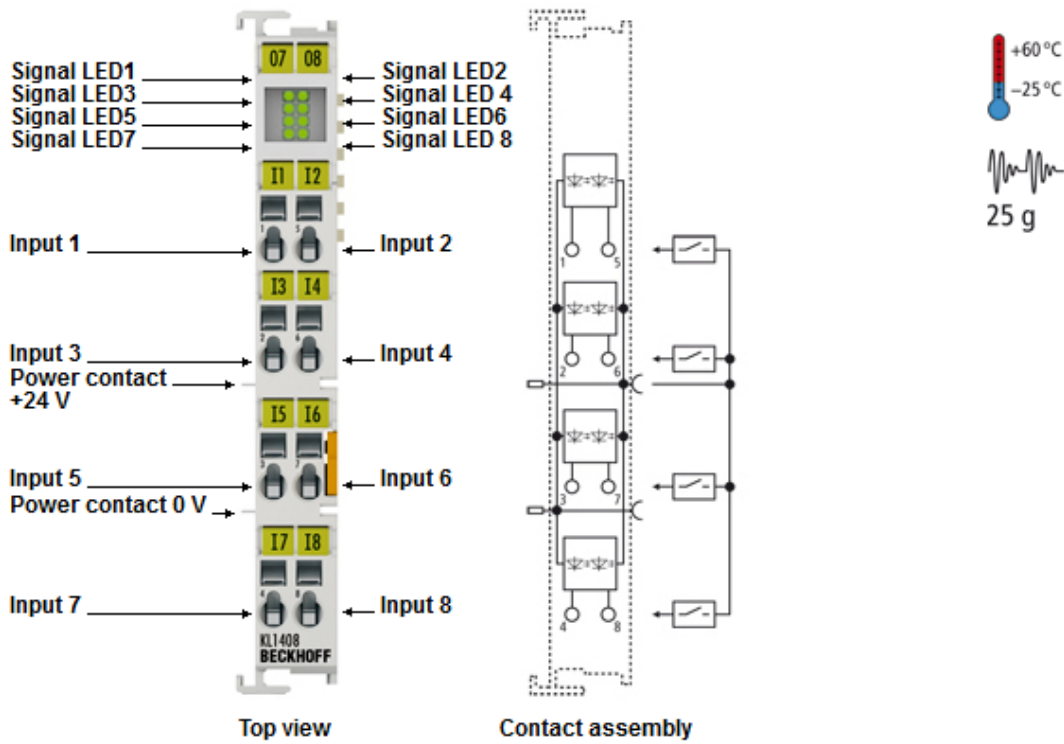

Fig. 16: KL1408

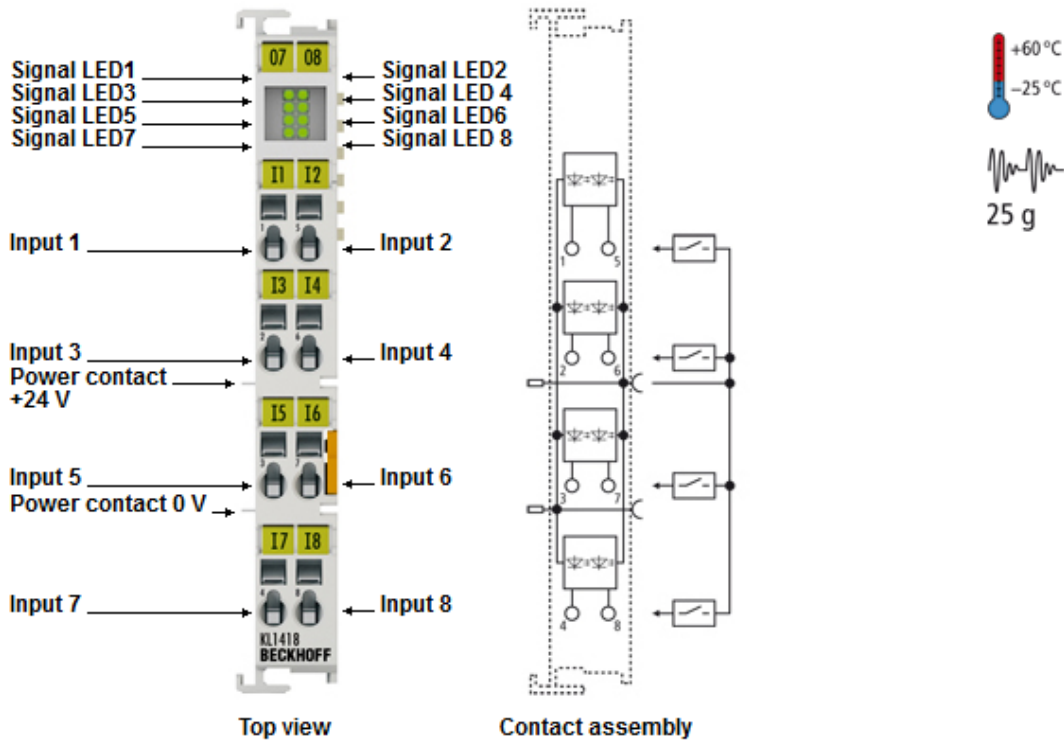

Fig. 17: KL1418

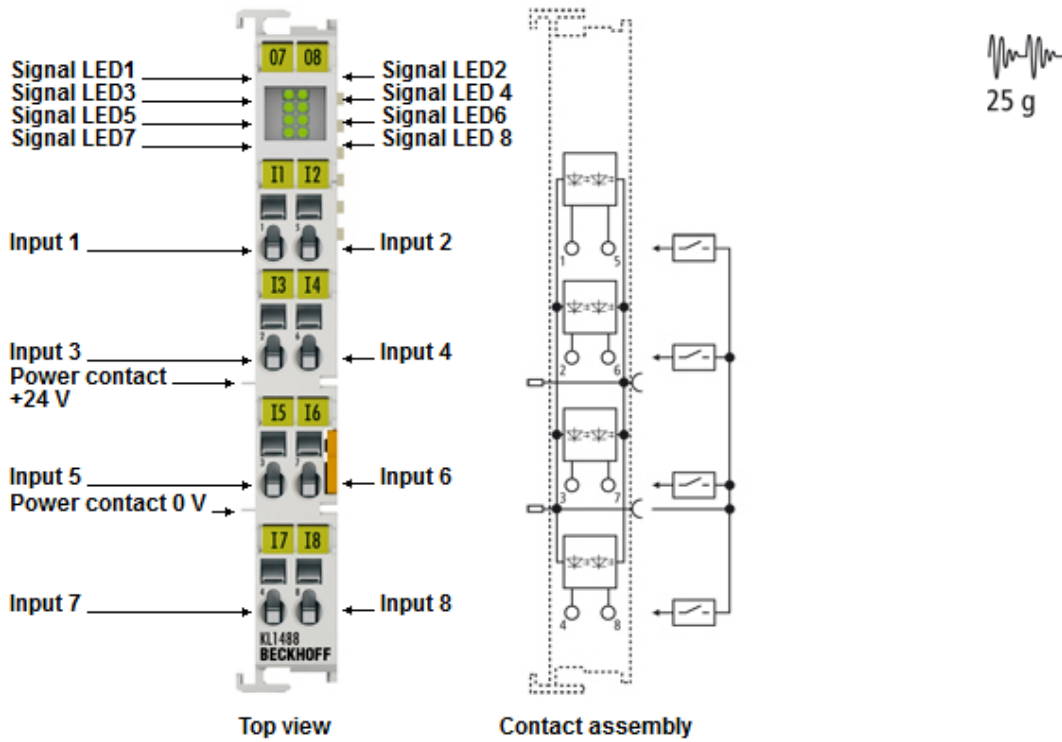

Fig. 18: KL1488

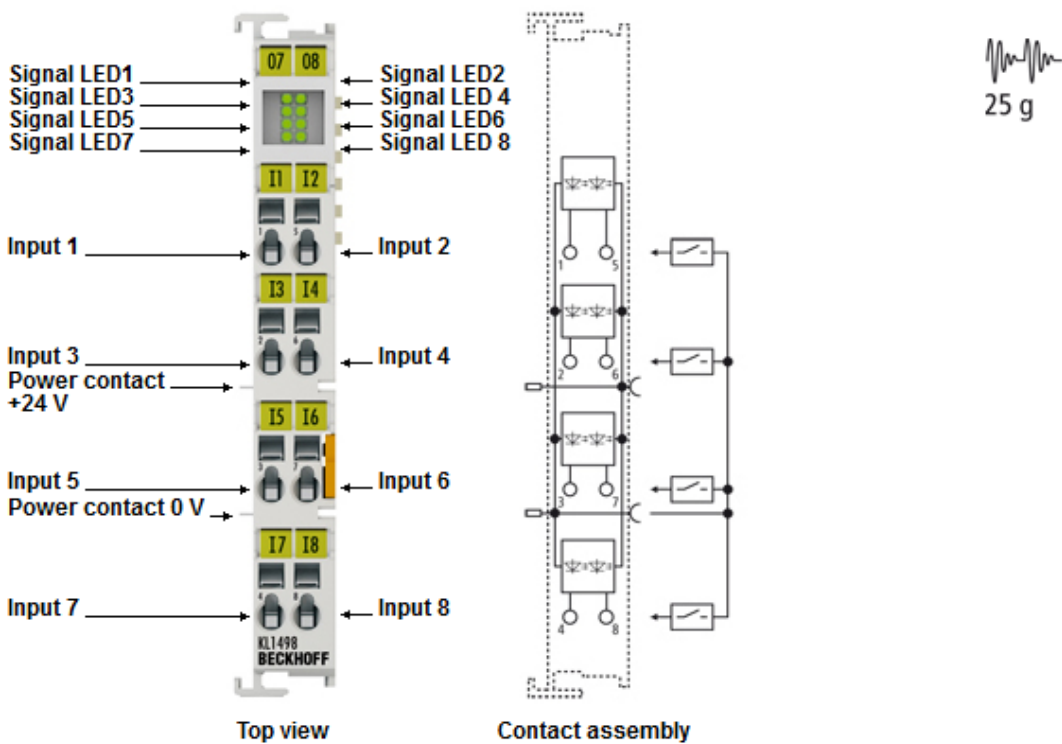

Fig. 19: KL1498

Eight-channel, digital input terminals, 24 V_{DC}

The digital input terminals KL1408 and KL1418 (positive switching) and KL1488 and KL1498 (negative switching) acquire the binary control signals from the process level and transmit them, in an electrically isolated form, to the higher-level automation unit. The Bus Terminals each contain eight channels, whose signal states are displayed by LEDs. They are particularly suitable for space-saving use in control cabinets. By using the single-conductor connection technique a multi-channel sensor can be connected in the smallest space with a minimum amount of wiring. The power contacts are looped through. For the KL1408 and KL1418 Bus Terminals, the reference ground for all inputs is the 0 V power contact. For the KL1488 and KL1498 Bus Terminals, the reference point for all inputs is the 24 V power contact. These versions have input filters with different speeds.

2.6.1 KL1408, KL1418, KL1488, KL1498 – Technical data

Technical data	KL1408, KS1408	KL1418, KS1418	KL1488, KS1488	KL1498, KS1498
Connection technology	1-wire			
Number of inputs	8			
Nominal voltage	24 V _{DC} (-15 %/+20 %)			
Signal voltage '0'	-3 V to 5 V (EN 61131-2, type 1)		18 V ... 30 V	
Signal voltage '1'	15 V to 30 V (EN 61131-2, type 1)		0 V ... 7 V	
Signal current '0'	0 to 1.5 mA	0 to 1.5 mA	-	-
Signal current '1'	2.0 to 2.5 mA	2.0 to 2.5 mA	typ. 3 mA	typ. 3 mA
Input filter	3 ms	0.2 ms	3 ms	0.2 ms
Current consumption from K-bus	typically 5 mA			
Electrical isolation	500 V (K-bus / field voltage)			
Bit width in process image	8 input bits			
Configuration	no address or configuration settings required			
Dimensions (W x H x D)	15 mm x 100 mm x 70 mm (connected width 12 mm)			
Weight approx.	55 g			
Permissible ambient temperature during operation	-25°C ... +60°C (extended temperature range)		0°C ... +55°C	
Permissible ambient temperature during storage	-40°C ... +85°C		-25°C ... +85°C	
Permissible relative humidity	95%, no condensation			
Vibration / shock resistance	according to EN 60068-2-6 / EN 60068-2-27, refer also to Installation instructions for enhanced mechanical load capacity [▶ 35]			
EMC immunity / emission	conforms to EN 61000-6-2 / EN 61000-6-4			
Installation position	variable			
Protection class	IP20			
Pluggable wiring	for all KSxxxx terminals			
Approvals	CE, cULus, ATEX [▶ 41], GL		CE, cULus, ATEX [▶ 41]	

2.6.2 KL1408, KL1418 - LEDs and connection

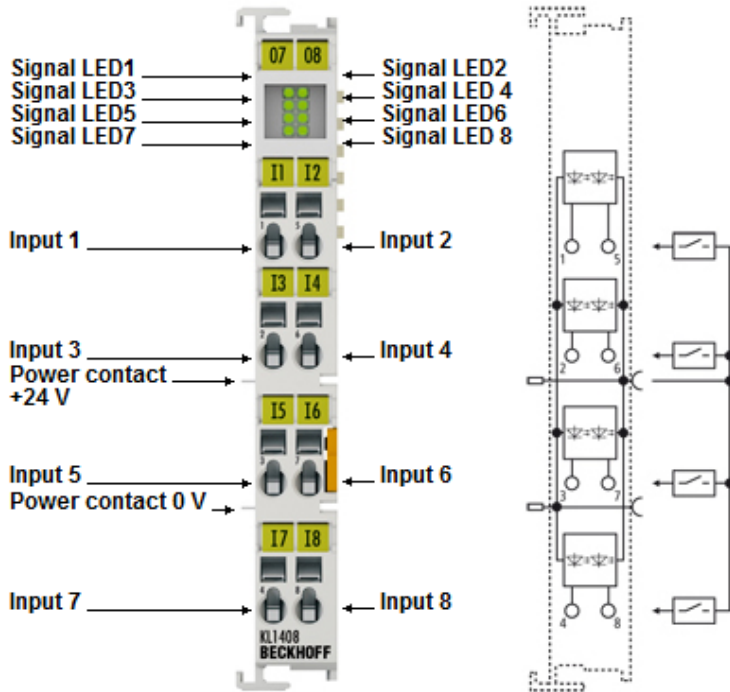

Fig. 20: KL1408

KL1408, KL1418 - LEDs

LED	Color	Meaning	
Signal LED 1 - 8	green	off	Signal voltage "0" (-3 V ... 5 V)
		on	Signal voltage "1" (15 V ... 30 V)

KL1408, KL1418 - Connection

Terminal point		Description
Name	No.	
Input 1	1	Input 1
Input 3	2	Input 3
Input 5	3	Input 5
Input 7	4	Input 7
Input 2	5	Input 2
Input 4	6	Input 4
Input 6	7	Input 6
Input 8	8	Input 8

2.6.3 KL1488, KL1498 - LEDs and connection

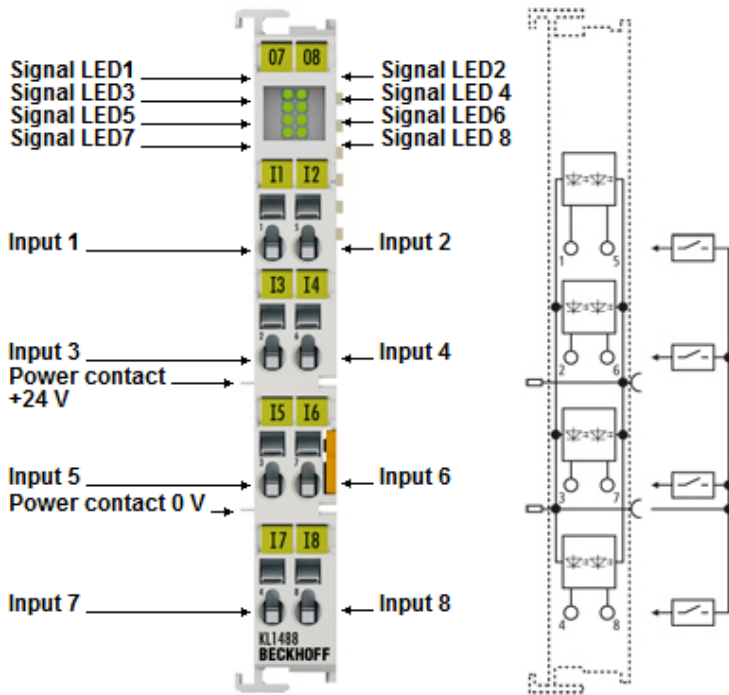

Fig. 21: KL1488

KL1488, KL1498 - LEDs

LED	Color	Meaning	
Signal LED 1 - 8	green	off	Signal voltage "0" (18 V ... 30 V)
		on	Signal voltage "1" (0 V ... 7 V)

KL1488, KL1498 - Connection

Terminal point		Description
Name	No.	
Input 1	1	Input 1
Input 3	2	Input 3
Input 5	3	Input 5
Input 7	4	Input 7
Input 2	5	Input 2
Input 4	6	Input 4
Input 6	7	Input 6
Input 8	8	Input 8

2.7 KL1862, KL1862-0010, KL1872 - Introduction

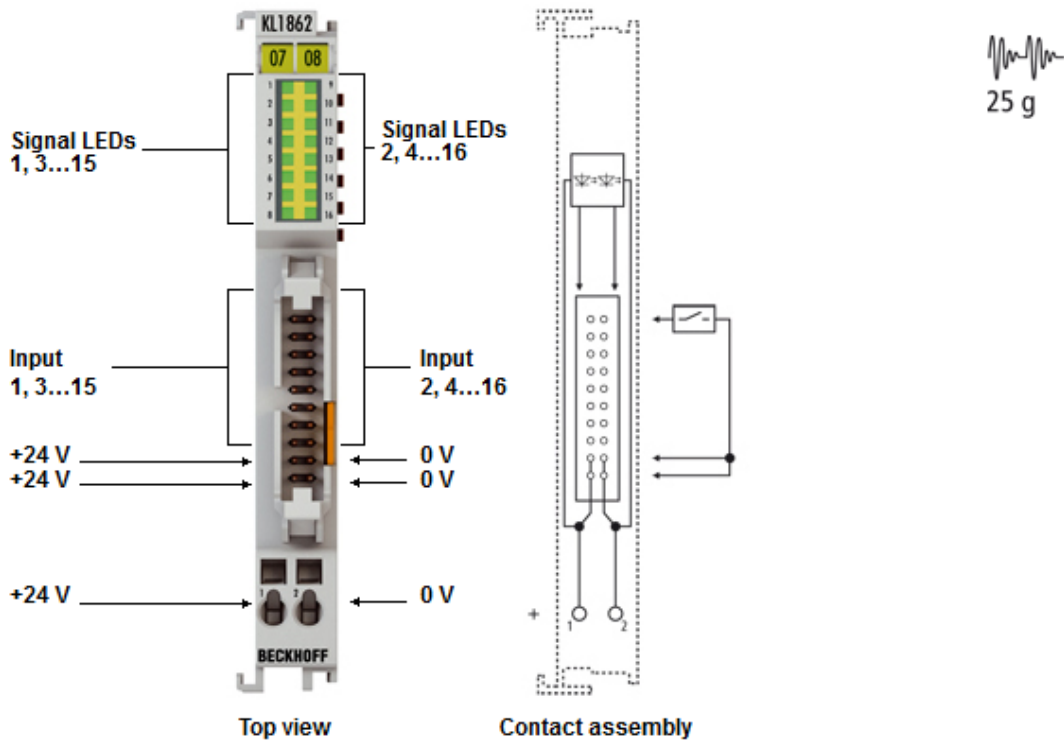

Fig. 22: KL1862

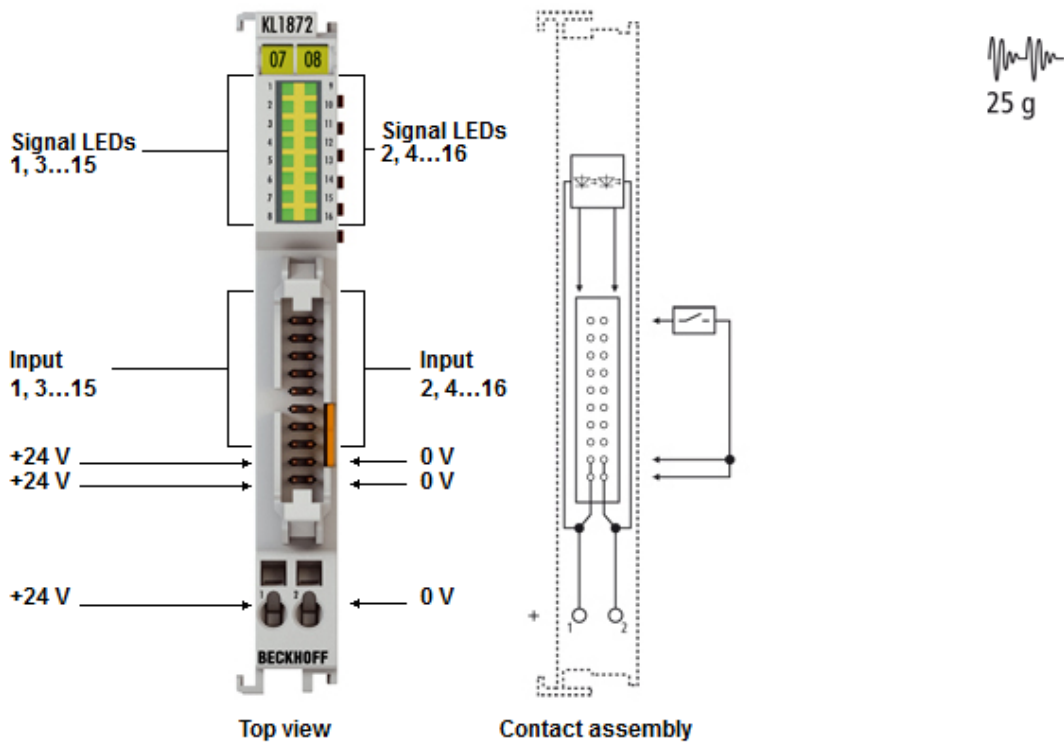

Fig. 23: KL1872

16-channel digital input terminal with ribbon cable connection, 24 V_{DC}

The KL1862 and KL1872 digital input terminals offer a very compact design with their 16 channels. A 20-pin connector enables the secure connection of plug connectors using insulation displacement contact, as is usual for ribbon cables and special round cables. This significantly simplifies the wiring of many channels. The input characteristic conforms to the type-3 specification and guarantees minimum power dissipation. 16 LEDs display the logical signal states of the inputs.

2.7.1 KL1862, KL1862-0010, KL1872 – Technical data

Technical data	KL1862	KL1862-0010	KL1872
Connection technology	Ribbon cable		
Specification	EN 61131-2, type 1/3	negative switching	EN 61131-2, type 1/3
Number of inputs	16		
Nominal voltage	24 V _{DC} (-15 %/+20 %)		
Signal voltage '0'	-3 V to 5 V (EN 61131-2, type 1/3)		
Signal voltage '1'	11 V to 30 V (EN 61131-2, type 3)		
Signal current '0'	0 mA to 1.5 mA		
Signal current '1'	2.0 mA to 2.5 mA		
Input filter	3 ms		0.2 ms
Current consumption from K-bus	typically 3 mA		
Electrical isolation	500 V (K-bus / field voltage)		
Bit width in process image	16 input bits		
Configuration	no address or configuration settings required		
Weight approx.	50 g		
Permissible ambient temperature during operation	0°C ... +55°C (extended temperature range)		
Permissible ambient temperature during storage	-25°C ... +85°C		
Permissible relative humidity	95%, no condensation		
Vibration / shock resistance	according to EN 60068-2-6 / EN 60068-2-27, refer also to Installation instructions for enhanced mechanical load capacity [▶ 35]		
EMC immunity / emission	conforms to EN 61000-6-2 / EN 61000-6-4		
Installation position	variable		
Protection class	IP20		
Approvals	CE, cULus, ATEX [▶ 41]		

2.7.2 KL1862, KL1872 - LEDs and connection

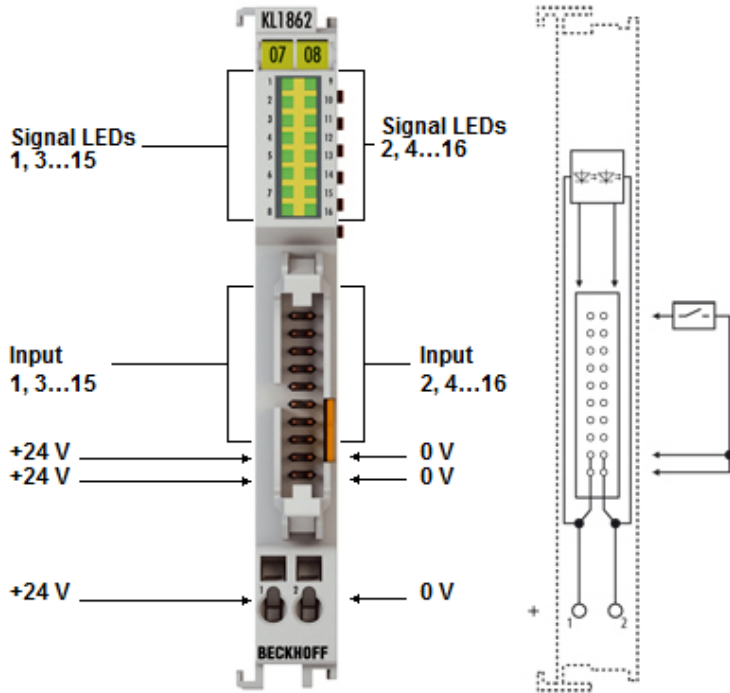

Fig. 24: KL1862

KL1862, KL1872 - LEDs

LED	Color	Meaning	
Signal LED 1 - 16	green	off	Signal voltage "0" (-3 V ... 5 V)
		on	Signal voltage "1" (11 V ... 30 V)

KL1862, KL1872 – Connection

2 x 10 pin connector RM 2.54 mm with locking mechanism for connecting a 2 x 10 pin plug connector (post socket with insulation displacement contact for ribbon cable); standard ribbon cable connector (standardized according to IEC 60603-13).

3 Mounting and wiring

3.1 Installation on mounting rails

⚠ WARNING

Risk of electric shock and damage of device!

Bring the bus terminal system into a safe, powered down state before starting installation, disassembly or wiring of the bus terminals!

Assembly

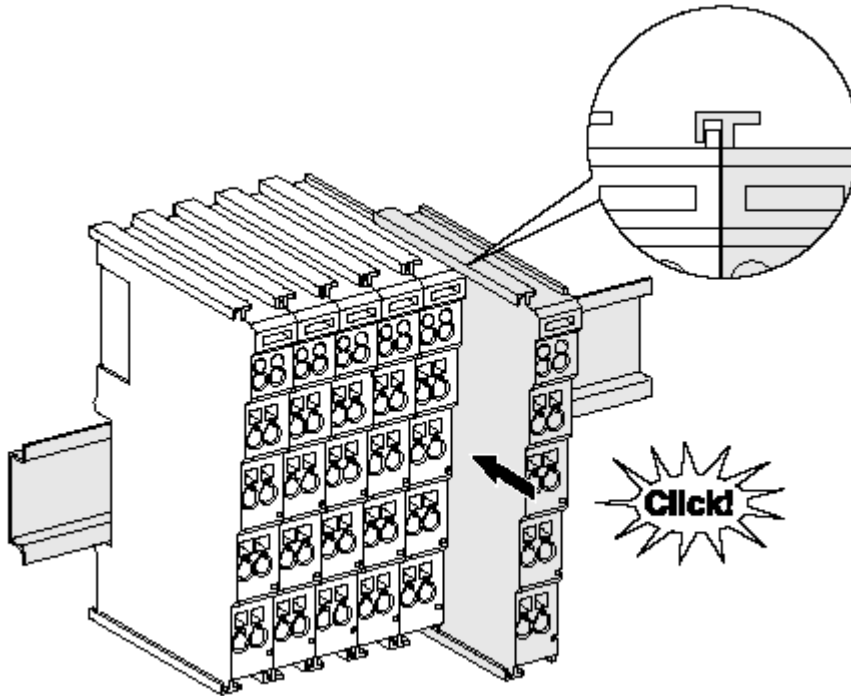

Fig. 25: Attaching on mounting rail

The bus coupler and bus terminals are attached to commercially available 35 mm mounting rails (DIN rails according to EN 60715) by applying slight pressure:

1. First attach the fieldbus coupler to the mounting rail.
2. The bus terminals are now attached on the right-hand side of the fieldbus coupler. Join the components with tongue and groove and push the terminals against the mounting rail, until the lock clicks onto the mounting rail.

If the terminals are clipped onto the mounting rail first and then pushed together without tongue and groove, the connection will not be operational! When correctly assembled, no significant gap should be visible between the housings.

i Fixing of mounting rails

The locking mechanism of the terminals and couplers extends to the profile of the mounting rail. At the installation, the locking mechanism of the components must not come into conflict with the fixing bolts of the mounting rail. To mount the mounting rails with a height of 7.5 mm under the terminals and couplers, you should use flat mounting connections (e.g. countersunk screws or blind rivets).

Disassembly

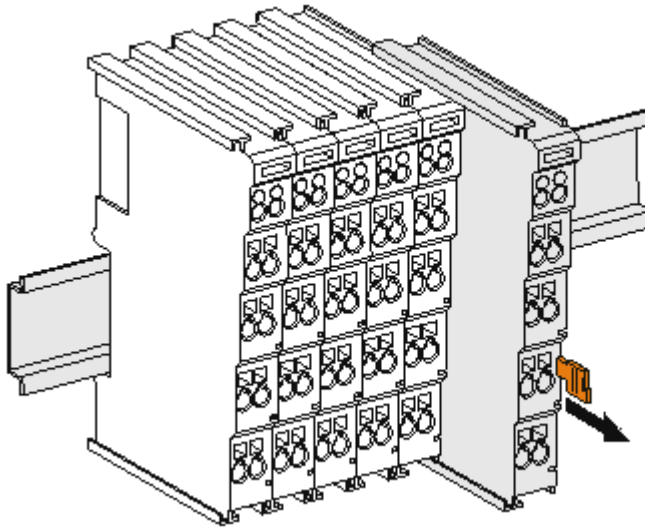

Fig. 26: Disassembling of terminal

Each terminal is secured by a lock on the mounting rail, which must be released for disassembly:

1. Pull the terminal by its orange-colored lugs approximately 1 cm away from the mounting rail. In doing so for this terminal the mounting rail lock is released automatically and you can pull the terminal out of the bus terminal block easily without excessive force.
2. Grasp the released terminal with thumb and index finger simultaneous at the upper and lower grooved housing surfaces and pull the terminal out of the bus terminal block.

Connections within a bus terminal block

The electric connections between the Bus Coupler and the Bus Terminals are automatically realized by joining the components:

- The six spring contacts of the K-Bus/E-Bus deal with the transfer of the data and the supply of the Bus Terminal electronics.
- The power contacts deal with the supply for the field electronics and thus represent a supply rail within the bus terminal block. The power contacts are supplied via terminals on the Bus Coupler (up to 24 V) or for higher voltages via power feed terminals.

● Power Contacts
i

During the design of a bus terminal block, the pin assignment of the individual Bus Terminals must be taken account of, since some types (e.g. analog Bus Terminals or digital 4-channel Bus Terminals) do not or not fully loop through the power contacts. Power Feed Terminals (KL91xx, KL92xx or EL91xx, EL92xx) interrupt the power contacts and thus represent the start of a new supply rail.

PE power contact

The power contact labeled PE can be used as a protective earth. For safety reasons this contact mates first when plugging together, and can ground short-circuit currents of up to 125 A.

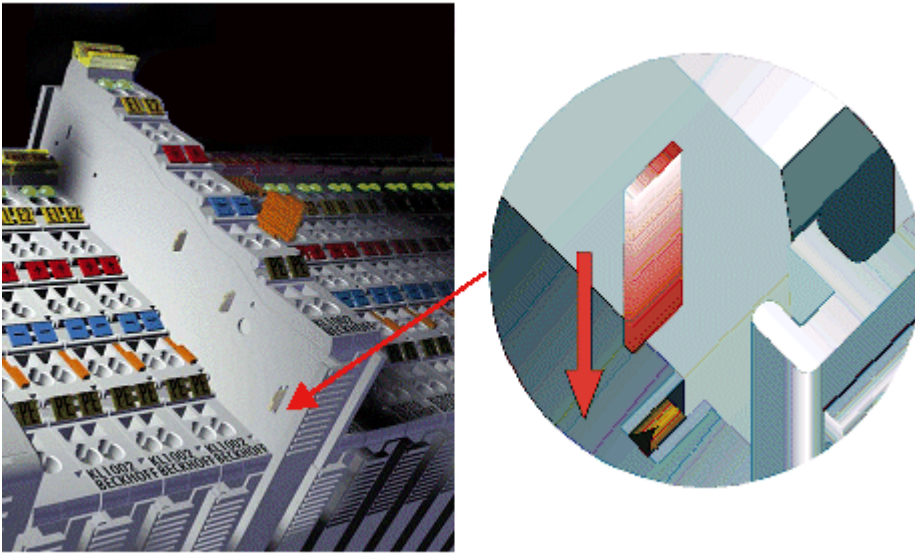

Fig. 27: Power contact on left side

NOTE**Possible damage of the device**

Note that, for reasons of electromagnetic compatibility, the PE contacts are capacitatively coupled to the mounting rail. This may lead to incorrect results during insulation testing or to damage on the terminal (e.g. disruptive discharge to the PE line during insulation testing of a consumer with a nominal voltage of 230 V). For insulation testing, disconnect the PE supply line at the Bus Coupler or the Power Feed Terminal! In order to decouple further feed points for testing, these Power Feed Terminals can be released and pulled at least 10 mm from the group of terminals.

⚠ WARNING**Risk of electric shock!**

The PE power contact must not be used for other potentials!

3.2 Installation instructions for enhanced mechanical load capacity

⚠ WARNING

Risk of injury through electric shock and damage to the device!

Bring the Bus Terminal system into a safe, de-energized state before starting mounting, disassembly or wiring of the Bus Terminals!

Additional checks

The terminals have undergone the following additional tests:

Verification	Explanation
Vibration	10 frequency runs in 3 axes
	6 Hz < f < 60 Hz displacement 0.35 mm, constant amplitude
	60.1 Hz < f < 500 Hz acceleration 5 g, constant amplitude
Shocks	1000 shocks in each direction, in 3 axes
	25 g, 6 ms

Additional installation instructions

For terminals with enhanced mechanical load capacity, the following additional installation instructions apply:

- The enhanced mechanical load capacity is valid for all permissible installation positions
- Use a mounting rail according to EN 60715 TH35-15
- Fix the terminal segment on both sides of the mounting rail with a mechanical fixture, e.g. an earth terminal or reinforced end clamp
- The maximum total extension of the terminal segment (without coupler) is: 64 terminals (12 mm mounting with) or 32 terminals (24 mm mounting with)
- Avoid deformation, twisting, crushing and bending of the mounting rail during edging and installation of the rail
- The mounting points of the mounting rail must be set at 5 cm intervals
- Use countersunk head screws to fasten the mounting rail
- The free length between the strain relief and the wire connection should be kept as short as possible. A distance of approx. 10 cm should be maintained to the cable duct.

3.3 Connection

3.3.1 Connection system

⚠ WARNING

Risk of electric shock and damage of device!

Bring the bus terminal system into a safe, powered down state before starting installation, disassembly or wiring of the bus terminals!

Overview

The Bus Terminal system offers different connection options for optimum adaptation to the respective application:

- The terminals of ELxxxx and KLxxxx series with standard wiring include electronics and connection level in a single enclosure.

- The terminals of ESxxxx and KSxxxx series feature a pluggable connection level and enable steady wiring while replacing.
- The High Density Terminals (HD Terminals) include electronics and connection level in a single enclosure and have advanced packaging density.

Standard wiring (ELxxxx / KLxxxx)

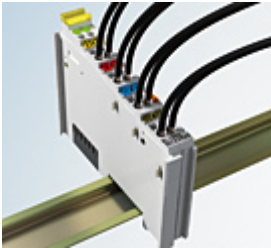

Fig. 28: Standard wiring

The terminals of ELxxxx and KLxxxx series have been tried and tested for years. They feature integrated screwless spring force technology for fast and simple assembly.

Pluggable wiring (ESxxxx / KSxxxx)



Fig. 29: Pluggable wiring

The terminals of ESxxxx and KSxxxx series feature a pluggable connection level. The assembly and wiring procedure is the same as for the ELxxxx and KLxxxx series. The pluggable connection level enables the complete wiring to be removed as a plug connector from the top of the housing for servicing. The lower section can be removed from the terminal block by pulling the unlocking tab. Insert the new component and plug in the connector with the wiring. This reduces the installation time and eliminates the risk of wires being mixed up.

The familiar dimensions of the terminal only had to be changed slightly. The new connector adds about 3 mm. The maximum height of the terminal remains unchanged.

A tab for strain relief of the cable simplifies assembly in many applications and prevents tangling of individual connection wires when the connector is removed.

Conductor cross sections between 0.08 mm² and 2.5 mm² can continue to be used with the proven spring force technology.

The overview and nomenclature of the product names for ESxxxx and KSxxxx series has been retained as known from ELxxxx and KLxxxx series.

High Density Terminals (HD Terminals)



Fig. 30: High Density Terminals

The Bus Terminals from these series with 16 terminal points are distinguished by a particularly compact design, as the packaging density is twice as large as that of the standard 12 mm Bus Terminals. Massive conductors and conductors with a wire end sleeve can be inserted directly into the spring loaded terminal point without tools.

● **Wiring HD Terminals**

i The High Density Terminals of the ELx8xx and KLx8xx series doesn't support pluggable wiring.

Ultrasonically "bonded" (ultrasonically welded) conductors

● **Ultrasonically "bonded" conductors**

i It is also possible to connect the Standard and High Density Terminals with ultrasonically "bonded" (ultrasonically welded) conductors. In this case, please note the tables concerning the wire-size width below!

3.3.2 Wiring

⚠ WARNING

Risk of electric shock and damage of device!

Bring the bus terminal system into a safe, powered down state before starting installation, disassembly or wiring of the Bus Terminals!

Terminals for standard wiring ELxxxx/KLxxxx and for pluggable wiring ESxxxx/KSxxxx

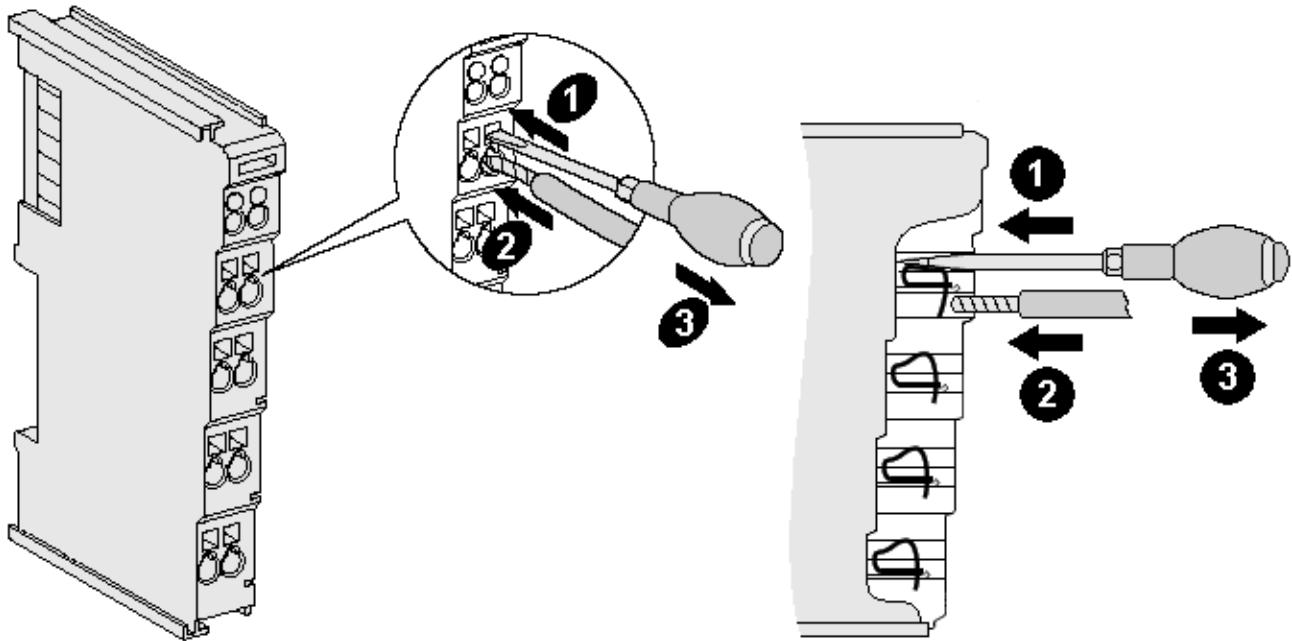

Fig. 31: Connecting a cable on a terminal point

Up to eight terminal points enable the connection of solid or finely stranded cables to the Bus Terminal. The terminal points are implemented in spring force technology. Connect the cables as follows:

1. Open a terminal point by pushing a screwdriver straight against the stop into the square opening above the terminal point. Do not turn the screwdriver or move it alternately (don't toggle).
2. The wire can now be inserted into the round terminal opening without any force.
3. The terminal point closes automatically when the pressure is released, holding the wire securely and permanently.

See the following table for the suitable wire size width.

Terminal housing	ELxxxx, KLxxxx	ESxxxx, KSxxxx
Wire size width (single core wires)	0.08 ... 2.5 mm ²	0.08 ... 2.5 mm ²
Wire size width (fine-wire conductors)	0.08 ... 2.5 mm ²	0,08 ... 2.5 mm ²
Wire size width (conductors with a wire end sleeve)	0.14 ... 1.5 mm ²	0.14 ... 1.5 mm ²
Wire stripping length	8 ... 9 mm	9 ... 10 mm

High Density Terminals (HD Terminals [[▶ 37](#)]) with 16 terminal points

The conductors of the HD Terminals are connected without tools for single-wire conductors using the direct plug-in technique, i.e. after stripping the wire is simply plugged into the terminal point. The cables are released, as usual, using the contact release with the aid of a screwdriver. See the following table for the suitable wire size width.

Terminal housing	High Density Housing
Wire size width (single core wires)	0.08 ... 1.5 mm ²
Wire size width (fine-wire conductors)	0.25 ... 1.5 mm ²
Wire size width (conductors with a wire end sleeve)	0.14 ... 0.75 mm ²
Wire size width (ultrasonically "bonded" conductors)	only 1.5 mm ²
Wire stripping length	8 ... 9 mm

3.3.3 Shielding



Shielding

Encoder, analog sensors and actors should always be connected with shielded, twisted paired wires.

3.4 ATEX - Special conditions (standard temperature range)

⚠ WARNING

Observe the special conditions for the intended use of Beckhoff fieldbus components with standard temperature range in potentially explosive areas (directive 2014/34/EU)!

- The certified components are to be installed in a suitable housing that guarantees a protection class of at least IP54 in accordance with EN 60079-15! The environmental conditions during use are thereby to be taken into account!
- If the temperatures during rated operation are higher than 70°C at the feed-in points of cables, lines or pipes, or higher than 80°C at the wire branching points, then cables must be selected whose temperature data correspond to the actual measured temperature values!
- Observe the permissible ambient temperature range of 0 to 55°C for the use of Beckhoff fieldbus components standard temperature range in potentially explosive areas!
- Measures must be taken to protect against the rated operating voltage being exceeded by more than 40% due to short-term interference voltages!
- The individual terminals may only be unplugged or removed from the Bus Terminal system if the supply voltage has been switched off or if a non-explosive atmosphere is ensured!
- The connections of the certified components may only be connected or disconnected if the supply voltage has been switched off or if a non-explosive atmosphere is ensured!
- The fuses of the KL92xx/EL92xx power feed terminals may only be exchanged if the supply voltage has been switched off or if a non-explosive atmosphere is ensured!
- Address selectors and ID switches may only be adjusted if the supply voltage has been switched off or if a non-explosive atmosphere is ensured!

Standards

The fundamental health and safety requirements are fulfilled by compliance with the following standards:

- EN 60079-0:2012+A11:2013
- EN 60079-15:2010

Marking

The Beckhoff fieldbus components with standard temperature range certified according to the ATEX directive for potentially explosive areas bear one of the following markings:



II 3G KEMA 10ATEX0075 X Ex nA IIC T4 Gc Ta: 0 ... +55°C

or



II 3G KEMA 10ATEX0075 X Ex nC IIC T4 Gc Ta: 0 ... +55°C

3.5 ATEX - Special conditions (extended temperature range)

⚠ WARNING

Observe the special conditions for the intended use of Beckhoff fieldbus components with extended temperature range (ET) in potentially explosive areas (directive 2014/34/EU)!

- The certified components are to be installed in a suitable housing that guarantees a protection class of at least IP54 in accordance with EN 60079-15! The environmental conditions during use are thereby to be taken into account!
- If the temperatures during rated operation are higher than 70°C at the feed-in points of cables, lines or pipes, or higher than 80°C at the wire branching points, then cables must be selected whose temperature data correspond to the actual measured temperature values!
- Observe the permissible ambient temperature range of -25 to 60°C for the use of Beckhoff fieldbus components with extended temperature range (ET) in potentially explosive areas!
- Measures must be taken to protect against the rated operating voltage being exceeded by more than 40% due to short-term interference voltages!
- The individual terminals may only be unplugged or removed from the Bus Terminal system if the supply voltage has been switched off or if a non-explosive atmosphere is ensured!
- The connections of the certified components may only be connected or disconnected if the supply voltage has been switched off or if a non-explosive atmosphere is ensured!
- The fuses of the KL92xx/EL92xx power feed terminals may only be exchanged if the supply voltage has been switched off or if a non-explosive atmosphere is ensured!
- Address selectors and ID switches may only be adjusted if the supply voltage has been switched off or if a non-explosive atmosphere is ensured!

Standards

The fundamental health and safety requirements are fulfilled by compliance with the following standards:

- EN 60079-0:2012+A11:2013
- EN 60079-15:2010

Marking

The Beckhoff fieldbus components with extended temperature range (ET) certified according to the ATEX directive for potentially explosive areas bear the following marking:



II 3G KEMA 10ATEX0075 X Ex nA IIC T4 Gc Ta: -25 ... +60°C

or



II 3G KEMA 10ATEX0075 X Ex nC IIC T4 Gc Ta: -25 ... +60°C

3.6 Continulative documentation about explosion protection

● Explosion protection for terminal systems

i Pay also attention to the continuative documentation

Notes on the use of the Beckhoff terminal systems in hazardous areas according to ATEX and IECEx

that is available for [download](https://www.beckhoff.com) on the Beckhoff homepage <https://www.beckhoff.com>!

4 KS2000 Configuration software

4.1 KS2000 - Introduction

The KS2000 configuration software permits configuration, commissioning and parameterization of bus couplers, of the affiliated bus terminals and of Fieldbus Box Modules. The connection between bus coupler / Fieldbus Box Module and the PC is established by means of the serial configuration cable or the fieldbus.



Fig. 32: KS2000 configuration software

Configuration

You can configure the Fieldbus stations with the Configuration Software KS2000 offline. That means, setting up a terminal station with all settings on the couplers and terminals resp. the Fieldbus Box Modules can be prepared before the commissioning phase. Later on, this configuration can be transferred to the terminal station in the commissioning phase by means of a download. For documentation purposes, you are provided with the breakdown of the terminal station, a parts list of modules used and a list of the parameters you have modified. After an upload, existing fieldbus stations are at your disposal for further editing.

Parameterization

KS2000 offers simple access to the parameters of a fieldbus station: specific high-level dialogs are available for all bus couplers, all intelligent bus terminals and Fieldbus Box modules with the aid of which settings can be modified easily. Alternatively, you have full access to all internal registers of the bus couplers and intelligent terminals. Refer to the register description for the meanings of the registers.

Commissioning

The KS2000 software facilitates commissioning of machine components or their fieldbus stations: Configured settings can be transferred to the fieldbus modules by means of a download. After a *login* to the terminal station, it is possible to define settings in couplers, terminals and Fieldbus Box modules directly *online*. The same high-level dialogs and register access are available for this purpose as in the configuration phase.

The KS2000 offers access to the process images of the bus couplers and Fieldbus Box modules.

- Thus, the coupler's input and output images can be observed by monitoring.
- Process values can be specified in the output image for commissioning of the output modules.

All possibilities in the *online mode* can be used in parallel with the actual fieldbus mode of the terminal station. The fieldbus protocol always has the higher priority in this case.

5 Access from the user program

5.1 Examples of Register Communication

The numbering of the bytes in the examples corresponds to the display without word alignment.

5.1.1 Example 1: reading the firmware version from Register 9

Output Data

Byte 0: Control byte	Byte 1: DataOUT1, high byte	Byte 2: DataOUT1, low byte
0x89 (1000 1001 _{bin})	0xXX	0xXX

Explanation:

- Bit 0.7 set means: Register communication switched on.
- Bit 0.6 not set means: reading the register.
- Bits 0.5 to 0.0 specify the register number 9 with 00 1001_{bin}.
- The output data word (byte 1 and byte 2) has no meaning during read access. To change a register, write the required value into the output word.

Input Data (answer of the bus terminal)

Byte 0: Status byte	Byte 1: DataIN1, high byte	Byte 2: DataIN1, low byte
0x89	0x33	0x41

Explanation:

- The terminal returns the value of the control byte as a receipt in the status byte.
- The terminal returns the firmware version 0x3341 in the input data word (byte 1 and byte 2). This is to be interpreted as an ASCII code:
 - ASCII code 0x33 represents the digit 3
 - ASCII code 0x41 represents the letter A
 The firmware version is thus 3A.

5.1.2 Example 2: Writing to an user register



Code word

In normal mode all user registers are read-only with the exception of Register 31. In order to deactivate this write protection you must write the code word (0x1235) into Register 31. If a value other than 0x1235 is written into Register 31, write protection is reactivated. Please note that changes to a register only become effective after restarting the terminal (power-off/power-on).

I. Write the code word (0x1235) into Register 31.

Output Data

Byte 0: Control byte	Byte 1: DataOUT1, high byte	Byte 2: DataOUT1, low byte
0xDF (1101 1111 _{bin})	0x12	0x35

Explanation:

- Bit 0.7 set means: Register communication switched on.
- Bit 0.6 set means: writing to the register.

- Bits 0.5 to 0.0 specify the register number 31 with $01\ 1111_{\text{bin}}$.
- The output data word (byte 1 and byte 2) contains the code word (0x1235) for deactivating write protection.

Input Data (answer of the bus terminal)

Byte 0: Status byte	Byte 1: DataIN1, high byte	Byte 2: DataIN1, low byte
0x9F ($1001\ 1111_{\text{bin}}$)	0xXX	0xXX

Explanation:

- The terminal returns a value as a receipt in the status byte that differs only in bit 0.6 from the value of the control byte.
- The input data word (byte 1 and byte 2) is of no importance after the write access. Any values still displayed are invalid!

II. Read Register 31 (check the set code word)

Output Data

Byte 0: Control byte	Byte 1: DataOUT1, high byte	Byte 2: DataOUT1, low byte
0x9F ($1001\ 1111_{\text{bin}}$)	0xXX	0xXX

Explanation:

- Bit 0.7 set means: Register communication switched on.
- Bit 0.6 not set means: reading the register.
- Bits 0.5 to 0.0 specify the register number 31 with $01\ 1111_{\text{bin}}$.
- The output data word (byte 1 and byte 2) has no meaning during read access.

Input Data (answer of the bus terminal)

Byte 0: Status byte	Byte 1: DataIN1, high byte	Byte 2: DataIN1, low byte
0x9F ($1001\ 1111_{\text{bin}}$)	0x12	0x35

Explanation:

- The terminal returns the value of the control byte as a receipt in the status byte.
- The terminal returns the current value of the code word register in the input data word (byte 1 and byte 2).

III. Write to Register 32 (change contents of the feature register)

Output data

Byte 0: Control byte	Byte 1: DataIN1, high byte	Byte 2: DataIN1, low byte
0xE0 ($1110\ 0000_{\text{bin}}$)	0x00	0x02

Explanation:

- Bit 0.7 set means: Register communication switched on.
- Bit 0.6 set means: writing to the register.
- Bits 0.5 to 0.0 indicate register number 32 with $10\ 0000_{\text{bin}}$.
- The output data word (byte 1 and byte 2) contains the new value for the feature register.

⚠ CAUTION

Observe the register description!

The value of 0x0002 given here is just an example!

The bits of the feature register change the properties of the terminal and have a different meaning, depending on the type of terminal. Refer to the description of the feature register of your terminal (chapter *Register description*) regarding the meaning of the individual bits before changing the values.

Input data (response from the Bus Terminal)

Byte 0: Status byte	Byte 1: DataIN1, high byte	Byte 2: DataIN1, low byte
0xA0 (1010 0000 _{bin})	0xXX	0xXX

Explanation:

- The terminal returns a value as a receipt in the status byte that differs only in bit 0.6 from the value of the control byte.
- The input data word (byte 1 and byte 2) is of no importance after the write access. Any values still displayed are invalid!

IV. Read Register 32 (check changed feature register)

Output Data

Byte 0: Control byte	Byte 1: DataOUT1, high byte	Byte 2: DataOUT1, low byte
0xA0 (1010 0000 _{bin})	0xXX	0xXX

Explanation:

- Bit 0.7 set means: Register communication switched on.
- Bit 0.6 not set means: reading the register.
- Bits 0.5 to 0.0 indicate register number 32 with 10 0000_{bin}.
- The output data word (byte 1 and byte 2) has no meaning during read access.

Input Data (answer of the bus terminal)

Byte 0: Status byte	Byte 1: DataIN1, high byte	Byte 2: DataIN1, low byte
0xA0 (1010 0000 _{bin})	0x00	0x02

Explanation:

- The terminal returns the value of the control byte as a receipt in the status byte.
- The terminal returns the current value of the feature register in the input data word (byte 1 and byte 2).

V. Write Register 31 (reset code word)

Output Data

Byte 0: Control byte	Byte 1: DataOUT1, high byte	Byte 2: DataOUT1, low byte
0xDF (1101 1111 _{bin})	0x00	0x00

Explanation:

- Bit 0.7 set means: Register communication switched on.
- Bit 0.6 set means: writing to the register.
- Bits 0.5 to 0.0 specify the register number 31 with 01 1111_{bin}.
- The output data word (byte 1 and byte 2) contains 0x0000 for reactivating write protection.

Input Data (answer of the bus terminal)

Byte 0: Status byte	Byte 1: DataIN1, high byte	Byte 2: DataIN1, low byte
0x9F (1001 1111 _{bin})	0xXX	0xXX

Explanation:

- The terminal returns a value as a receipt in the status byte that differs only in bit 0.6 from the value of the control byte.
- The input data word (byte 1 and byte 2) is of no importance after the write access. Any values still displayed are invalid!

6 TwinCAT

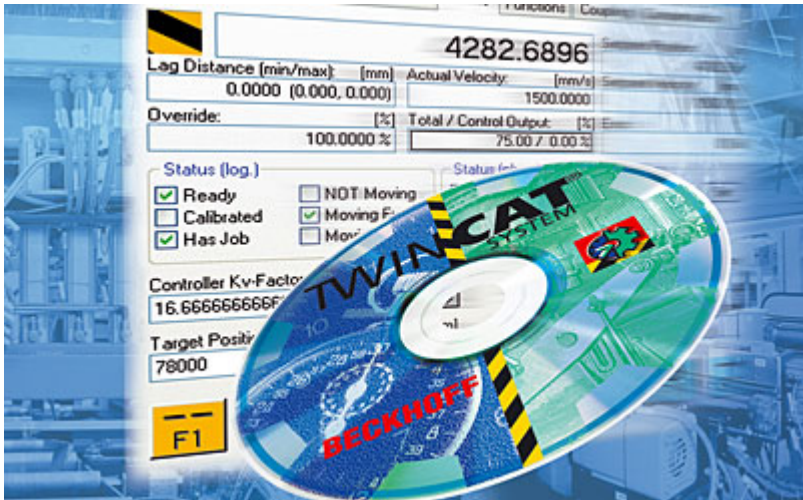

PLC and Motion Control on the PC

TwinCAT - The **Windows Control and Automation Technology**

The TwinCAT automation software converts any compatible PC into a real-time controller with multi-PLC, NC axis control, programming environment and operating station. TwinCAT replaces conventional PLC and NC controllers as well as operating devices:

- open, compatible PC hardware
- Embedding of IEC 61131-3 software PLC, software NC and software CNC in Windows NT/2000/XP, NT/XP Embedded, CE
- Programming and runtime systems optionally together on one PC or separated
- Connection to all common fieldbus systems
- PC interfaces are supported
- Data communication with user interfaces and other programs by means of open Microsoft standards (OPC, OCX, DLL, etc.)

TwinCAT architecture

TwinCAT consists of runtime systems for real-time execution of control programs and development environments for programming, diagnosis and configuration. Any Windows programs, for instance visualization programs or Office programs, can access TwinCAT data via Microsoft interfaces, or can execute commands.

A practically oriented software solution

TwinCAT offers a precise time-base in which programs are executed with the highest deterministic features, independently of other processor tasks. The real-time load on a PC is set with TwinCAT: This achieves a defined operating behavior. TwinCAT displays the system load for running programs. A loading threshold can be set, in order to assure a defined computing capacity for the operating programs and for Windows NT/2000/XP. If this threshold is exceeded, a system message is generated.

TwinCAT supports system diagnosis

The general use of hardware and software from the open PC world requires some checking: Unsuitable components can upset the PC system. Beckhoff integrates a handy display of the real-time jitter in order to provide administrators with a simple means of evaluating hardware and software. A system message during operation can draw attention to error states.

Start/stop behavior

Depending on the setting, TwinCAT is started and stopped manually or automatically. Since TwinCAT is integrated into Windows NT/2000/XP as a service, an operator is not needed to start the system: switching on is enough.

Restarting and data backup

When a program is started or restarted, TwinCAT loads programs and remanent data. To backup data, and to shut down Windows NT/2000/XP correctly, a UPS (uninterruptible power supply) is of great value.

TwinCAT and "Blue Screen"

The TwinCAT system can be configured such that real-time capability is maintained in the event of a BSOD (Blue-Screen-of-Death) operating system crash. Real-time tasks such as PLC and NC can thus continue to run and place the controlled process in a safe state. Ultimately, it is the decision of the programmer whether or not to utilize this feature, bearing in mind that data or programs may already have been destroyed by the BSOD.

World-wide connection through message routing - "remote" connection is inherent to the system

According to the requirement for operating resources, the TwinCAT software devices can be distributed: TwinCAT PLC programs can be executed on PCs and on Beckhoff Bus Terminal controllers. A "message router" manages and distributes all the messages, both in the system and via TCP/IP connections. PC systems can be connected to one another by TCP/IP; Bus Terminal controllers are connected via serial interfaces and fieldbus systems (EtherCAT, Lightbus, PROFIBUS DP, PROFINET, Interbus, CANopen, DeviceNet, RS232, RS485, Ethernet TCP/IP, Ethernet/IP).

World-wide access

Since standard TCP/IP services from Windows NT/2000/XP are used, this data exchange can take place worldwide. The system offers scalable communication capacity and timeout periods for the monitoring of communications. OPC provides a standardized means for accessing many different SCADA packets. The SOAP (Simple Object Access Protocol) enables a connection between two computers to be established by means of an internet connection via standard HTTP. A TwinCAT component is available for this purpose.

Beckhoff Information System

Further information on the TwinCAT automation software can be found in the Beckhoff Information System.

The setup for installing the Beckhoff Information System is available to you on the Beckhoff *Products & Solutions* DVD and on our website for [download](#).

In addition, the online version of the Beckhoff Information System can be found at <https://infosys.beckhoff.com>.

6.1 Programming

TwinCAT libraries

See software documentation in the Beckhoff Information System.

TwinCAT 2: TwinCAT PLC Lib: [I/O functions](#)

TwinCAT 3: TwinCAT 3 PLC Lib: [Tc2_IoFunctions](#)

7 Appendix

7.1 Support and Service

Beckhoff and their partners around the world offer comprehensive support and service, making available fast and competent assistance with all questions related to Beckhoff products and system solutions.

Beckhoff's branch offices and representatives

Please contact your Beckhoff branch office or representative for [local support and service](#) on Beckhoff products!

The addresses of Beckhoff's branch offices and representatives round the world can be found on her internet pages:

<http://www.beckhoff.com>

You will also find further [documentation](#) for Beckhoff components there.

Beckhoff Headquarters

Beckhoff Automation GmbH & Co. KG

Huelshorstweg 20
33415 Verl
Germany

Phone: +49 5246 963 0
Fax: +49 5246 963 198
e-mail: info@beckhoff.com

Beckhoff Support

Support offers you comprehensive technical assistance, helping you not only with the application of individual Beckhoff products, but also with other, wide-ranging services:

- support
- design, programming and commissioning of complex automation systems
- and extensive training program for Beckhoff system components

Hotline: +49 5246 963 157
Fax: +49 5246 963 9157
e-mail: support@beckhoff.com

Beckhoff Service

The Beckhoff Service Center supports you in all matters of after-sales service:

- on-site service
- repair service
- spare parts service
- hotline service

Hotline: +49 5246 963 460
Fax: +49 5246 963 479
e-mail: service@beckhoff.com

List of illustrations

Fig. 1	KL1002	9
Fig. 2	KL1012	9
Fig. 3	KL1002	11
Fig. 4	KL1012	12
Fig. 5	KL1104	13
Fig. 6	KL1114	13
Fig. 7	KL1104	15
Fig. 8	KL1402	16
Fig. 9	KL1412	16
Fig. 10	KL1402	18
Fig. 11	KL1404	19
Fig. 12	KL1414	19
Fig. 13	KL1434	20
Fig. 14	KL1414	22
Fig. 15	KL1434	23
Fig. 16	KL1408	24
Fig. 17	KL1418	24
Fig. 18	KL1488	25
Fig. 19	KL1498	25
Fig. 20	KL1408	27
Fig. 21	KL1488	28
Fig. 22	KL1862	29
Fig. 23	KL1872	29
Fig. 24	KL1862	31
Fig. 25	Attaching on mounting rail	32
Fig. 26	Disassembling of terminal.....	33
Fig. 27	Power contact on left side.....	34
Fig. 28	Standard wiring.....	36
Fig. 29	Pluggable wiring	36
Fig. 30	High Density Terminals.....	37
Fig. 31	Connecting a cable on a terminal point	38
Fig. 32	KS2000 configuration software.....	43