

OPERATOR'S MANUAL

DUAL INPUT K/J THERMOMETER

802

802U USB & DC Power

802WE Wireless

802UWE USB & DC Power & Wireless

802W Wireless FCC ID:VEARF915

802UW USB & DC Power & Wireless

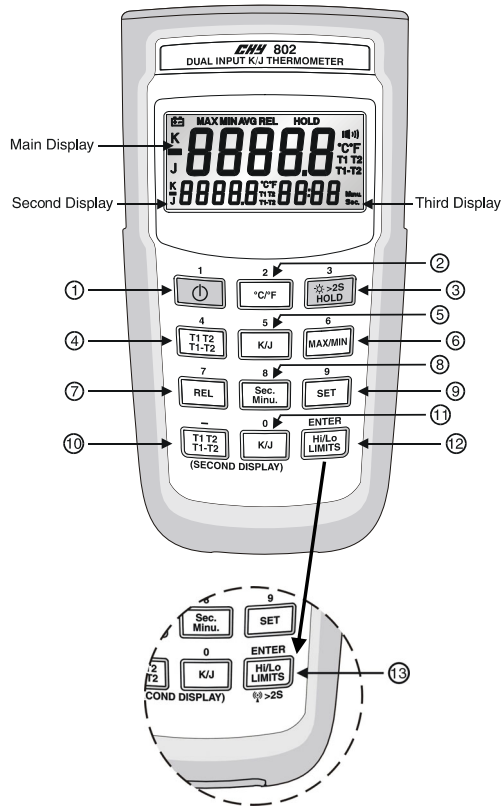

(802W/802UW/802WE/802UWE)

INTRODUCTION

This instrument is a 5 digit, compact-sized portable digital thermometer designed to use external K-type and J type thermocouples as temperature sensor. Temperature indication follows Reference Temperature/Voltage Tables (N.I.S.T. Monograph 175 Revised to ITS-90) for K-type and J-type thermocouples. Two K-type thermocouple are supplied with the thermometer.

SAFETY INFORMATION

It is recommended that you read the safety and operation instructions before using the thermometer.

WARNING

To avoid electrical shock, do not use this instrument when working voltages at the measurement surface over 24V AC or DC.

WARNING

To avoid damage or burns, do not make temperature measurement in microwave ovens.

CAUTION

Repeated sharp flexing can break the thermocouple leads. To prolong lead life, avoid sharp bends in the leads, especially near the connector.

FEDERAL COMMUNICATIONS COMMISSION

This device complies with Part 15 of the FCC Rules. Operation is subject to the following two conditions: (1) this device may not cause harmful interference, and (2) this device must accept any interference received, including interference that may cause undesired operation.

NOTE

This equipment has been tested and found to comply with the limits for a Class B digital device, pursuant to Part 15 of the FCC Rules. These limits are designed to provide reasonable protection. This equipment generates, uses and can radiate radio frequency energy and, if not installed and used in accordance with the instructions, may cause harmful interference to radio communications. However, there is no guarantee that interference will not occur in a particular installation. If this equipment does cause harmful interference to radio or television reception, which can be determined by turning the equipment off and on, the user is encouraged to try to correct the interference by one or more of the following measures:

- Reorient or relocate the receiving antenna.
- Increase the separation between the equipment and receiver.
- Connect the equipment into an outlet on a circuit different from that to which the receiver is connect-

ed.

- Consult the dealer or an experienced radio/TV technician for help.

Shielded interface cables must be used in order to comply with emission limits.

Changes or modifications not expressly approved by the party responsible for compliance could void the user's authority to operate the equipment.

WIRELESS NOTE

Wireless receiver must keep a distance at least 40cm from the meter and meter to meter distance must be at least 30cm.

SPECIFICATIONS

ELECTRICAL

Temperature Scale: Celsius or Fahrenheit user-selectable.

Measurement Range:

J-TYPE -200°C to 1050°C, (-328°F to 1922°F)

K-TYPE -200°C to 1370°C, (-328°F to 2498°F)

Resolution: 0.1°C or 0.2°F

Accuracy: Accuracy is specified for operating temperatures over the range of 18°C to 28°C (64°F to 82°F), for 1 year, not including thermocouple error.

±(0.05% rdg + 0.3°C) -50°C to 1370°C

±(0.05% rdg + 0.7°C) -50°C to -200°C

±(0.05% rdg + 0.6°F) -58°F to 2498°F

±(0.05% rdg + 1.4°F) -58°F to -328°F

Temperature Coefficient:

0.1 times the applicable accuracy specification per °C from 0°C to 18°C and 28°C to 50°C (32°F to 64°F and 82°F to 122°F).

Input Protection:

24V dc or 24V ac rms maximum input voltage on any combination of input pins.

Maximum Differential Common Mode Voltage (Maximum Voltage between T1 and T2 during measurement): 1volt.

Input Connector: Accepts standard miniature thermocouple connectors (flat blades spaced 7.9mm, center to center).

GENERAL

Display: 5 digit liquid crystal display (LCD).

Overload: "----." or "OL" is display.

Battery: 1.5V x 4 PCS (SIZE AAA) UM-4 R03.

Battery Life: 190 hours typical with carbon zinc battery.

Reading Rate: 1 time per second.

Auto power off: 30 minutes, press power key to resume operation.

Dimensions: 160mm(H) x 83mm(W) x 38mm(D)

Weight: Approx. 270g including batteries.

Supplied Wire: 4 feet type "K" thermocouple bead wire (Teflon tape insulated). Maximum insulation temperature 260°C (500°F). Wire accuracy ±2.2°C or ±0.75% of reading (whichever is greater) from 0°C to 800°C.

Wire Communication Protocol:

19200 baud rate. (802U/802UW/802UWE)

Back Side: (802U/802UW/802UWE)

1. USB Port

2. DC power JACK(12V)

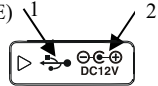

ENVIRONMENTAL

Ambient Operating Ranges:

0°C to 50°C (32°F to 122°F) <70% R.H.

Storage Temperature:

-20°C to 60°C (-4°F to 140°F) <80% R.H.

Wireless Features:

Frequency range: 910~920MHz (802W/802UW)

868.1~868.5MHz (802WE/802UWE)

Low current consumption less than 1mA.

The transmitting distance can reach 25M without magnetic interference.

OPERATING INSTRUCTIONS

1. "⏻" Power Switch

The "⏻" key turns the thermometer on or off. In the SET mode cannot be powered off. Exit SET mode to power off.

APO function mode

Press "⏻" power key for more than 6 seconds to disable the auto-power function. The display will show "APO OFF".

2. "°C/°F" Selecting the Temperature Scale

Readings are displayed in either degrees Celsius(°C) or degrees Fahrenheit(°F). When the thermometer is turned on, it is set to the temperature scale that was in use when the thermometer was last turned off. To change the temperature scale, press the "°C/°F" key.

3. "*2S HOLD" Mode (only Main display)

Press this key to enter the Data Hold mode, the "HOLD" annunciator is displayed. When HOLD mode is selected, the thermometer holds the present readings and stops all further measurements. Press the "*2S HOLD" key again to cancel HOLD mode and resume measurements. In the MAX/MIN recording mode, press "*2S HOLD" key to stop the recording. Press "*2S HOLD" key again to resume recording. (Previously recorded readings are not erased).

Backlight function mode

Press the "*2S HOLD" key for more than two seconds to turn on the backlight. Press the key again for more than two seconds to turn off the backlight. The backlight will switch-off automatically after 30 seconds.

4. “T1 T2/T1-T2” Main Display Input Selection

The input selection indicates which input is selected for main display; T1 thermocouple, T2 thermocouple or the difference between the two thermocouples (T1-T2), when the thermometer is turned on, it is set to T1.

5. “K/J” Main display Input Thermocouple Type Select

The “K/J” key selects the T1 thermocouple type, when the main display is showing T1. When the thermometer is turned on, it is set to the type selected when the thermometer was last turned off.

6. “MAX/MIN” With Time Record Mode (only Main display)

Press “MAX/MIN” key to enter the MAX MIN Recording mode, (displays the Maximum reading with time, Minimum reading with time and Average reading stored in record mode). In this mode the automatic power-off feature is disabled and “ \odot ” key, “°C/°F” key, “REL” key, “SET” key, “Hi/Lo LIMITS” key and main display “T1 T2 T1-T2” key, “K/J” key are disabled. The beeper emits a tone when a new minimum or maximum value is recorded.

Press “MAX/MIN” key to cycle through the MAX, MIN and AVG readings. If an overload is recorded, the averaging function is stopped. In this mode, press the “HOLD” key to stop the recording of readings, all values are held, press again to restart recording.

To prevent accidental loss of MAX, MIN and AVG data, this mode can only be cancelled by pressing and holding the “MAX/MIN” key for 2 seconds. All recorded readings are erased.

7. “REL” Relative Mode (only Main display)

Press the “REL” key to enter the relative mode, zero the display, and store the displayed Reading as a reference value. REL is shown on the display. Press “REL” key again to exit the relative mode. The relative reference value can also be entered by the user. (See “SET mode” later in this manual). When the desired relative value has been entered, press “REL” key to enter the relative mode and then press “SET” key use the entered relative value as a reference value. Press “REL” key again to exit the relative mode. In the relative mode, the value (can not $\geq \pm 3000.0$ counts) shown on the LCD is always the difference between the stored reference and the present reading.

8. “Sec. Minu.” Selecting the Time scale

Press this key to display the elapsed time on the third display in either hours and minutes or minutes and seconds. When the thermometer is turned on, it is set to seconds. To change the time scale, press “Sec. Minus.” key. Maximum elapsed time reading is 100 hours. If 100 hours is exceeded, the elapsed time resets to zero.

9. “SET” Mode (Relative value set, Time set and Hi/Lo Limits value set)

9.1 Press the “SET” key to enter relative values SET mode (Press “ENTER” key to skip setting relative value). “= = = =” is displayed on the main display. The relative value is entered via overlay numbers, press overlay “ENTER” key to store the relative value, and advance to elapsed time set mode.

9.2 Elapsed time set mode, (Press “ENTER” key to skip Elapsed time set mode) “= = = = : = =” is displayed in second and third display. Time (hours, minutes, seconds) value is entered via overlay numbers, press overlay “ENTER” key to store time value. Elapsed time starts from set time value.

9.3 Hi Limit value set mode, “ \blacksquare ” is displayed (Press “ENTER” key to skip Hi Limit value set mode), “= = = =” is displayed in main display, Hi Limit value is entered via overlay numbers, then press “ENTER” key to store the Hi Limit value. “= = = =” is displayed in main display, Lo Limit value is entered via overlay numbers, then press overlay “ENTER” key to store the Lo Limit value and exit SET mode.

9.4 When the thermometer is turned on it uses the relative value and Hi/Lo Limits values that were entered when thermometer was last in use.

10. “T1 T2 T1-T2” Second display Input Selection

The input selection indicates which input is selected for second display; T1 thermocouple, T2 thermocouple or the difference between the two thermocouples (T1-T2). When the thermometer is turned on, it is set to T2 input. To select a different type of thermocouple use the “K/J” key.

11. “K/J” Second display Input thermocouple type select

The “K/J” key for T2 input selects K-type or J-type thermocouple as input, when the second display has T2 shown. When the thermometer is turned on, it is set to the type selected when the thermometer was last turned off.

12. “Hi/Lo LIMITS” Mode (only Main display)

Press “Hi/Lo LIMITS” key to enter the Hi/Lo Limits comparative mode, “ \blacksquare ” is displayed. When the input temperature value exceeds the Hi or Lo Limits value, the beeper emits a continuous or pulsed tone. Press “Hi/Lo LIMITS” key again to exit the Hi/Lo Limits mode.

13. WIRELESS MODE: (802W/802UW/802WE/802UWE)

Press the “ \odot ” key for more than two seconds to start wireless function. Press the “ \odot ” key again for another two seconds to stop wireless function. The wireless mode will shut down if there is no wireless signal for two minutes.

To SET CH/ID to 00,00, press the “Hi/Lo LIMITS” key and “ \odot ” power key for more than 6 seconds with the meter powered down. The meter will set channel and ID to 00,00 status. The second display will show 00, which means that the channel and ID has been set to 00.

To check the channel and ID of the meter:

When the meter is off, press “°C/°F” key and “ \odot ” for 5 seconds, LCD’s main display will show channel number, the second display will show ID number.

MAINTENANCE

WARNING

To avoid possible electrical shock, disconnect the thermocouple connectors from the thermometer before removing the cover.

Installing and Replacing Battery

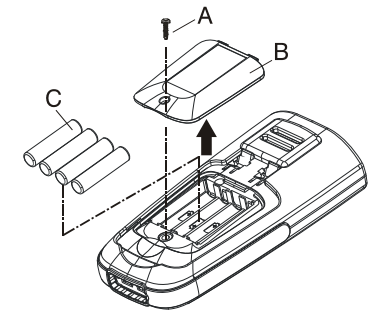

- A. Screw
- B. Battery Cover
- C. Battery

1. Power is supplied by 4pcs 1.5V (SIZE AAA) UM-4 R03.
2. The “ \oplus ” appears on the LCD display when replacement is needed. To replace battery remove screw from back of meter and lift off the battery cover.
3. Remove the battery from battery contacts and replace.
4. When not use for long time remove battery.
5. Don’t keep in place with high Temp, or high humidity.

Cleaning

Periodically wipe the case with a damp cloth and detergent, do not use abrasives or solvents.

*Software download link:

http://www.chy-meter.com//data/outer_web/1492-0800UW/1492-0800UW-301.zip