

# OPERATOR'S MANUAL

## MODEL 261

### HYGRO-ANEMOMETER

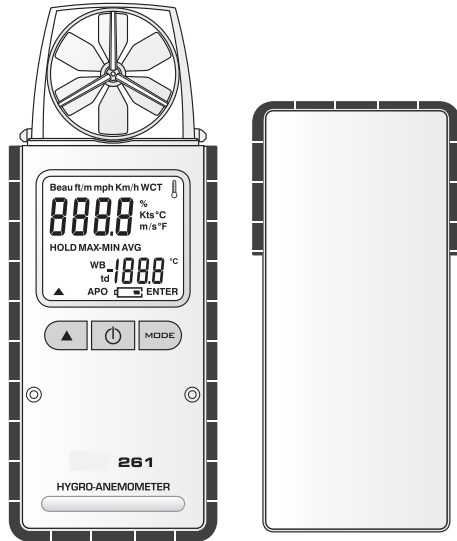

## SPECIFICATIONS

### WIND VELOCITY

**Range:** 0.4 to 20 m/s, 80 to 4000ft/m  
**Accuracy:** ±0.2m/s + 2% of reading,  
 ±40ft/m + 2% of reading  
**Resolution:** 0.1m/s, 1ft/m

### RELATIVE HUMIDITY

**Sensor:** Digital Capacitive humidity sensor  
**Range:** 0% to 100% RH  
**Accuracy:**  
 ±2.5% at 25°C(77°F), 10% to 90% RH  
 ±5% at 25°C(77°F), 0% to 10% RH, 90% to 100% RH  
**Sensor Response Time for 90% of Total Range:**  
 60sec typical.  
**Sensor Hysteresis(excursion of 10% to 90% to 10% RH):** ±1%RH typical.

### AIR TEMPERATURE

**Range:** -20°C to 60°C, -4°F to 140°F  
**Accuracy:**  
 ±0.5°C for 0°C to 45°C  
 ±1.0°C for -20°C to 0°C, 45°C to 60°C  
 ±1.0°F for 32°F to 113°F  
 ±2.0°F for -4°F to 32°F, 113°F to 140°F  
**Resolution:** 0.1°C, 0.1°F  
**Accuracy:** Stated accuracy at 18°C to 28°C(64°F to 82°F),  
 <75% R.H.

**Temperature Coefficient:** 0.1 times the applicable accuracy specification per °C out of 18°C to 28°C(64°F to 82°F).

**Measurement rate:** 1 times/second

**Operating environment:** 0°C to 50°C(32°F to 122°F) at <70% R.H.

**Storage temperature:** -20°C to 60°C(-4°F to 140°F), 0 to 80% R.H. with battery removed from meter.

**Battery:** 1.5Vx2pcs AAA size.

**Battery Life:** 50 hours typical with alkaline battery.

**Low battery indication:** The "⏻" is displayed when the battery voltage drops below the operating level.

**Dimensions:** 24.7mm(T) x 50.9mm(W) x 132.9mm(H).

**Weight:** Approx. 119g including batteries.

## OPERATIONS

There are 3 operation modes, namely Measurement Mode, Set Mode and MAX/MIN Mode.

### 1. Turning on and off the meter:

When power is off, a short push on "⏻" key turns on the meter and enter Measurement Mode. When power is on, press and hold "⏻" key for 2 seconds turns the power off.

Right after power on, all the indicators on the LCD display lights up for one second.

### 2. Measurement Mode:

After power on, face the back side (where battery cover is) of the meter to the air flow, the measurement reading refreshed every second.

Push the "▲" key scroll the reading through air speed, relative humidity and Wind Chill Temperature (WCT).

**Note:** When power is turn off the display setting (either air speed, relative humidity or WCT) at that moment will be saved and remains unchanged when the meter is turned on next time.

### Backlight:

In measurement mode, a short push on "⏻" key turns on the backlight for dark environment, it goes off automatically after 15 seconds if without further operation.

### 3. Set Mode:

In set mode, user can turn on/off APO function, select unit of temperature and select unit of velocity and select humidity or wet-bulb temperature (WB) measurement. (APO = Auto Power Off, when APO is ON, the meter power off automatically if no operation in 10 minutes) When power is off, press and hold "⏻" key for 2 seconds to enter Set Mode.

In Set Mode, press "Mode" key each time move settable position in following sequence (indicator of settable position blinks.)

3.1 Unit of velocity: Short push on "▲" key scroll unit of velocity (m/s, Km/h, ft/m, mph, kts, Beau). Push "Mode" key to select the unit of velocity and enter selection unit of temperature.

3.2 Unit of temperature: short push on "▲" key scroll units of temperature(°C, °F). Push "Mode" key to select the unit of temperature and enter selection of humidity td or WB measurement.

3.3 Selection of humidity td or WB measurement: short push on "▲" key to change the measurement through humidity (%), td, and WB. Push "Mode" key to select and enter APO ON/OFF setting.

3.4 APO ON/OFF: short push on "▲" key switches between ON and OFF. Push "Mode" key to select and exit Set Mode and Entering Measurement Mode.  
 (Please refer to the section of Measurement Mode.)

※**Note:** To turn off power in Set Mode abandon the current setting and previous settings remain unchanged. If "⏻" indicator appeared, the setting value can works till power off but did not save to meter.

### 4. MAX/MIN Mode:

In Measurement Mode, short push "Mode" key to enter MAX/MIN MODE.

Push "Mode" key each time the display changes in following sequence:

- 4.1 Last Measurement: with indicator "HOLD".
- 4.2 Maximum value recorded: with indicator "MAX".
- 4.3 Minimum value recorded: with indicator "MIN".
- 4.4 Maximum-Minimum value recorded: with indicator "MAX-MIN".
- 4.5 Average of values recorded: with indicator "AVG".
- 4.6 Exit the MAX/MIN MODE and return to Measurement Mode.

### To clear the recorded values:

In MAX/MIN MODE and during viewing MAX, MIN, MAX-MIN or AVG, press and hold "Mode" key for 2 seconds, to clear the recorded data and return to measurement mode.

## MAINTENANCE

### Installing and Replacing Battery

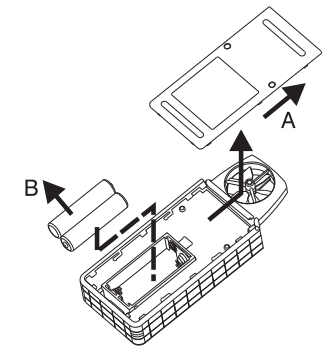

- A. Battery Cover  
 B. Battery

1. Power is supplied by 2pcs 1.5V (AAA SIZE).
2. The "⏻" appears in the display when battery replacement is needed.
3. Push the Battery Cover and lift it in the direction as shown in the figure.
4. Remove the batteries from battery compartment.
5. Replace with 2 new AAA batteries with polarity as indicated on the bottom of Battery Compartment.
6. Replace the Battery Cover.

### Cleaning

Periodically wipe the case with a damp cloth and detergent, do not use abrasives or solvents.

## INTRODUCTION

This instrument vane type air speed meter. When air flows through the meter, turns the vane air speed is measured. The measurement air speed is shown at upper display, while environment temperature is shown at lower display.

## SAFETY INFORMATION

It is recommended that you read the safety and operation instructions before using the hygro-anemometer.

1. Only operate the measuring instrument properly, for its intended purpose and within the parameters specified. Do not use force.
2. Never store the product together with solvents, acids or other aggressive substances.
3. Don't keep in place with high Temp, or high humidity.