

# USER MANUAL

# 8400K

## Optical Micrometer Kit



**JCHADWICK**  
Innovative Inspection Solutions

# 8400K: Kit Contents

The 11 piece kit includes interchangeable optics and bases for different applications and a Scratch Sample Plate for training. The entire kit fits in a portable case and weighs less than 7 lbs.



## Standard Items:

P/N	Item Description
1	8400-0 Optical Micrometer <i>(shown with eyepiece, objective and base installed)</i>
2	8400-7 Base, 3-Leg
3	8400-8 Base, 4-Leg
4	8400-91 Base, Clear Acrylic V-Block
5	8400-14 Eyepiece, 20X
6	8400-15 Eyepiece, 10X w/ Reticule Scale
7	8400-16 Objective Lens, 10X
8	8400-17 Objective Lens, 4X
9	8400-23 LED Flashlight w/ Adapter Tip
10	8400-25 Case
11	8400-32 Scratch Sample Plate

## Optional Items:

P/N	Item Description
8400-12	Base, 3-Leg Offset
8400-7-1	Base, 3-Leg, Delrin Tip
8400-27	Base, 3-Leg, Large
8400-35	Base, 2-Leg



# Interchangeable Parts

Both the eyepiece and the objective lens can be removed and replaced for levels of magnification from 40X to 200X. Bases can be swapped to accommodate different surfaces.

---

To remove a base, firmly hold the Micrometer barrel and turn the base counter-clockwise until the threads disengage. To replace, select desired base and thread onto the Micrometer body in a clockwise direction. **DO NOT OVER-TIGHTEN.**

---

The **tripod base** is recommended for flat surfaces.

The **quadpod base** is recommended for simple curved surfaces.

The **transparent V-block base** is recommended for small diameters, outside angles and flat surfaces near a recess.

Four additional bases are available, please call for price and availability.

- An **offset base** for measurements along edges.
- A **delrin-tipped tripod base** for delicate finishes.
- A **large tripod base** for parts inspection.
- A **wedge bipod base** for corners and inside angles.

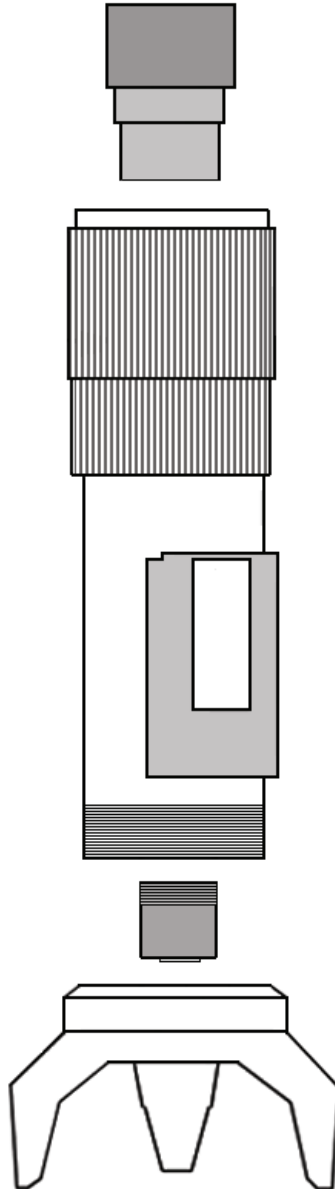

The eyepiece can be removed by grasping with thumb and forefinger and sliding in or out of the eyepiece sleeve. Care should be taken to avoid dirt or moisture entering the tube when removing eyepiece.

A 10X reticle eyepiece enables visual width measurements. **Width observations are valid only at 100X magnification (10X Reticle Eyepiece with 10X Objective Lens).**

---

To change the objective lens, turn the focus adjustment clockwise until the threads of the objective lens are visible at the base of the Micrometer. Holding the Micrometer body firmly, grasp objective lens and turn counter-clockwise until threads disengage.

---

**100X and 200X magnification** is recommended for inspecting scratch depth, scribe lines, blind holes, corrosion pits, spurs and other very small protrusions or indentations.

**40X and 80X magnification** is recommended for inspecting transparent materials for overall thickness and the depth of fractures and imbedded bubbles or "seeds".

# Operation: Taking Measurements

The Micrometer features a very shallow depth of focus that allows the distance between two points at different depths to be easily measured. Areas within the focal plane will appear sharp while areas above and below this plane will be out of focus.

The Micrometer does not feature prismatic correction, so the image is inverted.

## • Step 1

Shine flashlight through the eyepiece to create a pin-point spot. Use spot to position Micrometer directly over region of interest (ROI).

## • Step 2

Without moving the Micrometer, place lit flashlight in desired flashlight receptacle on base.

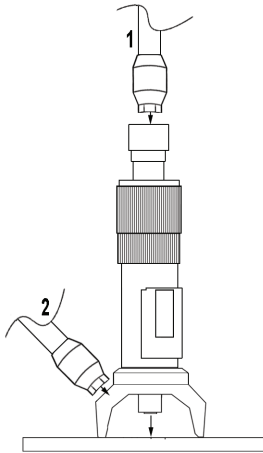

Hold the base of micrometer for support while focusing to prevent it from moving.

## • Step 3

Look through the eyepiece and use the focus adjustment to bring the primary surface (the undamaged surface directly next to the scratch or pit, "Surface A" in diagram at right) into sharp focus.

At 100X magnification, the objective lens will be approximately 1/4" over the target when in focus.

## • Step 4

Press the "ZERO/ABS" button (display should now read "0.0000").

## • Step 5

Focus into the bottom of damaged area ("Surface B" in diagram below).

## • Step 6

Record depth shown on digital display.

## • Step 7

This step is for verification only. Re-focus on the top surface, display should show "0.0000".

## • Step 8

Repeat steps 3-7 for verification.

## Transparencies

For transparent materials it is necessary to know the refraction index of the specific material. The Micrometer reading must be multiplied by the refraction index for an accurate result.

For instance, if measuring the overall thickness of a plexiglass window and the Micrometer reads 0.3600", the actual thickness of the window is 0.3600 x 1.49 (the refractive index of plexiglass), or 0.5364".

Bubbles inside transparent materials are air space and not subject to the refraction index.

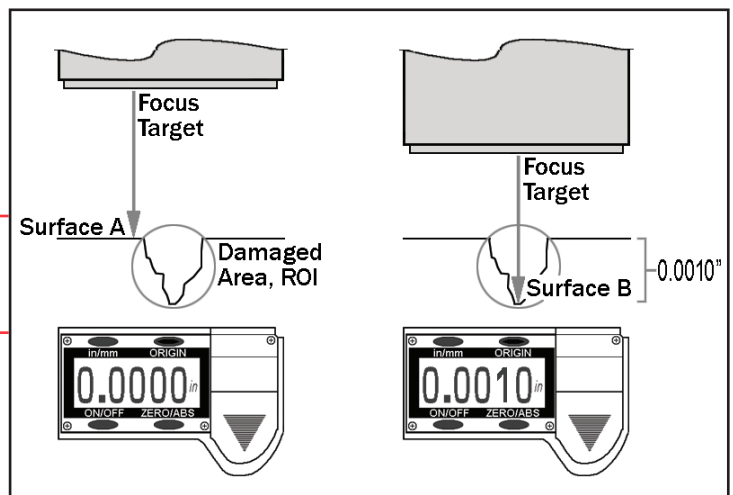

# Specifications

## • DIMENSIONS & WEIGHT

### 8400K KIT IN CASE

16" x 7" x 5", 5 LBS

### 8400-0 MICROMETER ONLY

9" HEIGHT, 2" DIA STEM, 3" DIA BASE, 1.5 LBS

## • ACCURACY & RESOLUTION

In inches, the digital readout shows 4 decimal places; "0.0000". The far right (ten-thousandths) rounds-off and reads "0" or "5" (0.0000 or 0.0005).

In millimeters, the readout shows 2 decimal places; "0.00". The far right (hundredth-mm) place reads in 0.01 mm increments.

**ACCURACY +/- 0.001" / 0.02mm**

**RESOLUTION 0.0005" / 0.01 mm**

## • RANGE

### 10X OBJECTIVE LENS

Vertical range (or depth) **0.250"** (6.4mm) from surface to bottom of scratch.

Width of 0.040" (0.02mm) can be visually measured with the reticle eyepiece.

**Width observations are valid only at 100X magnification (10X Reticle Eyepiece with 10X Objective Lens).**

### 4X OBJECTIVE LENS

Vertical range (or depth) **1.250"** (32mm) from surface to bottom of scratch.

## • TEMPERATURES

### OPERATING

0°C to 40°C / 32°F to 140°F

### STORAGE

-10°C to 60°C / 14°F to 140°F

# Calibration

Recommended Calibration Cycle: **1 Year**

## A. EQUIPMENT

Gage blocks, calibrated and traceable to NIST.  
Sizes: 0.0625, 0.1000", 0.1250", 0.2000"

## B. INSTRUCTIONS

### • Step 1

Wring **0.1000"** and **0.0625"** gage blocks together by sliding one block across the top of another, creating a step (see diagram below).

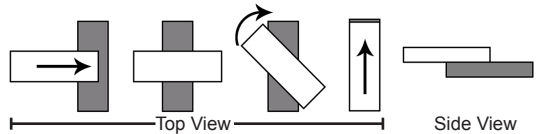

### • Step 2

Place micrometer over the step created by the two blocks. Position so approximately one half of the field of view is on the upper block. (See diagram below.)

### • Step 3

Focus on the surface of the **upper** block (**1** in diagram below).

### • Step 4

Set **Zero** "0.0000" on digital display.

### • Step 5

Focus on **lower** block (**2** in diagram below).

### • Step 6

Read display; if equipment is functioning properly the display will show thickness of **upper** block.

### • Step 7

Repeat steps 1-5, using the **0.1250"** and **0.2000"** gage blocks.

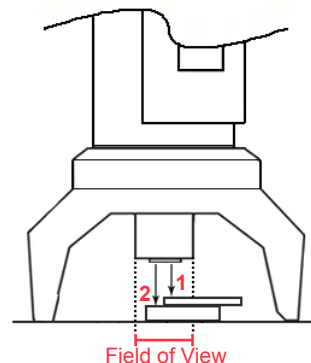

# Warranty

John Chadwick Corporation DBA **J Chadwick Co** warrants the 8400K Digital Optical Micrometer Kit, herein referred to as **the product**, against defects in material or workmanship as follows;

## LABOR

For a Period of two (2) years from the purchase date, if **the product** is determined to be defective, **J Chadwick Co** will repair **the product** at no charge to the buyer. If **the product** is determined by **J Chadwick Co** to be defective beyond repair, a replacement will be provided.

## PARTS

For a period of two (2) years from the date of purchase, if **the product** or its components are determined defective, **J Chadwick Co** will supply, at no charge to buyer, new or rebuilt parts.

## DISCLAIMER

(1) This warranty does not cover cosmetic damage or damage due to acts of God, accident, misuse, abuse, or negligence to any part of **the product**.

(2) This warranty does not cover damage due to improper operation or maintenance. Warranty is null and void if repair or modification is attempted by anyone other than **J Chadwick Co** or its authorized representatives.

Repair or replacement as provided under this warranty is the exclusive remedy of the consumer. **J Chadwick Co** shall not be liable for any incidental or consequential damages for breach of any express or implied warranty on **the product**.

To obtain warranty service, buyer must contact **J Chadwick Co** prior to return to obtain an authorization to return **the product** for service. Buyer is responsible for providing proof of sale, which may be required for warranty service. **The product** should be returned to **J Chadwick Co**, in either its original packaging or packaging affording an equal degree of protection, with a copy of the bill of sale.

Increase the versatility of the Optical Micrometer with these products. Please call for more details and pricing.



## Lab Stand Kit Model 5500

A versatile addition designed for shop and lab environments to inspect subjects requiring more clearance and easier accessibility (such as large or oddly shaped parts) than the Optical Micrometer provides when used alone.



## Surface Replication Kit Model 4400

The Surface Replication Kit features Microset® replicating compounds; the kit allows for a quick and convenient method to obtain precise measurements in hard-to reach places (such as the inside of threaded holes).

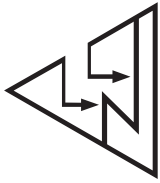

**JCHADWICK**  
Innovative Inspection Solutions



Toll Free (866) 358-9955

Tel (626) 358-9955

Fax (626) 358-1448

[www.jchadwickco.com](http://www.jchadwickco.com)

[sales@jchadwickco.com](mailto:sales@jchadwickco.com)

1005 S Mountain Ave. Monrovia CA 91016 USA