

USER'S GUIDE

Vaisala INTERCAP[®] Humidity and Temperature Transmitters HMDW80 Series

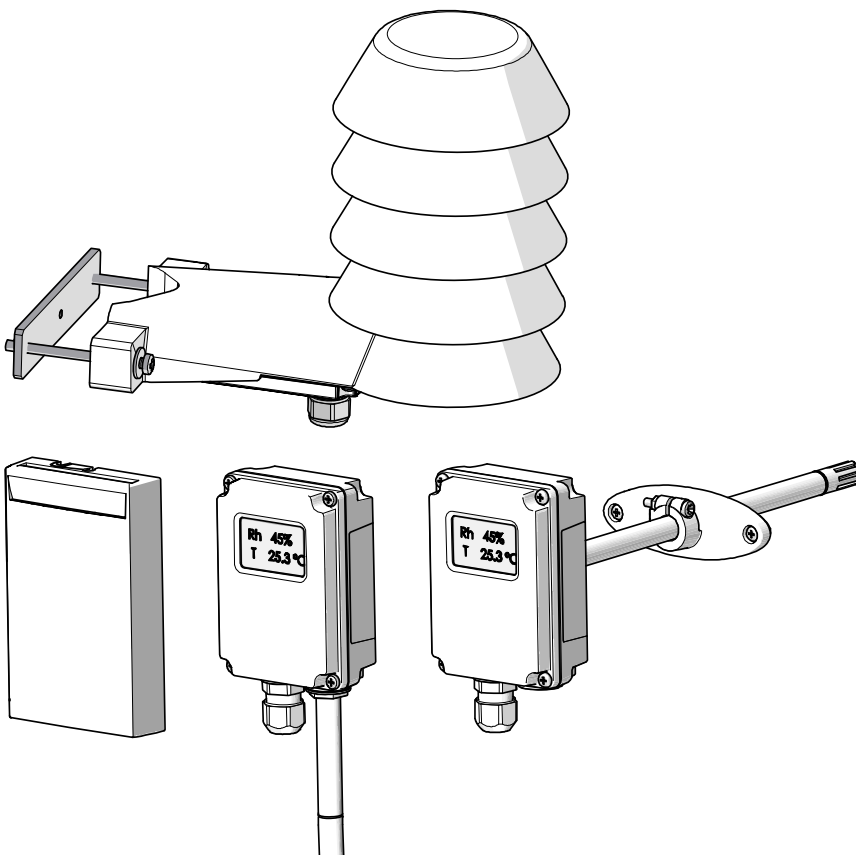

PUBLISHED BY

Vaisala Oyj
P.O. Box 26
FI-00421 Helsinki
Finland

Phone (int.): +358 9 8949 1
Fax: +358 9 8949 2227

Visit our Internet pages at www.vaisala.com.

© Vaisala 2013

No part of this manual may be reproduced, published or publicly displayed in any form or by any means, electronic or mechanical (including photocopying), nor may its contents be modified, translated, adapted, sold or disclosed to a third party without prior written permission of the copyright holder. Translated manuals and translated portions of multilingual documents are based on the original English versions. In ambiguous cases, the English versions are applicable, not the translations.

The contents of this manual are subject to change without prior notice.

This manual does not create any legally binding obligations for Vaisala towards customers or end users. All legally binding obligations and agreements are included exclusively in the applicable supply contract or the General Conditions of Sale and General Conditions of Service of Vaisala.

Table of Contents

CHAPTER 1

GENERAL INFORMATION	5
About This Manual	5
Contents of This Manual	5
Version Information	6
Related Manuals	6
Documentation Conventions	6
Safety	7
ESD Protection	7
Recycling	7
Regulatory Compliances	8
Trademarks	8
Software License	8
Warranty	8

CHAPTER 2

PRODUCT OVERVIEW	9
Introduction to HMDW80 Series	9
HMDW80 Series Transmitter Models	10
Output Parameters Explained	10
Transmitter Parts – Duct Models	11
Transmitter Parts – Wall Models	12
Transmitter Parts – Outdoor Models	14
Display	15
Analog Output Overrange Behavior	16

CHAPTER 3

INSTALLATION	17
Selecting Location	17
Installing Duct Models HMD82/83 and TMD82/83	18
Installing Wall Models HMW88 and HMW89	20
Installing Wall Models HMW82/83 and TMW82/83	21
Installing Outdoor Models HMS82/83	22
Configuration and Wiring	23
Pole installation	24
Wall installation	25
Wiring	26
HMD82(D), HMW88(D), and HMS82	26
TMD82	26
HMD83(D), HMW89(D), and HMS83	27
TMD83	27
HMW82	28
TMW82	28
HMW83	29
TMW83	29

DIP Switches	30
CHAPTER 4	
MAINTENANCE.....	33
Cleaning.....	33
Calibration	33
Replacing the INTERCAP® Humidity Sensor	34
Replacing the INTERCAP® Sensor on Models HMD82/83 and HMW88/89.....	34
Replacing the INTERCAP® Sensor on Wall Models HMW82/83.....	35
Replacing the INTERCAP® Sensor on Outdoor Models HMS82/83.....	36
CHAPTER 5	
TROUBLESHOOTING.....	41
Problem Situations	41
Analog Output Error State	42
Error Messages on the Display	42
Technical Support	43
Product Returns.....	43
CHAPTER 6	
TECHNICAL DATA	45
Specifications	45
Spare Parts and Accessories	48

List of Figures

Figure 1	Parts of Duct Mounted Models (HMD82/83 and TMD82/83) ...	11
Figure 2	Parts of Wall Mounted Models (HMW88/89).....	12
Figure 3	Parts of Wall Mounted Models (HMW82/83 and TMW82/83) ..	13
Figure 4	Parts of Outdoor Models (HMS82/83).....	14
Figure 5	Startup Screens (HMD83D)	15
Figure 6	Measurement Screen (HMD83D).....	15
Figure 7	Measurement Screen with Error (HMD83D)	15
Figure 8	Duct Model Installation	19
Figure 9	Position the Sensor to Center of Duct.....	19
Figure 10	Duct Model Dimensions (HMD82/83 and TMD82/83).....	19
Figure 11	Wall Model Dimensions (HMW88/89)	20
Figure 12	Wall Model Dimensions (HMW82/83 and TMW82/83)	21
Figure 13	Outdoor Model Dimensions (HMS82/83)	22
Figure 14	Location of DIP Switches and Screw Terminal	23
Figure 15	HMS82/83 Pole Installation.....	24
Figure 16	Securing the Cable on a Pole	24
Figure 17	HMS82/83 Wall Installation	25
Figure 18	Securing the Cable on a Wall.....	25
Figure 19	DIP Switches on Component Board.....	30
Figure 20	Sensors on HMD82/83 and HMW88/89 Models	34
Figure 21	INTERCAP [®] Sensor on HMW82/83 Models	35
Figure 22	Unplugging the Screw Terminal	36
Figure 23	Opening the Radiation Shield Screws.....	37
Figure 24	Removing the Radiation Shield Screws	37
Figure 25	Location of Locking Tab	38
Figure 26	Removing the Radiation Shield	38
Figure 27	Filter Removed	39
Figure 28	Sensors on HMS82/83 Models	39

List of Tables

Table 1	Manual Revisions	6
Table 2	Related Manuals	6
Table 3	HMDW80 Series Transmitter Models.....	10
Table 4	Parameters Supported by HMDW80 Series	10
Table 5	DIP Switch Positions for Metric Output	31
Table 6	DIP Switch Positions for Non-Metric Output	31
Table 7	Possible Problem Situations and Their Remedies	41
Table 8	Error Messages on the Display	42
Table 9	Specifications for HMW82/83 and TMW82/83	45
Table 10	Specifications for HMD82/83, TMD82/83, HMW88/89, and HMS82/83	46
Table 11	Specifications for HMD82/83D and HMW88/89D	47
Table 12	Operating Environment (All Models)	47
Table 13	Inputs and Outputs	47
Table 14	Mechanics	48
Table 15	HMDW80 Series Spare Parts and Accessories	48

This page intentionally left blank.

CHAPTER 1

GENERAL INFORMATION

This chapter provides general notes for the manual and the HMDW80 series.

About This Manual

This manual provides information for installing, operating, and maintaining HMDW80 series transmitters.

Contents of This Manual

This manual consists of the following chapters:

- Chapter 1, General Information, provides general notes for the manual and the HMDW80 series.
- Chapter 2, Product Overview, introduces the features and options of the HMDW80 series transmitters.
- Chapter 3, Installation, provides you with information that is intended to help you install HMDW80 series transmitters.
- Chapter 4, Maintenance, provides information that is needed in basic maintenance of HMDW80 series.
- Chapter 5, Troubleshooting, describes possible problems, their probable causes and remedies, and provides contact information for technical support.
- Chapter 6, Technical Data, provides the technical data of the HMDW80 series.

Version Information

Table 1 Manual Revisions

Manual Code	Description
M211510EN-C	<p>June 2013. This manual. Changes:</p> <ul style="list-style-type: none"> - Added outdoor transmitter models HMS82 and HMS83. - Changed PTFE membrane filter model from 230727SP (30 mm long) to ASM210856SP (24.5 mm long). - Changed PTFE filter model from 219452SP (40 mm long) to DRW239993SP (22 mm long). - Improved IP classification of models with display to IP65.
M211510EN-B	<p>March 2013. Previous version. Updated list of spare parts and accessories.</p>

Related Manuals

Table 2 Related Manuals

Manual Code	Manual Name
M211507EN	HMD82 HMD83 Wiring Diagram
M211508EN	HMW88 HMW89 Wiring Diagram
M211328EN	HMW82 HMW83 Quick Guide
M211509EN	HMS82 HMS83 Quick Guide

Documentation Conventions

Throughout the manual, important safety considerations are highlighted as follows:

WARNING

Warning alerts you to a serious hazard. If you do not read and follow instructions very carefully at this point, there is a risk of injury or even death.

CAUTION

Caution warns you of a potential hazard. If you do not read and follow instructions carefully at this point, the product could be damaged or important data could be lost.

NOTE

Note highlights important information on using the product.

Safety

The HMDW80 series transmitter delivered to you has been tested for safety and approved as shipped from the factory. Note the following precautions:

WARNING

Installation of HMDW80 series transmitters may involve working at a height. Assess the risks and plan your work so it is carried out safely. Try avoiding work at height, if you can.

CAUTION

Make sure the wires are de-energized when you connect them to the screw terminals.

CAUTION

Do not modify the unit. Improper modification can damage the product or lead to malfunction.

ESD Protection

Electrostatic Discharge (ESD) can cause immediate or latent damage to electronic circuits. Vaisala products are adequately protected against ESD for their intended use. It is possible to damage the product, however, by delivering electrostatic discharges when touching, removing, or inserting any objects inside the equipment housing.

To make sure you are not delivering high static voltages yourself, always hold component boards by the edges and avoid touching the component contacts.

Recycling



Recycle all applicable material.



Dispose of the unit according to statutory regulations. Do not dispose of with regular household refuse.

Regulatory Compliances

HMDW80 series complies with the following performance and environmental test standards:

- EMC-Directive

Conformity is shown by compliance with the following standards:

- EN 61326-1: Electrical equipment for measurement, control, and laboratory use – EMC requirements – For use in industrial locations.
- EN 55022: Information technology equipment – Radio disturbance characteristics – Limits and methods of measurement.



Trademarks

INTERCAP[®] is a registered trademark of Vaisala Oyj.

Software License

This product contains software developed by Vaisala. Use of the software is governed by license terms and conditions included in the applicable supply contract or, in the absence of separate license terms and conditions, by the General License Conditions of Vaisala Group.

Warranty

Visit our Internet pages for standard warranty terms and conditions:
www.vaisala.com/warranty.

Please observe that any such warranty may not be valid in case of damage due to normal wear and tear, exceptional operating conditions, negligent handling or installation, or unauthorized modifications. Please see the applicable supply contract or Conditions of Sale for details of the warranty for each product.

CHAPTER 2

PRODUCT OVERVIEW

This chapter introduces the features and options of the HMDW80 series transmitters.

Introduction to HMDW80 Series

Vaisala INTERCAP[®] Humidity and Temperature Transmitter Series HMDW80 measure relative humidity and temperature in various building automation applications. Transmitters combine easy installation and reliable operation with a low requirement for maintenance.

HMDW80 series includes transmitters for wall and duct mounting, humid areas, and for outdoor installation. It also includes temperature-only transmitters and transmitters with an optional display. Calculated humidity parameters – dewpoint, wet bulb temperature, and enthalpy – are also available.

HMDW80 series transmitters require minimal maintenance thanks to their excellent sensor stability and high-quality materials. If necessary, the INTERCAP[®] humidity sensor can be easily exchanged in the field with practically no downtime.

Features provided by transmitters in the HMDW80 series:

- ± 3.0 %RH accuracy.
- 0 ... 100 %RH measurement range.
- User exchangeable INTERCAP[®] humidity sensor for easy field replacement.
- Several output parameters; see section HMDW80 Series Transmitter Models on page 10 for list of supported parameters by transmitter model.
- Several IP65-classified models for demanding HVAC applications.
- UL-V0 flammability rating.

HMDW80 Series Transmitter Models

Table 3 below lists the most important differences between the HMDW80 series transmitter models. For technical specifications, see Chapter 6, Technical Data, on page 45.

Table 3 HMDW80 Series Transmitter Models

Model	Type	Outputs	Display	IP Rating	Output Parameters
HMD82	Duct	2 × 4 ... 20 mA	No	IP65	T, RH, Td, h, Tw
HMD82D	Duct	2 × 4 ... 20 mA	Yes	IP65	T, RH, Td, h, Tw
TMD82	Duct	1 × 4 ... 20 mA	No	IP65	T
HMD83	Duct	2 × 0 ... 10 V	No	IP65	T, RH, Td, h, Tw
HMD83D	Duct	2 × 0 ... 10 V	Yes	IP65	T, RH, Td, h, Tw
TMD83	Duct	1 × 0 ... 10 V	No	IP65	T
HMW82	Wall	2 × 4 ... 20 mA	No	IP30	T, RH
TMW82	Wall	1 × 4 ... 20 mA	No	IP30	T
HMW83	Wall	2 × 0 ... 10 V	No	IP30	T, RH
TMW83	Wall	1 × 0 ... 10 V	No	IP30	T
HMW88	Wall	2 × 4 ... 20 mA	No	IP65	T, RH, Td, h, Tw
HMW88D	Wall	2 × 4 ... 20 mA	Yes	IP65	T, RH, Td, h, Tw
HMW89	Wall	2 × 0 ... 10 V	No	IP65	T, RH, Td, h, Tw
HMW89D	Wall	2 × 0 ... 10 V	Yes	IP65	T, RH, Td, h, Tw
HMS82	Outdoor	2 × 4 ... 20 mA	No	IP65	T, RH, Td, h, Tw
HMS83	Outdoor	2 × 0 ... 10 V	No	IP65	T, RH, Td, h, Tw

Output Parameters Explained

Table 4 Parameters Supported by HMDW80 Series

Parameter	Symbol	Unit(s)	Description
Temperature	T	°C °F	Temperature in Celsius or Fahrenheit scale.
Relative humidity	RH	%	Ratio of the partial pressure of water vapor in the air to the saturation vapor pressure of air at the current temperature.
Dewpoint	Td	°C °F	Temperature at which the water vapor in the air will condense into water at the current pressure. When the dewpoint is below 0 °C, the transmitter outputs frostpoint (Tf) instead of dewpoint.
Enthalpy	h	kJ/kg BTU/lb	Sum of the internal energy of a thermodynamic system.
Wet bulb temperature	Tw	°C °F	The minimum temperature that can be reached by evaporative cooling in the current conditions.

Transmitter Parts – Duct Models

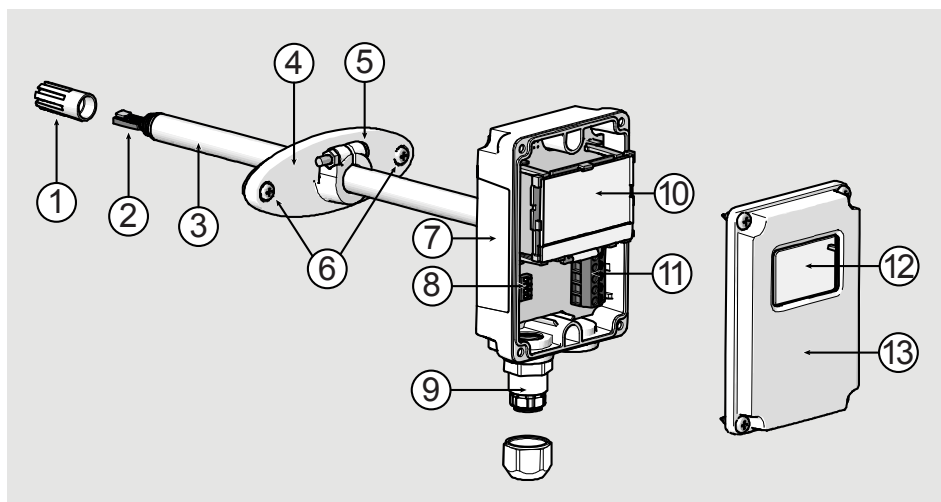

1302-018

Figure 1 Parts of Duct Mounted Models (HMD82/83 and TMD82/83)

- 1 = PTFE membrane filter.
- 2 = INTERCAP[®] humidity sensor and temperature sensor.
Not included in TMD82 and TMD83 models.
- 3 = Probe.
- 4 = Fastening flange.
- 5 = Tightening screw for fastening flange.
- 6 = Screws for attaching the flange to a duct (2 pcs included).
- 7 = Type label.
- 8 = DIP switches for selecting humidity parameter and display units.
Not included in TMD82 and TMD83 models.
- 9 = Cable gland. Suitable for 4 ... 8 mm diameter cable.
- 10 = Display (in HMD82D and HMD83D models).
- 11 = Screw terminals.
- 12 = Window for display (in HMD82D and HMD83D models).
- 13 = Transmitter cover with captive screws.

Transmitter Parts – Wall Models

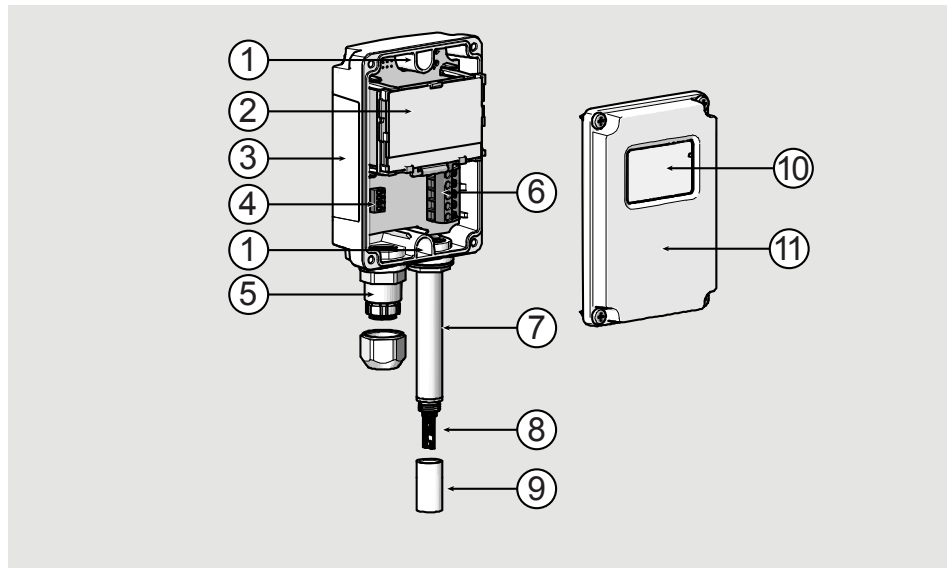

1302-019

Figure 2 Parts of Wall Mounted Models (HMW88/89)

- 1 = Screw holes for mounting (2 pcs).
- 2 = Display (in HMW88D and HMW89D models).
- 3 = Type label.
- 4 = DIP switches for selecting humidity parameter and display units
- 5 = Cable gland. Suitable for 4 ... 8 mm diameter cable.
- 6 = Screw terminals.
- 7 = Probe.
- 8 = INTERCAP[®] humidity sensor and temperature sensor.
- 9 = PTFE filter.
- 10 = Window for display (in HMW88D and HMW89D models)
- 11 = Transmitter cover with captive screws.

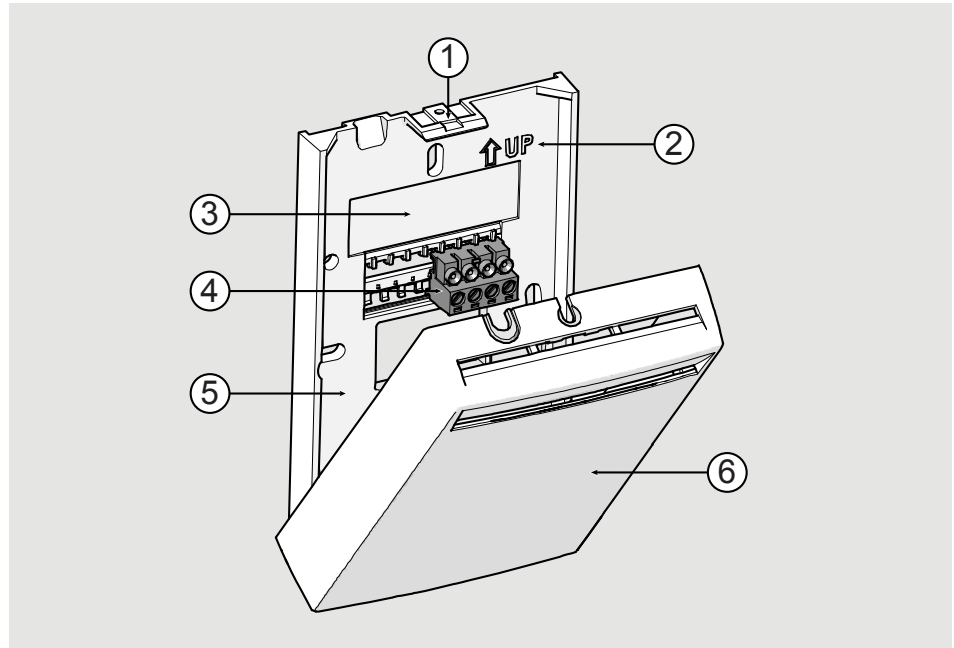

1302-020

Figure 3 **Parts of Wall Mounted Models (HMW82/83 and TMW82/83)**

- 1 = Opening tab: push down to open the transmitter.
- 2 = Direction arrow. Must point up after mounting base has been installed on the wall.
- 3 = Wiring label.
- 4 = Screw terminals.
- 5 = Mounting base.
- 6 = Transmitter cover with component board.

Transmitter Parts – Outdoor Models

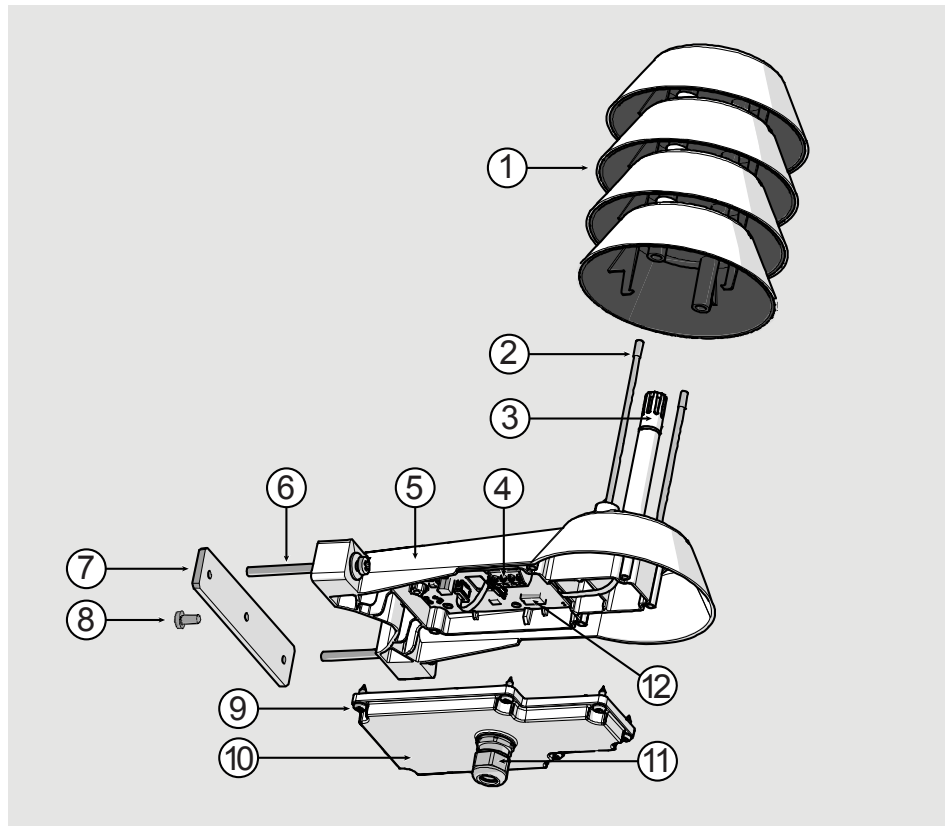

1304-048

Figure 4 **Parts of Outdoor Models (HMS82/83)**

- 1 = Radiation shield. Do not remove for installation, only when changing sensor or filter.
- 2 = Long screws that keep the radiation shield in place (2 pcs), 3 mm hex socket.
- 3 = INTERCAP® humidity sensor and temperature sensor under PTFE membrane filter.
- 4 = Screw terminal. Detachable for easy installation.
- 5 = Transmitter body.
- 6 = Screws for pole mounting (2 pcs), medium size crosshead type (Pozidriv).
- 7 = Clamp for pole mounting. The holes are threaded for the included pole mounting screws and set screw.
- 8 = Set screw, medium size crosshead type (Pozidriv). Install after pole mounting to stop the transmitter from turning.
- 9 = Medium size crosshead screws (6 pcs) that hold the transmitter cover in place.
- 10 = Transmitter cover.
- 11 = Cable gland. Suitable for 4 ... 8 mm diameter cable.
- 12 = Configuration DIP switches. See section DIP Switches on page 30.

Display

Display is present on the following models:

- HMD82D and HMD83D
- HMW88D and HMW89D

When the transmitter is powered on, it displays a sequence of information screens about the transmitter and its analog outputs. The screens are shown for a few seconds each. Checking the screens on startup is a good way to verify that the transmitter's configuration DIP switches are set correctly.

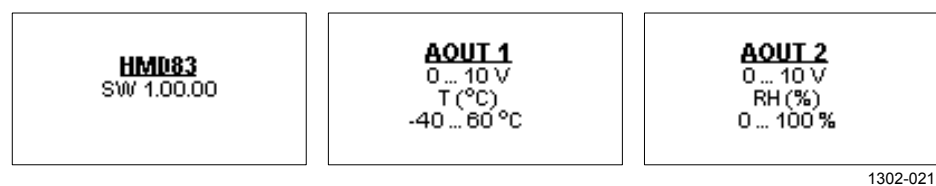

1302-021

Figure 5 Startup Screens (HMD83D)

After the startup screens have been displayed, the transmitter will show the measurement screen.

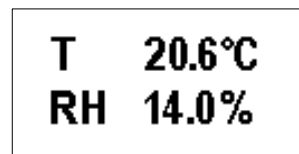

1302-024

Figure 6 Measurement Screen (HMD83D)

If one of the transmitter's error states is active, a notification symbol and error text will appear on the screen. Depending on the error, the affected measurement readings may be replaced by asterisks "*". For more information on the possible errors, see section Error Messages on the Display on page 42.

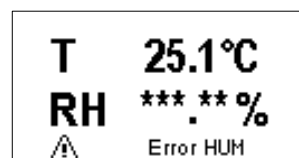

1302-025

Figure 7 Measurement Screen with Error (HMD83D)

Analog Output Overrange Behavior

Analog outputs of the HMDW80 series transmitters have a defined behavior when the values measured by the transmitter are outside the scaled analog output range:

- Output is clipped at the end of the range.
- Output is set to error state when measured value is 5% outside the scaled range. See section Analog Output Error State on page 42.
- Output resumes normal function when measured value is back on the scaled range.

NOTE

HMW82/83 and TMW82/83 transmitters are different from the rest of the HMDW80 series. Their analog output is clipped at 10% outside the scaled range, and their analog outputs enter the error state when the measured value is 20% outside the range.

For example, consider the temperature output of the HMD82 transmitter. The output is 4 ... 20 mA, scaled to -40 ... +60 °C (-40 ... +140 °F).

- When measured temperature rises above +60 °C (+140 °F), the output rises to 20 mA and stops rising even if temperature rises further.
- If the temperature rises above +65 °C (+149 °F), the output enters the error state of 3.6 mA.

NOTE

This overrange behavior does not mean there is a problem with the measurements, and it does not affect the readings shown on the display (if included in the transmitter model). The display always shows the currently measured readings if the measurement is operating without error. For more information on transmitter errors, see section Error Messages on the Display on page 42.

CHAPTER 3

INSTALLATION

This chapter provides you with information that is intended to help you install HMDW80 series transmitters.

Selecting Location

When mounting duct model transmitters:

- Avoid installing in a location where condensation may fall on the sensor inside the duct.
- Position the sensor in the center of the duct.
- Select a site where the transmitter can be installed horizontally, onto the side of the duct.

When mounting wall model transmitters:

- Select a location that represents well the area of interest.
- Do not install on the ceiling.
- Avoid placing the transmitter near heat and moisture sources, close to the discharge of the supply air ducts, and in direct sunlight.

When mounting outdoor transmitters:

- Install in a place that receives minimal direct sunlight. In the northern hemisphere, the North side of the building typically provides a suitable shaded location.
- Avoid placing the transmitter near windows, air conditioning units, or other heat and moisture sources such as cooling towers.
- Install the transmitter at least 2.5 m above ground level.

Installing Duct Models HMD82/83 and TMD82/83

REQUIRED TOOLS

- Medium size crosshead screwdriver (Pozidriv) for screws on cover and flange.
- Small slotted screwdriver for screw terminals.
- Drill with 2.5 mm and 13 mm bits for making the installation holes.
- Tools for cutting and stripping wires.
- 19 mm open-end wrench for tightening the cable gland.

1. Remove the yellow transport protection cap and separate the fastening flange from the transmitter.
2. Use the flange to mark the location and size of the installation holes on the side of the duct.
3. Drill the installation holes in the duct. Refer to Figure 8 below.
4. Secure the fastening flange to the duct with the two screws (included).
5. Push the probe of the transmitter through the flange and into the duct. The probe should reach far enough so that the sensor is located in the middle of the duct.
6. Secure the transmitter to the flange by tightening the screw on the flange that holds the probe in place.
7. Open the transmitter cover, and route the power and signal cable through the cable gland. Connect the wires to the screw terminals. Refer to section Wiring on page 26.
8. Check that the DIP switches (if present in your transmitter model) are set as desired. See section DIP Switches on page 30.
9. Tighten the cable gland and close the transmitter cover.

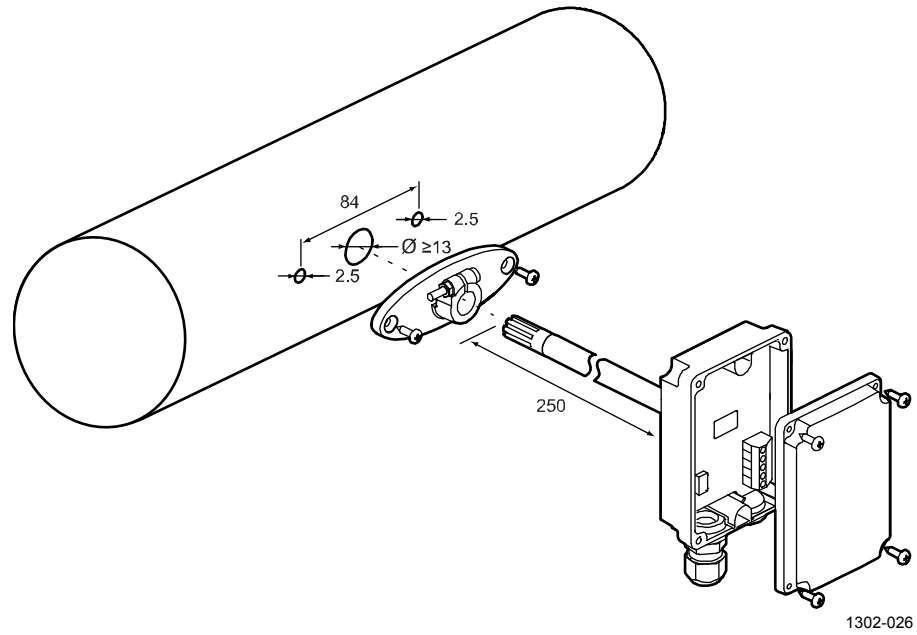

Figure 8 Duct Model Installation

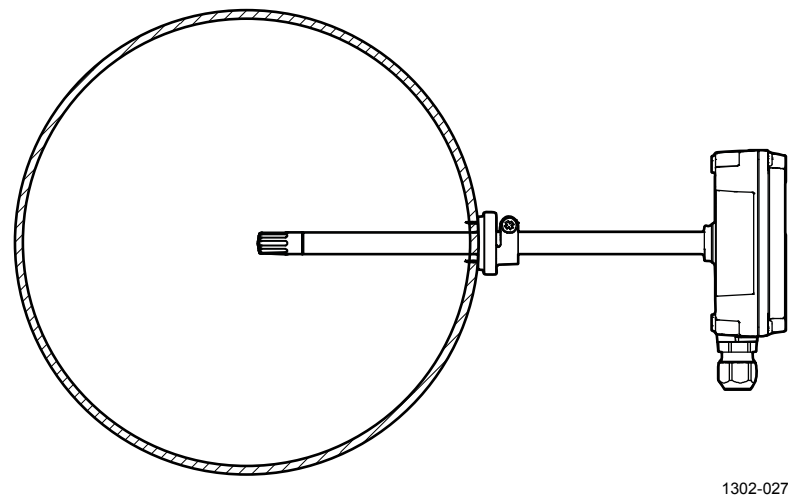

Figure 9 Position the Sensor to Center of Duct

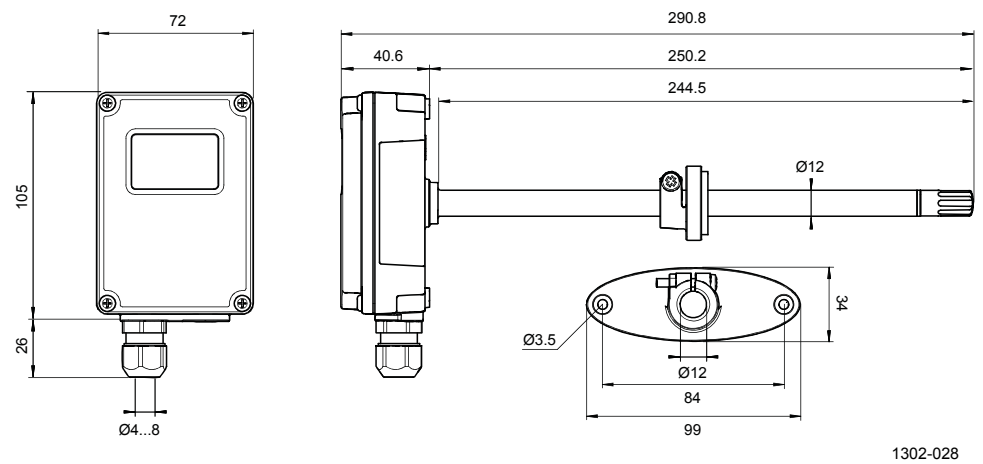

Figure 10 Duct Model Dimensions (HMD82/83 and TMD82/83)

Installing Wall Models HMW88 and HMW89

REQUIRED TOOLS

- Medium size crosshead screwdriver (Pozidriv) for cover screws.
- Small slotted screwdriver for screw terminals.
- Two installation screws: $\text{Ø} < 3.5$ mm, head $\text{Ø} < 10$ mm.
- Depending on the wall material and screw type, you may need a drill and a suitable drill bit to make installation holes for screws.
- Tools for cutting and stripping wires.
- 19 mm open-end wrench for tightening the cable gland.

1. Open the transmitter cover and use two screws (not included) to attach the transmitter to the wall. The probe and cable gland should point down.
2. Route the power and signal cable to the screw terminals and connect the wires. Refer to section Wiring on page 26.
3. Close the transmitter cover and remove the yellow transport protection cap from the probe.

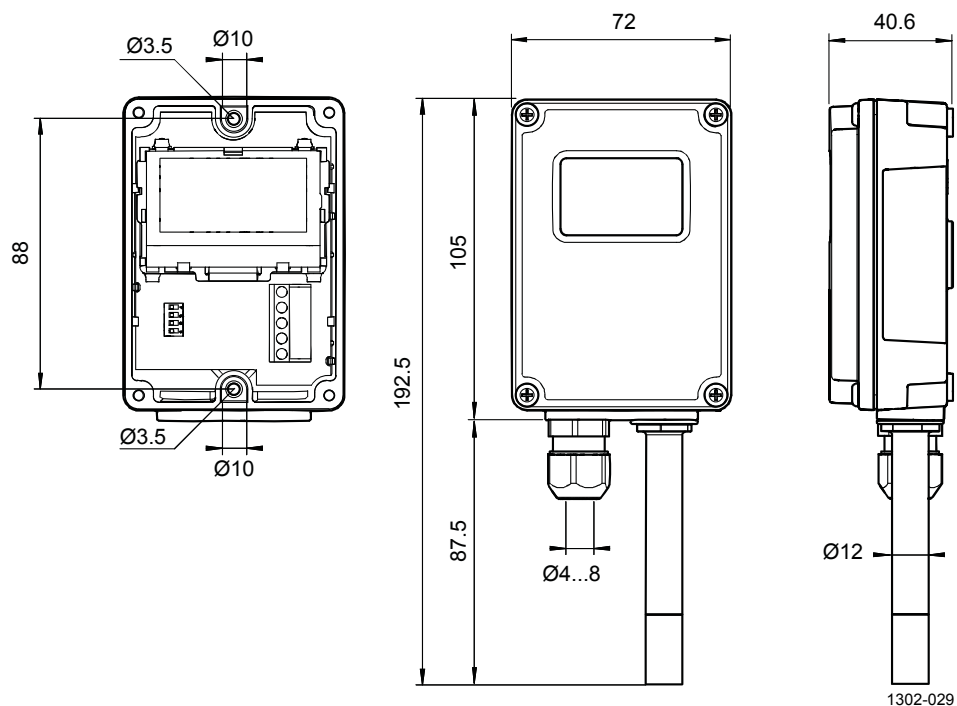

Figure 11 Wall Model Dimensions (HMW88/89)

Installing Wall Models HMW82/83 and TMW82/83

REQUIRED TOOLS

- Small flat head screwdriver for opening the transmitter and for screw terminals.
- Two screws, max \varnothing 4 mm.
- Depending on the wall material and screw type, you may need a drill and a suitable drill bit to make installation holes for screws.
- Tools for cutting and stripping wires.

1. Use a flat head screwdriver to push down the tab on top of the transmitter and separate the mounting base from the transmitter cover.
2. Use the mounting holes to attach the mounting base securely. Use at least two screws (not included, max \varnothing 4 mm).

NOTE

The arrow on the mounting base must point straight up after installation. Proper orientation is important: air must flow through the vents on the bottom and top.

3. Route the power and signal cable to the screw terminals and connect the wires. Refer to section Wiring on page 26.
4. Close the transmitter cover when done.

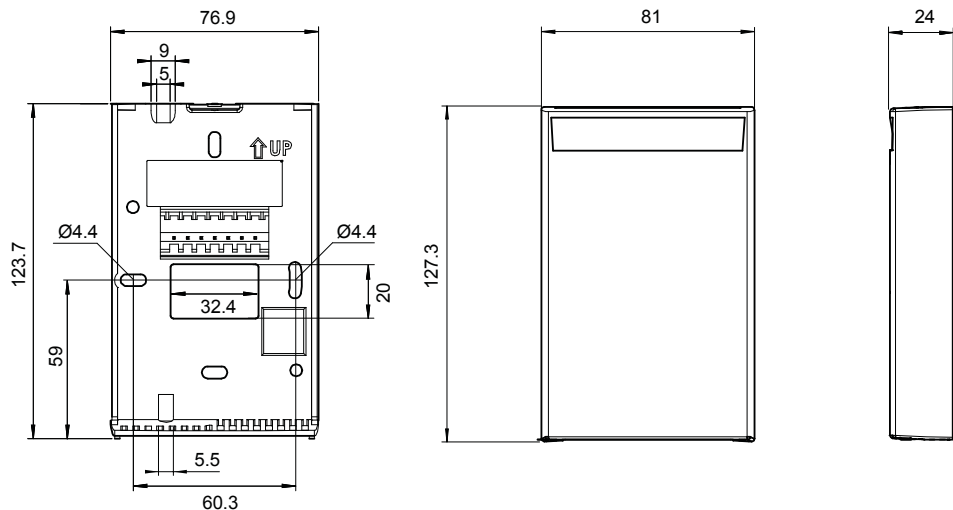

1302-030

Figure 12 Wall Model Dimensions (HMW82/83 and TMW82/83)

Installing Outdoor Models HMS82/83

WARNING

Assess the risks posed by the height and accessibility of the installation location, and plan your work so it is carried out safely. Try avoiding work at height, if you can.

REQUIRED TOOLS

- Medium size crosshead screwdriver (Pozidriv)
- Small slotted screwdriver for screw terminals.
- Tools for cutting and stripping wires.
- 19 mm open-end wrench for tightening the cable gland.

Additional tools for pole installation:

- Zip ties for securing the cable to the pole.

Additional tools for wall installation:

- Drill and bits.
- Screws (2 pcs, $\text{Ø} < 5.5 \text{ mm}$) and wall plugs
- Cable clips for securing the cable to the wall.

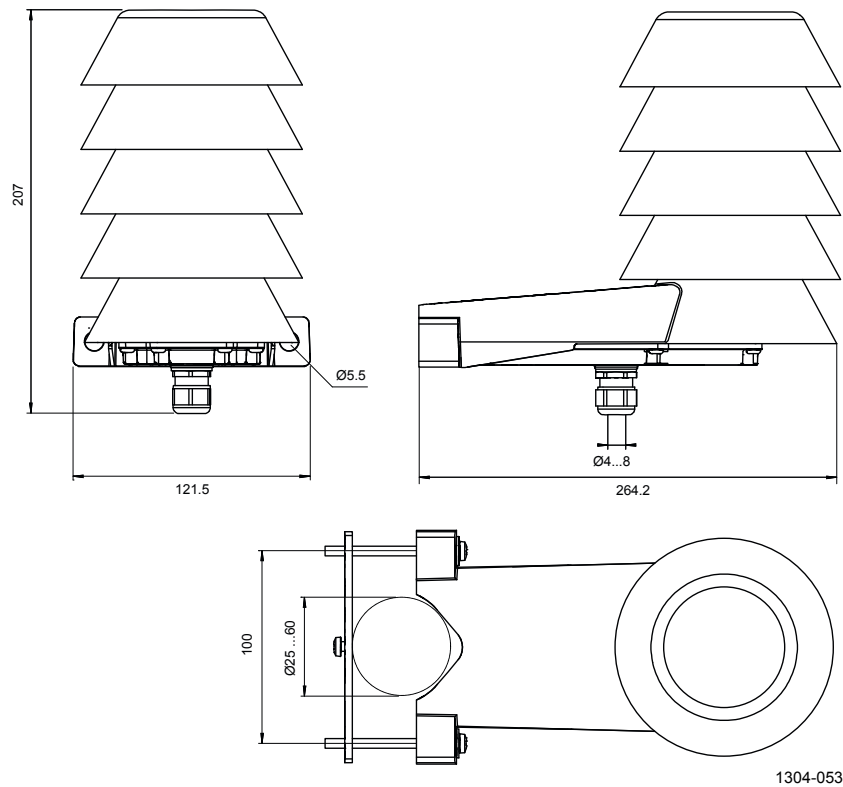
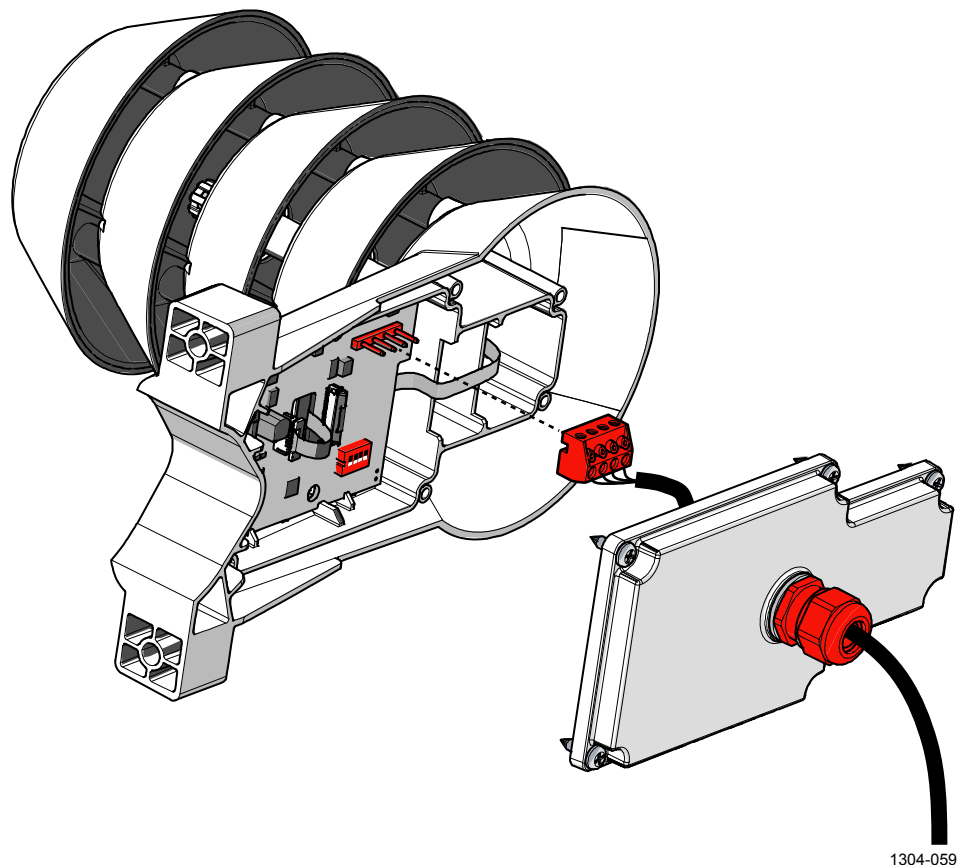

Figure 13 Outdoor Model Dimensions (HMS82/83)

Configuration and Wiring

To minimize working at height at the installation location, prepare the transmitter configuration and wiring before climbing up.

1. Open the six screws that hold the transmitter cover.
2. Check that the DIP switches are set as desired. See section DIP Switches on page 30.
3. Route the power and signal cable to the screw terminals and connect the wires. Refer to section Wiring on page 26.
4. Disconnect the screw terminal block by pulling it away from the component board.
5. Adjust the length of cable between the cable gland and the terminal block. Make the cable short enough to close the cover without leaving a cable loop in the transmitter.
6. Tighten the cable gland. Leave the cover off for now.



1304-059

Figure 14 Location of DIP Switches and Screw Terminal

Pole installation

NOTE

Recommended pole diameter for HMS82/83 installation with the supplied clamp and screws is 25 ... 60 mm.

1. Use the supplied clamp and screws to mount the transmitter on a pole.
2. To prevent the transmitter from turning on the pole, tighten the set screw on the center hole of the clamp.

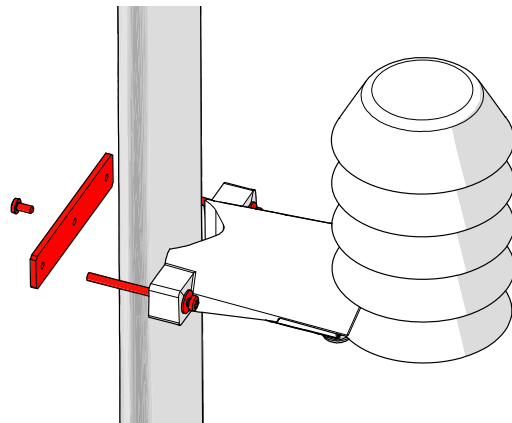

1304-054

Figure 15 HMS82/83 Pole Installation

3. Plug in the screw terminal block, close the cover, and tighten the screws.
4. Secure the cable to the pole using a zip tie. Allow some cable to hang down from the cable gland to prevent water from entering the transmitter along the cable.

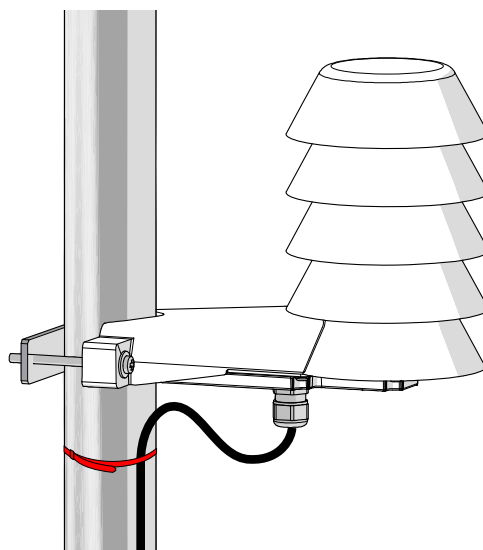

1304-056

Figure 16 Securing the Cable on a Pole

Wall installation

1. Drill two holes for wall plugs 100 mm apart.
2. Place the wall plugs in the holes.
3. Mount the transmitter using two screws of sufficient length.

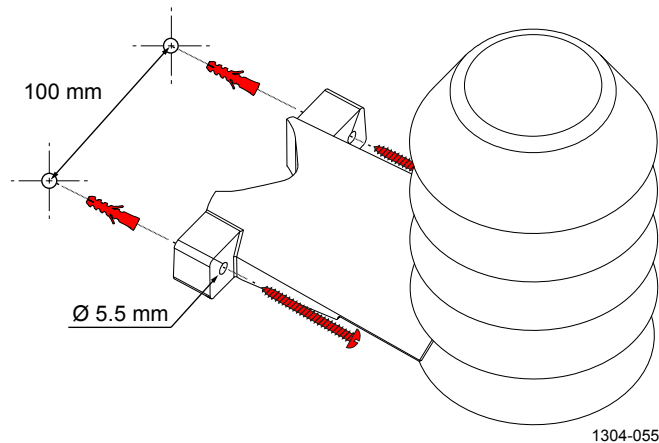

Figure 17 HMS82/83 Wall Installation

4. Plug in the screw terminal block, close the cover, and tighten the screws.
5. Secure the cable to the wall using cable ties. Allow some cable to hang down from the cable gland to prevent water from running to the transmitter along the cable.

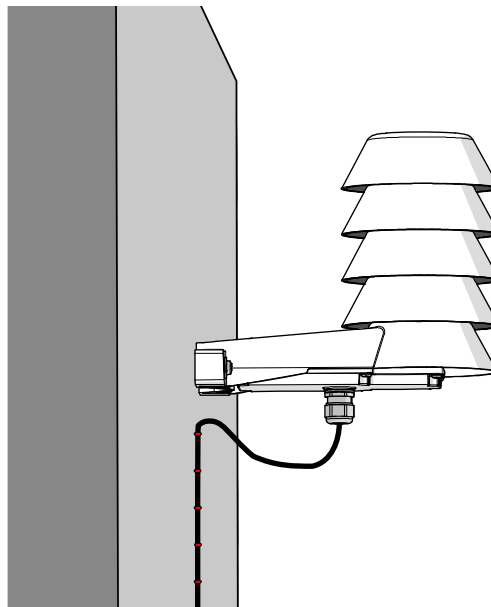

Figure 18 Securing the Cable on a Wall

Wiring

WARNING Connect only de-energized wires.

NOTE Transmitters with a configurable humidity output parameter use the marking **HUM** on the screw terminal labels. The default output parameter is relative humidity (RH) with output scaled to 0 ... 100 %RH, but the parameter can be changed using DIP switches. Changing the parameter also changes the output scaling. See section DIP Switches on page 30.

HMD82(D), HMW88(D), and HMS82

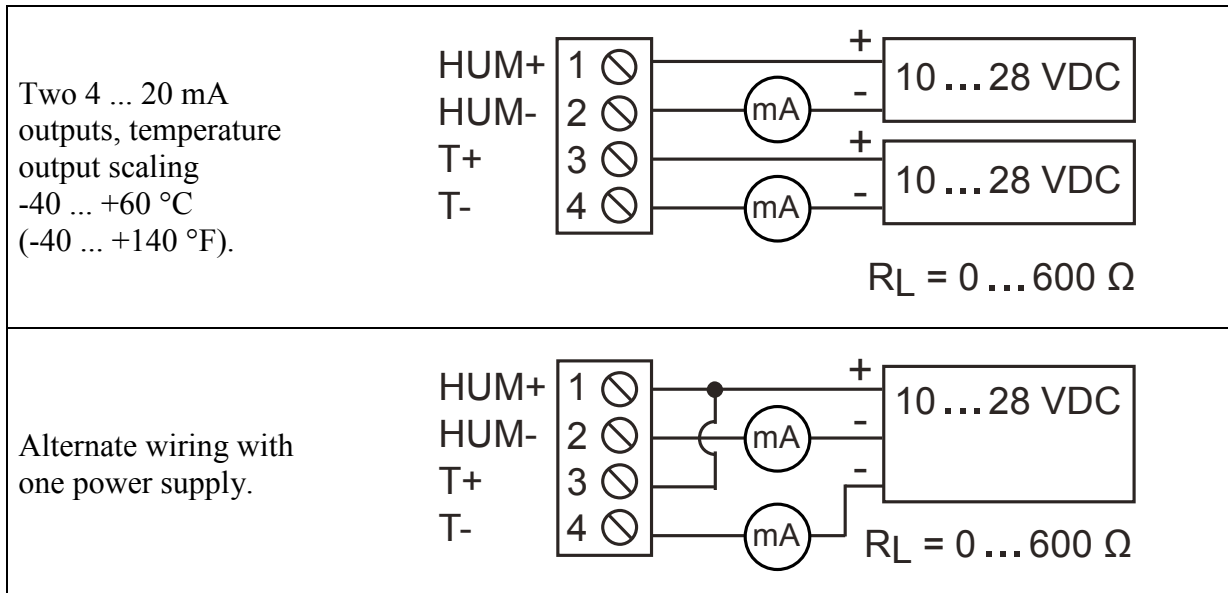

TMD82

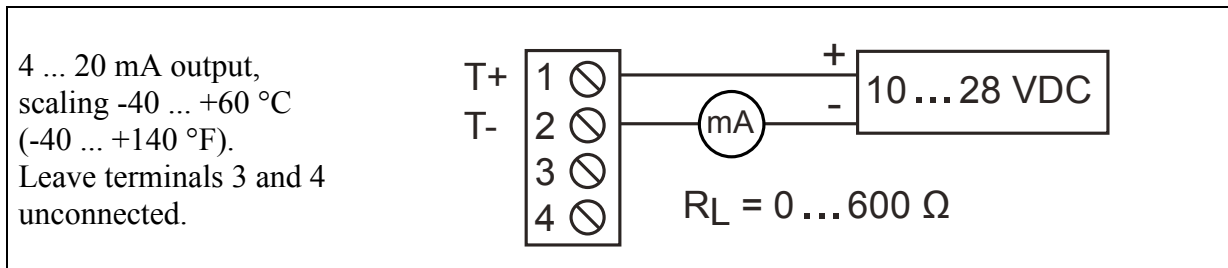

HMD83(D), HMW89(D), and HMS83

Two 0 ... 10 V outputs,
temperature output
scaling -40 ... +60 °C
(-40 ... +140 °F).

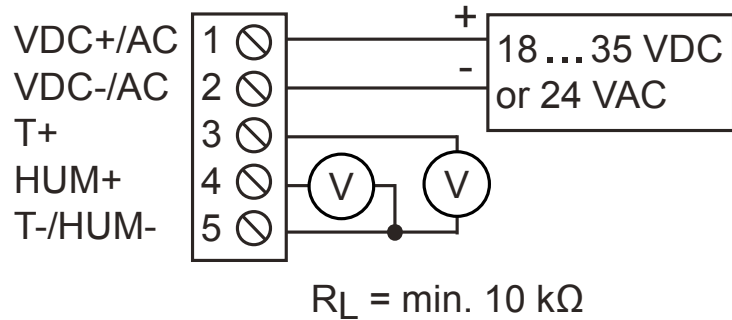

Terminals 2 and 5 are
internally connected on
the transmitter, so you
can also use a cable with
four wires.

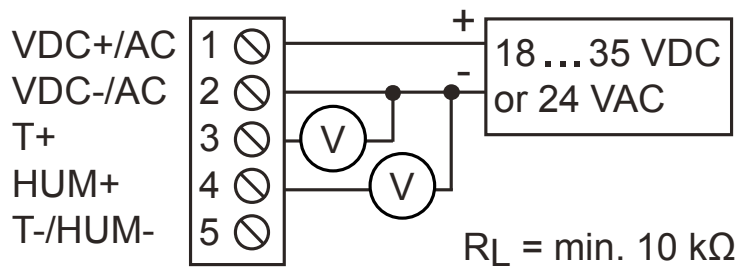

TMD83

One 0 ... 10 V output,
scaling -40 ... +60 °C
(-40 ... +140 °F).

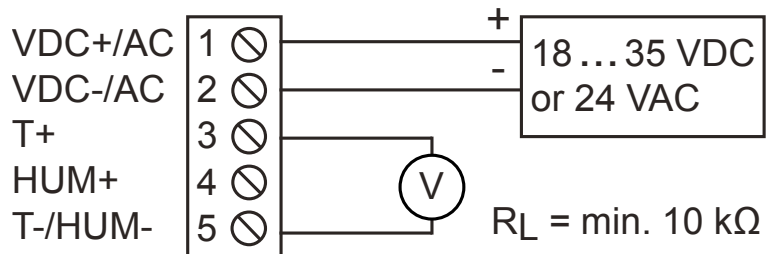

Terminals 2 and 5 are
internally connected on
the transmitter, so you
can also use a cable with
three wires.

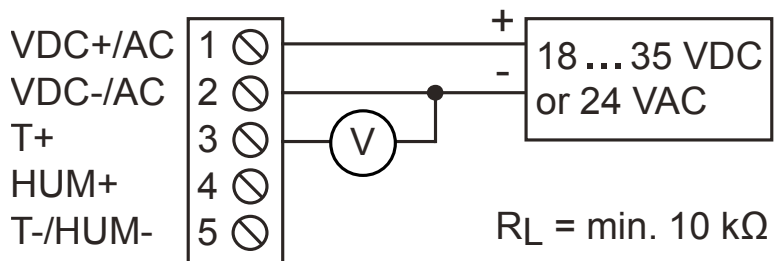

HMW82

Two 4 ... 20 mA outputs, temperature output scaling -5 ... +55 °C (+23 ... +131 °F).

You must connect the RH channel of the HMW82, even if you only want to measure temperature. Connecting the T channel is optional.

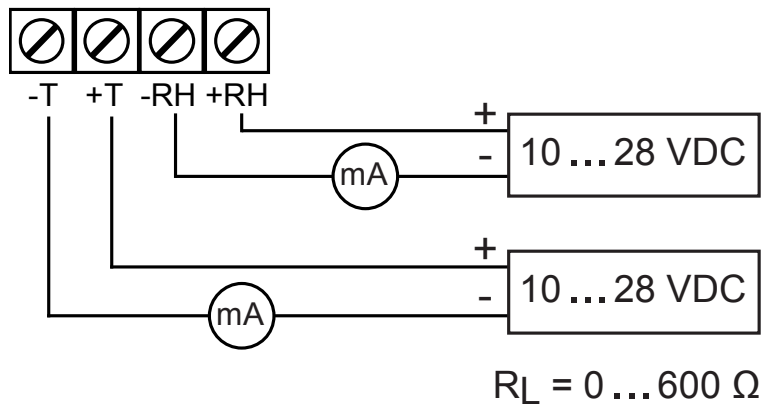

TMW82

One 4 ... 20 mA output, scaling -5 ... +55 °C (+23 ... +131 °F).

Leave the two terminals on the left unconnected.

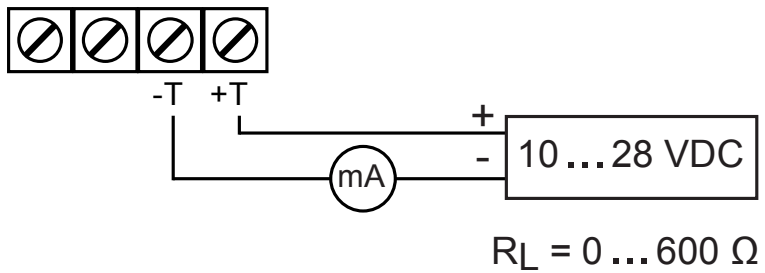

HMW83

Two 0 ... 10 V outputs,
temperature output
scaling -5 ... +55 °C
(+23 ... +131 °F).

This is the
recommended wiring
for long cables.

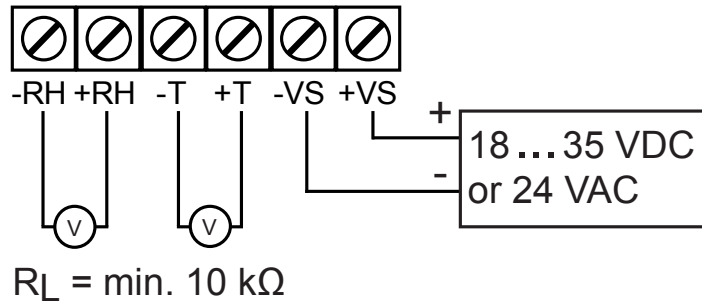

3-wire connection with -
VS as common ground.
Not recommended if
cable resistance is more
than 2.5 Ω.

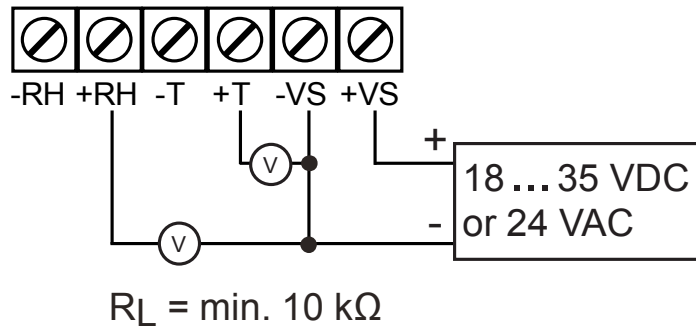

TMW83

One 0 ... 10 V output,
scaling -5 ... +55 °C
(+23 ... +131 °F).

This is the
recommended wiring
for long cables.

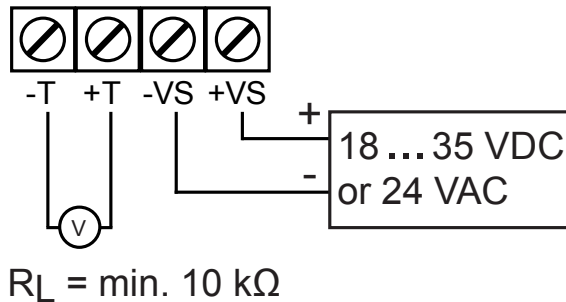

3-wire connection with
-VS as common ground.
Not recommended if
cable resistance is more
than 2.5 Ω.

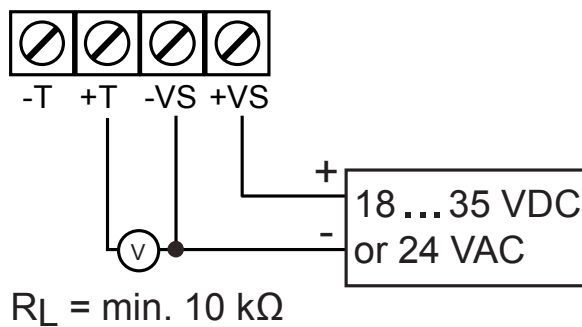

DIP Switches

The DIP switches on the component board control the humidity output parameter and scaling, and the units that are shown on the display. The switches are present on the following models:

- HMD82(D) and HMD83(D)
- HMW88(D) and HMW89(D)
- HMS82 and HMS83

Figure 19 below shows the default position of the DIP switches. The default settings are:

- Metric units shown on display.
- Relative humidity (RH) selected as humidity output parameter.

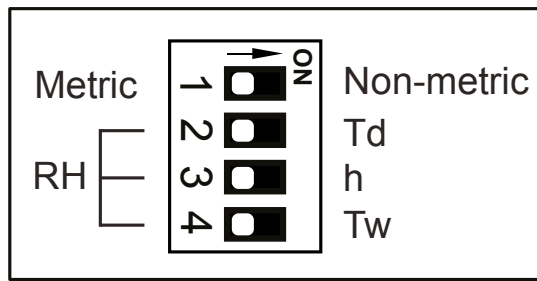

1302-053

Figure 19 **DIP Switches on Component Board**

Table 5 DIP Switch Positions for Metric Output

DIP Position	Analog Output Parameter and Scaling	Parameters and Units on Display
	Relative humidity (RH) 0 ... 100 % Temperature (T) -40 ... +60 °C	RH (%) T (°C)
	Dewpoint (Td) -40 ... +60 °C Temperature (T) -40 ... +60 °C	Td (°C) T (°C)
	Enthalpy (h) -40 ... +460 kJ/kg Temperature (T) -40 ... +60 °C	h (kJ/kg) T (°C)
	Wet bulb temperature (Tw) -40 ... +60 °C Temperature (T) -40 ... +60 °C	Tw (°C) T (°C)

Table 6 DIP Switch Positions for Non-Metric Output

DIP Position	Analog Output Parameter and Scaling	Parameters and Units on Display
	Relative humidity (RH) 0 ... 100 % Temperature (T) -40 ... +140 °F	RH (%) T (°F)
	Dewpoint (Td) -40 ... +140 °F Temperature (T) -40 ... +140 °F	Td (°F) T (°F)
	Enthalpy (h) -10 ... +190 BTU/lb Temperature (T) -40 ... +140 °F	h (BTU/lb) T (°F)
	Wet bulb temperature (Tw) -40 ... +140 °F Temperature (T) -40 ... +140 °F	Tw (°F) T (°F)

This page intentionally left blank.

CHAPTER 4

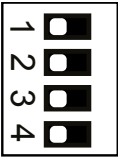
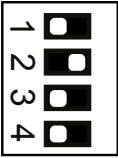
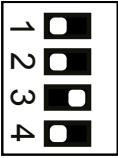
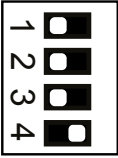
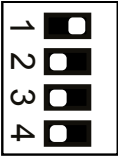
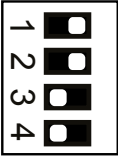
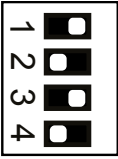
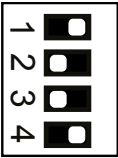
MAINTENANCE

This chapter provides information that is needed in basic maintenance of HMDW80 series.

Cleaning

The body of the transmitter can be cleaned by wiping with a moistened lint-free cloth. Do not use cleaning agents or solvents, or blow pressurized air into the transmitter housing or on the filter.

NOTE

Do not attempt to clean contaminated INTERCAP[®] sensors or filters. Instead, replace them with new parts. Filters and sensors can be purchased from Vaisala. For order codes, see section Spare Parts and Accessories on page 48.

Calibration

You can verify the performance of your HMDW80 series transmitter by comparing its reading with the reading from a portable reference instrument such as the HM70 Hand-Held Humidity and Temperature Meter. For operating instructions, refer to the documentation of your reference instrument.

If the comparison indicates that the reading from the transmitter is not within specification, the transmitter may need to have its filter and sensor replaced.

Replacing the INTERCAP® Humidity Sensor

HMDW80 series transmitters use the Vaisala INTERCAP® sensor for humidity measurement. The INTERCAP® sensor is designed to be replaced when necessary, and does not require adjustment by the user.

Replacing the INTERCAP® Sensor on Models HMD82/83 and HMW88/89

REQUIRED TOOLS

- New INTERCAP® humidity sensor.
- New filter (always recommended when replacing the sensor).
- Duct models only: medium size crosshead screwdriver (Pozidriv).

1. Power down the transmitter.
2. Duct models only: loosen the tightening screw on the fastening flange, and pull the probe out of the duct.
3. Remove the filter to access the sensors. See Figure 20 below.
4. Pull out the old INTERCAP® sensor, and insert the new one.
5. Insert the new filter.
6. Duct models only: push the probe back into the duct, to the same depth where it was before. Tighten the tightening screw on the fastening flange.
7. Power up the transmitter.
8. Verify that the transmitter now provides a valid humidity reading.

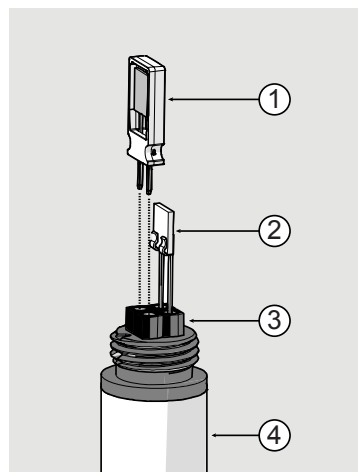

1305-024

Figure 20 Sensors on HMD82/83 and HMW88/89 Models

- 1 = Vaisala INTERCAP® sensor. Handle by the plastic frame.
- 2 = Temperature sensor. Do not touch or attempt to remove.
- 3 = Sensor socket.
- 4 = Transmitter probe.

Replacing the INTERCAP® Sensor on Wall Models HMW82/83

REQUIRED TOOLS

- New INTERCAP® humidity sensor.
- Small flat head screwdriver.

1. Use the screwdriver to push down on the tab on the top of the transmitter and open the transmitter cover.
2. Remove the old sensor, and insert the new one. See Figure 21 below.
3. Reconnect the cover to the mounting base.
4. Verify that the transmitter now provides a valid humidity reading.

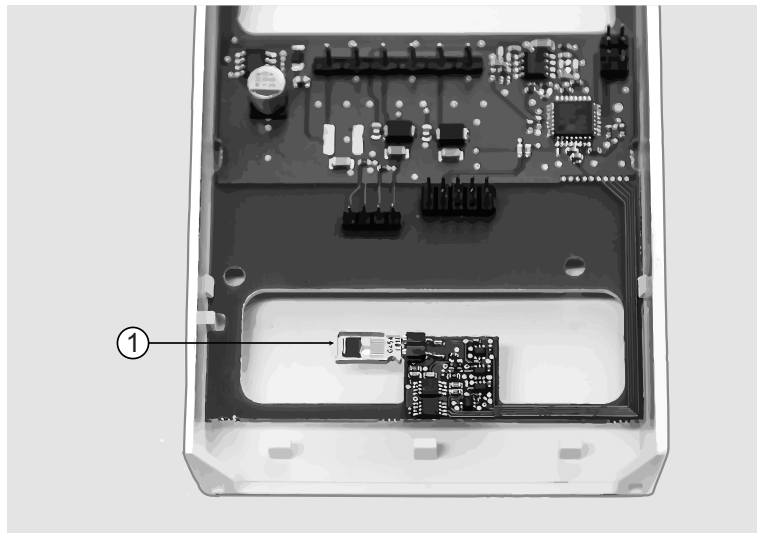

1305-018

Figure 21 INTERCAP® Sensor on HMW82/83 Models

Replacing the INTERCAP® Sensor on Outdoor Models HMS82/83

REQUIRED TOOLS

- New INTERCAP® humidity sensor.
- New filter (always recommended when replacing the sensor).
- Medium size crosshead screwdriver (Pozidriv)
- Flat head screwdriver
- 3 mm hex key (Allen key) for opening the radiation shield screws.
- If transmitter mounted on pole: 2.5 mm hex key for opening and tightening the set screw.

NOTE

You will need to remove the radiation shield to access the sensor, and this is difficult to do while the transmitter remains mounted on a pole or wall. The procedure below takes advantage of the detachable screw terminal to allow the cable to remain in place during the operation.

1. Power down the transmitter.
2. Open the transmitter cover and unplug the screw terminal. This allows you to leave the cable and cover at the installation site.

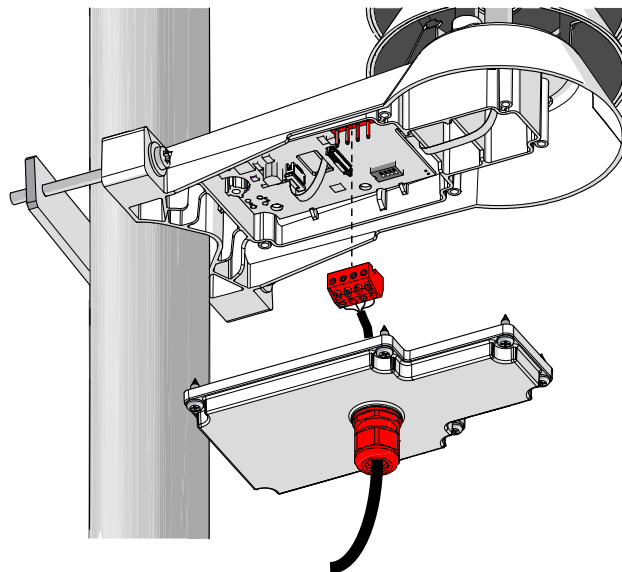

1305-019

Figure 22 Unplugging the Screw Terminal

3. Remove the transmitter from its installation point.

4. Open the two long screws that hold the radiation shield, and pull them out.

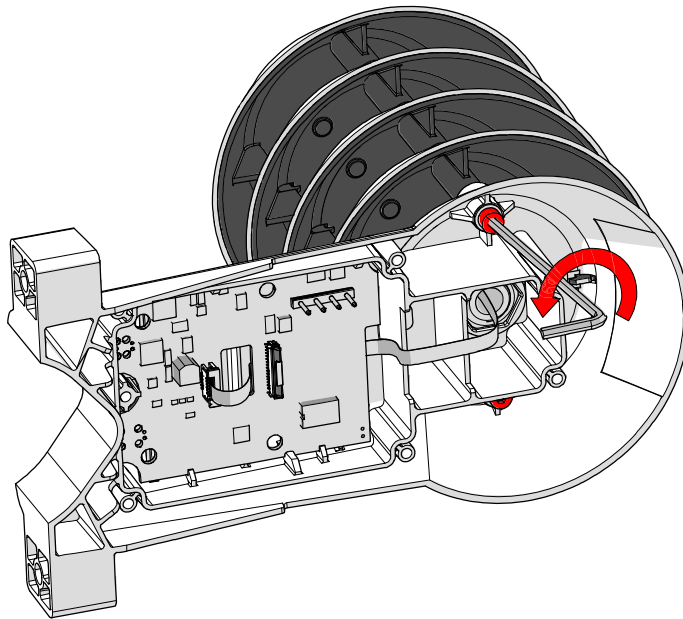

1305-020

Figure 23 Opening the Radiation Shield Screws

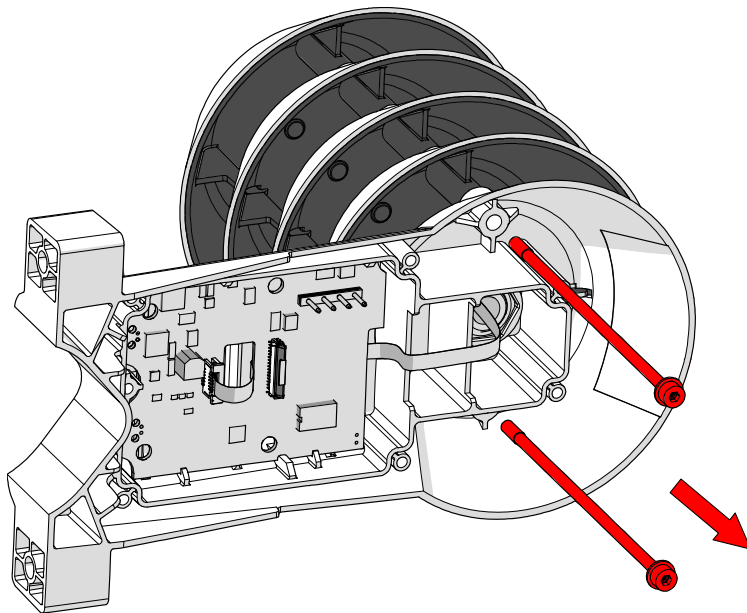

1305-021

Figure 24 Removing the Radiation Shield Screws

5. Use a flat head screwdriver to push on the visible plastic tab below the radiation shield.

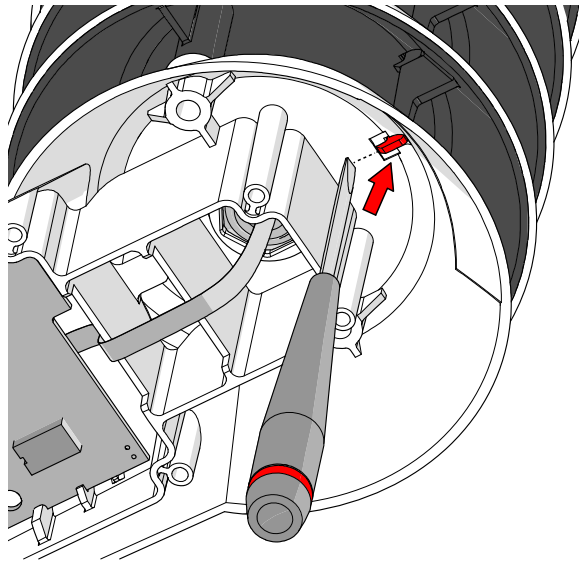

1305-022

Figure 25 Location of Locking Tab

6. Tilt the radiation shield away from the opened tab. This opens the second tab on the other side, allowing you to remove the radiation shield.

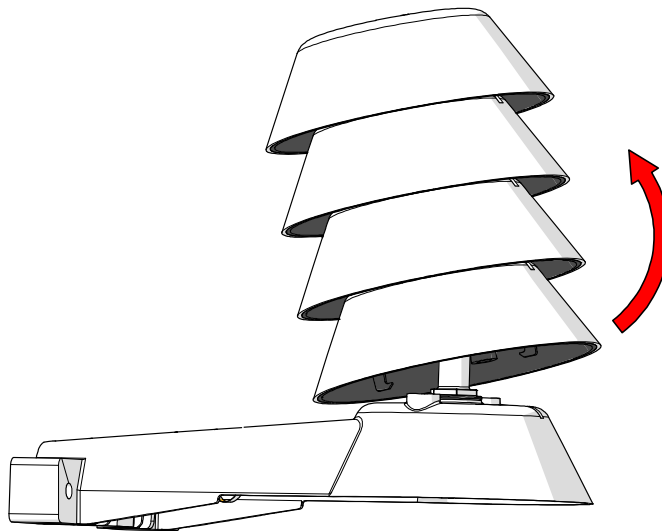

1305-023

Figure 26 Removing the Radiation Shield

7. Open the filter to expose the sensors.

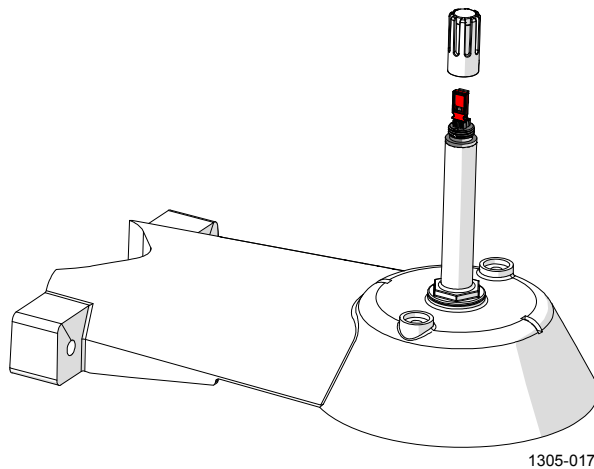

Figure 27 Filter Removed

8. Pull out the old INTERCAP[®] sensor, and insert the new one.

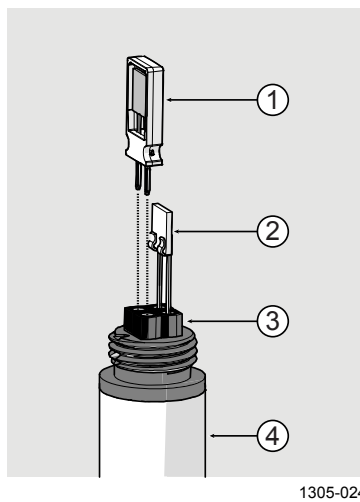

Figure 28 Sensors on HMS82/83 Models

- 1 = Vaisala INTERCAP[®] humidity sensor.
Handle by the plastic frame.
 - 2 = Temperature sensor. Do not touch or attempt to remove.
 - 3 = Sensor socket.
 - 4 = Transmitter probe.
9. Insert the new filter.
 10. Reassemble, remount, and reconnect the transmitter.
 11. Power up the transmitter.
 12. Verify that the transmitter now provides a valid humidity reading.

This page intentionally left blank.

CHAPTER 5

TROUBLESHOOTING

This chapter describes possible problems, their probable causes and remedies, and provides contact information for technical support.

Problem Situations

Table 7 Possible Problem Situations and Their Remedies

Problem	Probable Cause and Remedy
Transmitter outputs an incorrect humidity reading.	<ol style="list-style-type: none"> 1. Models with probes: check if the yellow transport protection cap has been left over the probe. Remove it if present. 2. Models with configurable output parameter: check that the desired output parameter has been selected using the DIP switches.
Temperature reading shown by the transmitter is too high.	<ol style="list-style-type: none"> 1. The transmitter may be installed in an unsuitable location, for example, near a heat source or in sunlight. Use a portable reference meter to check this. 2. HMW82 and HMW83: Check that the transmitter is installed in proper orientation, with the arrow on the mounting base pointing up.
Analog output reading is unchanging and incorrect.	The analog output channel may be in an error state. See section Analog Output Error State on page 42.

Analog Output Error State

HMDW80 series transmitters set the output channel(s) into a defined error level instead of the measured result in two situations:

- Transmitter detects a measurement malfunction. This means an actual measurement problem, such as sensor damage or unsuitable environmental conditions.
- Measured value(s) are well outside the scaled output range. For a more detailed explanation, see section Analog Output Overrange Behavior on page 16.

The error level depends on the output type:

- For 0 ... 10 V output, the error level is **11 V**.
HMW83 and TMW83 are an exception to this, their error level is **0 V**.
- For 4 ... 20 mA output, the error level is **3.6 mA**.

The transmitter resumes normal operation of the analog output(s) when the cause of the error state is removed.

Error Messages on the Display

Table 8 Error Messages on the Display

Error Message	Possible Cause and Solution
INTERNAL 1 INTERNAL 2 INTERNAL 3	Internal problem with the transmitter. Restart the transmitter to see if the problem remains. Contact Vaisala technical support if unable to remove the problem.
ERROR HUM	Humidity measurement failed. Check if the humidity sensor is damaged or missing.
ERROR T	Temperature measurement failed. Check if the temperature sensor is damaged or missing.

Technical Support

For technical questions, contact the Vaisala technical support by e-mail at helpdesk@vaisala.com. Provide at least the following supporting information:

- Name and model of the product in question
- Serial number of the product
- Name and location of the installation site
- Name and contact information of a technically competent person who can provide further information on the problem.

Product Returns

If the product must be returned for service, see www.vaisala.com/returns.

For contact information of Vaisala Service Centers, see www.vaisala.com/servicecenters.

This page intentionally left blank.

CHAPTER 6

TECHNICAL DATA

This chapter provides the technical data of the HMDW80 series.

Specifications

Table 9 Specifications for HMW82/83 and TMW82/83

Property	Description / Value
Operating environment	
Operating temperature range	-5 ...+55 °C (+23 ... +131 °F)
Operating humidity range	0 ...100 %RH, non-condensing
Relative humidity	
Measurement range	0 ... 100 %RH
Accuracy	
Temperature range +10 ... +30 °C (+50 ... +86 °F)	
30 ... 70 %RH	±3 %RH
0 ... 30 %RH, 70 ... 100 %RH	±5 %RH
Temperature range -5 ... +10 °C, +30 ... + 55 °C (+23 ... +50 °F, +86 ... +131 °F)	
0 ...100 %RH	±7 %RH
Stability in typical HVAC applications	±2 %RH over 2 years
Humidity sensor	Vaisala INTERCAP®
Temperature	
Measurement range	-5 ...+55 °C (+23 ... +131 °F)
Accuracy	
+10 ... +30 °C (+50 °F ... +86 °F)	±0.5 °C (±0.9 °F)
-5 ... +10 °C, +30 ... +55 °C (+23 ... +50 °F, +86 ... +131°F)	±1.0 °C (±1.8 °C)
Temperature sensor	Digital temperature sensor

Table 10 Specifications for HMD82/83, TMD82/83, HMW88/89, and HMS82/83

Property	Description / Value
Operating environment	
Operating temperature range	-40 ...+60 °C (-40 ... +140 °F)
Operating humidity range	0 ...100 %RH
Relative humidity	
Measurement range	0 ... 100 %RH
Accuracy	
Temperature range +10 ... +30 °C (+50 ... +86 °F)	
0 ... 90 %RH	±3 %RH
90 ... 100 %RH	±5 %RH
Temperature range -20 ... +10 °C, +30 ... +60 °C (-4 ... +50 °F, +86 ... +140 °F)	
0 ... 90 %RH	±5 %RH
90 ... 100 %RH	±7 %RH
Temperature range -40 ... -20 °C (-40 ... -4 °F)	
0 ... 100 %RH	±7 %RH
Stability in typical HVAC applications	±2 %RH over 2 years
Humidity sensor	Vaisala INTERCAP®
Temperature	
Measurement range	-40 ...+60 °C (-40 ... +140 °F)
Accuracy	
At +20 °C (+68 °F)	±0.3 °C (±0.54 °F)
Temperature dependence	±0.01 °C/°C
Temperature sensor	Pt1000 RTD Class F0.1 IEC 60751
Calculated parameters	
Measurement range for dewpoint temperature and wet bulb temperature	-40 ...+60 °C (-40 ... +140 °F)
Measurement range for enthalpy	-40...460 kJ/kg (-10...+190 BTU/lb)

Table 11 Specifications for HMD82/83D and HMW88/89D

Property	Description / Value
Operating environment	
Operating temperature range	-5 ... +60 °C (+23 ... +140 °F)
Operating humidity range	0...100 %RH, non-condensing
Relative humidity	
Measurement range	0 ... 100 %RH
Accuracy	
Temperature range +10 ... +30 °C (+50 ... +86 °F)	
0 ... 90 %RH	±3 %RH
90 ... 100 %RH	±5 %RH
Temperature range -5 ... +10 °C, +30 ... +60 °C (+23 ... +50 °F, +86 ... +140 °F)	
0 ... 90 %RH	±5 %RH
90 ... 100 %RH	±7 %RH
Stability in typical HVAC applications	±2 %RH over 2 years
Humidity sensor	Vaisala INTERCAP®
Temperature	
Measurement range (Analog output scaling)	-40 ... +60 °C (-40 ... +140 °F)
Operating temperature range of the display	-5 ... +60 °C (+23 ... +140 °F)
Accuracy	
At +20 °C (+68 °F)	±0.3 °C (±0.54 °F)
Temperature dependence	±0.01 °C/°C
Temperature sensor	Pt1000 RTD Class F0.1 IEC 60751
Calculated parameters	
Measurement range for dewpoint temperature and wet bulb temperature	-40 ... +60 °C (-40 ... +140 °F)
Measurement range for enthalpy	-40...460 kJ/kg (-10...+190 BTU/lb)

Table 12 Operating Environment (All Models)

Property	Description / Value
Operating environment	See model specifications
Maximum wind/flow speed	30 m/s
Storage temperature	-40 ... +60 °C (-40 ... +140 °F)
Electromagnetic compliance	EN61326-1, industrial environment

Table 13 Inputs and Outputs

Property	Description / Value
Current output models (2-wire)	
Outputs	4 ... 20 mA, loop powered
Loop resistance	0 ... 600 Ω
Supply voltage	20 ... 28 VDC at 600 Ω load 10 ... 28 VDC at 0 Ω load
Voltage output models (3-wire)	
Outputs	0 ... 10 V
Load resistance	10 kΩ min
Supply voltage	18 ... 35 VDC 24 VAC ±20 % 50/60 Hz

Table 14 Mechanics

Property	Description / Value
Max. wire size	1.5 mm ² (AWG 16)
Standard housing color	White (RAL9003)
Housing material	ABS/PC (UL-V0 approved)
HMW82/83, TMW82/83 HMW88/89(D), HMD82/83(D), TMD82/83, HMS82/83	PC + 10%GF (UL-V0 approved)

Spare Parts and Accessories

Table 15 HMDW80 Series Spare Parts and Accessories

Description	HMD82/83	TMD82/83	HMW82/83	TMW82/83	HMW88/89	HMS82/83	Item Code
Sensors							
Vaisala INTERCAP [®] humidity sensor, 1 piece	•		•		•	•	15778HM
Vaisala INTERCAP [®] humidity sensor, 10 pcs	•		•		•	•	INTERCAPSET-10PCS
Sensor protection							
PTFE membrane filter	•	•				•	ASM210856SP
PTFE filter					•		DRW239993SP
Accessories and Spare Parts							
Fastening flange assembly (screws included)	•	•					ASM210771SP
Cable gland with O-ring	•	•			•	•	CABLEGLANDORING
Lid assembly with window for display (screws included)	•	•			•		ASM210793SP
Conduit fitting + O-ring (M16x1.5 / NPT1/2 Inch)	•	•			•	•	210675SP
Conduit fitting + O-ring (M16x1.5 / PG9, RE-MS)	•	•			•	•	210674SP

• = Part is compatible

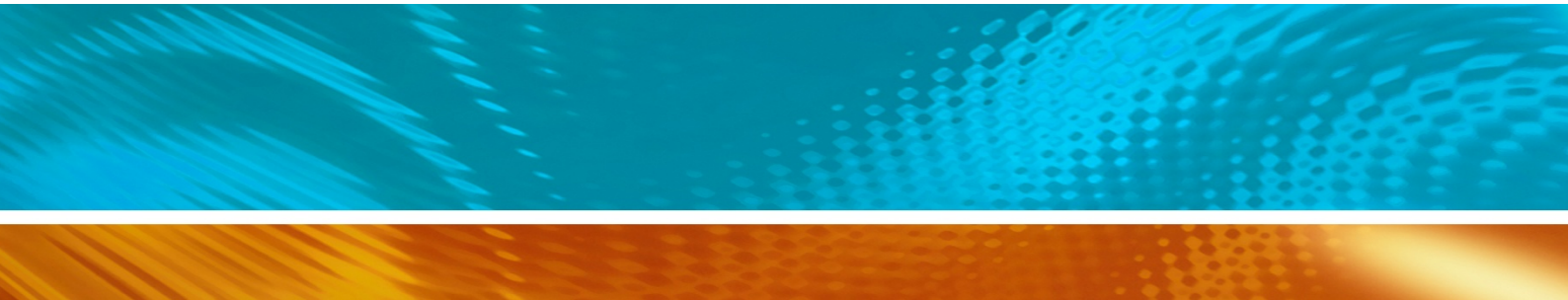

www.vaisala.com

