

de Mischhahn und Antrieb
 fr Robinet mélangeur et servomoteur
 en Mixing cock and actuator
 it Valvola e servomotore
 es Válvula de sector y servomotor
 sv Blandningsventil och drivning
 nl Mengkraan en servomotor

de Montagevorschrift
 fr Instruction de montage
 en Fitting instructions
 it Istruzioni di montaggio
 es Instrucciones de montaje
 sv Monteringsanvisning
 nl Montagevoorschrift

M3R, M4R
 ASM 105S, ASM 115S,
 ASM 124S, AR30 W

MH32F
 ASM 105S, ASM 115S,
 ASM 124S, AR30 W

MH42F
 ASM 124S, AR30 W

de Installationsanweisung für die Elektrofachkraft
 fr Notice d'installation pour l'électricien
 en Guidelines for the electrician
 it Informazioni per l'installatore elettrico
 es Instrucciones de instalación para el electricista
 sv Installationsinstruktion för behörig elektriker
 nl Installatie aanwijzing voor de elektromonteur

M3R, M4R

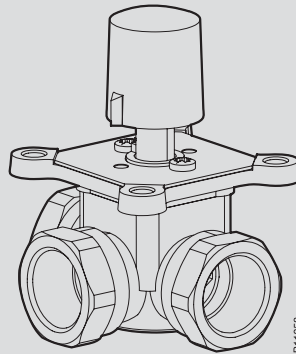

B11858

MH32F, MH42F

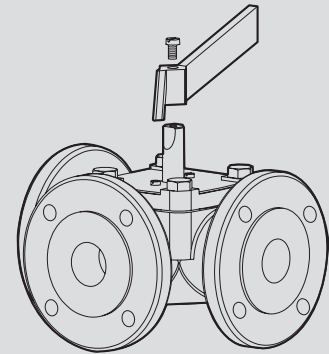

B12732

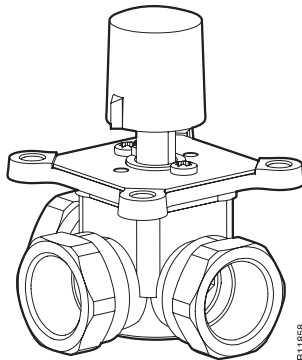
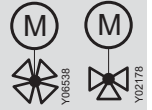

B11858

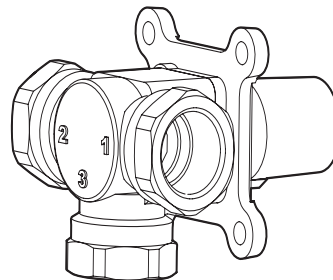

B12754

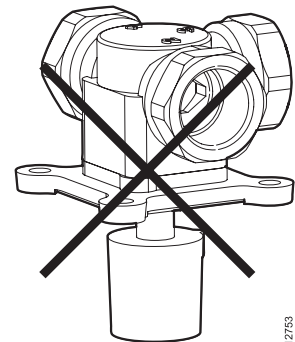

B12753



ASM 105S
 ASM 115S

ASM 124S

AR30 W

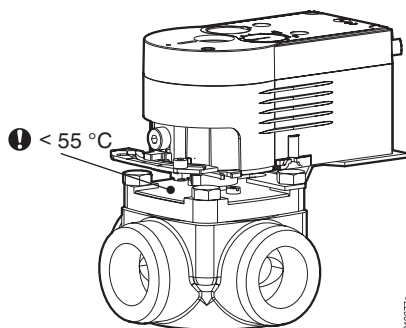

B10077a

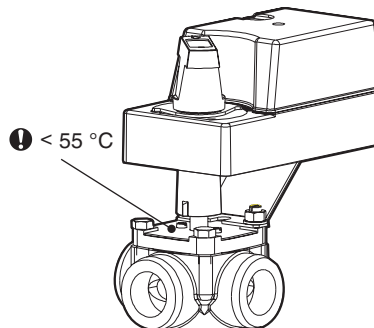

B10077a

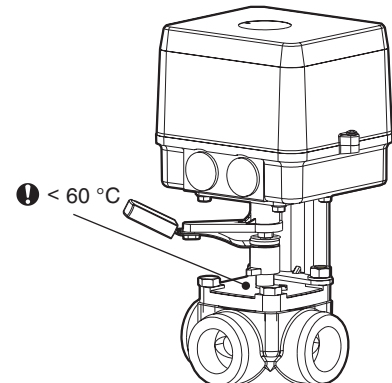

B10078a

	ASM 105S, ASM 115S	ASM 124S	AR30 W
M3R, M4R	✓	✓	✓
MH32F (DN 100...150), MH42F	✗	✓	✓
MH32F (DN 20...80)	✓	✓	✓

1

VORSICHT Verbrunnungsgefahr durch heiße Anlagenteile. Nur an abgekühlter Anlage arbeiten.

ATTENTION Risque de brûlure en raison de pièces chaudes. Travailler uniquement sur une installation refroidie.

CAUTION Risk of burns due to hot system components. Only work on cooled systems.

ATTENZIONE Pericolo di ustioni dovuto a componenti caldi dell'impianto. Operare solo se l'impianto è raffreddato.

ATENCION Riesgo de sufrir quemaduras por contacto con componentes de la instalación. Trabaje en las instalaciones únicamente cuando se hayan enfriado.

OBSERVER Heta ytor på anläggningen utgör risk en för brännskador. Arbeteten på anläggningen får endast utföras när anläggningen svalnat.

VOORZICHTIG Verbrandingsgevaar door hete installatiedelen. Voer alleen werkzaamheden uit aan een afgekoelde installatie.

VORSICHT Verletzungsgefahr durch unter Druck stehende Ventile. Nur an drucklosen Ventilen arbeiten.

ATTENTION Risque de blessure en raison de vannes sous pression. Travailler uniquement sur des vannes sans pression.

CAUTION Risk of injury due to valves under pressure. Only work on unpressurised valves.

ATTENZIONE Pericolo di ferimento dovuto a valvole sotto pressione. Operare solo se le valvole sono depressurizzate.

ATENCION Riesgo de sufrir lesiones debidas a válvulas bajo presión. Trabaje únicamente en válvulas sin presión.

OBSERVER Trycksatta ventiler utgör en risk för personskador. Arbeten på ventiler får endast utföras när ventilerna inte är trycksatta.

VOORZICHTIG Gevaar voor letsel door onder druk staande afsluiters. Voer alleen werkzaamheden uit aan drukloze afsluiters.

2.1 2.2a, 2.2b

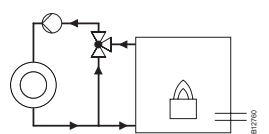
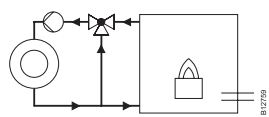
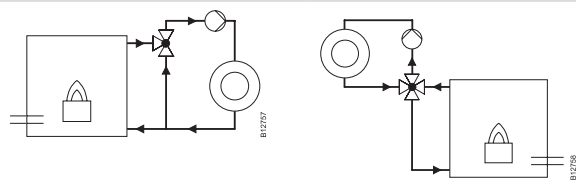
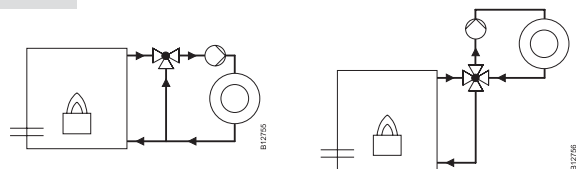

M3R, M4R

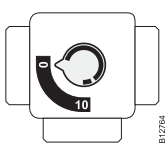
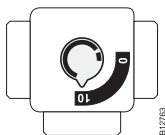
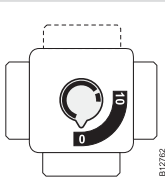
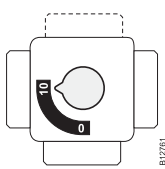

MH32F

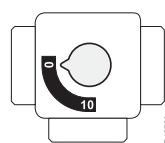
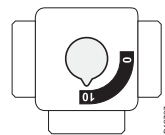
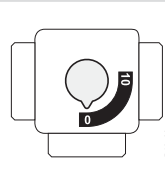
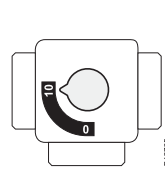

MH42F

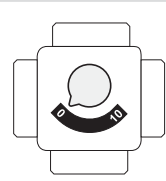
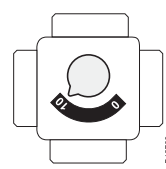

2.2a M3R, M4R

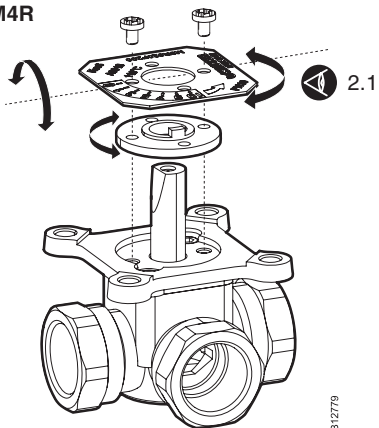

2.2b MH32F, MH42F

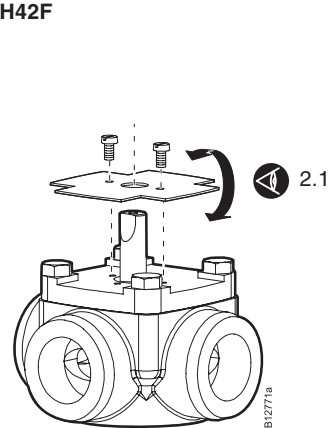

3a.1

AR30 W

036177500

de Zubehör
fr Accessoire
en Accessory
it Accessorio
es Accesorios
sv Tillbehör
nl Toebehoren

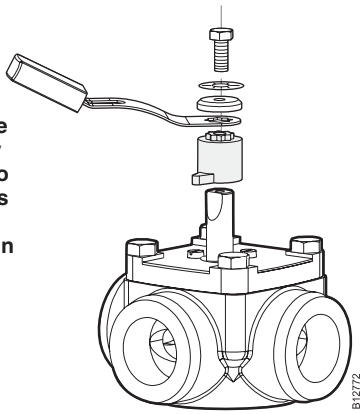

M3R, M4R / MH32F

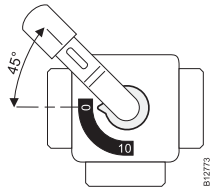

MH42F

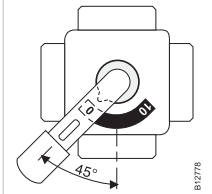
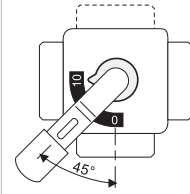
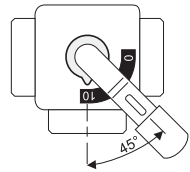
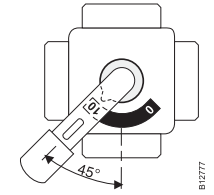
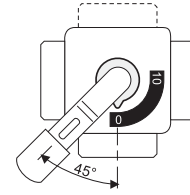

3a.2

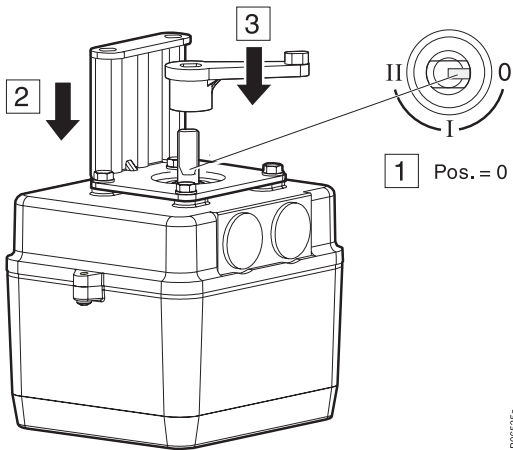

3a.3

036177500
de Zubehör
fr Accessoire
en Accessory
it Accessorio
es Accesorios
sv Tillbehör
nl Toebehoren

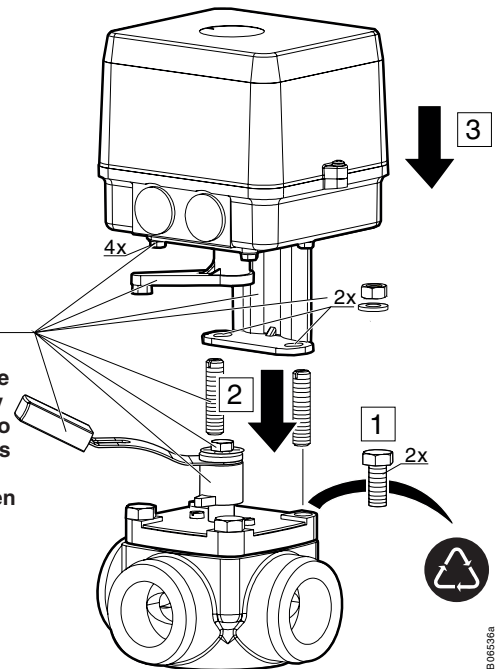

3a.4

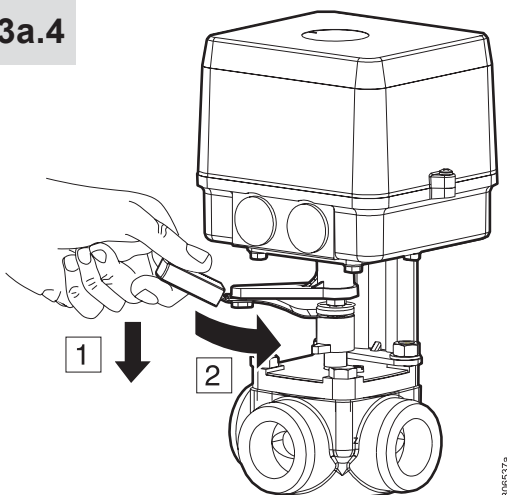

3b ASM 105S, ASM 115S

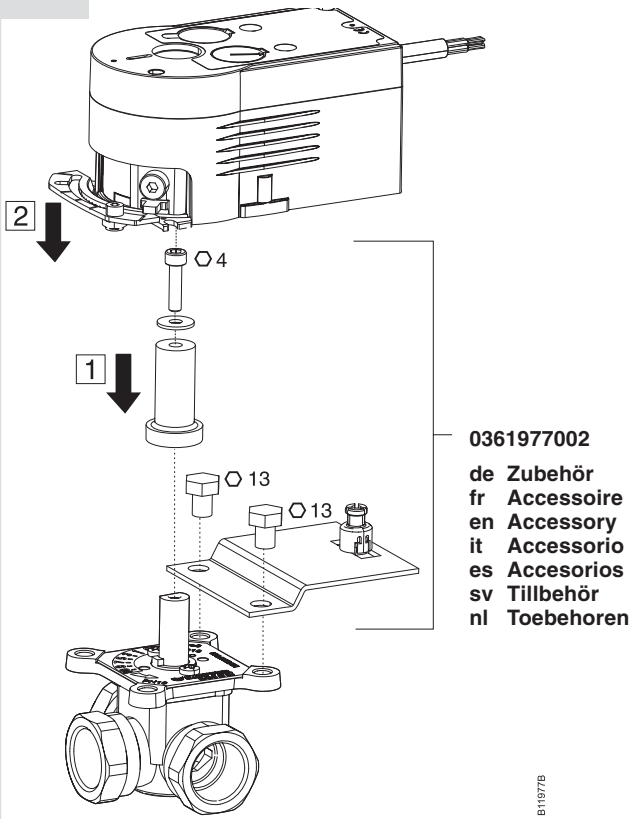

3c.1 ASM 124S

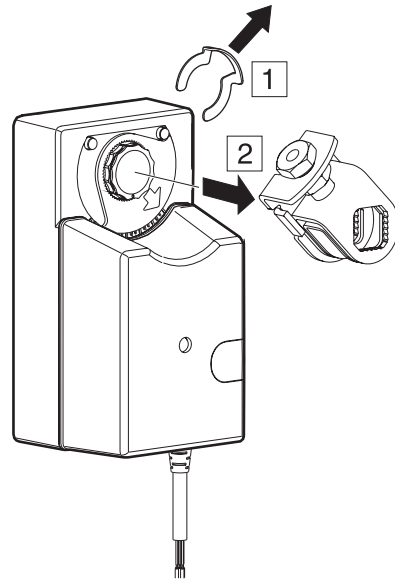

3c.2

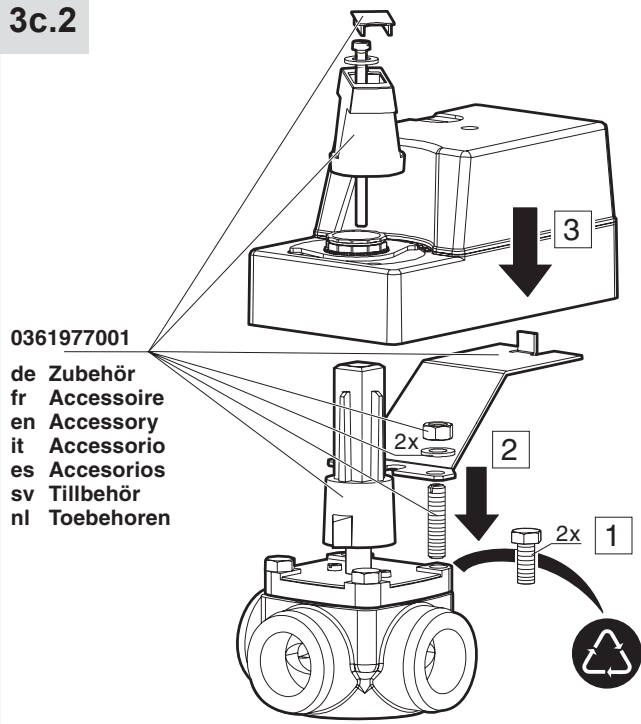

3c.3

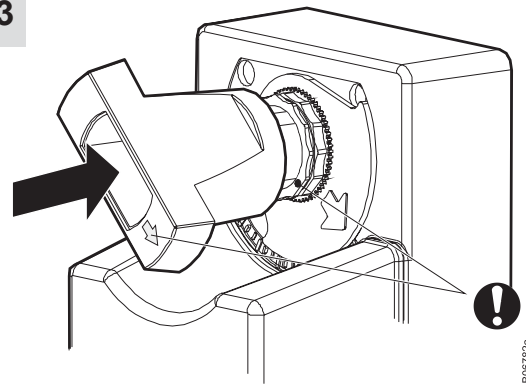

3c.4

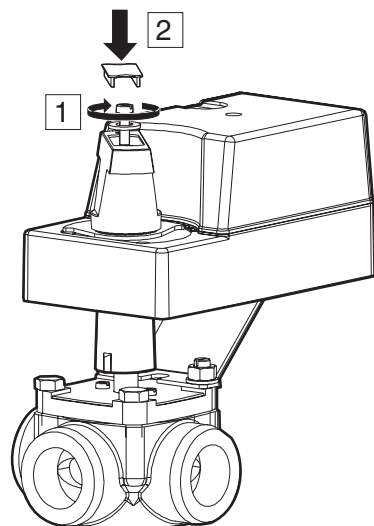



HINWEIS Allgemeine Montageangaben

- Montage, Inbetriebnahme und Wartung darf nur durch qualifiziertes Personal erfolgen.
- Einbau der Armatur im Rohrleitungssystem muss frei von mechanischen Spannungen erfolgen.
- Armatur darf nicht als Festpunkt benützt werden, sie wird vom Rohrleitungssystem getragen.
- Armatur und Rohrleitungen müssen frei von Schmutz, Schweissperlen usw. sein.
- Bei Demontage der Armatur muss Rohrleitungssystem drucklos, Medium abgekühlt und Anlage entleert sein.

AVIS Remarques concernant le montage

- Montage, mise en service et maintenance doivent uniquement être effectués par du personnel qualifié.
- Le système de conduites doit être exempt de tensions mécaniques lors du montage de la vanne.
- Ne pas utiliser la vanne comme point de fixation, car elle est portée par le système de conduites.
- La vanne et les conduites doivent être propres et exemptes de perles de soudure etc.
- Avant le démontage de la vanne, vérifier que le système de conduites soit exempt de pression, que le liquide soit refroidi et que l'installation soit vidangée.

NOTICE Fitting guidelines

- Fitting, commissioning and servicing should be carried out only by qualified personnel.
- There should be no mechanical tension in the pipework when the valve is fitted.
- The valve should not be used as a fixation point; it is supported by the pipework.
- The valve and the pipes must be free of dirt, welding beads etc.
- Before removing the valve: (i) the piping must not be under pressure; (ii) the medium must have cooled down; and (iii) the system must be drained.

AVVISO Dati generali per il montaggio

- Montaggio, messa in servizio e manutenzione vanno effettuati solo da parte di personale qualificato.
- Il montaggio della valvola deve avvenire in modo che non si generino tensioni nel sistema di tubazioni.
- La valvola deve venire supportata solo dal sistema di tubazioni, e pertanto non va fissata su sostegni fissi.
- La valvola e il sistema di tubazioni devono essere liberi da polvere, perle di saldatura ecc.
- Nello smontaggio della valvola il sistema di tubazioni deve essere senza pressione, il fluido raffreddato e l'impianto svuotato.

AVISO Indicaciones para el montaje

- El montaje, puesta en marcha y servicio de reparaciones debe ser realizado sólo por personal cualificado.
- No debe haber tensión mecánica en la tubería cuando se monta la válvula.
- La válvula no debe utilizarse como un punto de fijación, está soportada por la tubería.
- La válvula y las tuberías deben estar libres de suciedad, restos de soldaduras, etc.
- Antes de sacar la válvula: (i) la tubería no debe estar bajo presión; (ii) el fluido debe enfriarse; y (iii) el sistema debe ser vaciado.

OBS ! Montageinstruktioner

- Montage, idrifttagning och service skall endast ske med kvalificerad personal.
- Montringen av ventilen i rörsystemet måste göras utan mekaniska spänningar
- Ventilen skall ej användas som fästpunkt, den skall stödjas av rörsystemet.
- Ventilen och rörledningen måste vara fria från smuts, svetstrådar osv.
- Före demontage av ventilen måste: rörledningen vara trycklös, mediet måste vara avkyllt och anläggningen måste vara nedtömd.

LET OP Algemene montage-instructies

- Montage, inbedrijfstelling en onderhoud mogen alleen door gekwalificeerd personeel worden uitgevoerd.
- Het ventiel dient spanningsvrij in het buisleidingnetwerk te worden geïnstalleerd.
- Het ventiel mag niet als vast punt worden gebruikt, het wordt door het buisleidingnetwerk gedragen.
- Het ventiel moet vrij van vuil en lasparels enz. zijn.
- Voor de demontage van het ventiel buisleidingsstelsel drukvrij maken, medium volledig af laten koelen en de installatie leeg laten lopen.



de www.sauter-controls.com ➔ Produkte ➔ MD Datenblatt.
 fr www.sauter-controls.com ➔ Produits ➔ Fiche MD.
 en www.sauter-controls.com ➔ Products ➔ MD Datasheet.
 it www.sauter-controls.com ➔ Products ➔ MD Datasheet.
 es www.sauter-controls.com ➔ Products ➔ MD Datasheet.
 sv www.sauter-controls.com ➔ Products ➔ MD Datasheet.
 nl www.sauter-controls.com ➔ Products ➔ MD Datasheet.

de Dokument aufbewahren
 fr Ce document est à conserver
 en Retain this document
 it Conservare il documento
 es Guardar el documento
 sv Spara dokumentationen
 nl Document bewaren

© Fr. Sauter AG
 Im Surinam 55
 CH-4016 Basel
 Tel. +41 61 - 695 55 55
 Fax +41 61 - 695 55 10
www.sauter-controls.com
info@sauter-controls.com