



TLSZ Guardmaster Guard Locking Switch

Catalog Numbers 440G-TZS21UPRH, 440G-TZS21UPLH,
440G-TZS21UTRH, 440G-TZS21UTLH



Allen-Bradley

by ROCKWELL AUTOMATION

Guardmaster[®]

User Manual

Original Instructions

Important User Information

Read this document and the documents listed in the additional resources section about installation, configuration, and operation of this equipment before you install, configure, operate, or maintain this product. Users are required to familiarize themselves with installation and wiring instructions in addition to requirements of all applicable codes, laws, and standards.

Activities including installation, adjustments, putting into service, use, assembly, disassembly, and maintenance are required to be carried out by suitably trained personnel in accordance with applicable code of practice.

If this equipment is used in a manner not specified by the manufacturer, the protection provided by the equipment may be impaired.

In no event will Rockwell Automation, Inc. be responsible or liable for indirect or consequential damages resulting from the use or application of this equipment.

The examples and diagrams in this manual are included solely for illustrative purposes. Because of the many variables and requirements associated with any particular installation, Rockwell Automation, Inc. cannot assume responsibility or liability for actual use based on the examples and diagrams.

No patent liability is assumed by Rockwell Automation, Inc. with respect to use of information, circuits, equipment, or software described in this manual.

Reproduction of the contents of this manual, in whole or in part, without written permission of Rockwell Automation, Inc., is prohibited.

Throughout this manual, when necessary, we use notes to make you aware of safety considerations.



WARNING: Identifies information about practices or circumstances that can cause an explosion in a hazardous environment, which may lead to personal injury or death, property damage, or economic loss.



ATTENTION: Identifies information about practices or circumstances that can lead to personal injury or death, property damage, or economic loss. Attentions help you identify a hazard, avoid a hazard, and recognize the consequence.

IMPORTANT Identifies information that is critical for successful application and understanding of the product.

These labels may also be on or inside the equipment to provide specific precautions.



SHOCK HAZARD: Labels may be on or inside the equipment, for example, a drive or motor, to alert people that dangerous voltage may be present.



BURN HAZARD: Labels may be on or inside the equipment, for example, a drive or motor, to alert people that surfaces may reach dangerous temperatures.



ARC FLASH HAZARD: Labels may be on or inside the equipment, for example, a motor control center, to alert people to potential Arc Flash. Arc Flash will cause severe injury or death. Wear proper Personal Protective Equipment (PPE). Follow ALL Regulatory requirements for safe work practices and for Personal Protective Equipment (PPE).

The following icon may appear in the text of this document.



Identifies information that is useful and can help to make a process easier to do or easier to understand.

| | | |
|--|---|----|
| | About This Publication | 5 |
| | Who Should Use This Manual | 5 |
| | Summary of Changes..... | 5 |
| | Additional Resources | 5 |
| | Terminology..... | 6 |
| | Chapter 1 | |
| General Description | Guardmaster TLSZ Guard Locking Switch Overview..... | 7 |
| | Catalog Number Explanation | 7 |
| | Packaging Contents | 8 |
| | Chapter 2 | |
| Installation | General Considerations..... | 9 |
| | Actuator/Target Mounting..... | 9 |
| | Allowable Approach Directions | 9 |
| | Minimum Operating Radius | 10 |
| | Manual Release | 10 |
| | Manual Override Cover | 11 |
| | Pair Proximity | 11 |
| | Guide Repositioning | 11 |
| | Steel Locking Bolts | 12 |
| | Actuator Clearance | 12 |
| | Approximate Dimensions..... | 13 |
| | Chapter 3 | |
| Wiring | Connections..... | 15 |
| | OSSD Inputs | 15 |
| | OSSD Outputs..... | 15 |
| | Auxiliary Output | 16 |
| | Lock Command..... | 16 |
| | Chapter 4 | |
| Commissioning | Preparation | 17 |
| | First Time Power-up | 18 |
| | Learn First Target..... | 18 |
| | Learn Additional Targets | 18 |
| | Commissioning Errors | 19 |
| | Power-up Self-check..... | 19 |
| | Chapter 5 | |
| Functional Testing | Testing Procedure..... | 21 |
| | Chapter 6 | |
| Application and Wiring Examples | Wiring to GLP Relay..... | 23 |
| | Circuit Status as Shown | 24 |

**Diagnostics and
Troubleshooting**

Wiring to GLT Relay 24
 Circuit Status as Shown 25
Wiring to DI and EMD Relay 26
 Circuit Status as Shown 27
Wiring to DG Relay 27
Wiring to CR30 Software Configurable Safety Relay 28
Wiring to 1734 POINT Guard I/O 31
Wiring to 1732 ArmorBlock 35

Chapter 7

Tools Needed 39
 Required Tools 39
 Optional Tools 39
Flowchart 40
Step 1 — Status
Indicator Off 40
Step 2 — Status Indicator Flashing Red at 4 Hz 41
 Wrong Target 41
 Missing Target 41
 Target Not Mounted Correctly 42
 Pair Proximity 42
 Mechanical Pressure on Safety Gate 42
 Long Wiring 43
 Voltage Supply Dips 44
 Rapid Locking 44
Step 3 - Status Indicator Flashes Red at 1 Hz 45
 Capacitive Loading 45
Step 4 — Status Indicator Flashes Green at 1 Hz 46
 Corrective Action: 46
Step 5 — Flashing Red and Green 46
Step 6 — Indicator Steady Red 46
Step 7 — Other Considerations 46
 Distribution Block 46
 GSR Relays on Power-up 48

Specifications

Appendix A

Safety Ratings 49
Operating Characteristics 49
Environmental 50
General 50
Declaration of Conformity 50
 CE Conformity 50
 UKCA Conformity 50

Index 51

About This Publication

This manual is a reference guide for the Guardmaster® TLSZ guard locking switch. This manual:

- Explains how to install and wire your TLSZ guard locking switch.
- Provides an overview of the Guardmaster TLSZ guard locking switch.

Who Should Use This Manual

Use this manual to design, install, program, or troubleshoot systems that use the TLSZ Guardmaster guard locking safety switches.

You are required to have a basic understanding of electrical circuitry and familiarity with safety-related control systems. If you do not, obtain the proper training before using this product.

Summary of Changes

This publication contains the following new or updated information. This list includes substantive updates only and is not intended to reflect all changes.

| Topic | Page |
|---|------|
| Updated Terminology table. | 6 |
| Updated Catalog Number Explanation section. | 7 |
| Added UKCA certification to Safety Ratings table. | 49 |
| Added Declaration of Conformity section. | 50 |

Additional Resources

These documents contain additional information concerning related products from Rockwell Automation.

| Resource | Description |
|--|--|
| Guardmaster Configurable Safety Relay Wiring Diagrams, publication 440C-WD001 | Provides example wiring diagrams for the CR30 software configuration safety relay. |
| Industrial Automation Wiring and Grounding Guidelines, publication 1770-4.1 | Provides general guidelines for installing a Rockwell Automation® industrial system. |
| Functional Safety Data Sheet, publication SAFETY-SR001 | Provides functional safety data and details for Rockwell Automation products. |
| Industrial Automation Glossary, publication AG-7.1 | Glossary of industrial automation terms and abbreviations |
| Product Certifications website, rok.auto/certifications . | Provides declarations of conformity, certificates, and other certification details. |

You can view or download publications at rok.auto/literature.

Terminology

The [Industrial Automation Glossary](#) contains terms and abbreviations that are used by Rockwell Automation to describe industrial automation systems. [Table 1](#) lists specific terms and abbreviations that are used in this manual.

Table 1 - Terminology

| Term | Description |
|---------------------------------------|---|
| NC | No connection |
| N.C. (Normally Closed) | An electrical contact whose normal state (for example, no pressure or electrical potential applied) is in the closed position. |
| N.O. (Normally Open) | An electrical contact whose normal state (such as no pressure or electrical potential applied) is in the open position. |
| PLC | A programmable logic controller or a programmable automation controller. |
| PTL (Power to Lock) | Apply 24V to the lock command to lock the switch. This command applies to the TLSZL guard locking switch. |
| PTR (Power to Release) | Apply 24V to the lock command to unlock the switch. This command applies to the TLSZR guard locking switch. |
| Reaction Time | Describes the time between the true state of the input to the on state of the output. |
| Response Time | Describes the time between the trigger of the input to the off state of the output. Throughout this manual, the safety outputs are described as turning off immediately (turning off within the response time). |
| RFID | Radio frequency identification. |
| OSSD (Output Signal Switching Device) | Typically a pair of solid-state signals pulled up to the DC source supply. The signals are tested for short circuits to the DC power supply, short circuits to the DC common, and short circuits between the two signals. |
| Standard coding | Same as low coding as defined in EN ISO 14119:2013 |
| TLSZL | TLSZ Power to Lock guard locking switch |
| TLSZR | TLSZ Power to Release guard locking switch |
| Unique coding | Same as high coding as defined in EN ISO 14119:2013 |

General Description

Guardmaster TLSZ Guard Locking Switch Overview

This Guardmaster® TLSZ guard locking switch functions by locking its actuator, which prohibits the opening of a guard.

The TLSZ guard locking switch uses radio frequency identification, RFID, coding to detect the appropriate target.

This version of the Guardmaster TLSZ guard locking switch features OSSD outputs. These outputs are enabled only when the actuator is locked and the RF target is sensed.

This device is intended to be part of the safety-related control system of a machine. Perform a risk assessment before installation to determine whether the specifications of this device are suitable for all operational and environmental characteristics of the machine. See [Specifications on page 49](#) for certification information and ratings.

Use nonremovable screws, bolts, or nuts to mount the switch and actuators. Do not over torque the mounting hardware.

TLSZ guard locking switches are classified according to ISO 14119 as Type 4 switching devices. The RFID targets are classified as having a high level of coding.

Take measures to minimize the need to defeat and to manage the use and availability of spare RFID targets.

Catalog Number Explanation

440
a
G - T
b c
Z
d
S21
e
U
f
P
g
R
h
H
i

| a | |
|------|------------------------|
| Code | Description |
| 440 | Safeguards the product |

| b | |
|------|----------------------|
| Code | Description |
| G | Guard locking switch |

| c | |
|------|----------------------|
| Code | Description |
| T | Titan locking switch |

| d | |
|-----------|--------------------------------------|
| Lock Type | |
| Code | Description |
| Z | PLe rated, cascadable safety signals |

| e | |
|-----------------|---|
| Connection Type | |
| Code | Description |
| S21 | Solid-state outputs, 2 safety (OSSD), 1 aux |

| f | |
|------------------|--------------------------|
| Special Features | |
| Code | Description |
| U | Unique coded RFID target |

| g | |
|-----------|------------------------------|
| Lock Type | |
| Code | Description |
| P | Aux signal shows lock status |
| T | Aux signal shows door status |

| h | |
|-----------------|------------------|
| Connection Type | |
| Code | Description |
| R | Power to Release |
| L | Power to Lock |

| i | |
|------------------|------------------------|
| Special Features | |
| Code | Description |
| H | 8-pin M12 QD connector |



ATTENTION: Guard locking switches that use the Power to Lock principle can only be used after a risk assessment shows that the Power to Release principle is inappropriate for the application. If a power supply loss occurs with Power to Lock switches, the switches immediately unlock and you can access the hazards.

Packaging Contents

Figure 1 shows the contents in the shipping package. The contents include:

- Switch
- Actuator
- RFID target
- T20 security Torx bit
- Two steel bolts and nuts
- Plug
- Installation instructions (not shown)

Figure 1 - Package Contents

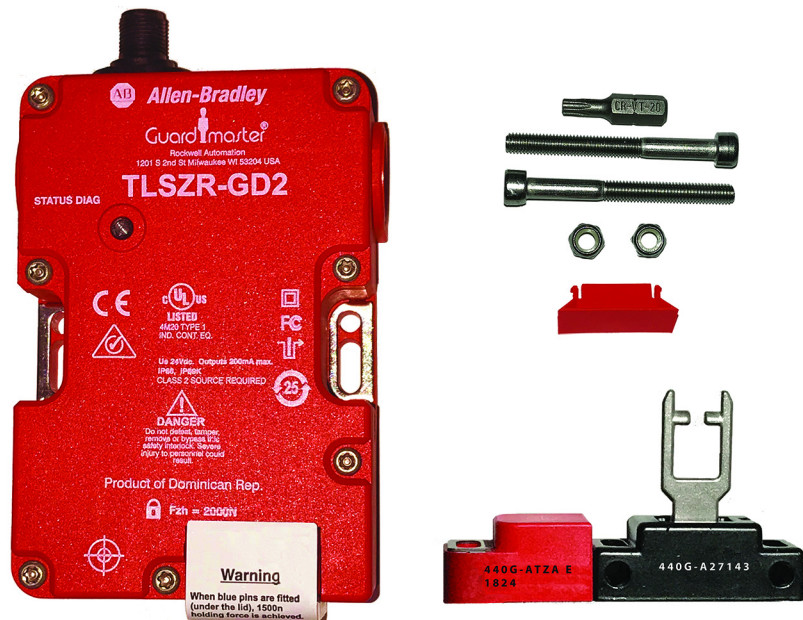

Installation

General Considerations

The TLSZ guard locking switch is designed for use on guards that are engineered to be rigid and without sag. The TLSZ guard locking switch uses radio frequency identification (RFID) coding to detect the appropriate target.

Actuator/Target Mounting

[Figure 2](#) shows the correct and incorrect ways to mount the target with the actuator.

The TLSZ guard locking switch must only be used with the fully flexible actuator. The replacement part number for the actuator is catalog number 44OG-A27143.

Figure 2 - Target/Actuator Mounting

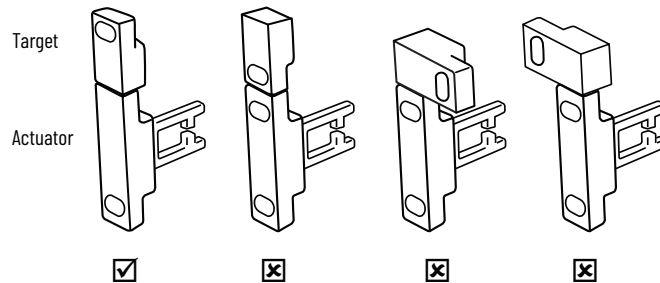

Allowable Approach Directions

The actuator and target must be always mounted as “close coupled” and can approach the switch in any of the three entry slot positions that are shown in [Figure 3](#). Approach from the underside is not allowed, as the distance from the target to the internal RF sensor is too far for proper operation.

Figure 3 - Allowable Approach Direction

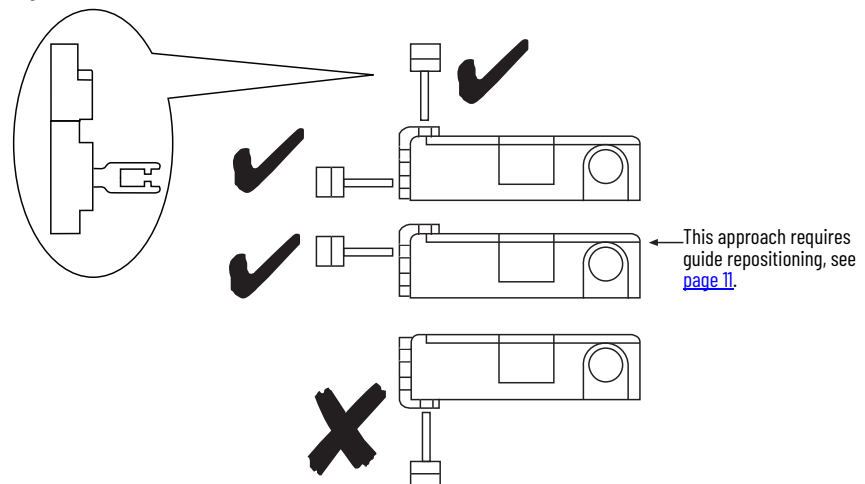

Minimum Operating Radius

Figure 4 shows the minimum operating distances along the length and perpendicular when applied to hinged doors.

Figure 4 - Minimum Operating Distance [mm (in.)]

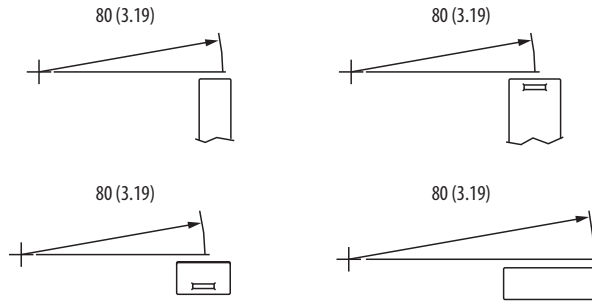
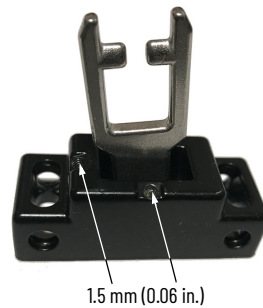

Figure 5 shows the location of the two 1.5 mm (0.06 in.) set screws that can be adjusted to preset the actuator to an optimal angle, if needed.

Figure 5 - Actuator Set Screw



Manual Release

The manual release feature only applies to TLSZR (Power to Release) switch. In some cases, you must manually release the locked actuator.

Figure 6 shows the two locations from which the actuator can be manually released.

1. Remove the T20 Torx screw.
2. To release the actuator, insert a small screwdriver or rod in the hole.

If power is applied to the switch when the actuator is released, the OSSD safety outputs turn off and the switch goes to a faulted state with the status indicator flashing red at 4 Hz. Power then must be cycled to the switch to return it to an operational state.

Figure 6 - Manual Release

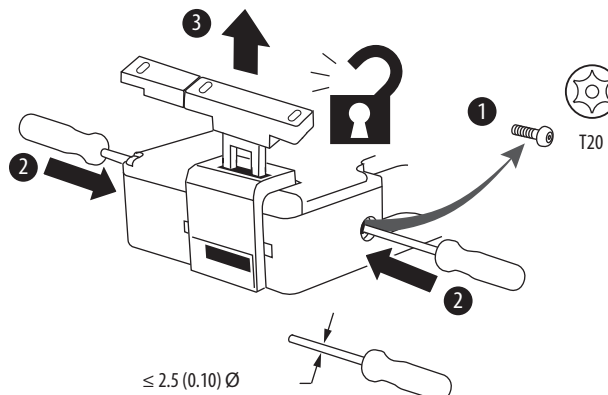

Manual Override Cover

[Figure 7](#) shows an optional cover that is available only for the TLSZR (Power to Release) switch. This cover has a lever that allows you to unlock the actuator manually at any time. Rotate the lever 90° to unlock the actuator.

If power is applied to the switch when the actuator is released, the OSSD safety outputs turn off, and the switch goes to a faulted state with the status indicator flashing red at 4 Hz. Power is then cycled to the switch to return it to an operational state.

Figure 7 - Manual Override Cover

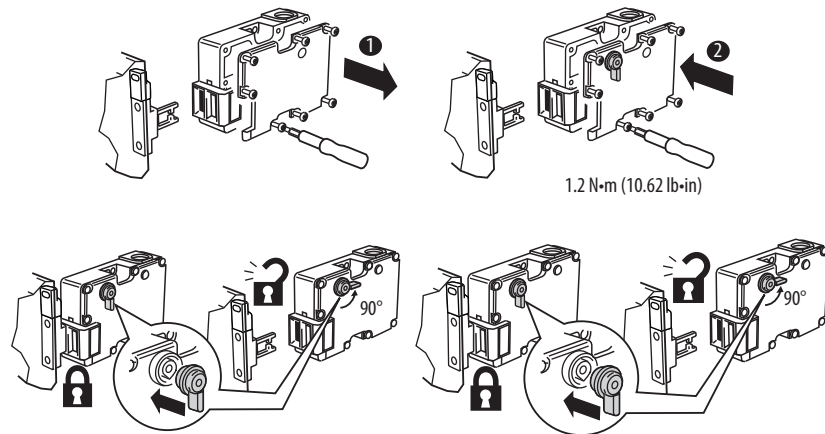

Pair Proximity

If a pair of TLSZ guard locking switches are mounted too close to each other, the two RF fields could interact causing crosstalk. Cross talk results in nuisance faults.

A minimum of 200 mm (8 in.) must be used to help achieve correct operation.

The restriction also applies if a TLSZ guard locking switch is mounted close to the 440G-LZ guard locking and the 440N-Z SensaGuard™ switches.

Guide Repositioning

The actuator guide can be repositioned to facilitate alignment of the actuator. In steps 8...11 ([Figure 8](#)), rotate the metal guide to allow the switch body to be fastened flush to the mounting surface.

Figure 8 - Guide Repositioning

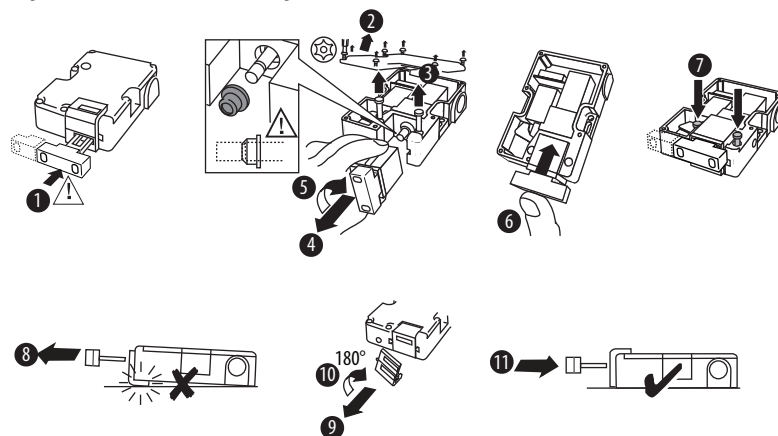

Steel Locking Bolts

The TLSZ guard locking switch is assembled in the factory with plastic pins that secure the actuator guide. The plastic pins are rated for a holding force of 1500 N (337 lb). The plastic pins must be replaced with the steel bolts to achieve a holding force of 2000 N (585 lb). [Figure 9](#) shows how to remove the cover to replace the blue plastic pins with steel bolts.

Figure 9 - Steel Bolt Installation

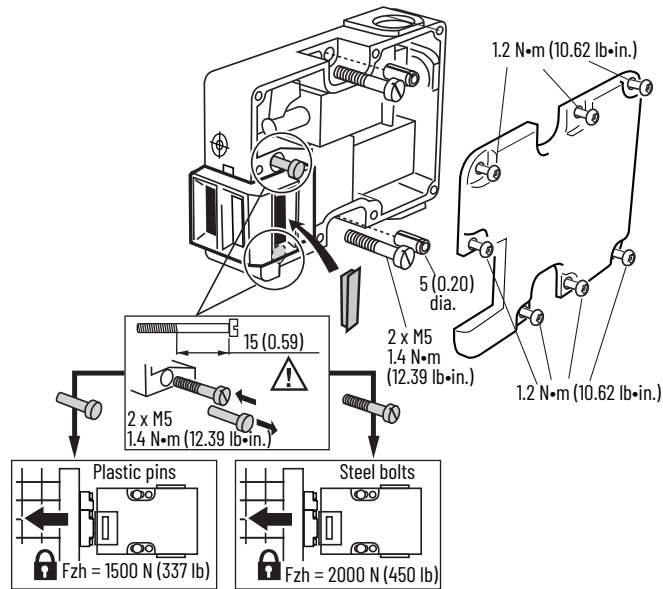

Actuator Clearance

[Figure 10](#) shows the clearance requirements for the TLSZ guard locking switch. The switch must not be used as a guard stop. You must provide a mechanical stop at least 1 mm (0.04 in.) away from the actuator guide. The actuator must be inserted within 4 mm (0.16 in.) or less from the actuator guide to be sure it locks.

Figure 10 - Clearance and Insertion Distance

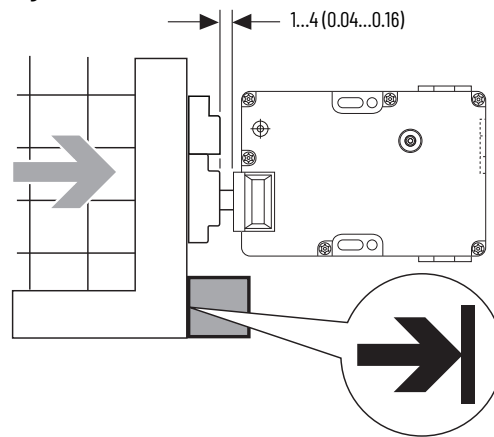

As shown in [Figure 11 on page 13](#), the TLSZ guard locking switch has two slotted holes to facilitate installation. The slots allow up to 8 mm (0.31 in.) of movement of the switch body to achieve the proper clearance with the actuator.

1. Use the slotted holes for initial installation.
2. After alignment with the actuator, secure the switch body in place by adding mounting hardware in the circular holes.

- To attain the maximum holding force, replace the plastic pins with steel screws inside the cover.

Figure 11 - Mounting Slots for Alignment [mm (in.)]

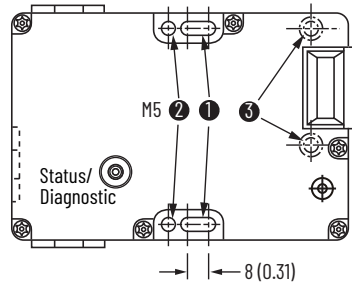

Approximate Dimensions

Figure 12 shows the approximate dimensions for the switch, target, and actuator.

Figure 12 - Approximate Dimensions [mm (in.)]

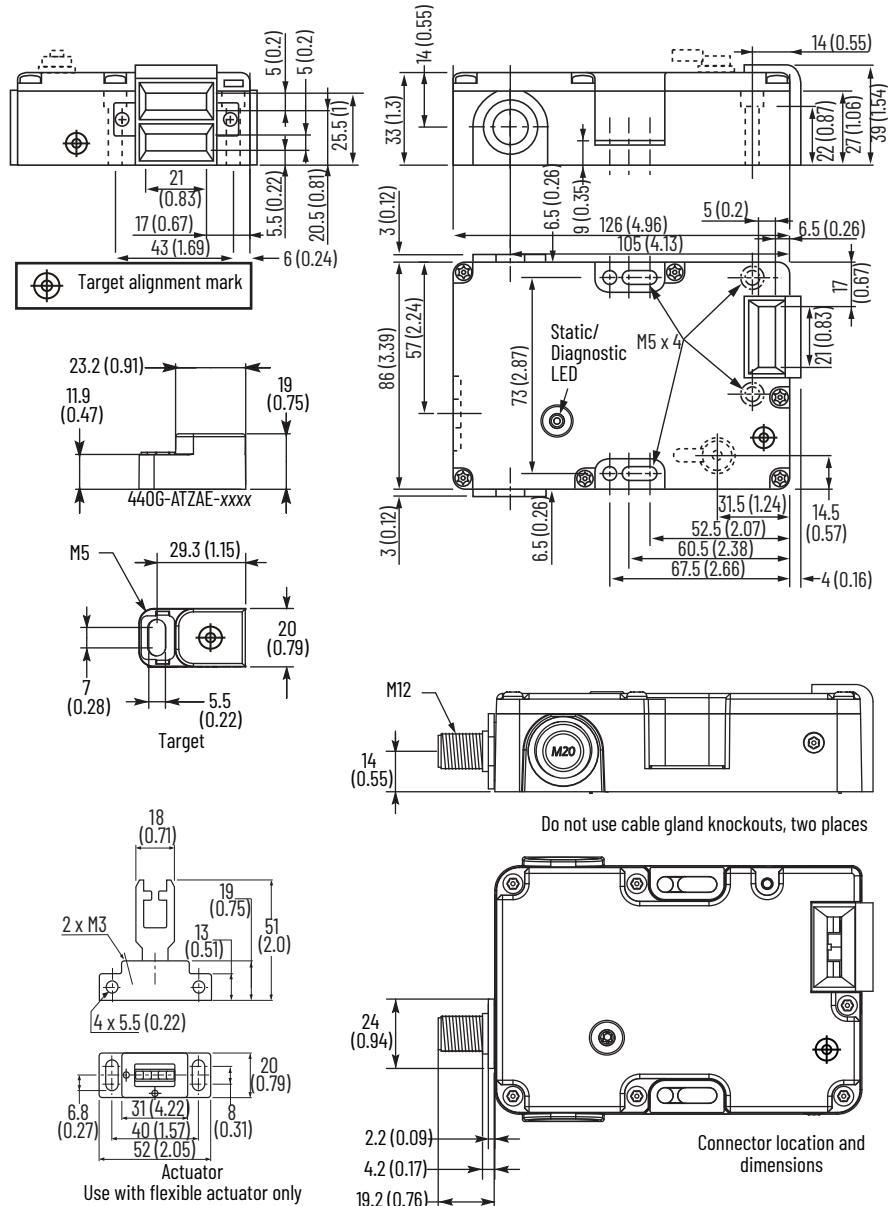
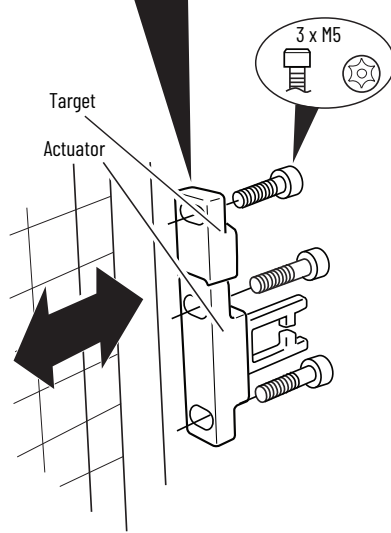
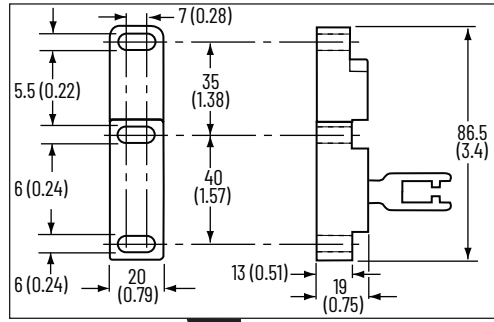

Figure 13 shows the dimensions for mounting the target that is next to the actuator.

Figure 13 - Actuator/Target Mounting Dimensions [mm (in.)]



Wiring

Connections

The TLSZ guard locking switch is only available with an 8-pin DC Micro M12 quick-disconnect connector. [Figure 14](#) and [Table 2](#) show the pin assignments and their functions and typical mating cordsets. Other cordsets are available at www.rockwellautomation.com/en-us/products/hardware/allen-bradley/connection-devices/cables-and-cordsets/dc-micro--m12-/dc-micro-cordsets-and-patchcords.html.

Figure 14 - 8-pin Micro Quick Disconnect Cables

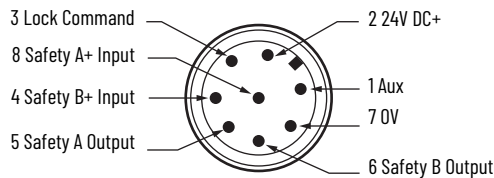

Table 2 - TLSZ Quick Disconnect Pin Assignments

| Typical Mating Cordsets | Color | Function | Pin |
|--|--------|--------------------------|-----|
| 889D-F8NB-x ⁽¹⁾ (Red, PVC) | White | Aux | 1 |
| | Brown | 24V DC Supply | 2 |
| | Green | Lock Command | 3 |
| | Yellow | Safety B+ Input | 4 |
| 889D-F8AB-x ⁽¹⁾ (Black, PVC) | Gray | Safety A Output (OSSD A) | 5 |
| | Pink | Safety B Output (OSSD B) | 6 |
| | Blue | Ground (0V) | 7 |
| | Red | Safety A+ Input | 8 |

(1) Replace symbol with 2 [2 m (6.56 ft)], 5 [5 m (16.4 ft)], 10 [10 m (32.8 ft)], 15 [15 m (49.2 ft)], 20 [20 m (65.62 ft)] or 30 [30 m (98.4 ft)] for standard cable lengths. The TLSZ guard locking switch is tested to operate with up to 120 m (393.7 ft) of the mating cables.

OSSD Inputs

The OSSD inputs are Safety A+ and Safety B+. These inputs can be pure 24V DC, or they can contain test pulses. The OSSD inputs allow the TLSZ guard locking switches to be connected in-series while maintaining a high level of safety performance.

OSSD Outputs

The OSSD outputs are Safety A and Safety B. These outputs are 24V signals that contain test pulses. The test pulses are used to detect short circuits to 24V, to 0V and cross faults (from Safety A to Safety B). This description of the test pulses is provided for informational purposes; you cannot modify them.

[Figure 15 on page 16](#) shows the safety output test pulses when connected to a 1K resistive load for hardware (HW) revisions A and B, and for firmware (FW) revisions A through C. The pulses are 25 μ s wide and repeat every 20 ms. The exact shape of the pulses depends on the nature of the load. The capacitive and resistive effects of the load are determined with the combination of cabling, cable routing, and connected devices.

Figure 15 - Output Test Pulses

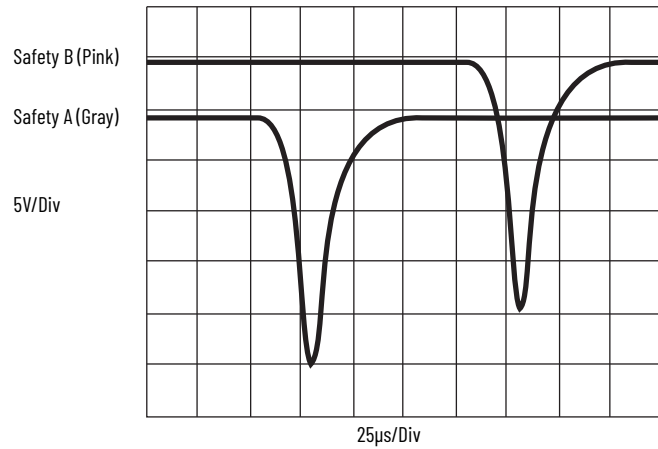

Auxiliary Output

Table 3 shows the auxiliary output functions. The auxiliary output is a 24V DC logic signal, whose function is dependent on the catalog number selected. The auxiliary signal responds independently of the OSSD safety outputs. The auxiliary output is not a safety-rated signal and must only be used to indicate the status of the switch.

Table 3 - Auxiliary Output Function

| Cat. No. | Function | Value |
|--|-----------------|--|
| 440G-TZS2IU ^{PR} H 440G-TZS2IU ^{PL} H | Lock Status | 24V when actuator is unlocked 0V when actuator is locked |
| 440G-TZS2IU ^{TR} H 440G-TZS2IU ^{TL} H | Actuator Status | 24V when actuator inserted (gate closed) 0V when actuator removed (gate open) |

Lock Command

Table 4 shows the lock command function. The lock command is a 24V logic signal, with a current of less than 5 mA. The function of the logic signal is dependent on the catalog number. The 24V power supply connection provides the power to operate the locking solenoid.

Table 4 - Lock Command Function

| Cat. No. | Switch Type | Function |
|--|------------------|---|
| 440G-TZS2IU ^{PR} H 440G-TZS2IU ^{TR} H | Power to Release | 24V unlocks the actuator 0V locks the actuator |
| 440G-TZS2IU ^{PL} H 440G-TZS2IU ^{TL} H | Power to Lock | 24V locks the actuator 0V unlocks the actuator |

Commissioning

Before use, the guard locking switch must first learn a new RFID target. This step is not done at the factory.

The guard locking switch can learn up to eight targets consecutively. Use this process if there is a potential for the target to become damaged, inoperable, or lost. When a new target is learned, the guard locking switch no longer recognizes the old target.

Preparation

Wire the guard locking switch with at minimum the functionality shown in [Figure 16](#).

- Power — connect the brown wire to +24V.
- Gnd — connect the blue wire to 0V.
- Lock — Leave the green wire open when learning the first target. Connect the green wire to 24V to teach a TLSZR guard locking switch subsequent targets. The TLSZL guard locking switch ignores the Lock command during learning.
- Safety A+ and Safety B+ — connect red and yellow wires to 24V during commissioning. If 24V is not applied to the A+ and B+ inputs, then the indicator flashes green after commissioning if the guard locking switch is locked.
- Safety A and Safety B — optional, no connection required for commissioning.
- Aux — optional, no connection required for commissioning.

Figure 16 - Commissioning Wiring

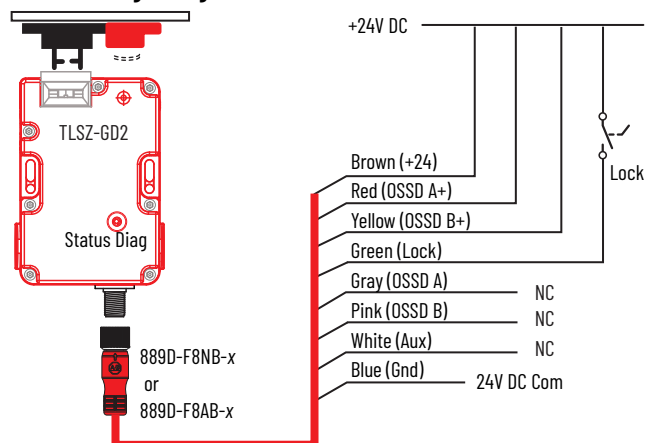

First Time Power-up

Turn on the 24V DC power without the actuator and target.

The Status/Diagnostic indicator blinks green three times, pauses 2 seconds, and then blinks green eight times. Eight is the number of times a new target can be learned. The guard locking switch continuously repeats the two-second pause followed by the eight blink sequence.

Learn First Target

[Table 5](#) shows the events that take place when the first target is learned. The lock command is ignored until after the guard locking switch learns its first target, therefore, the lock command can be 24V or 0V during the first-time learning sequence.

Table 5 - First Target Learning Events

| Step | Event | Indicator Color | Blink Rate | Duration |
|------|--|-----------------|-------------|------------|
| 1 | Apply power to guard locking switch | Red | Solid | – |
| 2 | Present actuator/target | Red | Solid | – |
| 3 | Detect target | Red | Solid | 2...25 s |
| 4 | Verifying target | Green/Red | 1 Hz | 15 s |
| 5 | Report commissioning error (see Table 7 on page 19) or continue | – | – | – |
| 6 | Programming switch | Green/Red | 4 Hz | 15 s |
| 7 | Finalizing | Red | Solid | 2 s |
| 8 | Number of learns remaining | Green | # of learns | 15 s |
| 9 | Learn completed | | | |
| | PTR | Green | Solid | Continuous |
| | PTL | Red | | |

Learn Additional Targets

[Table 6](#) shows the steps that take place when teaching the guard locking switch to recognize an additional target. For PTR switches, the lock command must connect to +24V to learn additional targets. The PTL switch ignores the lock command during learning.

Table 6 - Additional Target Learning Steps

| Step | Event | Indicator Color | Blink Rate | Duration |
|------|--|-----------------|-------------|------------|
| 1 | Apply power to guard locking switch PTR: Apply 24V to lock command PTL: Ignores lock command | Red | Solid | – |
| 2 | Present new actuator/target | Red | Solid | – |
| 4 | Detect target | Red | Solid | 3...25 s |
| 5 | PTR: Solenoid automatically locks PTL: No action | Red | Solid | 0.5 s |
| 6 | Verifying target | Green/Red | 1 Hz | 15 s |
| 7 | Report commissioning error (see Table 7 on page 19) or continue | – | – | – |
| 8 | Programming switch | Green/Red | 4 Hz | 15 s |
| 9 | Finalizing | Red | Solid | 2 s |
| 10 | Number of learns remaining | Green | # of learns | 15 s |
| 11 | PTR: Solenoid unlocks then locks PTL: no action | – | – | 0.5 s |
| 12 | Learn completed | | | |
| | PTR | Red | 4 Hz | Continuous |
| | PTL | Red | Solid | |
| 13 | PTR: Cycle power PTL: Ready for use | – | – | – |

Commissioning Errors

During commissioning, the guard locking switch performs certain checks. If an error is detected, the Status/Diagnostic indicator reports the error. [Table 7](#) lists the commissioning error codes. The error code is generated after the guard locking switch verifies the target. If an error code is generated, the guard locking switch must be power cycled before further learning is started.

Table 7 - Commissioning Error Codes

| Indicator Flashes (4 Hz) | Code |
|-------------------------------------|--|
| Red-Red-Red-Green-Green | Target already learned |
| Red-Red-Red-Green-Green-Green | Bad RFID Target that is removed while programming PTL |
| Red-Red-Red-Green-Green-Green-Green | Exceeded learning eight targets |

Power-up Self-check

Upon power-up, the TLSZ guard locking switch performs an internal self-check, which takes approximately 3 seconds. Whether the actuator/target is inserted and the lock command is present; the indicator remains red or turns green after the self-check. [Table 8](#) shows the indicator sequence during self-check with the actuator/target inserted. The self-check sequence occurs only once.

Table 8 - Self-check Indicator Sequence

| Model | Lock Signal | Indicator Sequence | OSSD Outputs |
|-------|-------------|-----------------------------|--------------|
| TLSZR | OFF | Green-Green-Green-Red-Green | ON |
| | ON | Green-Green-Green-Red | OFF |
| TLSZL | OFF | Green-Green-Green-Red | OFF |
| | ON | Green-Green-Green-Red-Green | ON |

Notes:

Functional Testing

A manual functional electric test must be done:

- After installation
- After any maintenance or change of component
- If the guard is used infrequently
 - Less than once per month for SIL 3/PLe
 - Less than once per year for SIL 2/PLd

Testing Procedure



ATTENTION: During the functional test, confirm that there are no persons in the danger area and that the machine startup causes no hazard.

1. Confirm that the guard door is open.
2. Connect the 24V DC power to pin 2 and ground (0V) to pin 7. The guard locking switch conducts a self-testing routine at the end of which the diagnostic indicator shows steady red.
3. Test to confirm that the machine cannot start.
4. Confirm the lock command at pin 3 is set to 0V for PTR and 24V for PTL types.
5. Test again to confirm that the machine cannot start.
6. Close the guard door and then confirm that the guard is mechanically locked and the diagnostic indicator shows steady green.
7. Test to confirm that the machine can now start.
8. Change the lock command at pin 3. Set it to 24V for PTR and 0V for PTL types.
9. Confirm the machine stops, the guard door is mechanically unlocked, and the machine cannot restart.

Notes:

Application and Wiring Examples

The following application and wiring examples are intended to show how the TLSZ products can be applied. Variations to the following examples may be required to meet your specific requirements.

Wiring to GLP Relay

The GLP safety relay is designed to operate with PTR guard locking switches. To use a PTL guard locking switch, you must use an interposing relay on the lock command at GLP terminal 51. In the example shown in [Figure 17](#), the GLP safety relay allows the gate to unlock when the motor is running at a Safely-limited Speed.

Figure 17 - GLP and TLSZR Schematic

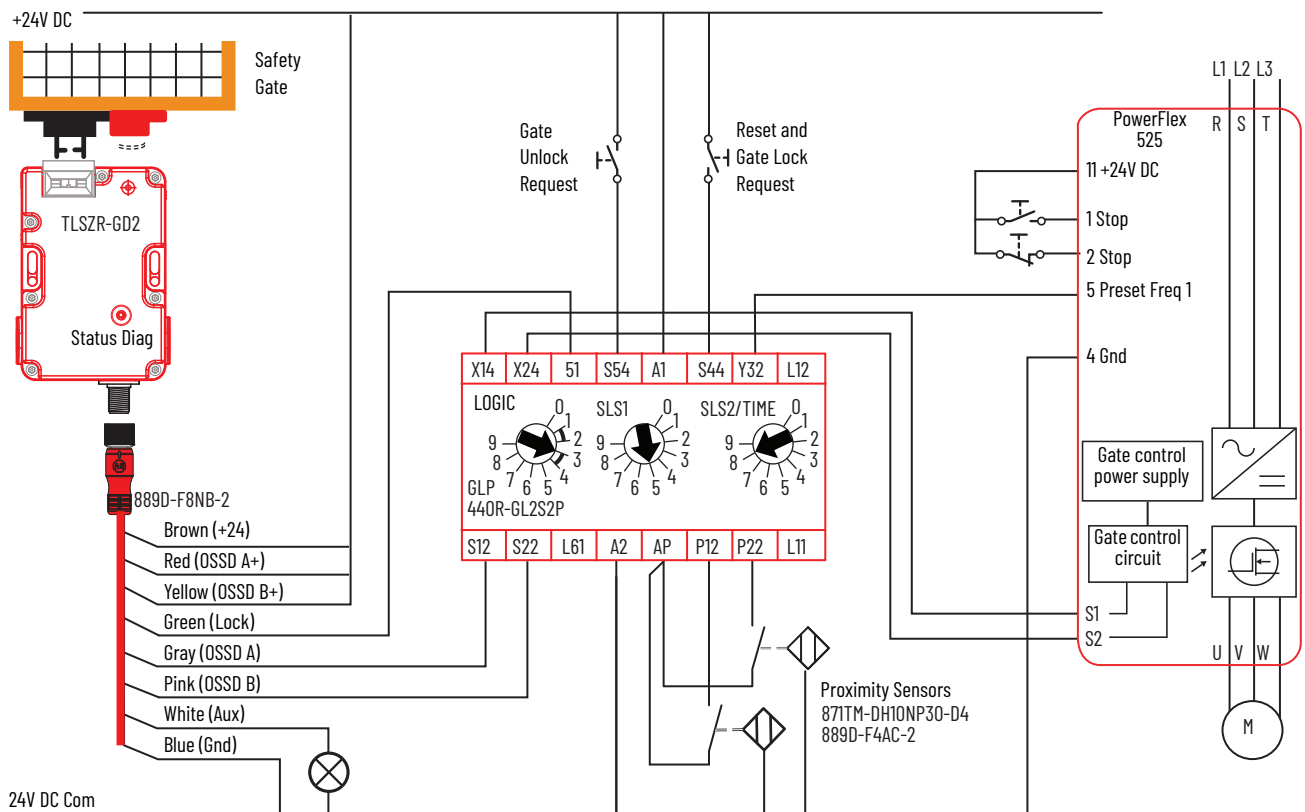

Circuit Status as Shown

The gate is open and unlocked. The motor is off. The GLP is ready for reset. The GLP safety relay has a Logic setting of 3: (Safely-limited Speed with Logic IN OFF), a Safely-limited Speed (SLS1) setting of 5 (5 Hz) and a maximum (SLS2) speed setting of 8 (2000 Hz). The safety outputs (X14 and X24), the single wire safety output (L11), and the auxiliary output (Y32) are off.

IMPORTANT Start the GLP logic configuration from 0 to configure X14 and X24 for use as safety outputs.

Starting

Close the gate and press Reset to lock the gate and turn on the GLP safety outputs. Press Start to turn on the motor.

Safely-limited Speed

A normal production stop is performed by pressing Stop. Access through the safety gate is initiated by pressing Gate Unlock Request. The Y32 output of the GLP safety relay turns on and commands the PowerFlex® drive to bring the motor to a safe slow speed (Preset Freq 1). When the proximity sensors detect the speed has dropped below the Safely-limited Speed (5 Hz), the gate becomes unlocked. The operator can enter the machine cell, as the motor continues to run at the safe slow speed. After you leave the cell and close the gate, press Reset to lock the gate and return the machine to production speeds.

The circuit meets the safety requirements up to Category 3, Performance Level d in accordance with ISO 13849-1 and SIL CL 2 in accordance with IEC 62061.

Wiring to GLT Relay

The GLT safety relay is designed to operate with PTR guard locking switches. To use a PTL guard locking switch, you must use an interposing relay on the lock command at terminal 51 of the GLP safety relay.

In this example shown in [Figure 18 on page 25](#), the GLT safety relay sends an immediate command to the drive to turn off. After 8 seconds, the GLT safety relay turns off its safety outputs and unlocks the gate. The risk assessment must determine the adequate time delay for the machine to achieve a safe state before unlocking the gate.

Figure 18 - GLT and TLSZR Schematic

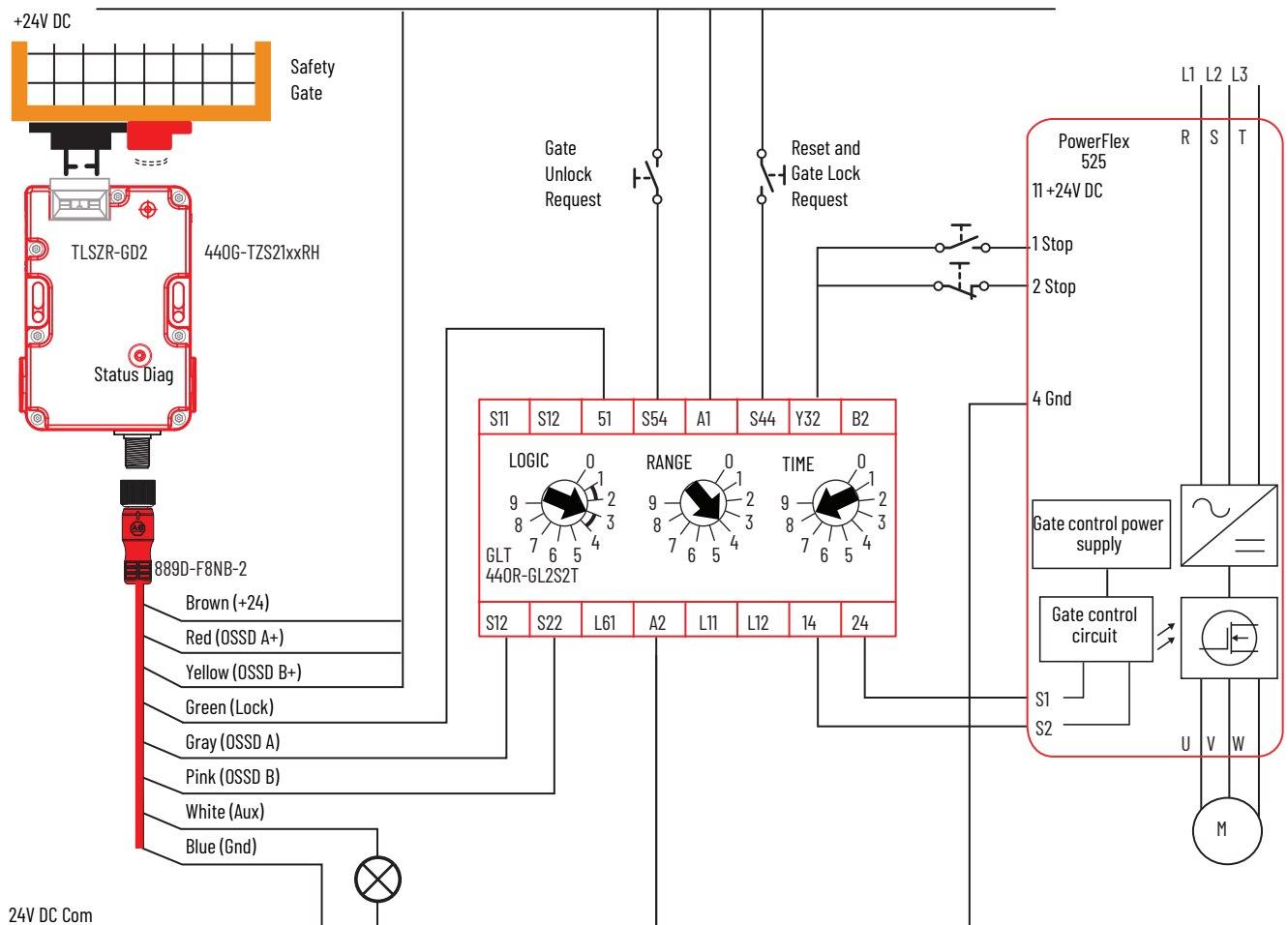

Circuit Status as Shown

The gate is open and unlocked. The motor is off. The GLT safety relay is ready for reset. The GLT safety relay has a Logic setting of 3: (Category 1 Stop), a Range setting of 4 (10 seconds) and a Time setting of 8 (80%). The Y32 output turns off immediately; 8 seconds later, the safety outputs turn off.

The safety outputs (14 and 24) and the single wire safety output (L11) are off and the auxiliary output (Y32) is on.

IMPORTANT Start the GLT logic configuration from 0 to configure 14 and 24 for use with pulse testing; the PF525 can operate with pulse tested inputs to S1 and S2.

Starting

Close the gate. Press Reset and Gate Lock Request to lock the gate and turn on the GLT safety outputs. Press Start to turn on the motor.

Stopping

Normal production stops are performed by pressing Stop. Access through the safety gate is initiated by pressing the Gate Unlock Request. The Y32 output of the GLP safety relay turns off, which commands the PowerFlex drive to bring the motor to a stop. After the configured time delay (8 seconds) expires, the

GLT safety outputs turn off, and the gate becomes unlocked. After you leave the cell and close the gate, press Reset to lock the gate and return the machine to a production state.

The circuit meets the safety requirements up to Category 3, Performance Level d in accordance with ISO 13849-1 and SIL CL 2 in accordance with IEC 62061.

Wiring to DI and EMD Relay

The TLZ can be connected to the DI and EMD safety relays. The DI safety relay monitors the safety outputs of the TLZR guard locking switch and the EMD safety relay enables the gate to be unlocked after a configured delay time expires.

B1 is connected to B2 to allow for retriggering. If you open and close the E-stop and press Reset before the delay expires, the EMD timer resets.

Upon initial power-up, the TLSZ guard locking switch must be cycled for the DI safety relay to recognize the TLSZ OSSD signals.

In the example shown in [Figure 19](#), an E-stop initiates the machine shutdown. After an eight-second delay, the TLZR guard locking switch is allowed to be unlocked and the hazards that remain are turned off. A selector switch is required to maintain the gate in an unlock state. The risk assessment must determine the adequate time delay for the machine to achieve a safe state before unlocking the gate.

Figure 19 - DI with EMD and TLSZR Schematic

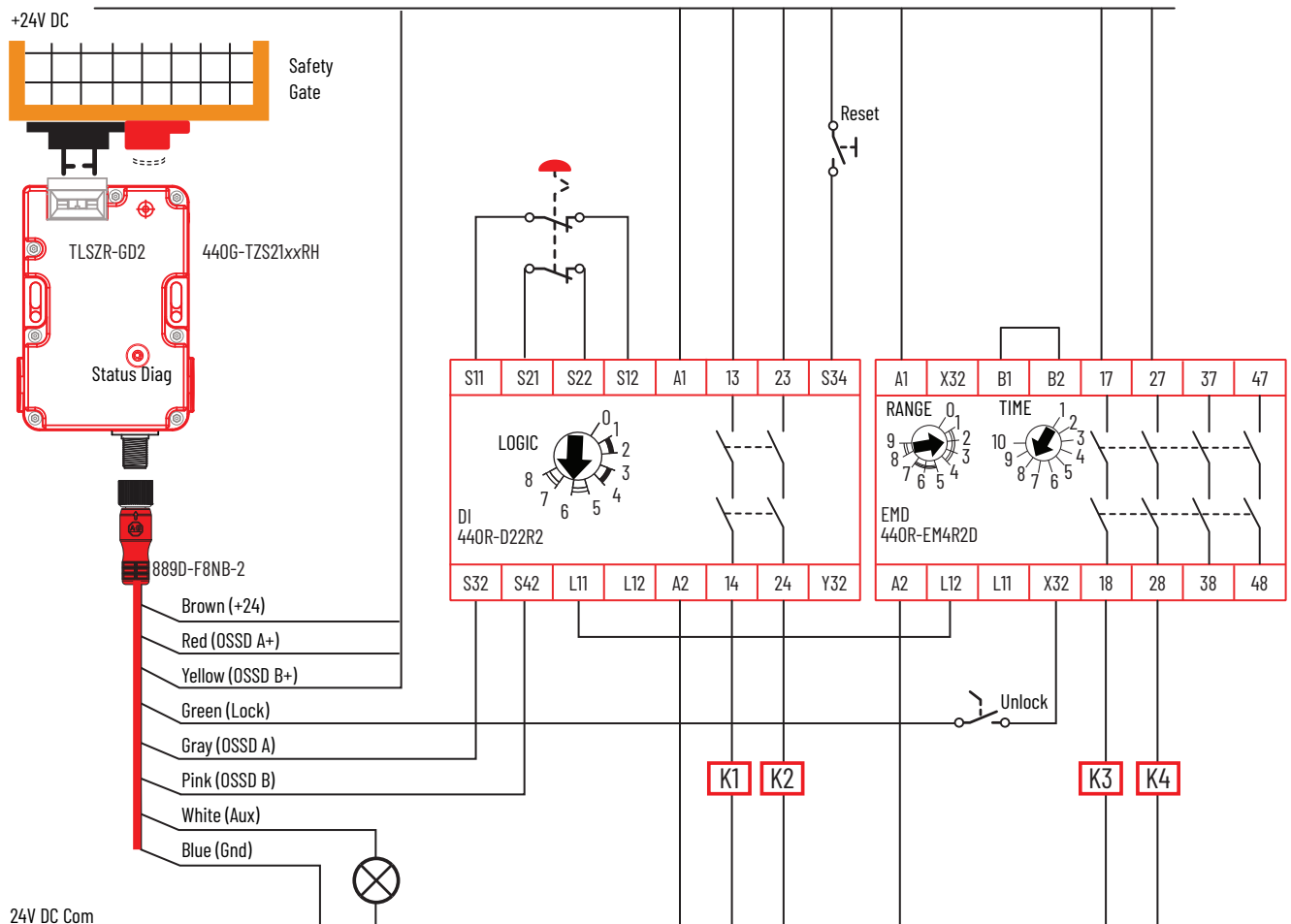

Circuit Status as Shown

The E-stop is released. The gate is open and unlocked. K1, K2, K3, and K4 are off. The DI safety relay is configured for two inputs with monitored manual reset. The EMD safety relay is configured for 8-second off-delay; Range setting of 2 is 10 s, Time setting of 8 is 80% of the range. The X32 terminal is on because the EMD safety outputs are off.

Starting

With the Unlock switch open, close the gate. Press Reset to lock the gate and turn on the K1...K4 safety contactors.

Stopping

Stopping is initiated by pressing the E-stop. K1 and K2 contactors turn off immediately. The single wire safety signal from the DI (L11) to the EMD (L12) also turns off immediately, and the EMD safety relay starts the off-delay timer. After 8 seconds, contactors K3 and K4 turn off and X32 goes to 24V. The unlock switch is enabled, and the gate can be unlocked. While the gate is unlocked, the DI safety relay cannot turn the safety outputs back on. After you leave the cell and close the gate, open the unlock switch to lock the gate, and release the E-stop.

The circuit can meet the safety requirements up to Category 4, Performance Level e in accordance with ISO 13849-1 and SIL CL 3 in accordance with IEC 62061.

Wiring to DG Relay

The TLSZR guard locking switch can be used in GuardLink® applications; the TLSZL guard locking switch cannot be used in GuardLink applications. The GuardLink system uses taps to connect a series of devices to one relay. The GuardLink system provides control and status information between the machine control system and the safety system.

[Figure 20 on page 28](#) shows four TLSZR guard locking switches that are connected on two GuardLink circuits from one DG safety relay. The DG safety relay can accommodate up to 32 devices on each input. The devices can be a mix of many different safety devices. When guard locking devices are included in the GuardLink system, the lock/unlock command must come from the machine control system through the 44OR-ENETR module.

See publication [44OR-UM015](#) for further details.

Figure 20 - DG with TLSZR Schematic

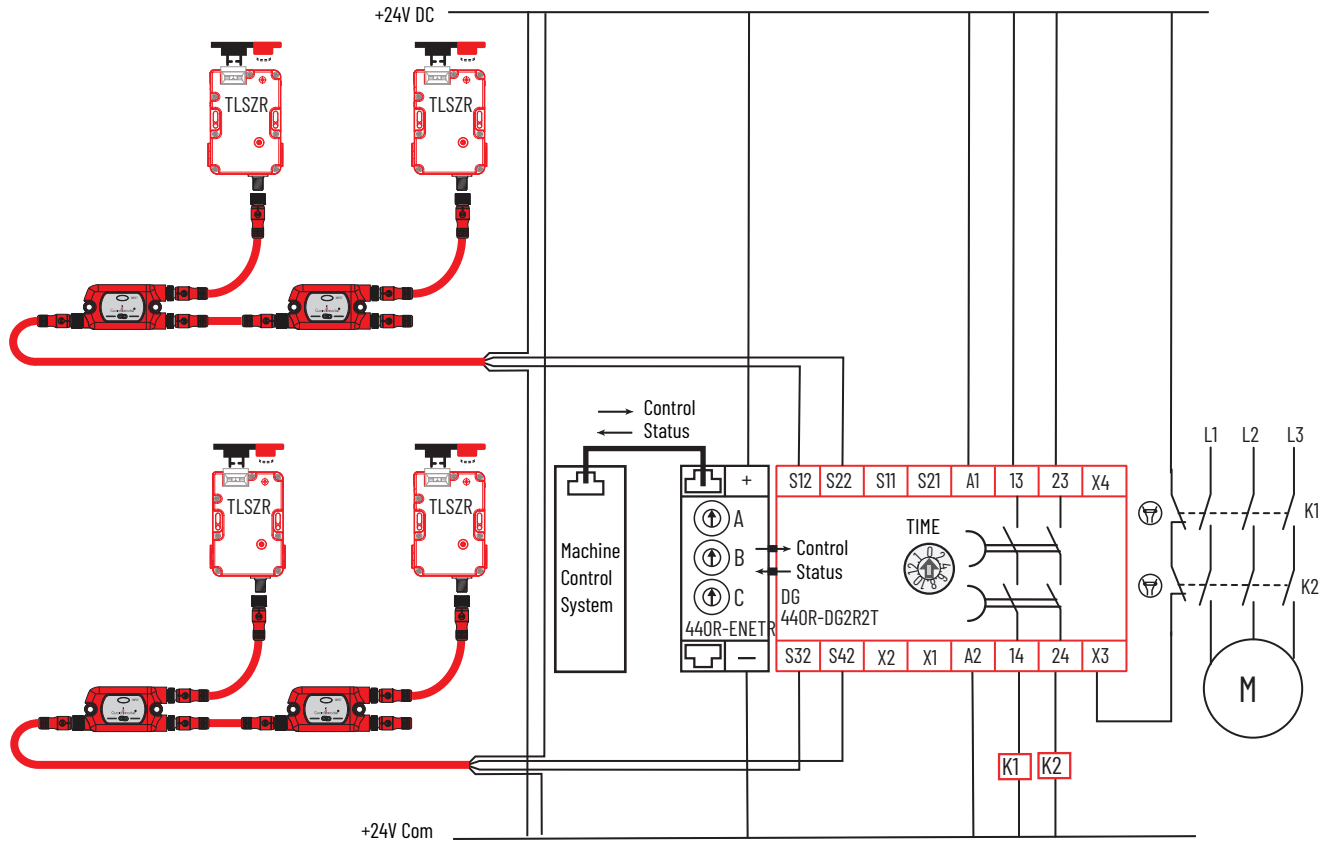

Wiring to CR30 Software Configurable Safety Relay

The CR30 is a software configurable relay that can easily interface with the TLSZ guard locking switch. Version 10 and later of Connected Components Workbench™ software has a locking function that is useful for guard locking applications.

[Figure 21 on page 29](#) shows an example schematic. The CR30 safety relay monitors the motor running signal from the PowerFlex® 525. When the motor is not running, the safety gate can be unlocked, and the PowerFlex 525 goes to a Safe Torque Off state.

Figure 21 - CR30 Schematic

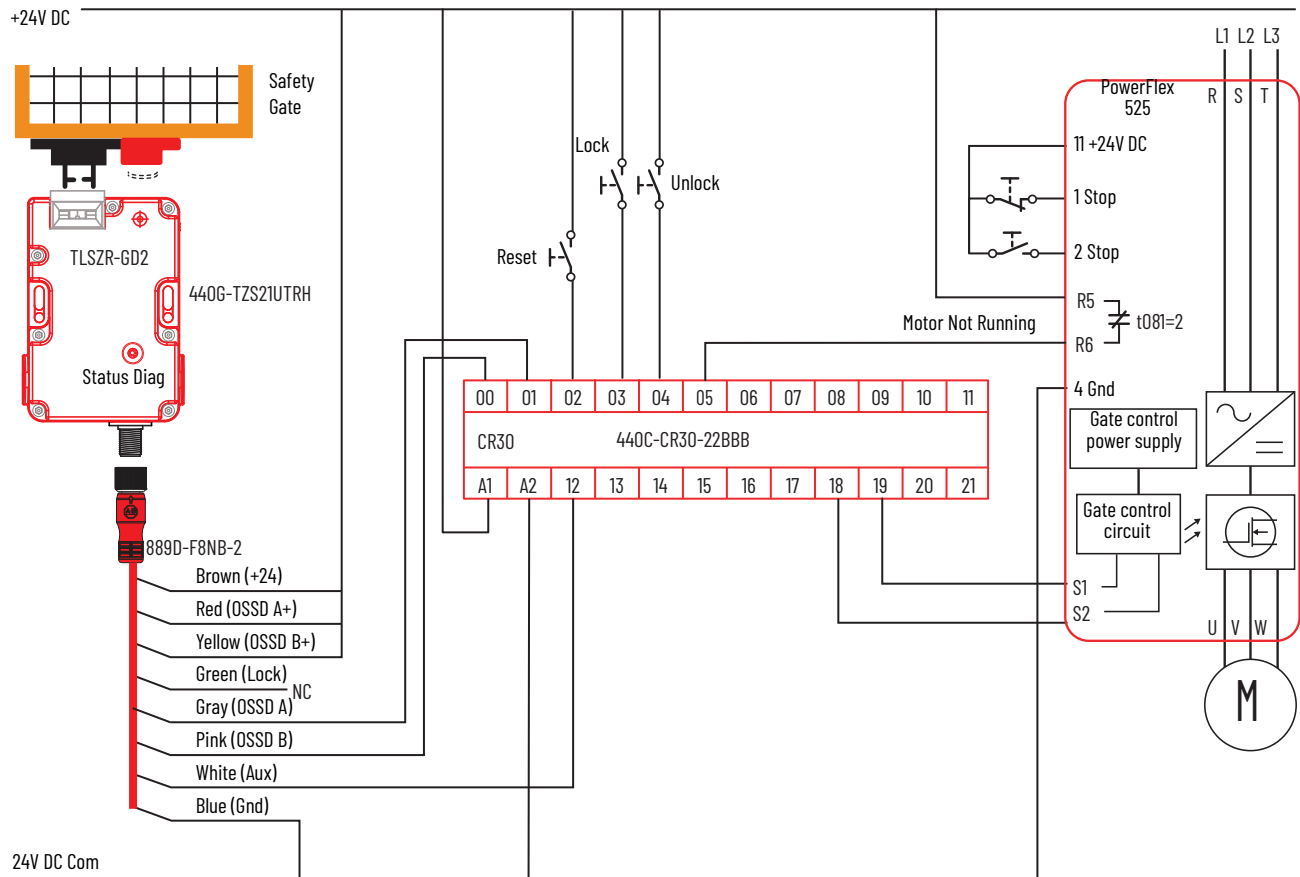
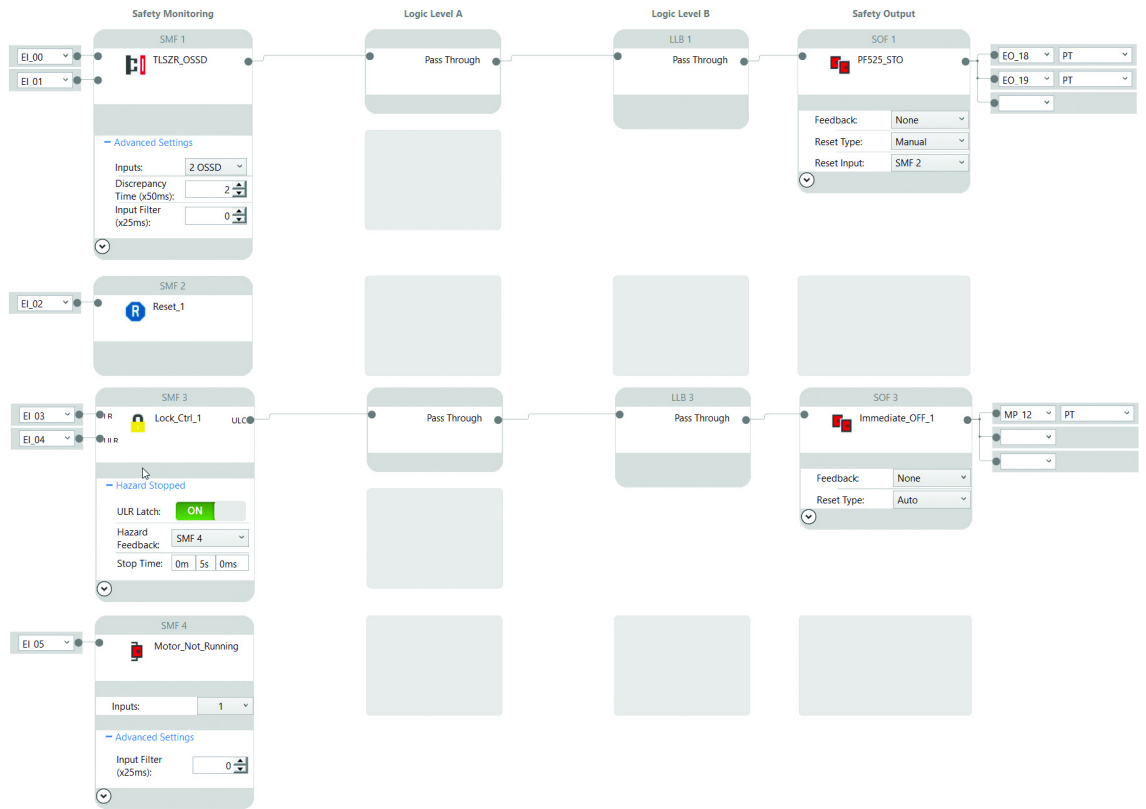

Figure 22 on page 30 shows an example CR30 safety relay configuration that works with the schematic in Figure 21.

The TLSZR OSSD outputs drive the Safe Torque Off (STO) signals of the PowerFlex 525 drive. The STO is enabled after the gate is locked and the Reset is pressed. The PowerFlex 525 STO inputs can tolerate the pulse test that is generated by the CR30 outputs.

The Lock_Ctrl_1 block controls the unlock command to the TLSZR guard locking switch. The unlock Stop Time delay is set to 5 seconds, and the ULR Latch (Unlock Request) is set to on. When an unlock request is made, the command is issued 5 seconds after the motor stops running, and the unlock request is latched on.

Figure 22 - CR30 Configuration in Connected Components Workbench



Wiring to 1734 POINT Guard I/O

The TLSZ can be connected to a 1734 POINT Guard I/O™. The catalog number 889D-F8NB cordset has 24-AWG wires; which allows three wires that are connected to one terminal. This wiring example shows a Power to Lock switch with a Door Status auxiliary signal. The PLC logic checks to see if the door is closed before issuing a lock command. The schematic for this example is shown in [Figure 23](#).

Figure 23 - 1734 and TLSZL Schematic

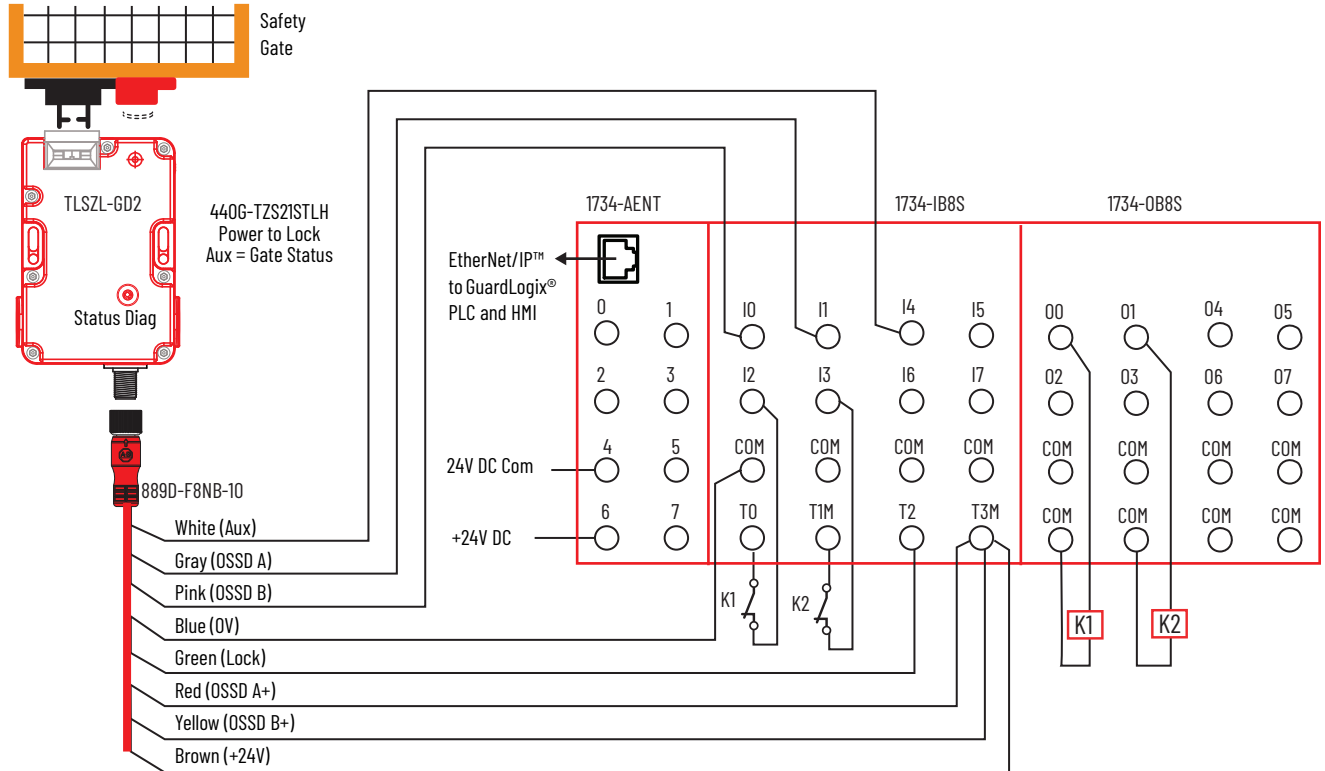

[Figure 24](#) shows the General Tab of the 1734-IB8S Module Properties. The Input Status must be set to Combined Status – Muting as this setting is used by the Dual Channel Input Stop logic block to verify that 1734-IB8S is operational. The Output Data must be set to Test, as the test outputs are used to generate test pulses for the output contactors.

Figure 24 - 1734-IB8S Module Properties - General

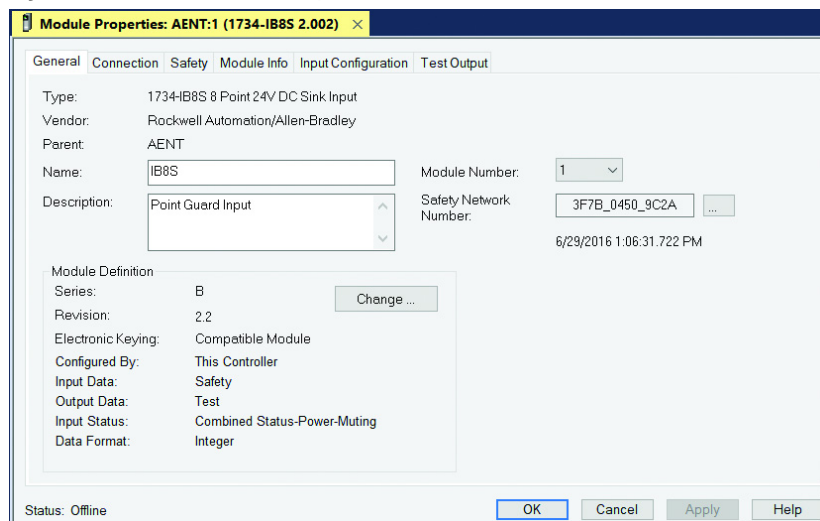

[Figure 25](#) shows the Input Configuration tab of the 1734-IB8S Module Properties. In this example, Points 0 and 1 monitor the OSSD outputs of the

TLSZL. The Type is set to Single (to allow the Logix program to detect potential faults) and the Mode must be set to Safety. Points 2 and 3 monitor the status of the output contactors K1 and K2. Set the Type to Single (to allow the program to detect potential faults). Safety pulse testing detects potential faults in the monitoring circuit. The TLSZ can operate with the Input Delay Time set to zero.

Figure 25 - 1734-IB8S Module Properties - Input Configuration

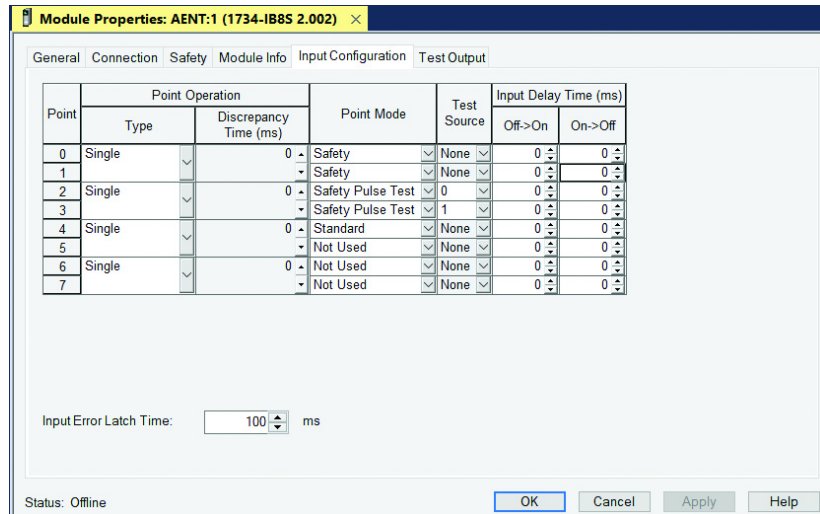
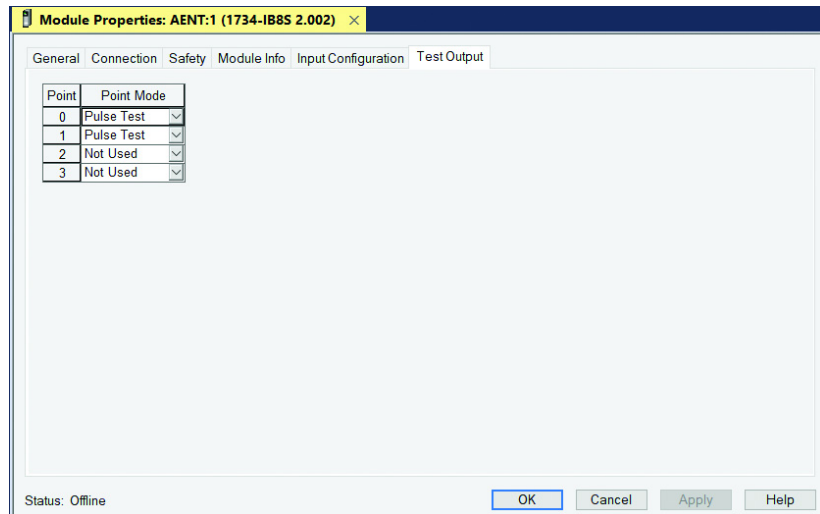

Figure 26 shows the Test Output tab of the 1734-IB8S Module Properties. In this example, Points 0 and 1 are set to pulse test as these points help check the integrity of contactors K1 and K2. Points 2 and 3 are set to Standard. Point 2 is the lock command, and Point 3 applies power to the TLSZL and supplies power to the OSSD inputs. By setting it to standard, you can programmatically turn Points 2 and 3 off and on.

Figure 26 - 1734-IB8S Module Properties - Test Output



[Figure 27](#) shows the General Tab of the 1734-OB8S Module Properties. The Output Data must be set to Safety, as it is controlling the output safety contactors.

Figure 27 - 1734-OB8S Module Properties - General

Module Properties: AENT:2 (1734-OB8S 2.002) x

General | Connection | Safety | Module Info | Output Configuration

Type: 1734-OB8S 8 Point 24V DC Source Output
 Vendor: Rockwell Automation/Allen-Bradley
 Parent: AENT
 Name: OB8S
 Description: PointGuard Output
 Module Number: 2
 Safety Network Number: 3F7B_0450_9C2A
 6/29/2016 1:06:31.722 PM

Module Definition
 Series: B
 Revision: 2.2
 Electronic Keying: Compatible Module
 Configured By: This Controller
 Input Data: None
 Output Data: Safety
 Input Status: Pt. Status
 Data Format: Integer

Status: Offline

OK Cancel Apply Help

[Figure 28](#) shows the Output Configuration tab of the 1734-OB8S Module Properties. Points 0 and 1 drive the output contactors K1 and K2. The point Types are set to Dual, and the Modes are set to Safety.

Figure 28 - 1734-OB8S Module Properties - Output Configuration

Module Properties: AENT:2 (1734-OB8S 2.002) x

General | Connection | Safety | Module Info | Output Configuration

| Point | Point Operation Type | Point Mode |
|-------|----------------------|------------|
| 0 | Dual | Safety |
| 1 | | Safety |
| 2 | Dual | Not Used |
| 3 | | Not Used |
| 4 | Dual | Not Used |
| 5 | | Not Used |
| 6 | Dual | Not Used |
| 7 | | Not Used |

Output Error Latch Time: 1000 ms

Status: Offline

OK Cancel Apply Help

[Figure 29 on page 34](#) shows an example logic program. A Dual Channel Input Stop function block monitors the TLSZL and a Configurable Redundant Output function block controls two contactors. This example can be used as a starting point for implementation; you must incorporate additional logic that is based on the risk assessment for the machine.

Figure 29 - Studio 5000® Example Logic Program



Wiring to 1732 ArmorBlock

The TLSZ guard locking switch can be connected to a 1732ES or 1732DS ArmorBlock® module by using a catalog number 871A-TS5-DM1 field attachable connector. The catalog number 889D-F8NB cordset has 24-AWG wires that connect to one pin. An example schematic is shown in [Figure 30](#).

You can also use an 871A-TS8-D1 field attachable connector at the TLSZ guard locking switch and a 5-wire cordset (catalog number 889D-M5NC-x).

Figure 30 - ArmorBlock Schematic

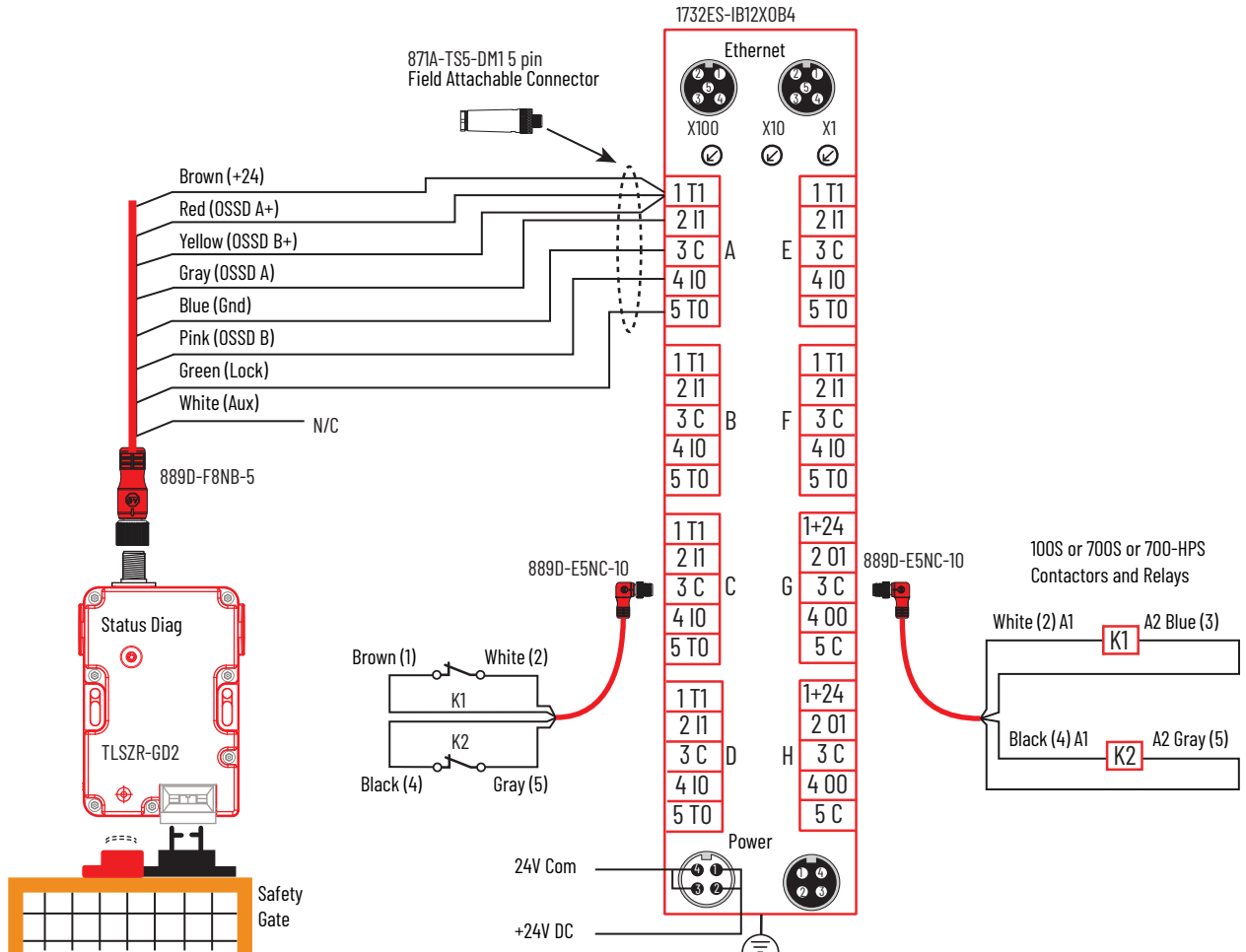

[Figure 31 on page 36](#) shows the General Tab of the ArmorBlock Module Properties. The Input Status must be set to Combined Status — Muting and the Output Data must be set to Combined.

Figure 31 - Module Properties - General

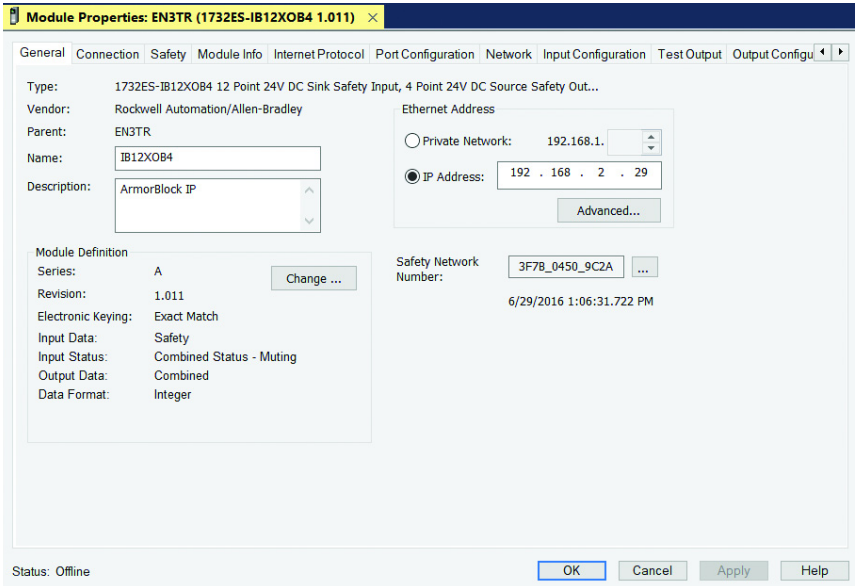

Figure 32 shows the Input Configuration tab of the ArmorBlock Module Properties. In this example, Points 0 and 1 monitor the OSSD outputs of the TLSZR guard locking switch. The Type is set to Single (to allow the Logix program to detect potential faults), and the Mode must be set to Safety. Points 4 and 5 monitor the status of the output contactors K1 and K2. Set the Type to Single to allow the Logix program to detect potential faults. The safety pulse test is used to detect potential faults in the monitoring circuit.

Figure 32 - Module Properties - Input Configuration

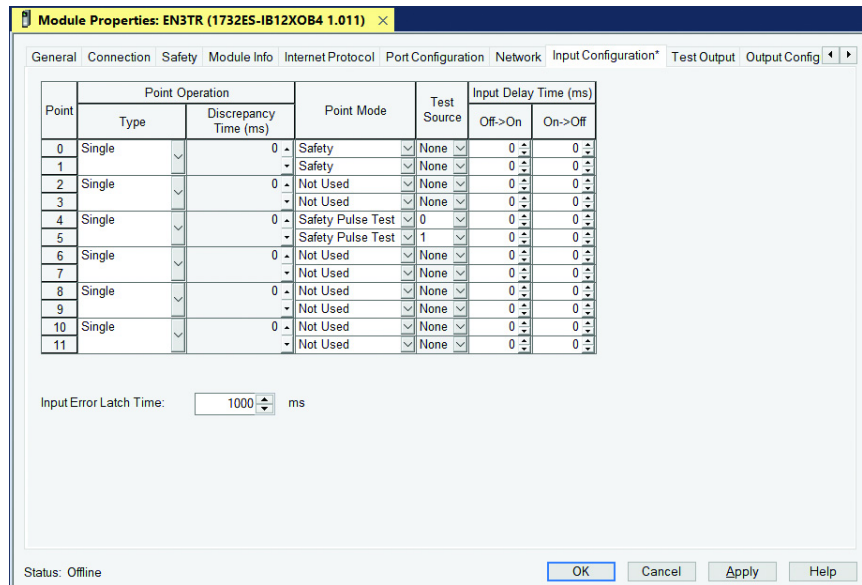

Figure 33 shows the Test Output tab of the ArmorBlock Module Properties. In this example, Points 0 and 1 are set to Standard. The Standard setting allows the program to control these two points. Point 0 applies power to the TLSZR guard locking switch. By setting it to Standard, you can programmatically turn this point off and on if the TLSZ guard locking switch has a fault condition. Point 1 is the lock/unlock command. In this example, the TLSZ is a PTR type, so 24V unlocks the switch. Use Points 4 and 5 to monitor the contactor outputs and are set to pulse test.

Figure 33 - Module Properties - Test Output

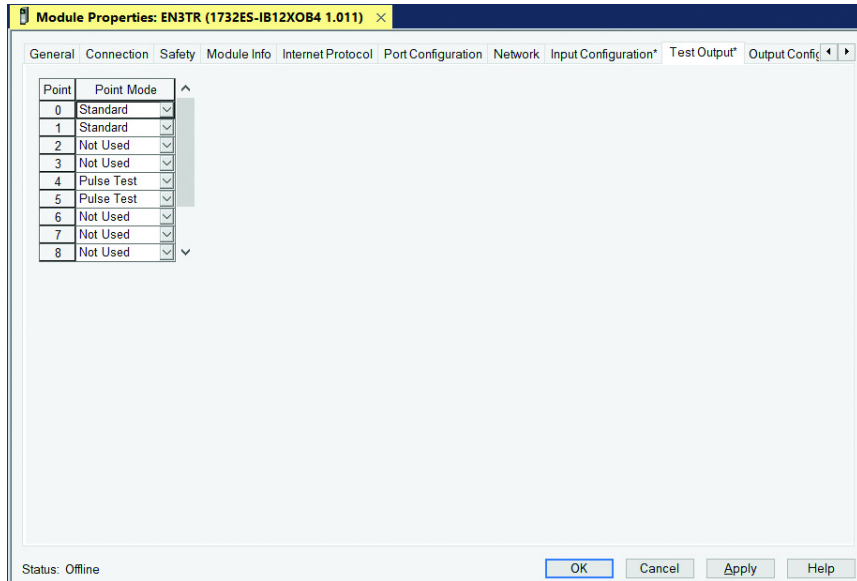

Figure 34 shows the Output Configuration tab of the ArmorBlock Module Properties. Points 0 and 1 drive the output contactors K1 and K2. The point Types are set to Dual, and the Modes are set to Safety.

Figure 34 - Module Properties - Output Configuration

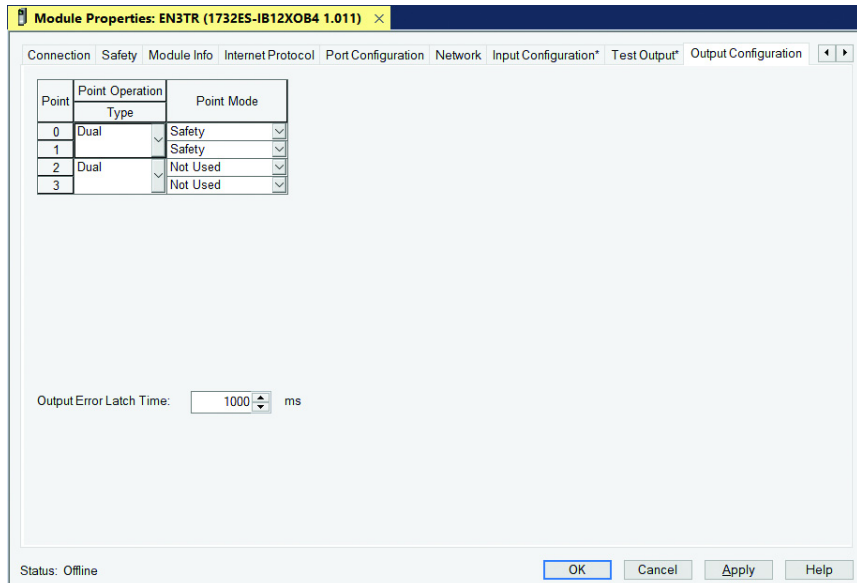
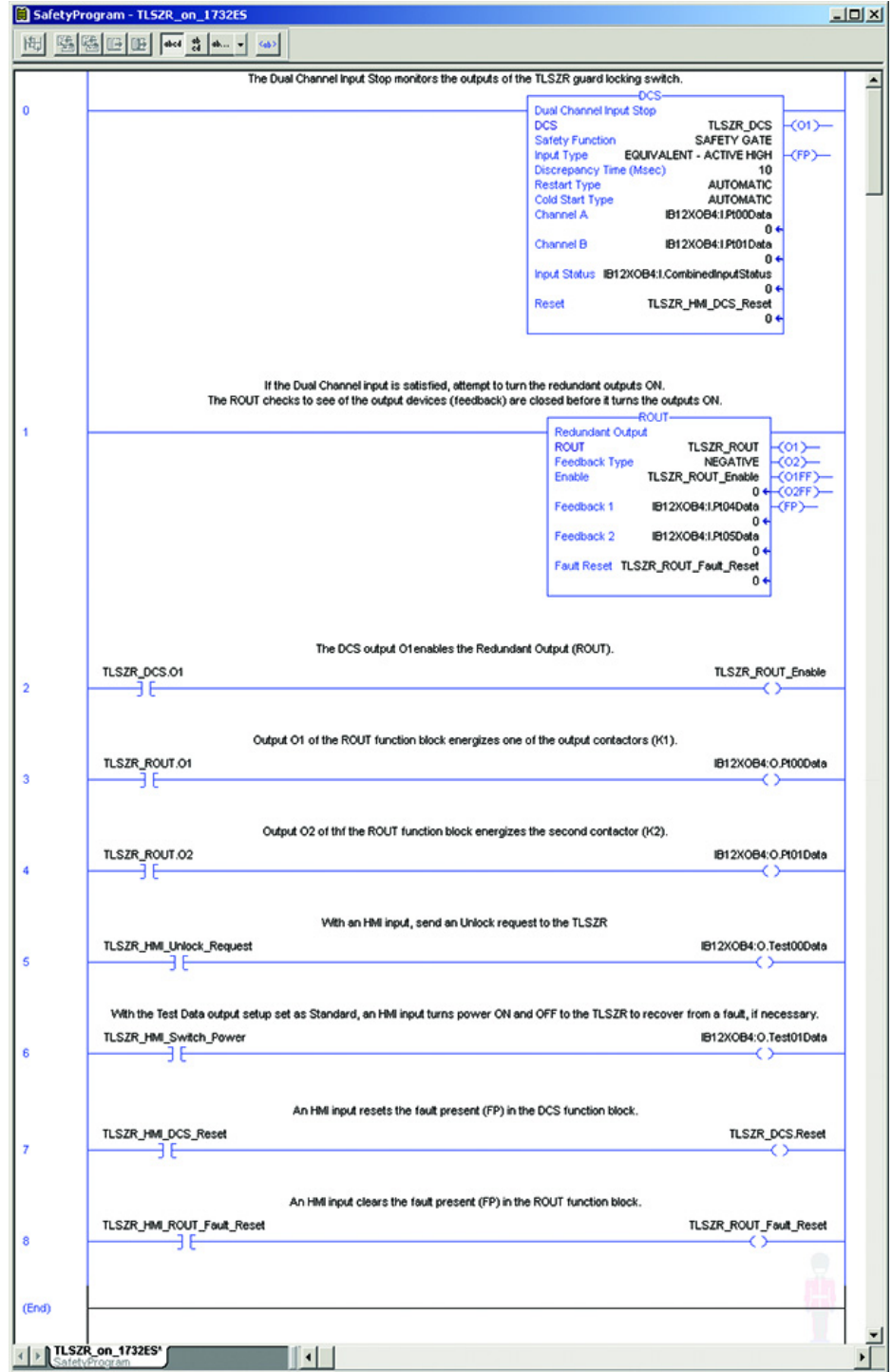

Figure 35 shows an example program. A Dual Channel Input Stop function block monitors the TLSZR guard locking switch and a Configurable Redundant Output function block controls two contactors. This example can be used as a starting point for implementation; based on the risk assessment for the machine, you can incorporate additional logic.

Figure 35 - Example Studio 5000 Program



Diagnostics and Troubleshooting

Persons who are trained in the safety of machine systems must conduct the troubleshooting procedures. This training includes knowledge of all sources of energy (for example electrical, pneumatic, safety, thermal, and others).

To troubleshoot TLSZ guard locking switches, observe the status indicator on the guard locking switch and follow the flow diagram in [Figure 36 on page 40](#).

Tools Needed

Required Tools

- T20 security-Torx screwdriver bit. The security Torx has a hollow center. This bit is required to remove the cover of the TLSZ guard locking switch.
- Medium-sized flat screwdriver for terminal screws, to remove terminal blocks, and to configure the guard locking switches on the front face of the relays.
- Digital multimeter (DMM) to measure signal levels and resistance.

Optional Tools

- Oscilloscope — dual or four-channel storage scope to view input and output signals and to capture signals and noise transients.
- Metal paper clips — to insert into the terminals and allow connection of scope probes to terminals.

Flowchart

Figure 36 shows a flow diagram to help diagnose the condition of the TLSZ guard locking switch.

Figure 36 - Troubleshooting Flow Diagram

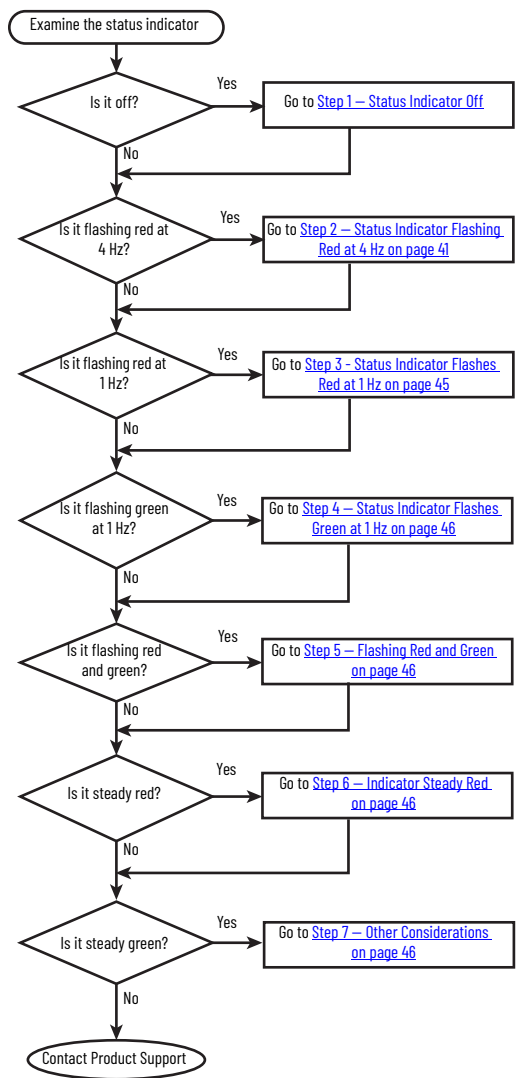

Step 1 – Status Indicator Off

When the status indicator is off, the TLSZ guard locking switch is not connected properly to either the 24V power supply or ground.

1. Use the Torx screwdriver to remove the TLSZ guard locking switch cover.
2. Use a digital multimeter (DMM) to measure the voltage at the power supply terminals (blue wire is 0V and brown wire is plus), as shown in [Figure 37 on page 41](#).

The voltage must measure between 20.4...26.4V DC.

Figure 37 - Measure the Voltage at the Power Supply Terminals

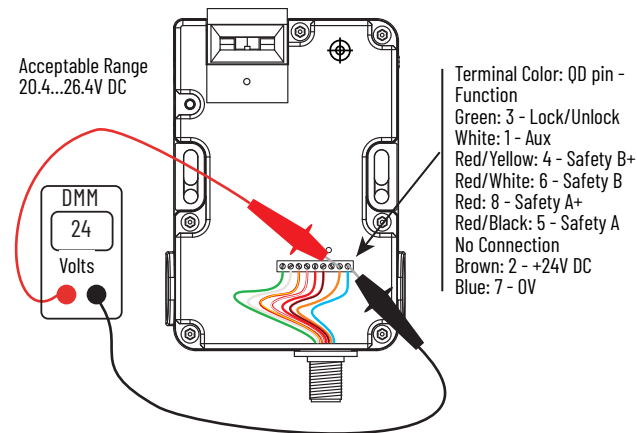

If 24V is present at the wiring terminals, check that the wires are stripped and the terminal screws are tight. If the wires are functional, replace the guard locking switch.

If 24V is not present at the terminals, check the power supply and the wiring up to the TLSZ guard locking switch.

Step 2 – Status Indicator Flashing Red at 4 Hz

The status indicator flashes red at 4 Hz when an inconsistency is detected with the RFID sensor. A number of scenarios can cause this fault indication.

Wrong Target

The TLSZ guard locking switch is configured to detect a specific target. If a non-configured target is presented to the TLSZ guard locking switch, the TLSZ goes into fault mode and its status indicator flashes red at 4 Hz.

To correct this condition:

1. Replace the incorrect target with a correct target.
2. Cycle the power to clear the fault.

From the factory, the TLSZ guard locking switch is not configured to detect any target. You must configure the TLSZ guard locking switch to detect a target. The configuration can be a one-time event, or the TLSZ guard locking switch can be configured to learn up to eight different targets. The TLSZ guard locking switch can only recognize one target. If the target gets damaged, the TLSZ guard locking switch can be configured to learn another target, if the initial configuration is set to multi-time learning, see [Commissioning Errors on page 19](#).

Missing Target

If the actuator is inserted into the TLSZR guard locking switch without the target present, the status indicator flashes red at 4 Hz.

To correct this condition:

1. Remove the actuator from the guard locking switch.
2. Cycle power to the TLSZR guard locking switch
3. Mount the target next to the actuator as shown in [Figure 38 on page 42](#).

Insert the actuator/target into the guard locking switch.

Target Not Mounted Correctly

If the actuator is mounted incorrectly, the TLSZ can operate correctly, but with reduced tolerance to misalignment of the target. The status indicator intermittently goes to a fault state with the status indicator flashing red at 4 Hz.

To correct this condition:

1. Remove the actuator/target from the guard locking switch.
2. Cycle power to the TLSZ guard locking switch to clear the fault.
3. Mount the target next to the actuator as shown in [Figure 38](#).
4. Insert the actuator/target into the guard locking switch.

Figure 38 - Mounting of Target and Actuator

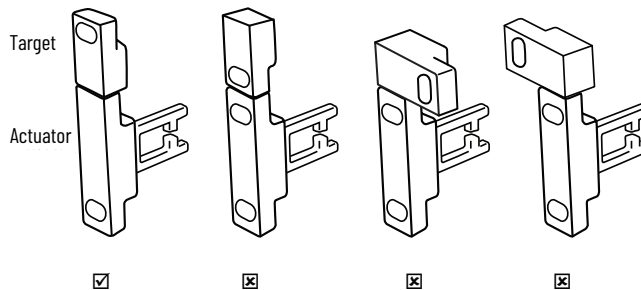

Pair Proximity

The RF field from a neighboring guard locking switch can cause intermittent faults. Guard locking switches with similar RF technology include the TLSZ, the SensaGuard™ switches, and the 440G-LZ guard locking switches.

To correct this condition:

1. Confirm that the neighboring switches are mounted at least 200 mm (8 in.) from any edge of the TLSZ guard locking switch.
2. Cycle power to the TLSZ guard locking switch to clear the fault.

Mechanical Pressure on Safety Gate

If a mechanical load (pressure) is applied to the gate during unlocking, the TLSZR guard locking switch goes to a fault mode. The status indicator flashes green three times and then red once. It repeats this process for 10 seconds, and then the status indicator flashes red at 4 Hz. Firmware 1.003 and earlier have a 10-second limit. Firmware 1.004 attempts to lock for 10 minutes.

1. Check the allowable spacing between the TLS and mechanical gate stop.
2. Adjust the spacing to be between 1 mm (0.04 in.) and 4 mm (0.16 in.) between the actuator and the metal guide as shown in [Figure 39 on page 43](#).
3. Cycle power to the TLSZ guard locking switch to clear the fault.

The safety gate needs some freedom to move when locked.

Figure 39 - Clearance in Closed Position [mm (in.)]

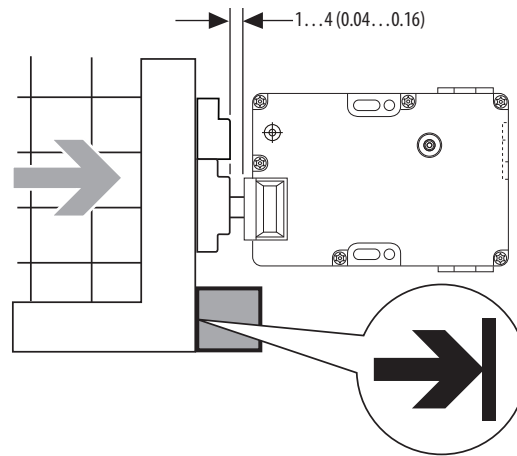

Long Wiring

Long input wiring adds resistance and decreases the supply voltage to the guard locking switch and reduces the safety OSSD outputs. The size of the wire also makes a difference; smaller wires have higher resistance.

[Figure 40](#) shows the typical TLSZ guard locking switch test pulses when connected to a resistive load with short [2 m (6.56 ft)] wiring. The test pulses are about 25 ms wide.

IMPORTANT The OSSD outputs are about 23V and the test pulses go to zero volts.

Figure 40 - TLSZ Test Pulses Into a 1K Resistive Load

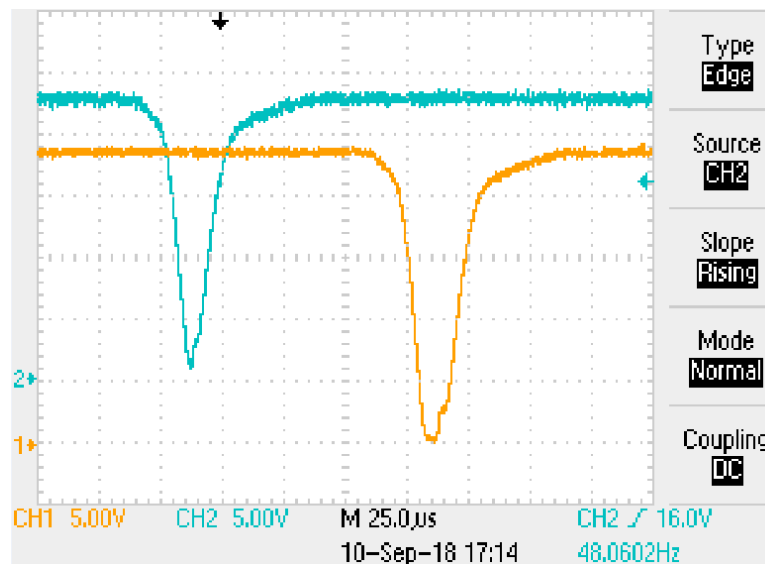

In [Figure 41 on page 44](#), TLSZR and GSR-SI guard locking switches operate successfully with long wiring. The OSSD outputs drop to approximately 21V and the test pulses only drop to approximately 8V (not 0V).

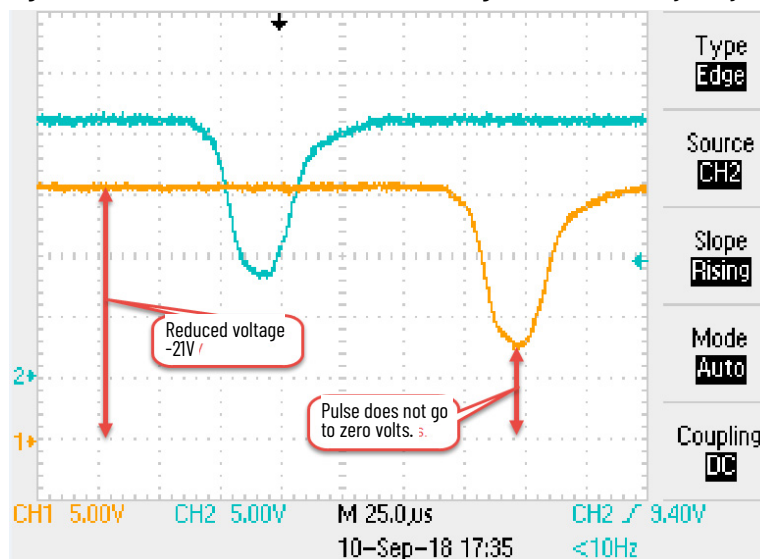
Figure 41 - Effect of 300 Ω of Wire Resistance Going Into a GSR-SI Safety Relay

Voltage Supply Dips

When the TLSZ guard locking switch solenoid energizes, it causes a 350 mA inrush current on the power supply wire. If multiple TLSZ guard locking switches energize simultaneously, the voltage supply can dip below the 20.4V voltage specification and cause the guard locking switch to go into fault mode.

Voltage drop is by:

1. The number of guard locking switches being energized simultaneously.
2. The power supply wire size.
3. The wire length.

IMPORTANT The lock/unlock command on the TLSZ guard locking switch is not like the older TLS1, TLS2, and on the TLSZ (both Power to Lock and Power to Release) is a logic level signal; about 3...5 mA. The power to energize the solenoid is provided by the brown power supply wire.

To avoid the power supply dip, we recommend that you stagger the lock/unlock command to successive guard locking switches by at least 170 ms.

Rapid Locking

The TLSZL Power to Lock switches cannot withstand rapid locking and unlocking. This action results in the indicator flashing red at 4 Hz. Although TLSZR Power to Release switches are more tolerant to rapid unlocking/locking, they can also go to a fault state with the indicator flashing red at 4 Hz.

We recommend you check that the locking operation frequency is no faster than 1 Hz with 50% duty cycle (500 ms lock, 500 ms unlock).

Step 3 - Status Indicator Flashes Red at 1 Hz

This status indicates that an undetermined fault has occurred.

Cycle the power. If the guard locking switch does not recover, cycle it again. If the guard locking switch does not recover, then run a separate cable directly from the power supply to the guard locking switch. This cable can run on the floor away from any extraneous signals. You can also provide a temporary selector switch to execute the lock/unlock command.

- Case 1: Switch Operates OK. Check the routing of the cable from the power supply to the guard locking switch. Be sure of adequate separation of guard locking switch cabling to sources of electromagnetic noise, such as drives and motion systems.
- Case 2: Switch Faults. If the guard locking switch fails with the cabling on the floor (clear of all electromechanical noise), then replace the guard locking switch.

Capacitive Loading

The OSSD outputs of the TLSZ guard locking switch use pulse testing to detect faults. The pulse testing is subjected to the capacitive loading of the cabling (longer cabling creates additional capacitance) and capacitance from the device to which it is connected.

Cable capacitive loading is not an intermittent issue. Once resolved, the capacitance can remain unchanged until conditions, such as cabling changes, occur.

Use an oscilloscope to measure the pulse tests. [Figure 42](#) shows the typical effect; the curved leading edge indicates capacitive loading.

The TLSZR guard locking switch can withstand a capacitive load up to 375 nF. Higher capacitance causes the OSSD outputs to turn off and the indicator flashes red at 1 Hz. Higher levels of capacitance can be tolerated by adding a 10K resistor from the OSSD signal to ground.

Figure 42 - Typical Capacitive Effect on Pulse Tests

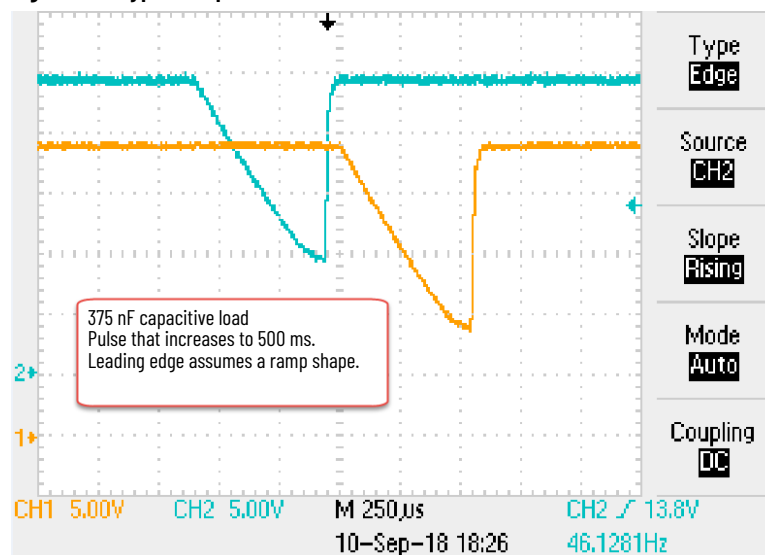

Step 4 – Status Indicator Flashes Green at 1 Hz

When the status indicator is flashing green at 1 Hz, the guard locking switch is indicating that it is waiting for 24V to be applied to the OSSD A+ and OSSD B+ input signals.

Upon power-up, the TLSZ guard locking switch performs internal checks. During this time, the status indicator flashes green three times, shows steady red for about 2 seconds. If the OSSD A+ and OSSD B+ inputs are not connected to 24V, the status indicator then flashes green at 1 Hz.

Corrective Action:

1. If you have multiple guard locking switches that are connected in series, check the OSSD outputs of the prior guard locking switch.
 - a. If the prior guard locking switch is flashing green, go to then next prior guard locking switch to determine why its OSSD outputs are off.
 - b. If the TLS is the only guard locking switch or the first guard locking switch in a series connection of switches, check the power supply connections of OSSD A+ (red wire) and OSSD B+ (yellow wire).

Step 5 – Flashing Red and Green

The TLSZ guard locking switch was initially configured for multi-time use. The flashing red and green indicator indicates the number of configurations that can be completed, see [Commissioning on page 17](#).

Step 6 – Indicator Steady Red

The steady red indicator occurs when specific faults have not been detected.

1. Try to cycle power.
2. Remove the cable and reconnect the guard locking switch to a separate cable and use the existing power supply.
 - If the guard locking switch recovers, check the existing cable routing to verify that the guard locking switch cable is not along motor or other high-noise wiring. Also check the grounding scheme, the 0V of the guard locking switch must be very close to the safety logic device to which it interfaces.
 - If the guard locking switch does not recover, proceed to [step 3](#).
3. Remove the guard locking switch from the installation and apply a bench test circuit.
 - If the guard locking switch still exhibits a steady red indicator, replace the guard locking switch.
 - If the guard locking switch recovers, then re-examine the cable routing and the grounding scheme.

Step 7 – Other Considerations

Distribution Block

The TLZ guard locking switch can be connected the catalog number 898D distribution block. The distribution block is available with either four or eight ports. An example with eight ports is shown in [Figure 43 on page 47](#). This application requires special considerations:

1. The cable lengths in this example are all 30 m (98.4 ft) long. The cable length causes a 1.5V drop in power at the guard locking switch.
2. If the power supply is set to 24V, the voltage at the terminals inside each guard locking switch is 22.5V.

Common Lock Signal

The lock/unlock command is simultaneously applied to all eight guard locking switches. Each guard locking switch has a 300 mA nominal (350 mA max) inrush current that lasts about 110 ms (see Figure 44). With all eight guard locking switches locked/unlocked at the same, the inrush current is 2.4 A. The power supply must be able to accommodate this inrush.

Figure 43 - TLSZ Guard Locking Switch with 898D Distribution Block

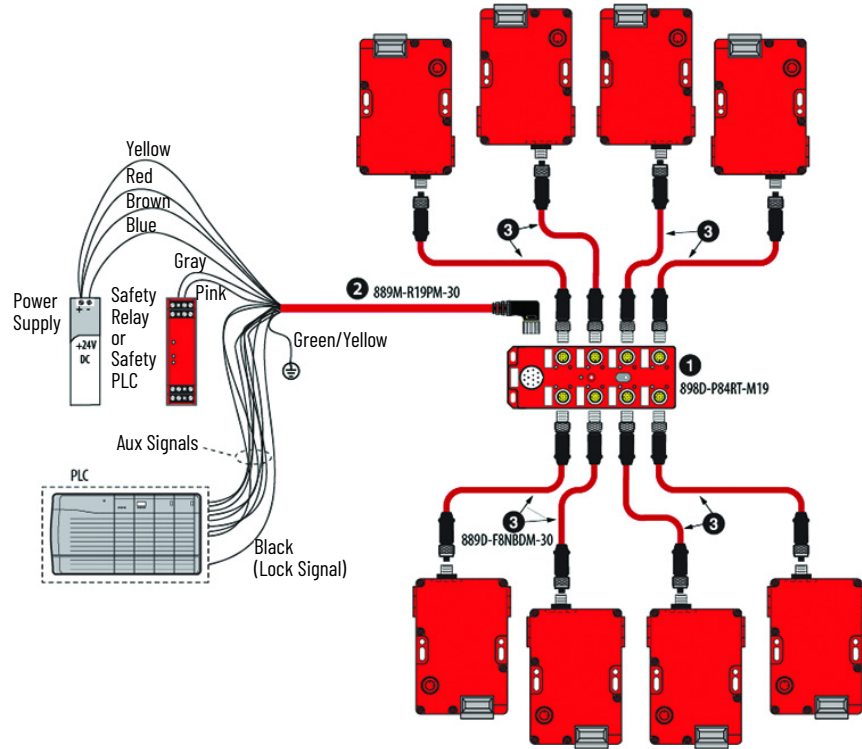
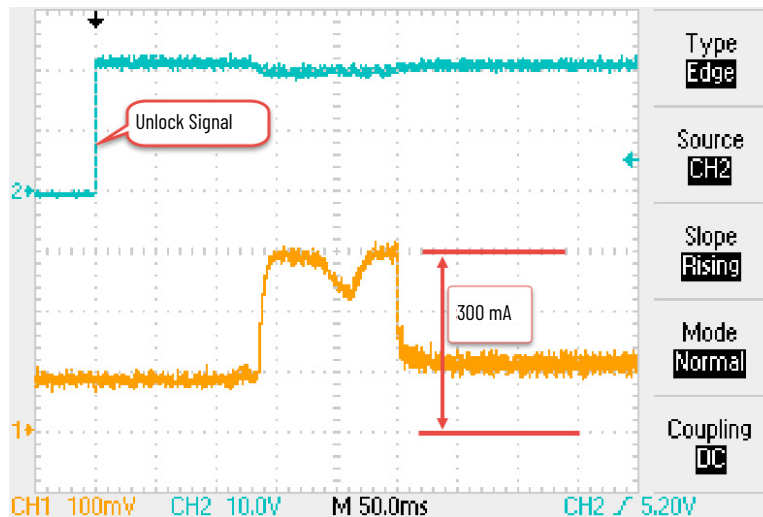

Figure 44 - Inrush Current on the Power Supply at the Guard Locking Switch



GSR Relays on Power-up

Upon power-up, the Guardmaster® safety relays (GSR) input does not recognize the status of the TLSZ guard locking switch outputs; the IN1 indicator remains off. The TLSZR guard locking switch must be unlocked and then locked. Then the GSR relay recognizes the OSSD outputs of the TLS. This sequence only occurs on power-up and is a function of the GSR (not the TLSZ guard locking switch).

Specifications

Safety Ratings

| Attribute | 440G-TZS2IUPRH, 440G-TZS2IUPLH, 440G-TZS2IUTRH, 440G-TZS2IUTLH |
|-----------------------------------|---|
| Standards | IEC 60947-5-3, IEC 60947-5-1, IEC 62061, IEC 61508, ISO 13849-1, ISO 14119 |
| Category per ISO 13849-1 | 4 |
| Performance Level per ISO 13849-1 | PLe, includes guard door position and lock monitoring |
| SIL claim limit per IEC 62061 | 3 |
| PFHd [1/h] | 1.70E-09 |
| Proof test interval | 20 years |
| Certifications | CE Marked for all applicable directives, UKCA marked for all applicable regulations, cULus Listed (UL 508), and TUV Certified |

Operating Characteristics

| Attribute | 440G-TZS2IUPRH, 440G-TZS2IUPLH, 440G-TZS2IUTRH, 440G-TZS2IUTLH |
|--|---|
| TLSZR-GD2 | Power to Release |
| TLSZL-GD2 | Power to Lock |
| Assured locking distance | 13 mm (0.51 in.) Maximum target distance 4 mm (0.16 in.) Maximum clearance between actuator base and switch in the door closed position |
| Torque for M5 mounting | 1.4 N•m (12.39 lb•in) |
| Torque for cover mounting | 1.2 N•m (10.62 lb•in) |
| Locking force F_{max} | <ul style="list-style-type: none"> Plastic pins: 1950 N (488 lb) Steel bolts: 2600 N (585 lb) |
| Locking force F_{zh} per EN/ISO 14119 | <ul style="list-style-type: none"> Plastic pins: 1500 N (337 lb) Steel bolts: 2000 N (450 lb) |
| Maximum output current (all outputs) | 200 mA |
| Current consumption | <ul style="list-style-type: none"> Solenoid not energized, no output load: 75 mA Solenoid energized, no output load: 120 mA Inrush current: 350 mA |
| Solenoid duty cycle | 100% |
| Off-state current | < 0.5 mA DC |
| Maximum number of switches connected in series | Unlimited |
| Operating voltage U_e | 24V DC +10% / -15%, Class 2 Source Required |
| Frequency of solenoid operating cycle | 1 Hz, max |
| Actuation speed | 160 mm/s (6.29 in/s), max 100 mm/min (3.94 in/min), min |
| Response time (off) | 75 ms first switch, 25 ms additional for each switch |
| Utilization Category per IEC 60947-5-2 | DC-13, 24V 200 mA |
| Impulse withstand voltage U_{imp} | 250V |
| Protection class | 2 |
| Mechanical life | 1,000,000 cycles |

Environmental

| Attribute | 440G-TZS2IUPRH, 440G-TZS2IUPLH, 440G-TZS2IUTRH, 440G-TZS2IUTLH |
|-------------------------------|---|
| Operating temperature | -10...+60 °C (14...140 °F) |
| Operating humidity | 5...95% |
| Risk time, max ⁽¹⁾ | 60 ms |
| Rated insulation voltage Ui | 500V |
| Enclosure ingress rating | NEMA 3, 4X, 12, 13, IP66, IP67, IP69K |
| Shock per IEC 68-2-27 | 30 g, 11 ms |
| Vibration IEC 68-2-6 | 10...55 Hz, 0.35 mm |
| Radio frequency | IEC 61000-4-3 IEC 61000-4-6 |
| Pollution degree | 3 |
| Altitude, max | 2000 m (6562 ft) |

(1) If the RFID door target moves outside of the operating distance, the safety outputs are deactivated

General

| Attribute | 440G-TZS2IUPRH, 440G-TZS2IUPLH, 440G-TZS2IUTRH, 440G-TZS2IUTLH |
|-----------------|--|
| Material | <ul style="list-style-type: none"> Housing: UL Approved glass-filled PBT Actuator: Stainless steel Target: UL Approved glass-filled PBT |
| Connection | M12 8-pin connector |
| Protection type | Short circuit |

Declaration of Conformity

CE Conformity

Rockwell Automation declares that the products that are shown in this document are in compliance with all applicable EU Directives.

For a comprehensive CE certificate visit rok.auto/certifications.

UKCA Conformity

Rockwell Automation declares that the products that are shown in this document are in compliance with all applicable UK Regulations.

For a comprehensive UKCA certificate visit rok.auto/certifications.

Numerics

1732 ArmorBlock

wiring 35

1734 POINT Guard I/O

wiring 31

A

actuator

clearance 12

mount 9

additional target

learn 18

allowable approach direction 9

application

example 23

approach direction

allowable 9

audience 5

auxiliary 24

output 16

C

catalog number explanation 7

clearance

actuator 12

close coupled 9

commission 17

error 19

preparation 17

wiring 17

connection 15

consideration

installation 9

content

packaging 8

cover

manual override 11

CR30 relay

wiring 28

D

DG relay

wiring 27

DI relay

wiring 26

diagnostics 39

dimensions 13

direction

allowable approach 9

E

EMD relay

wiring 26

error

commission 19

example

application 23

wiring 23

F

first target

learn 18

first time

power-up 18

flowchart

troubleshooting 40

functional test 21

G

GLP relay

wiring 23

GLT relay

wiring 24

guide

reposition 11

H

holding force 12, 13

I

input

OSSD 15

installation 9

consideration 9

L

learn

additional target 18

first target 18

lock command 16

locking bolt

steel 12

M

manual override cover 11

manual release 10

mount

actuator/target 9

O

operating radius

minimum 10

OSSD

input 15

output 15

output
 auxiliary 16
 OSSD 15
overview 7

P

packaging content 8
pair proximity 11
power-up
 first time 18
 self-check 19
preparation
 commission 17
purpose 5

R

radius
 operating 10
rating
 safety 49
release
 manual 10
reposition
 guide 11

S

safety rating 49
self-check
 power-up 19
steel locking bolt 12

T

target
 learn additional 18
 learn first 18
 mount 9
terminology 6
test
 functional 21
 procedure 21
troubleshooting 39
 flowchart 40

W

wiring 15
 commission 17
 example 23
 to 1732 ArmorBlock 35
 to 1734 POINT Guard I/O 31
 to CR30 relay 28
 to DG relay 27
 to DI and EMD relay 26
 to GLP relay 23
 to GLT relay 24

Rockwell Automation Support

Use these resources to access support information.

| | | |
|---|--|--|
| Technical Support Center | Find help with how-to videos, FAQs, chat, user forums, and product notification updates. | rok.auto/support |
| Knowledgebase | Access Knowledgebase articles. | rok.auto/knowledgebase |
| Local Technical Support Phone Numbers | Locate the telephone number for your country. | rok.auto/phonesupport |
| Literature Library | Find installation instructions, manuals, brochures, and technical data publications. | rok.auto/literature |
| Product Compatibility and Download Center (PCDC) | Download firmware, associated files (such as AOP, EDS, and DTM), and access product release notes. | rok.auto/pcdc |

Documentation Feedback

Your comments help us serve your documentation needs better. If you have any suggestions on how to improve our content, complete the form at rok.auto/docfeedback.

Waste Electrical and Electronic Equipment (WEEE)







At the end of life, this equipment should be collected separately from any unsorted municipal waste.

Rockwell Automation maintains current product environmental compliance information on its website at rok.auto/pec.

Allen-Bradley, ArmorBlock, Connected Components Workbench, expanding human possibility, GuardLink, Guardmaster, POINT Guard I/O, PowerFlex, Rockwell Automation, SensaGuard, and Studio 5000 are trademarks of Rockwell Automation, Inc.

Trademarks not belonging to Rockwell Automation are property of their respective companies.

Rockwell Otomasyon Ticaret A.Ş. Kar Plaza İş Merkezi E Blok Kat:6 34752, İçerenköy, İstanbul, Tel: +90 (216) 5698400 EEE Yönetmeliğine Uygundur

Connect with us.    

rockwellautomation.com ————— expanding **human possibility**[®]

AMERICAS: Rockwell Automation, 1201 South Second Street, Milwaukee, WI 53204-2496 USA, Tel: (1) 414.382.2000, Fax: (1) 414.382.4444

EUROPE/MIDDLE EAST/AFRICA: Rockwell Automation NV, Pegasus Park, De Kleetlaan 12a, 1831 Diegem, Belgium, Tel: (32) 2 663 0600, Fax: (32) 2 663 0640

ASIA PACIFIC: Rockwell Automation, Level 14, Core F, Cyberport 3, 100 Cyberport Road, Hong Kong, Tel: (852) 2887 4788, Fax: (852) 2508 1846