

SC300 Safety Sensor User Manual

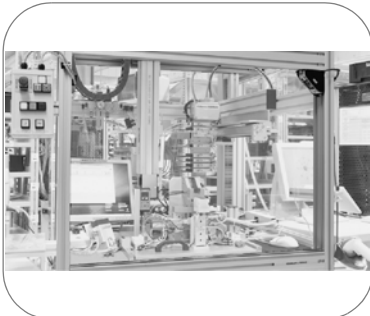

Important User Information

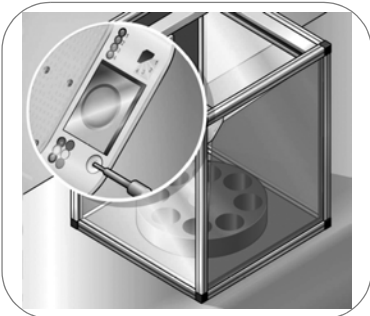



Because of the variety of uses for the products described in this publication, those responsible for the application and use of this control equipment must satisfy themselves that all necessary steps have been taken to assure that each application and use meets all performance and safety requirements, including any applicable laws, regulations, codes and standards.

The illustrations, charts, sample programs and layout examples shown in the guide are intended solely for purposes of example. Since there are many variables and requirements associated with any particular installation, Rockwell Automation does not assume responsibility or liability (to include intellectual property liability) for actual use based upon the examples shown in this publication.

Rockwell Automation publication SGI-1.1, Safety Guidelines for the Application, Installation and Maintenance of Solid-State Control (available from your local Rockwell Automation sales office), describes some important differences between solid-state equipment and electromechanical devices that should be taken into consideration when applying products such as those described in this publication.

Reproduction of the contents of this copyrighted publication, in whole or part, without written permission of Rockwell Automation, is prohibited.

Throughout this manual we use notes to make you aware of safety considerations:

WARNING 	Identifies information about practices or circumstances that can cause an explosion in a hazardous environment, which may lead to personal injury or death, property damage, or economic loss.
IMPORTANT	Identifies information that is critical for successful application and understanding of the product.
ATTENTION 	Identifies information about practices or circumstances that can lead to personal injury or death, property damage, or economic loss. Attentions help you identify a hazard, avoid a hazard, and recognize the consequences.
SHOCK HAZARD 	Labels may be on or inside the equipment (for example, drive or motor) to alert people that dangerous voltage may be present.
BURN HAZARD 	Labels may be on or inside the equipment (for example, drive or motor) to alert people that surfaces may reach dangerous temperatures.

It is recommended that you save this user manual for future use.

Contents

About This Document

Function of this document	5
Target group	5
Information depth	5
Scope	6
Abbreviations used	6
Symbols used	6

On Safety

Qualified safety personnel	8
Applications of the device	8
Correct use	9
General safety notes and protective measures	9
Environmental protection	10
Disposal	10

Product Description

Special features	11
Operating principle of the device	11
Application examples	12
Configurable functions	12
Restart interlock	13
External device monitoring (EDM)	14
Status indicators	15
Status LEDs of the SC300	15
Diagnostics LEDs of the SC300	15

Mounting

Checking the dimensions of the protective field	17
Protective field dimensions allowed at a resolution of 20 mm	17
Protective field dimensions allowed at a resolution of 24 mm	18
Protective field dimensions allowed at a resolution of 30 mm	18
Determining the safety distance	18
Safety distance according to prEN ISO 13 855 and EN ISO 13 857	19
Safety distance if OSHA and ANSI are applicable	21
Avoiding unmonitored areas	22
Steps for mounting the safety sensor system	24
Mounting on a frame	25
Mounting in a frame	26
Mounting the reflective tape	26

Electrical Installation

System connection M12 × 8	30
Connecting the SC300	30
Two SC300 with synchronization	32
Connection diagrams	33
SC300 on UE10-30S with external device monitoring (EDM) and internal restart interlock	34

Application Examples	
Application with one SC300	37
Application with two SC300	37
Application with safe access on three sides (ergonomic workplace design) ..	38
Application with automatic material transport to the workstation.	39
Commissioning	
Test notes	40
Pre-commissioning tests	40
Regular inspection of the protective device by qualified safety personnel ...	40
Tests of the protective device by a specialist or authorized personnel	41
Configuration	
Teach-in	42
Internal restart interlock	44
External device monitoring	44
Locking the internal teach-in key	45
Care and Maintenance	
Fault Diagnosis	
In the event of faults or errors	47
Rockwell Automation support	47
Warnings and error messages of the LEDs	47
Technical Specifications	
Data sheet	49
Dimensional drawings	52
Dimensional drawing SC300	52
Dimensional drawing, mounting kit	53
Ordering Information	
Safety sensor systems	54
Accessories	55
Annex	
Checklist for the manufacturer	56
Compliance with EU Directives	57
List of tables	58
List of illustrations	58

Chapter 1

About This Document

Please read this chapter carefully before working with the documentation and the SC300 safety sensor system.

Function of this document

These operating instructions are designed to address the *technical personnel of the machine manufacturer* or the *machine operator* in regards to safe mounting, installation, configuration, electrical installation, commissioning, operation and maintenance of the SC300 safety sensor system.

These operating instructions do not provide instructions for operating machines on which the SC300 safety sensor system is, or will be, integrated. Information on this is to be found in the operating instructions for the machine.

Target group

These operating instructions are addressed to *planning engineers, machine designers* and *operators* of plants and systems which are to be protected by one or several SC300 safety sensor systems. It also addresses people who integrate the SC300 into a machine, initialize its use, or who are in charge of servicing and maintaining the device.

Information depth

These operating instructions contain the following information on the SC300 safety sensor system:

- mounting
- electrical installation
- commissioning
- care and maintenance
- fault diagnosis and troubleshooting
- part numbers
- conformity and approval

Planning and using protective devices such as the SC300 also require specific technical skills which are not detailed in this documentation.

When operating the SC300, the national, local and statutory rules and regulations must be observed.

General information on accident prevention using opto-electronic protective devices can be found in the brochure "Safe Machines with opto-electronic protective devices."

Note Please refer also to the Rockwell Automation homepage on the internet at www.rockwellautomation.com.

Here you will find information on:

- Application examples and application reports that supplement the application examples
- A list of frequently asked questions regarding the SC300
- These operating instructions in different languages for viewing and printing
- Certificates on the prototype test, the EC declaration of conformity and other documents.

Scope

This document is an original document.

Notes These operating instructions are only applicable to the SC300 safety sensor system with the following entry on the type label in the field *Operating Instructions*: 10000202762.

Abbreviations used





- ANSI** American National Standards Institute
- EDM** External device monitoring
- ESPE** Electro-sensitive protective equipment (e.g. SC300)
- LED** Light Emitting Diode
- OSSD** Output signal switching device = signal output from the protective device to the controller that is used to stop the dangerous movement
- SC300** Short code for the SC300 safety sensor system

Symbols used







Recommendation Recommendations are designed to give you some assistance in your decision-making process with respect to a certain function or a technical measure.

Note Refer to notes for special features of the device.

 LED symbols describe the status of an LED. Examples:

-  The LED is off.
-  The LED is illuminated constantly.
-  The LED flashes evenly (0.5 seconds on, 0.5 seconds off).
-  The LED goes off briefly (0.9 seconds on, 0.1 seconds off, ...).
-  The LED flashes with a short duty cycle (0.9 seconds off, 0.1 seconds on, ...).

 In combination with the LED symbols, these symbols identify which LED is described:

-   The LED "Stop" (OSSDs switched off) is illuminated constantly.
-   The LED "Warning" flashes.
-   The LED "OK" (OSSDs switched on) is off.

➤ **Take action ...** Instructions for taking action are shown by an arrow. Read carefully and follow the instructions for action.

Attention



Potentially hazardous situation, which, if not prevented, might lead to serious or deadly injury.
Failure to observe may result in dangerous operation.

The term “dangerous state”

The dangerous state (standard term) of the machine is always shown in the drawings and diagrams of this document as a movement of a machine part. In practical operation, there may be a number of different dangerous states:

- Machine movements
- Electrical conductors
- Visible or invisible radiation
- A combination of several risks and hazards.

On Safety

This chapter deals with your own safety and the safety of the equipment operators.

- Please read this chapter carefully before working with the SC300 or with the machine protected by the SC300.

Qualified safety personnel

The SC300 safety camera system must only be installed, commissioned and serviced by qualified safety personnel. Qualified safety personnel are defined as persons who:

- Due to their specialist training and experience have adequate knowledge of the power-driven equipment to be checked

and

- Have been instructed by the responsible machine owner in the operation of the machine and the current valid safety guidelines

and

- Are sufficiently familiar with the applicable official health and work safety regulations, directives and generally recognized engineering practice (e.g. DIN standards, VDE stipulations, engineering regulations from other EC member states) that they can assess the work safety aspects of the power-driven equipment

and

- Have access to these operating instructions and have read them.

As a rule these are qualified safety personnel from the ESPE manufacturer or also persons who have been appropriately trained at the ESPE manufacturer, are primarily involved in checking ESPE and are allocated the task by the organization operating the ESPE.

Applications of the device

The SC300 safety camera system is an item of electro-sensitive protective equipment (ESPE).

The SC300 safety camera system can be operated with three resolutions. Depending on the resolution used, the maximum protective field dimensions change:

Resolution [mm]	Protective field dimensions [m]		
	Minimum	Maximum	Note
20	0.40 × 0.40	1.00 × 1.00	On sizing the protective field the ratio for the lengths of the sides must be considered (see "Checking the dimensions of the protective field" on page 17).
24	0.40 × 0.40	1.20 × 1.20	
30	0.60 × 0.60	1.50 × 1.50	

Table 1 - Maximum protective field dimensions as a function of the resolution

The device is a *Type 3 ESPE* (SC300 safety camera) according to EN 61 496-1 and IEC/TR 61 496-4 and is therefore allowed for use with controls in Category 3 according to EN ISO 13849-1. The device is suitable for hazardous point protection (hand protection).

Access to the hazardous point must be allowed only through the protective field. As long as the hazardous point is occupied, the system must not start. Refer to “Applications Examples” on page 12 for an illustration of the protection modes.

ATTENTION

Only use the safety sensor system as an indirect protective measure!

An opto-electronic protective device provides indirect protection, e.g. by switching off the power at the source of the hazard. It cannot provide protection from parts thrown out, nor from emitted radiation. Transparent objects are not detected.

Depending on the application, mechanical guards may be required in addition to the safety camera system.

The safety camera system is only intended for use in industrial environments. When used in residential areas it can cause radio interferences.

Correct use

The SC300 safety camera system must be used only as defined in the “Applications of the device” on page 8. It must be used only by qualified personnel and only on the machine where it has been installed and initialized by qualified safety personnel in accordance with these operating instructions.

If the device is used for any other purposes or modified in any way — also during mounting and installation — any warranty claim against Rockwell Automation shall become void.

General safety notes and protective measures

ATTENTION

Pay attention to the safety notes!

Please observe the following procedures for proper use of the SC300 safety sensor system.

- The national/international rules and regulations apply to the installation, use and periodic technical inspections of the safety camera system, in particular:
 - Machinery Directive 2006/42/EC
 - Work Equipment Directive 89/655/EEC
 - The work safety regulations/safety rules
 - Other relevant safety regulations

Manufacturers and operators of the machine on which the safety camera system is used are responsible for obtaining and observing all applicable safety regulations and rules.

- The notices, in particular the test regulations (see “Test Notes” on page 40) of these operating instructions (e.g. on use, mounting, installation or integration into the existing machine controller) must be observed.
- Tests must be carried out by qualified safety personnel and must be recorded and documented to ensure that the tests can be reconstructed and retraced at any time.
- Changes to the configuration of the devices can degrade the protective function. After every change to the configuration you must therefore check the effectiveness of the protective device. The person who makes the change is also responsible for the correct protective function of the device.

- The light beams from the camera may be deflected by reflective surfaces. This can result in failure to identify an object. For this reason reflective surfaces on the reflective tape or in the protective field are not allowed.
- The operating instructions must be made available to the operator of the machine where the SC300 safety camera system is fitted. The machine operator is to be instructed in the use of the device by qualified safety personnel and must be instructed to read the operating instructions.
- To meet the requirements of the relevant product standards (e.g. EN 61 496-1), the external voltage supply for the devices (SELV) must be able to bridge a brief mains failure of 20 ms. Power supplies according to EN 60 204-1 satisfy this requirement. Suitable power supplies are available as accessories from Rockwell Automation(see the “Accessories” section on page 55).

Environmental protection

The SC300 safety camera system has been designed to minimize environmental impact. It uses only a minimum of power and natural resources.

- At work, always act in an environmentally responsible manner.

Disposal

- Always dispose of unserviceable or irreparable devices in compliance with local/national rules and regulations with respect to waste disposal (e.g. European waste code 16 02 14).

Separation of materials

Before you send the devices for appropriate recycling, it is necessary to separate the different materials in the SC300 safety camera.

- Separate the housing from the rest of the parts (in particular the circuit board).
- Send the separated parts for recycling as appropriate:

Components	Disposal
Product	
Housing	Metal recycling (aluminium)
Circuit boards, cable, connector and electrical connecting pieces	Electronic recycling
Packaging	
Cardboard, paper	Paper/cardboard recycling
Polyethylene packaging	Plastic recycling

Product Description

This chapter provides information on the special features and properties of the SC300 safety camera system. It describes the construction and the operating principle of the device, in particular the different operating modes.

- Please read this chapter before mounting, installing and commissioning the device.

Special features

- SC300 Type 3 ESPE according to EN 61 496-1 complies with the requirements for the “Control reliable” safety level.
- Protective operation with either internal or external (realized on the machine) restart interlock
- Facility for connecting a reset button
- Facility for connecting an external device monitoring (EDM)
- Status indication by LED

Operating principle of the device

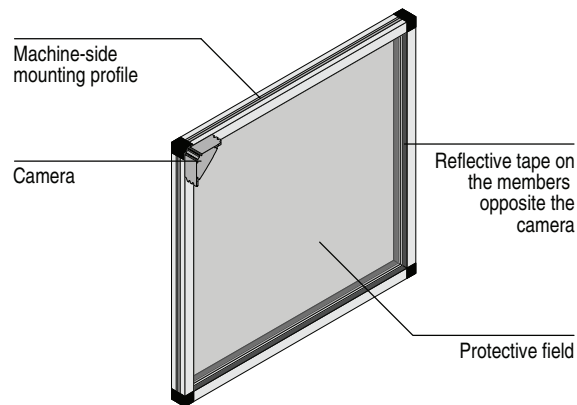

Figure 1 - Operating principle of the SC300

The SC300 safety camera system comprises a camera as well as a reflective tape with which the contour to be monitored is defined.

The camera monitors the area bounded by its field of view and the reflective tape – the protective field – for interruptions. If the SC300 detects an interruption in the shape of the protective field, the camera shuts down its safe outputs.

Please refer to “Technical Specifications” on page 49 for the data sheet. Please refer to page 52 for the dimensional drawings.

Application examples

Note The mounting of the device is only shown schematically in the following figures for reasons of simplicity.

For correct mounting, pay attention to the Mounting notes on page 17.

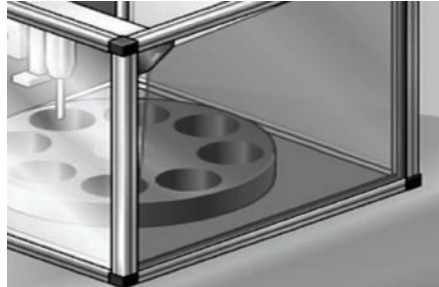

Figure 2 - Hazardous point protection with one SC300, mounting in the frame

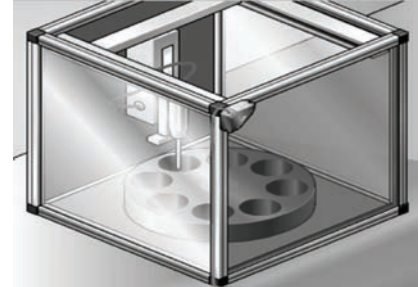

Figure 3 - Hazardous point protection with one SC300, mounting on the frame

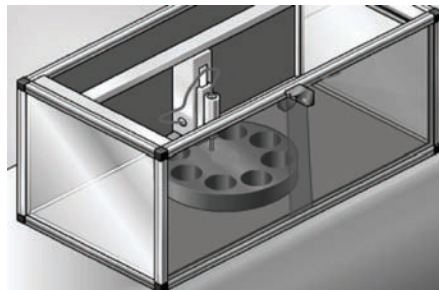

Figure 4 - Hazardous point protection with two SC300, placement in opposite directions

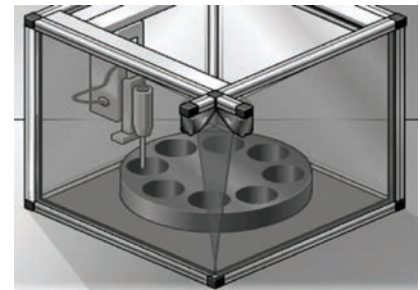

Figure 5 - Hazardous point protection with two SC300, placement at corner

The SC300 safety camera system operates correctly as a protective device only if the following conditions are met:

- The control of the machine must be electrical.
- It must be possible to achieve a safe state on the machine at any time.
- Camera and reflective tape must be so mounted that objects penetrating into the hazardous area are safely identified by the SC300.
- The reset button must be fitted outside the hazardous area such that it cannot be operated by a person working inside the hazardous area. When operating the reset button, the operator must have full visual command of the hazardous area.
- The statutory and local rules and regulations must be observed when installing and using the device.
- The necessary protective field dimensions must not exceed the permitted ratio for the lengths of the sides (see “Checking the Dimensions of the Protective Field” on page 17).

Configurable functions

This section describes the functions of the SC300 safety camera system that can be configured.

ATTENTION

Test the protective device after any changes.

After each modification to the protective device or its connection, you must check the whole protective device for effectiveness (see "Test Notes" on page 40).

Restart interlock

Figure 6 - Outline drawing of the protective operation

The SC300 has an internal restart interlock. The dangerous state of the machine (①) is interrupted on a protective field interruption (②), and is not re-enabled (③) until the operator presses the reset button.

- Notes**
- If you use the SC300 without internal restart interlock, then you must implement the restart interlock externally, i.e. machine-side.
 - Do not confuse the restart interlock with the starting interlock on the machine. The starting interlock guards against the machine starting after switching on. The restart interlock guards against the machine starting again after an error or an interruption of the light path.

When using the SC300, you can implement the restart interlock in two different ways:

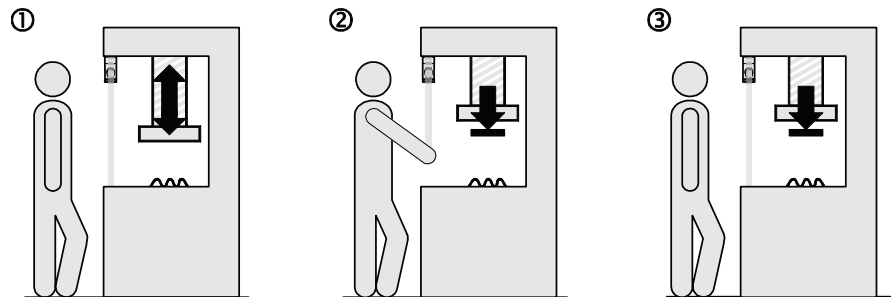
- With the internal restart interlock of the SC300:
The SC300 controls the restart.
- With the restart interlock of the machine (external):
The SC300 has no control over the restart.

The possible combinations are shown in the following table:

Restart interlock of the SC300	Restart interlock of the machine	Permissible application
Deactivated	Deactivated	Only if . . . the safety camera system cannot be stood behind. Observe EN 60 204-1! it is ensured no work clothing with reflectors is used.
Deactivated	Activated	All
Activated	Deactivated	Only if the safety camera system cannot be stood behind. Observe EN 60 204-1!
Activated	Activated	All. Restart interlock of the SC300 handles the reset function (see Reset below).

Table 2 - Permissible restart interlock configurations on the SC300

ATTENTION

Always configure the application with restart interlock.

Ensure that there is always a restart interlock. The SC300 is unable to verify if the restart interlock of the machine is connected. If you deactivate both the internal and the external restart interlock, the users and operators of the machine will be at acute risk of injury.

Reset

If you activate the restart interlock on the SC300 (internal) and also realize a restart interlock on the machine (external), then each restart interlock gets its own button.

When actuating the reset button (for the internal restart interlock) ...

- The SC300 activates the output signal switching devices.
- Switches the SC300 to green.





Only the external restart interlock guards against the machine from restarting. After pressing the reset button for the SC300, the operator must also press the restart button for the machine. If the reset button and the restart button are not pressed in the specified sequence, the dangerous state must remain disrupted.

Recommendation The reset button guards against the accidental and inadvertent operation of the external restart button. The operator must first acknowledge the safe state with the reset button.

The electrical connection of the reset button is described in the “Electrical Installation” section on page 29. The configuration of the internal restart interlock is described on page 44.

External device monitoring (EDM)

The SC300 has external device monitoring. If you activate the external device monitoring, then the SC300 checks whether the contactors are actually de-energized when the protective device triggers. If, after an attempted Reset/restart, the EDM does not detect a response from the switched device within 300 ms, the EDM will deactivate the output signal switching devices again. In this case the safety camera system signals as follows:

- The system remains at red. The status LED  illuminates.
- The status LED   flashes with a short duty cycle
- The diagnostics LED 2  flashes with a short duty cycle.

Note If the system is unable to change to a safe operational state (e.g. after contactor failure), the system locks and shuts down completely (“lock-out,” see page 47). The electrical connection for the external device monitoring is described in the “Connecting the SC300” section on page 30. The configuration of the external device monitoring is described in the “Configuration” chapter on page 42.

Status indicators

The light emitting diodes (LEDs) on the SC300 signal its operating status.

Status LEDs of the SC300

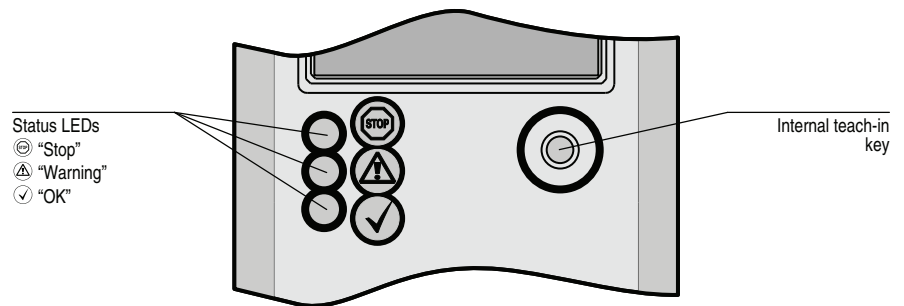

Figure 7 - Status LEDs of the SC300

Display	Color	Meaning
	Red	OSSDs shut down (e.g. if object in protective field or "lock-out")
	Green	OSSDs activated. Protective field unoccupied
	Yellow	No valid configuration taught-in (default delivery status) Perform the teach-in procedure (see "Teach-In" on page 42).
		Even flashing: reset required Press the reset button.
		Warning Carry out a fault diagnosis (see "Fault Diagnosis" on page 47).
		Error Carry out a fault diagnosis (see see "Fault Diagnosis" on page 47).

Table 3 - Meaning of the status LEDs of the SC300

Diagnostics LEDs of the SC300

The camera indicates diagnostic information with the aid of four LEDs.

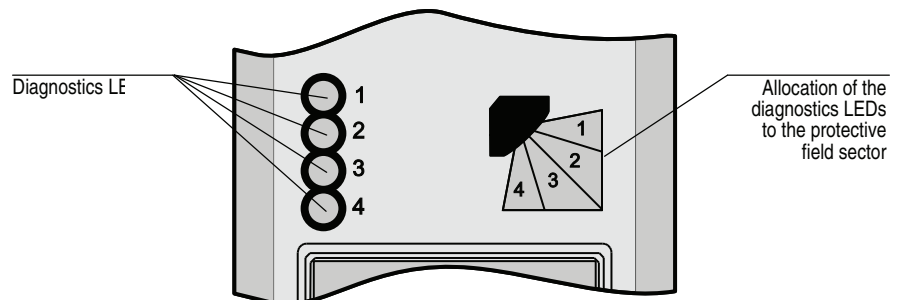

Figure 8 - Diagnostics LEDs of the SC300







Display	Meaning
	Power-up sequence: After switching on the SC300 and after each teach-in, the power up sequence runs. Starting with the diagnostics LED 1, the next diagnostics LED illuminates after one second and so on until all 4 diagnostics LEDs are illuminated.
	Protective field sector free
	Interruption of the protective field in the allocated protective field sector (see Figure 8). A protective field sector represents one quarter of the field of view of the SC300.
	Teach-in mode (see "Teach-In" on page 42).
	Warning (see "Fault Diagnosis" on page 47).
	Error (see "Fault Diagnosis" on page 47).

Table 4 - Meaning of the diagnostics LEDs

Chapter 4

Mounting

This chapter describes the preparation and completion of the mounting of the SC300 safety camera system. Mounting requires the following steps:

- Checking the dimensions of the protective field (see below)
- Determining the safety distance (see page 18)
- Mounting of the camera (see page 22)
- Mounting the reflective tape (see page 26)

The following steps are necessary after mounting:

- Completing the electrical connections (see Chapter 5 on page 29)
- Testing the installation (see “Test Notes” section on page 40)

Checking the dimensions of the protective field

ATTENTION



Only use the SC300 safety sensor system if the ratio allowed for the lengths of the sides of the protective field can be met.

If the maximum ratio of the lengths of the sides is exceeded, the safety sensor system may not operate correctly. This would mean that the operator is at risk.

Note Applicable to all resolutions:

- The ratio of the lengths of the sides of a protective field monitored must not exceed 2:1.
- If you require a larger protective field than is possible with a single SC300, you can mount two SC300 in parallel in opposite directions. In this way you can generate two overlapping protective fields (see “Application with two SC300” on page 37).

Protective field dimensions allowed at a resolution of 20 mm

The lengths of the sides of a protective field monitored must not be shorter than 0.40 m and not longer than 1.00 m.

Shorter side of the protective field	Longer side of the protective field	
	Minimum	Maximum
≥0.40 m ... <0.50 m	= shorter side	2 × shorter side
≥0.50 m ... ≤1.00 m	= shorter side	1.00 m

Table 5 - Protective field dimensions allowed for a rectangular protective field at a resolution of 20 mm (intermediate values are allowed)

Example 1: The shorter side is 0.43 m long. Then the longer side must be at least 0.43 m and is allowed to be a maximum of $2 \times 0.43 \text{ m} = 0.86 \text{ m}$ long.

Example 2: The shorter side is 0.78 m long. Then the longer side must be at least 0.78 m and is allowed to be a maximum of 1.00 m long.

Protective field dimensions allowed at a resolution of 24 mm

The lengths of the sides of a protective field monitored must not be shorter than 0.40 m and not longer than 1.20 m.

Shorter side of the protective field	Longer side of the protective field	
	Minimum	Maximum
≥0.40 m ... <0.60 m	= shorter side	2 × shorter side
≥0.60 m ... ≤1.20 m	= shorter side	1.20 m

Table 6 - Protective field dimensions allowed for a rectangular protective field at a resolution of 24 mm (intermediate values are allowed)

Example 1: The shorter side is 0.43 m long. Then the longer side must be at least 0.43 m and is allowed to be a maximum of 2 × 0.43 m = 0.86 m long.

Example 2: The shorter side is 0.78 m long. Then the longer side must be at least 0.78 m and is allowed to be a maximum of 1.20 m long.

Protective field dimensions allowed at a resolution of 30 mm

The lengths of the sides of a protective field monitored must not be shorter than 0.60 m and not longer than 1.50 m.

Shorter side of the protective field	Longer side of the protective field	
	Minimum	Maximum
≥0.60 m ... <0.75 m	= shorter side	2 × shorter side
≥0.75 m ... ≤1.50 m	= shorter side	1.50 m

Table 7 - Protective field dimensions allowed for a rectangular protective field at a resolution of 30 mm (intermediate values are allowed)

Example 1: The shorter side is 0.63 m long. Then the longer side must be at least 0.63 m and is allowed to be a maximum of 2 × 0.63 m = 1.26 m long.

Example 2: The shorter side is 0.78 m long. Then the longer side must be at least 0.78 m and is allowed to be a maximum of 1.50 m long.

Determining the safety distance

The safety camera system must be mounted with an adequate safety distance between the protective field and the hazardous point. This safety distance helps provide that the hazardous point can only be reached after the dangerous state of the machine has been completely stopped.

	<p>ATTENTION No protective function without sufficient safety distance. The reliable protective effect of the safety sensor system depends on the safety sensor system being mounted with the correct safety distance from the hazardous point.</p>
---	--

Note If mounted vertically, the protective field is from the centre of the camera lens to the edge of the reflective tape that is closest to the hazardous point. (The reference point for the safety distance S is therefore not the middle of the reflective tape (see Figure 9).)

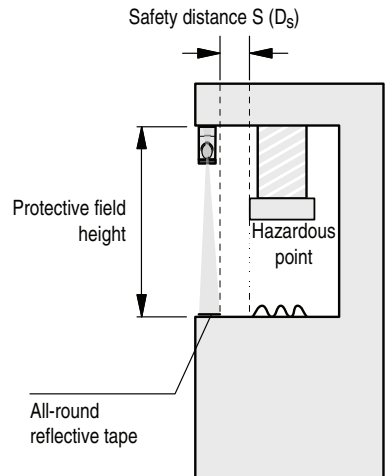

Figure 9 - Safety distance from the hazardous point

ATTENTION



If the protective field is at an angle, pay special attention to the safety distance.

Ensure the necessary safety distance between the access point and the hazardous point is met at all parts of the protective field at an angle.

- Note that different rules may apply to the calculation of the safety distance for protective fields at an angle.
- Your Rockwell Automation distributor/sales office will be pleased to assist you with the implementation of special applications.

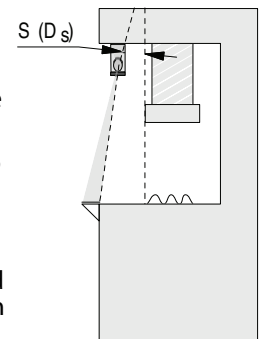

Safety distance according to prEN ISO 13 855 and EN ISO 13 857

The safety distance as defined in prEN ISO 13 855 and EN ISO 13 857 depends on:

- Stopping/run-down time of the machine or system (The stopping/run-down time is shown in the machine documentation or must be determined by taking a measurement.)
- Response time of the entire protective device (SC300: 20 ms)
- Reach or approach speed
- Other parameters that are stipulated by the standard depending on the application

How to calculate the minimum safety distance S according to prEN ISO 13 855 and EN ISO 13 857:

Note The following calculation shows an example calculation of the safety distance. The calculation is based on the assumption that the approach is perpendicular to the protective field.

Depending on the application and the ambient conditions, a different calculation may be necessary.

- Initial formula: $S = K \times T + 8 \times (d - 14)$

Where ...

S = Safety distance in [mm]

K = 2000 mm/s

Definition and value as per prEN ISO 13 855, derived from data on the approach speed of the body or parts of the body

T = Stopping/run-down time of the entire system in [s]

Stopping/run-down time of the entire system = Stopping/run-down time of the machine + response time of the protective device after light path interruption

d = Detection capability (resolution) of the protective device in [mm]

The reach/approach speed is already included in the calculation formula.

With K = 2000 mm/s the 1st formula is:

1. calculation formula: $S = 2000 \times T + 8 \times (d - 14)$

- If the result S is ≥ 100 mm and $S \leq 500$ mm, then use the determined value as the safety distance.

Note As per prEN ISO 13 855 a safety distance $S < 100$ mm is not allowed. If you obtain a value $S < 100$ mm with your calculation, please contact Rockwell Automation.

- If the result is $S > 500$ mm, use $K = 1600$ mm/s in the formula and calculate S again:

2. calculation formula: $S = 1600 \times T + 8 \times (d - 14)$

- If the new value S is > 500 mm, then use the newly determined value as the minimum safety distance.

If the new value S is ≤ 500 mm, then use 500 mm as the minimum safety distance.

Example:

The following values apply:

Stopping/run-down time of the machine = 290 ms

Response time of the SC300 after light path interruption = 20 ms

Detection capability (resolution) d of the SC300 = 20 mm

Note You will find the values for the response time and the resolution of the SC300 in “Technical specifications” on page 49.

Minimum safety distance calculation:

- Step 1: Calculation of the stopping/run-down time of the entire system:
 $T = 290 \text{ ms} + 20 \text{ ms} = 310 \text{ ms} = 0.31 \text{ s}$
- Step 2: Insert the values in the 1st formula ($S = 2000 \times T + 8 \times (d - 14)$):
 $S = 2000 \times 0.31 + 8 \times (20 - 14) = 668 \text{ mm}$
- Step 3: Check the value for S.
 $S > 500$ mm. For this reason the 2nd formula must be used.
- Step 4: Insert the values in the 2nd formula ($S = 1600 \times T + 8 \times (d - 14)$):
 $S = 1600 \times 0.31 + 8 \times (20 - 14) = 544 \text{ mm}$

- Step 5: Check the value of S .
 $S > 500$ mm. For this reason 544 mm must be used as the minimum safety distance.

Safety distance if OSHA and ANSI are applicable

If OSHA and ANSI are applicable, the safety distance depends on:

- Stopping/run-down time of the machine or system
(The stopping/run-down time is shown in the machine documentation or must be determined by taking a measurement.)
- Response time of the entire protective device (SC300: 20 ms)
- Reach or approach speed
- Other parameters that are stipulated by the standard depending on the application

How to calculate the safety distance D_s if OSHA and ANSI are applicable:

Note The following calculation shows an example calculation of the safety distance. Depending on the application and the ambient conditions, a different calculation may be necessary.

- Calculate D_s using the following formula:

$$D_s = H_s \times (T_s + T_c + T_r + T_{bm}) + D_{pf}$$

Where ...

D_s = The minimum distance in inches (or millimetres) from the hazardous point to the protective device

H_s = A parameter in inches/second or millimetres/second, derived from data on approach speeds of the body or parts of the body. Often 63 inches/second (1600 mm/second) is used for H_s .

T_s = Stopping/run down time of the machine tool measured at the final control element

T_c = Stopping/run-down time of the control system

T_r = Response time of the entire protective device after light path interruption (SC300: 20 ms)

T_{bm} = Additional response time allowed for brake monitor to compensate for wear

Note Any additional response times must be accounted for in this calculation.

D_{pf} = An additional distance added to the overall safety distance required. This value is based on intrusion toward the hazardous point prior to actuation of the electro-sensitive protective equipment (ESPE). Values range from 0.25 inches to 48 inches (6 to 1220 millimetres) or more depending on application.

Example:

For vertical protection with an opto-electronic protective device with an effective resolution finer than 2.5 inches (64 millimetres), D_{pf} can be determined approximately using the following formula:

D_{pf} (inches) = $3.4 \times (\text{effective resolution} - 0.276)$, but not less than 0.

Avoiding unmonitored areas

ATTENTION



Provide separate protection for unmonitored areas.
 During the installation of the SC300 safety sensor system, incorrect mounting or mutual interference between several systems may result in areas that are not monitored and through which an operator could reach the hazardous point.

- Protect unmonitored areas using mechanical guards.
- Note the following warning and precautions to prevent unmonitored areas.

ATTENTION



Avoid mounting in a frame.
 In the case if mounting in a frame, due to the principle of operation unmonitored areas will be produced through which an operator could reach the hazardous point.

- Mount the safety sensor on the frame instead of in the frame to avoid unmonitored areas from the start (see "Mounting on a frame" on page 25).
- If mounting in a frame is nevertheless necessary, you must identify the unmonitored areas with the aid of the test rod and provide protection using mechanical panels.

In the case of mounting in a frame, the unmonitored area reaches from the inside of the mounting corner to the position at which the test rod is safely detected (see Figure 10).

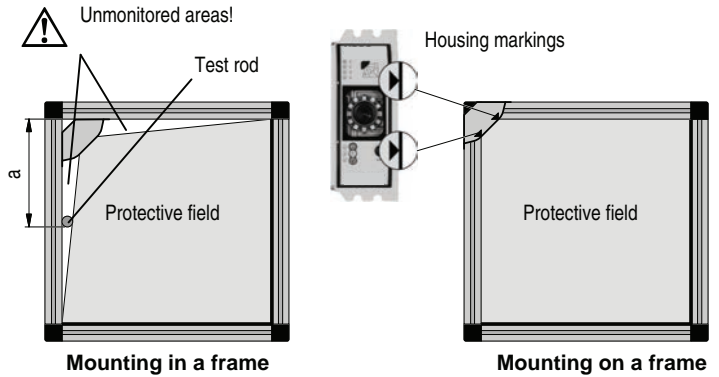

Figure 10 - Avoiding unmonitored areas due to mounting on a frame

Resolution	20 mm	24 mm	30 mm
Length <i>a</i> of the unmonitored area	>0.40 m	>0.40 m	>0.60 m

Table 8 - Length of the unmonitored area in the case of mounting in a frame

ATTENTION

During mounting, please observe the maximum protective field width.

If, during mounting, the maximum protective field width for one or two safety sensor systems is exceeded, the safety sensor will not see the reflective tape opposite. As a result an unmonitored area will be produced. The operator is at risk.

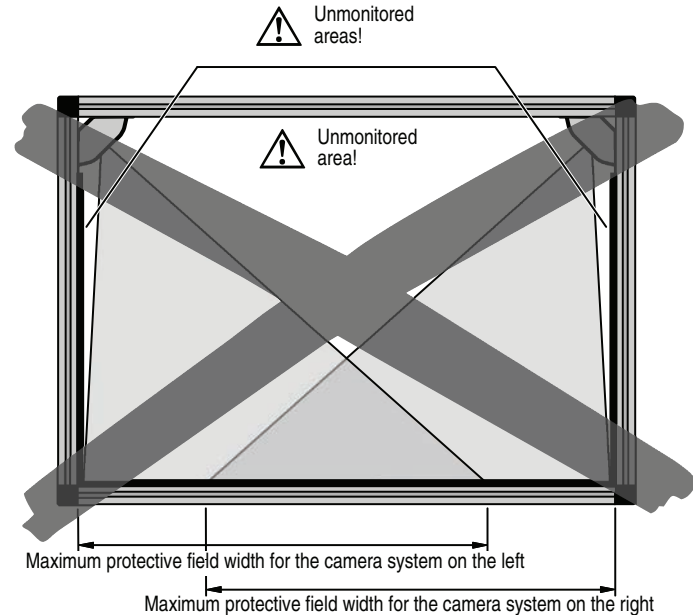

Figure 11 - Dangerous mounting mistake: maximum protective field width exceeded. The mounting shown here is expressly not recommended by Rockwell Automation.

ATTENTION

Prevent the mutual interference of systems mounted in close proximity.

If two SC300 are so arranged that they entirely or partially look at the same reflective tape, the two safety sensors may interfere with each other. This can disrupt the protective function of the system. This would mean that the operator is at risk.

➤ Take suitable measures to prevent mutual interference:

- If the two safety sensors are used in different applications:
 - Reverse the direction in which one of the systems looks.
 - Choose a different mounting method (see “Steps for mounting the safety sensor system” section on page 24).
 - Mount non-reflective field of view guards.
- If the two safety sensors are used in the same application, then synchronize the two systems (see “Two SC300 with synchronization” section on page 32).

Steps for mounting the safety camera system

ATTENTION



Special features to note during mounting:

- Avoid unmonitored areas as described in the previous section.
- Always mount the safety sensor on a flat surface.
- Always mount the safety sensor on a metal surface and ensure good mechanical contact for adequate heat dissipation from the device.
- During mounting, ensure that safety sensor and reflective tape are aligned correctly. The SC300 accepts a defined lateral tolerance (see "Mounting the reflective tape" on page 26).
- Take suitable measures to attenuate vibration if the shock requirements are above the values given in the "Data sheet" section on page 49.
- Observe the safety distance of the system during mounting. On this subject read "Determining the safety distance" on page 18.
- Mount the safety sensor system such that it is not possible reaching under, reaching over or standing behind the sensor and that the sensor cannot be repositioned.

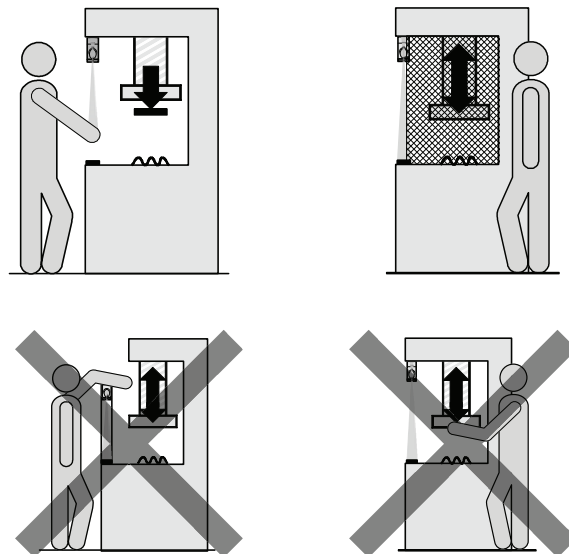

Figure 12 - The correct installation (above) must eliminate the errors (below) reaching over, reaching under and standing behind.

- Secure the two fixing screws against unintentional loosening.
- Once the system is mounted, one or several of the enclosed self-adhesive safety information labels must be affixed:
 - Use only information labels in the language which the operators of the machine understand.
 - Affix the information labels such that they are easily visible by the operators during operation. After attaching additional objects and equipment, the information labels must not be concealed from view.
 - Affix the information label "Important Information" to the system in close proximity to the safety sensor system.

The most common mounting options are:

- Mounting on a frame
- Mounting in a frame

Note You will find other mounting options on the example application at www.rockwellautomation.com.

Mounting on a frame

Notes

- Always mount the camera with at least two screws and use the fastening openings on two opposite sides of the housing.
- Secure the two mounting screws against unintentional loosening.
- Always use washers under the screws (Figure 13)
- To mount the camera use sliding nuts suitable for the profile system used or the clamping lugs available as accessories (see “Accessories” section on page 55).
- Pay attention to the thickness of the flange on the camera when selecting a suitable screw length (see “Dimensional drawings” section on page 52).

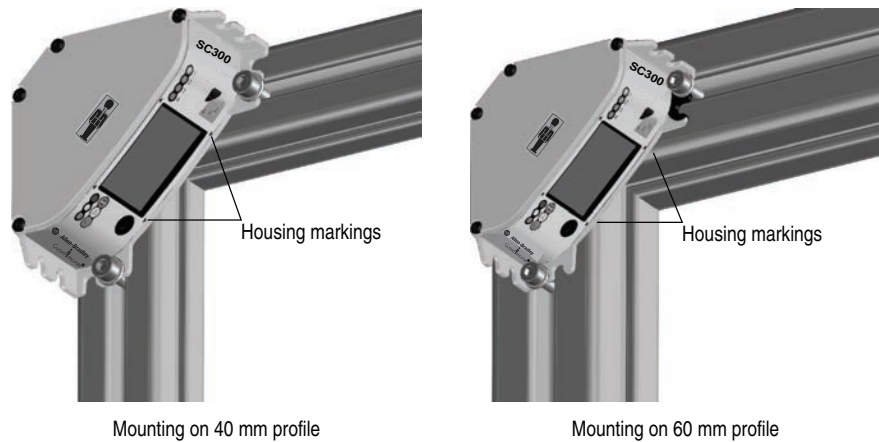

Figure 13 - Example: mounting with sliding nuts on different thickness profiles

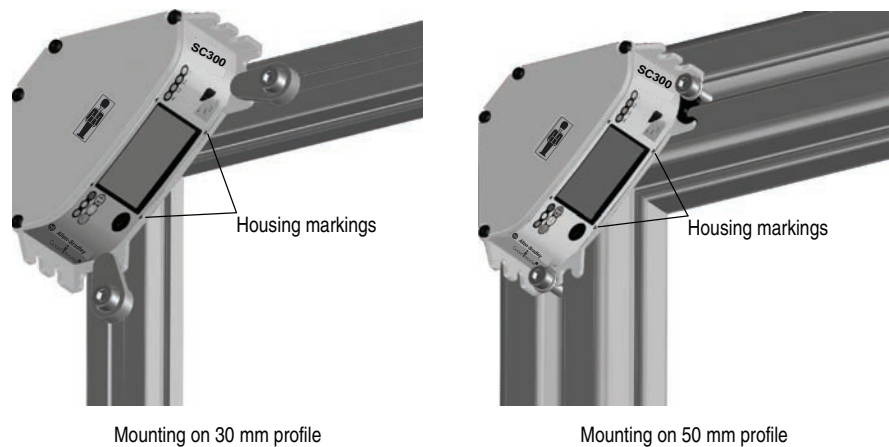

Figure 14 - Example: mounting with clamping lugs on different thickness profiles

- Align the camera such that the housing markings are aligned with the inside of the frame profile. (The protective field stretches between the housing markings and the ends of the reflective tape.)

Mounting in a frame



Figure 15 - Mounting in a frame

Notes

- Always mount the camera with at least two screws and use the fastening openings on two opposite sides of the housing.
- Secure the two fixing screws against unintentional loosening.
- Always use washers under the screws (Figure 15).
- Use sliding nuts suitable for the profile system employed for mounting the camera.
- Pay attention to the thickness of the flange on the camera when selecting a suitable screw length (see “Dimensional drawings” section on page 52).



ATTENTION

Protect unmonitored areas using mechanical guards!

- Take organizational measures to protect the un-monitored areas (see page 22).

Mounting the reflective tape

Prior to mounting the reflective tape, pay attention to the following notes:

Notes

- Plan the attachment of the reflective tape exactly prior to bonding it in place. The adhesive on the reflective tape is very resilient. It is not possible to remove the tape again without destroying it. You will need a suitable solvent to remove the reflective tape (see “Accessories” section on page 55).
- If you must bond the reflective tape in several sections, then ensure there are no gaps, folds or offset at the joints. The reflective tape must run seamlessly along the contour to be monitored.

Only the longest contiguous section of the reflective tape is taught-in by the SC300. If there are gaps in the reflection, the safety camera system will ignore the shorter section of the reflective tape.

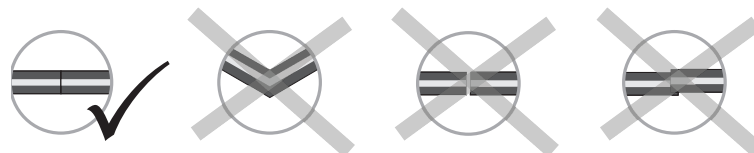

Figure 16 - Correct arrangement of the reflective tapes at joints

- If damage to the reflective tape is to be expected due to the application, e.g. because heavy or sharp-edged objects are pushed over the working area, you should use one of the following possible mounting methods:
 - Mount the camera in the bottom of the frame.
 - Mount the camera lower than the contact surface in front of the frame.

How to mount the reflective tape:

The reflective tape is attached by simply bonding it in place.

- Clean the surface where the tape is to be attached so that it is clean of residue.
- Remove the protective film on the rear of the reflective tape and apply the tape perpendicular to the camera's optical axis. The camera will tolerate a small divergence from the optical axis (Figure 17).

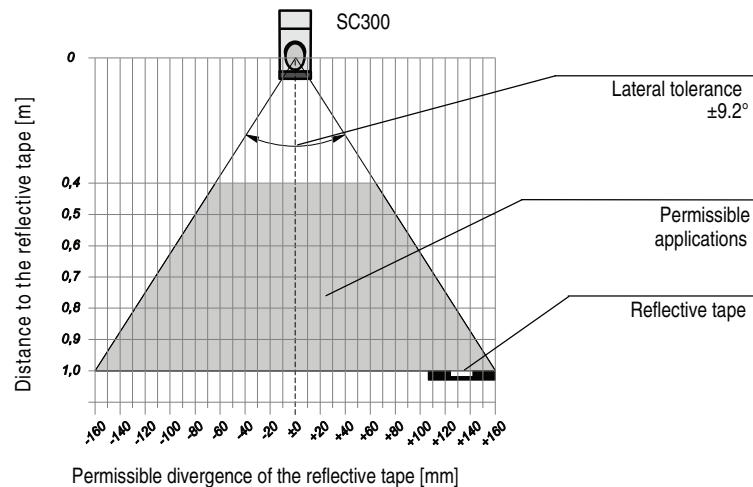

Figure 17 - Permissible divergence of the reflective tape from the optical axis of the camera as a function of the distance at 20 mm resolution (illustration of divergence not to scale)

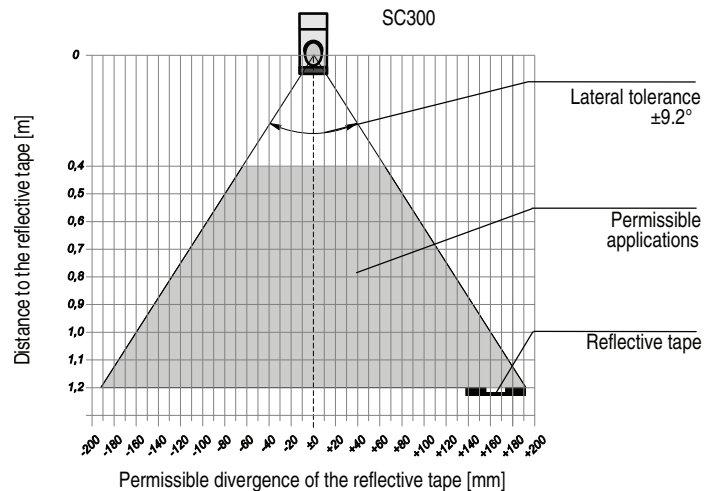

Figure 18 - Permissible divergence of the reflective tape from the optical axis of the camera as a function of the distance at 24 mm resolution (illustration of divergence not to scale)

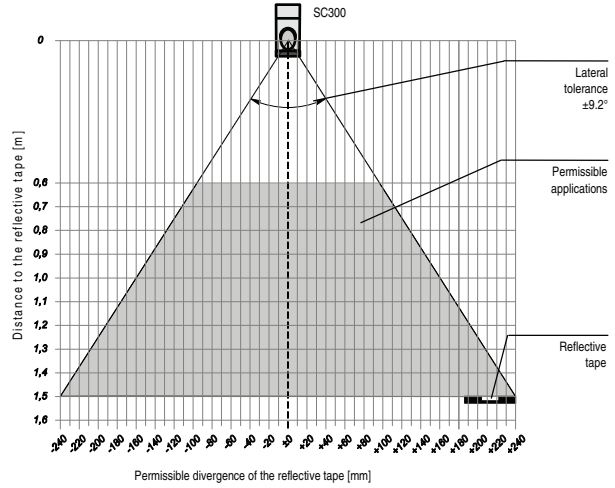

Figure 19 - Permissible divergence of the reflective tape from the optical axis of the camera as a function of the distance at 30 mm resolution (illustration of divergence not to scale)

- Press the reflective tape firmly and ensure the edges are firmly sealed. In this way you will guard against dirt and liquids getting under the reflective tape.

Chapter 5

Electrical Installation

ATTENTION



Switch the entire machine/system off line.

The machine/system could unintentionally start up while you are connecting the devices.

- Ensure that the entire machine/system is disconnected during the electrical installation.

Connect OSSD1 and OSSD2 separately.

You are not allowed to connect OSSD1 and OSSD2 together, otherwise signal safety will not be ensured.

- Ensure that the machine controller processes the two signals separately.
- Contactors connected in series must be positively guided and monitored (see “External device monitoring (EDM)” on page 44).

Only connect the OSSDs to a single subsequent switching element.

- Each output signal switching device (OSSD) is only allowed to be connected to one switching element (e.g. relay or contactor). If several switching elements are required, then you must choose a suitable form of contact duplication.

Prevent the occurrence of a potential difference between the loads and the protective device.

- If you connect loads to the OSSDs that are not reverse polarity protected, then you must connect the 0V connections for these loads and the related protective device separately, one after the other, to the same 0V terminal strip. Only then is it ensured that in the case of a fault, it is not possible for a potential difference to form between the 0V connections for the loads and the related protective device.

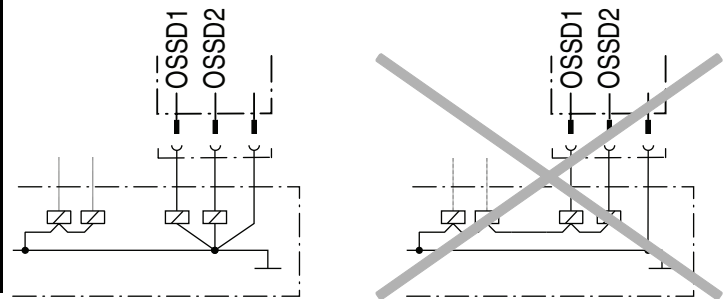

- Notes**
- The two outputs are protected against short-circuits to 24V DC and 0V. When the light path is clear, the signal level on the outputs is HIGH DC (at potential), when the light path is interrupted or there is a device fault the outputs are LOW DC.
 - The SC300 safety camera system meets the interference suppression requirements (EMC) for industrial use (interference suppression class A). When used in residential areas it can cause radio interferences.

- To achieve full electromagnetic compatibility (EMC), functional earth (FE) must be connected.
- To meet the requirements of the relevant product standards (e.g. EN 61 496-1), the external voltage supply for the devices (SELV) must be able to bridge a brief mains failure of 20 ms. Power supplies according to EN 60 204-1 satisfy this requirement. Suitable power supplies are available as accessories from Rockwell Automation (see “Accessories” section on page 55).

System connection M12 × 8

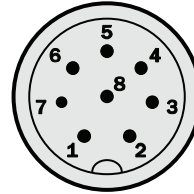

Figure 20 - System connection SC300

The SC300 has a hard-wired connector cable (length: approx. 30 cm) with a cable plug M12 × 8.

Pin	Color	Signal	Function
1	White	RESTART	Reset/restart (optional)
2	Brown	+24V DC	24V DC (voltage supply)
3	Green	TEACH/SYNC	Teach-in/synchronization
4	Yellow	EDM	External device monitoring (EDM) (optional)
5	Grey	OSSD1	OSSD1 (safe output signal switching device 1)
6	Pink	OSSD2	OSSD2 (safe output signal switching device 2)
7	Blue	GND	0V DC (voltage supply)
8	–	FE	Functional earth

Table 9 - Pin assignment system connection SC300

Note Connecting cables of different length are available as accessories from Rockwell Automation (see “Accessories” section on page 55). If you use connecting cables you have assembled yourself, ensure the functional earth (pin 8) is connected.

Connecting the SC300

Without external device monitoring (EDM), without internal restart interlock and without external key-operated pushbutton for teach-in

Note If you use the SC300 without the internal restart interlock, then you must implement the restart interlock externally, i.e. machine-side.

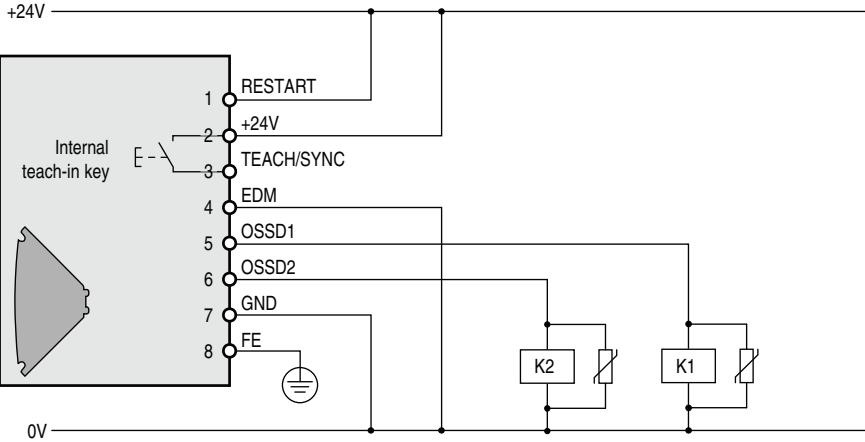

Figure 21 - Connecting the SC300 without external device monitoring (EDM), without internal restart interlock and without external key-operated pushbutton for teach-in

With external device monitoring (EDM), with internal restart interlock and with external key-operated pushbutton for teach-in

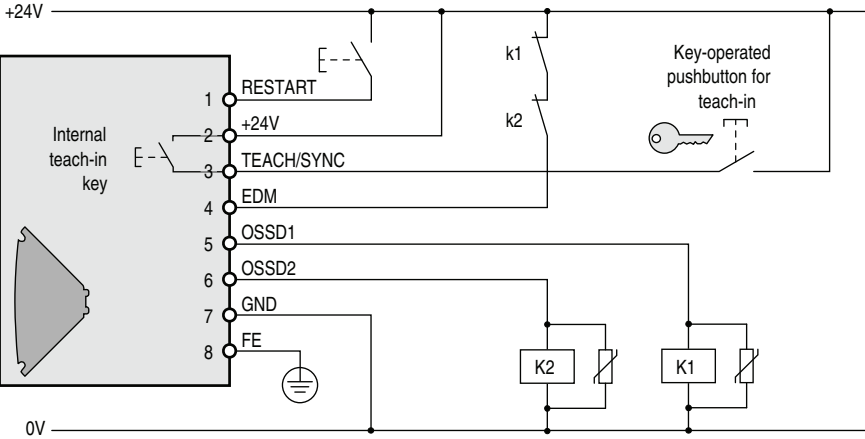

Figure 22 - Connecting the SC300 with external device monitoring (EDM), with internal restart interlock and with external key-operated pushbutton for teach-in

Reset button/restart

When using the SC300 with internal restart interlock (see the “Restart interlock” section on page 13), the operator must press the reset button prior to restart.



ATTENTION Select the correct installation site for the reset button. Install the reset button outside the hazardous area such that it cannot be operated from inside the hazardous area. When operating the reset button, the operator must have full visual command of the hazardous area. Perform a teach-in procedure after any change to the connection. The SC300 activates the internal restart interlock only after the next teach-in procedure. Otherwise the system will not switch to green.

The configuration of the internal restart interlock is described on page 13.

External device monitoring (EDM)

You must implement the external device monitoring electrically as follows: When the contact elements (K1, K2) reach their de-energized position after the protective device has responded, the two positively guided N/C contacts (k1, k2) must close. 24V is then applied at the input of the EDM. If 24V is not present after the response of the protective device, then one of the contact elements is faulty and the external device monitoring prevents the machine starting up again.

<p>ATTENTION</p> 	<p>Perform a teach-in procedure after any change to the connection.</p> <p>The SC300 activates the external device monitoring only after the next teach-in procedure. If you place the system in operation after connecting the contacts to the <i>external device monitoring (EDM)</i> input without teach-in, then the external device monitoring will remain deactivated. The system can therefore switch to green despite faulty contactors.</p>
---	--

The configuration of the external device monitoring is described on page 44.

External key-operated pushbutton for teach-in

To permit remote teach-in and/or to protect the configuration, you can connect an external key-operated pushbutton for teach-in and lock the internal teach-in key.

- Notes**
- Once the key-operated pushbutton for teach-in has been operated, the SC300 locks the internal teach-in key and saves this configuration in the device. Teach-in can only be performed using the external key-operated pushbutton for teach-in (see “Locking the internal teach-in key” on page 45).
 - If you use two SC300 in an application, then both systems use the same external key-operated pushbutton for teach-in (see Figure 23).

Two SC300 with synchronization

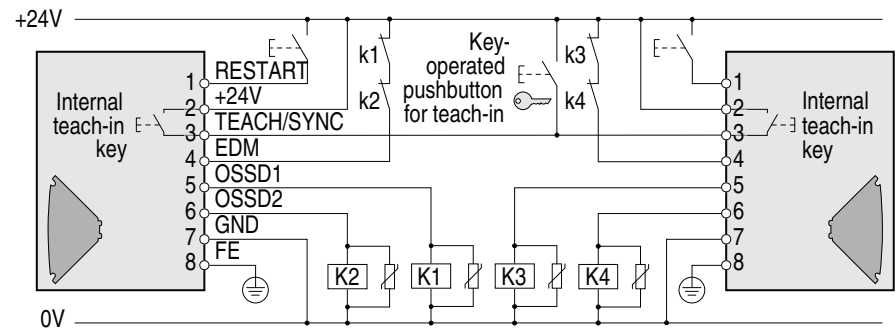

Figure 23 - Connection of two SC300 with synchronization

If two SC300 are so arranged that they entirely or partially look at the same reflective tape, the two cameras may interfere with each other. To guard against this situation occurring, you must synchronize the two cameras.

How to synchronize two SC300:

- Connect pin 3 on the two cameras together. The cameras will synchronize automatically each time after switch on and after every teach-in procedure.

- Notes**
- If you actuate the external key-operated pushbutton for teach-in or one of the two internal teach-in keys, both devices will learn their protective fields at the same time.

- If you use the internal restart interlock, then you can connect separate reset buttons or a common reset button for both cameras.
- If you use the external device monitoring, then must connect separate normally closed contacts (k1, k2) for both cameras.

Connection diagrams

- Notes**
- Take note of the related operating instructions of the integrated devices!
 - You can find more connection diagrams at www.rockwellautomation.com.

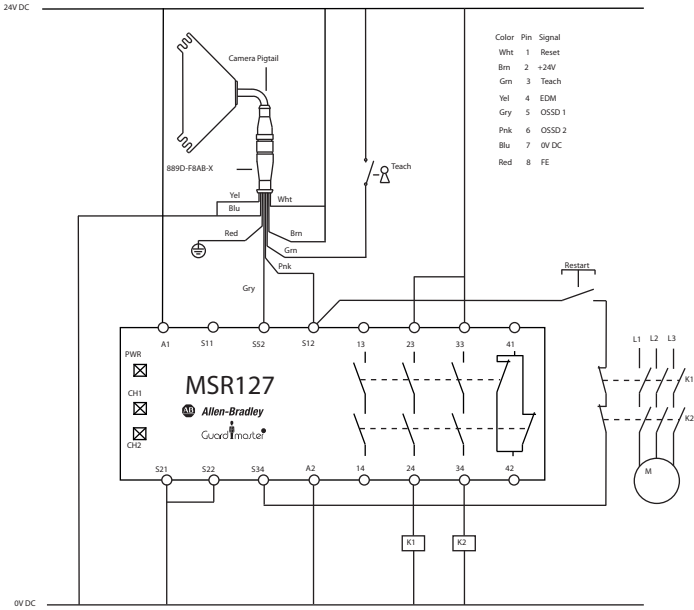

Figure 24 - SC300 safety camera configured with external teach connected to an MSR127RP wired for monitored manual restart

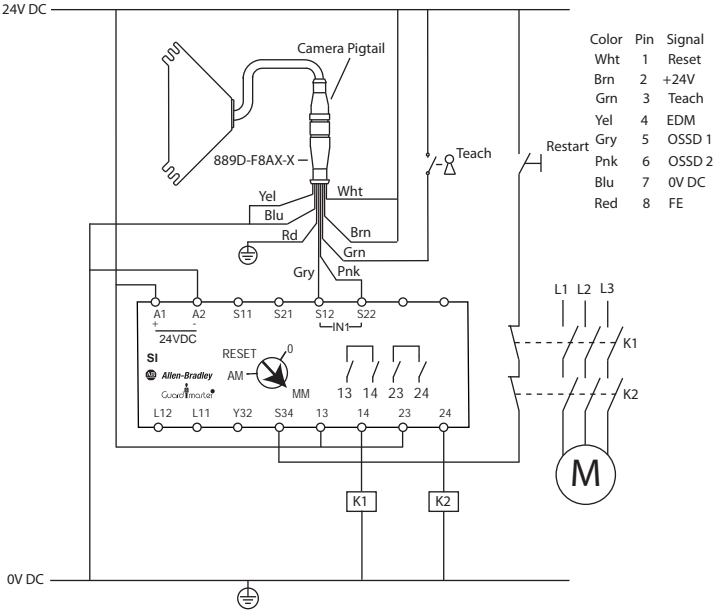

Figure 25 - SC300 safety camera with external teach connected to a GSR SI safety relay module configured for monitored manual restart

Principle of operation (Figure 24 and 25)

The only difference between Figure 24 and 25 are the safety relay modules are different. The figures are both wired for the same overall functionality.

When the light path on the SC300 is clear and the input conditions on the MSR127 or GSR SI are valid, the system is ready for switch on and waits for an input signal/switch on signal. The system's corresponding logic path is enabled by pressing and releasing the related restart button. The related output on the MSR127 or GSR SI carry power. If the input conditions are no longer met, then the related outputs on the MSR127 or GSR SI shut down.

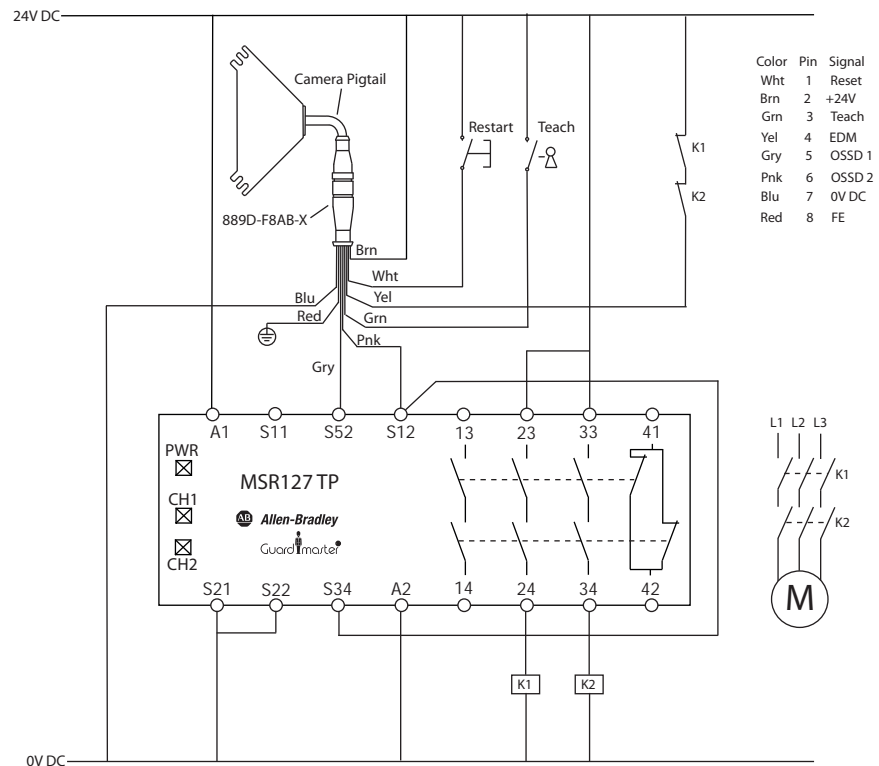

Figure 26 - SC300 safety camera configured for manual restart, EDM and external teach connected to an MSR127TP safety relay module with automatic restart

Principle of operation

When the light path on the SC300 safety camera is clear and the input conditions on the MSR127TP are valid, the system is ready for switch on and waits for an input signal/switch on signal. The system's corresponding logic path is enabled by pressing and releasing the related restart switch. The related outputs of the MSR127TP carry power. If the input conditions are no longer met, the related outputs of the MSR127TP open interrupting the power.

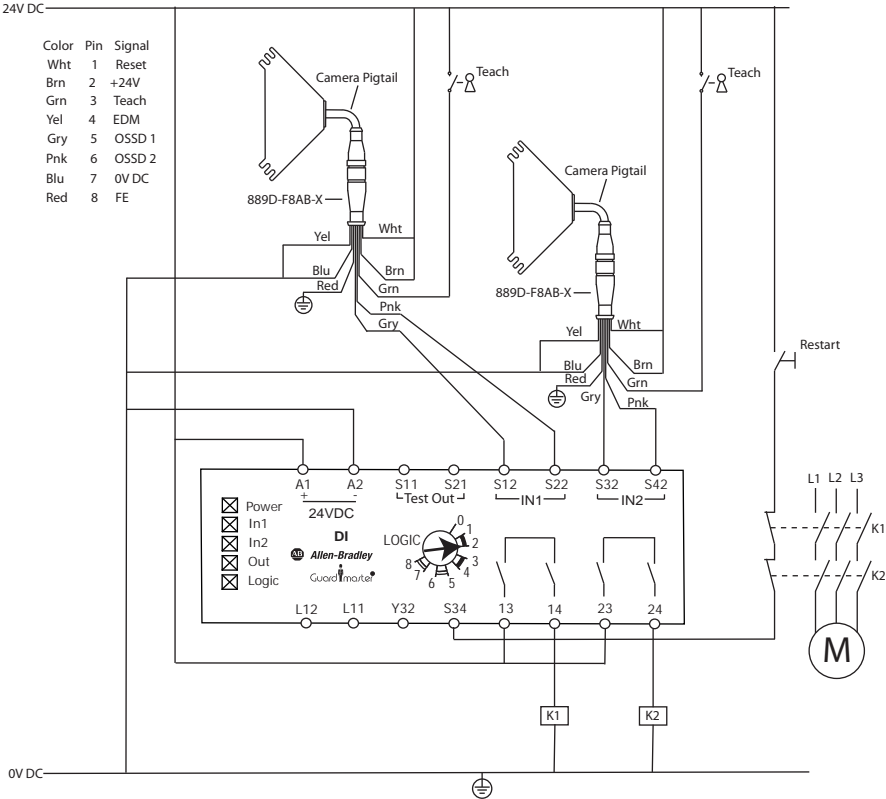

Figure 27 - Two SC300 safety cameras with external teach connected to a GSR DI safety relay module with configured for monitored manual restart

Principle of operation

When the light path on both SC300 safety cameras are clear and the input conditions on the GSR DI safety relay modules are valid, the system is ready for switch on and waits for an input signal/switch on signal. The system’s corresponding logic path is enabled by pressing and releasing the related restart switch. The related outputs of the GSR DI carry power. If the input conditions are no longer met, the related outputs of the GSR DI shut down.

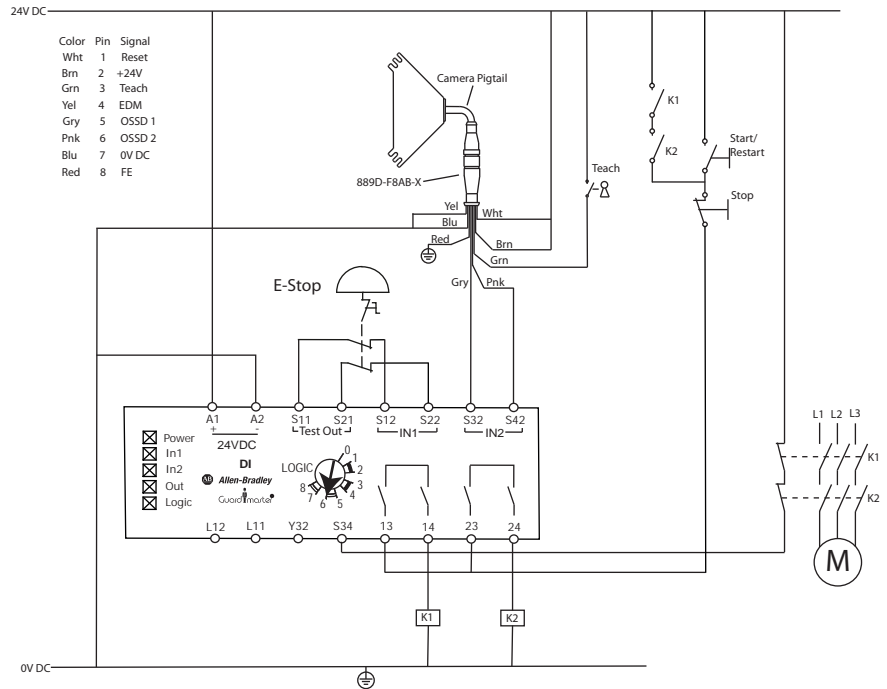

Figure 28 - SC300 safety camera configured for automatic restart with external teach connected to a GSR DI safety relay module configured for automatic restart and also showing an E-Stop switch connection.

Principle of operation

When the light path on the SC300 safety camera is clear and the input conditions on the GSR DI safety relay module are valid, the system is ready for switch on and waits for an input signal/switch on signal. The system’s corresponding logic path is enabled by pressing and releasing the related restart switch. The related outputs of the GSR DI carry power. If the input conditions are no longer met, the related outputs of the GSR DI shut down.

The restart switch/button must be used to restart the system.

Chapter 6

Application Examples

Note The examples shown are only provided as an aid for your planning. You may need to consider additional protection measures for your application.

Application with one SC300

If the necessary protective field dimensions can be realized using a single SC300, then mount the camera on a corner of the frame or in a corner of the frame. Apply the reflective tape to the opposite sides.

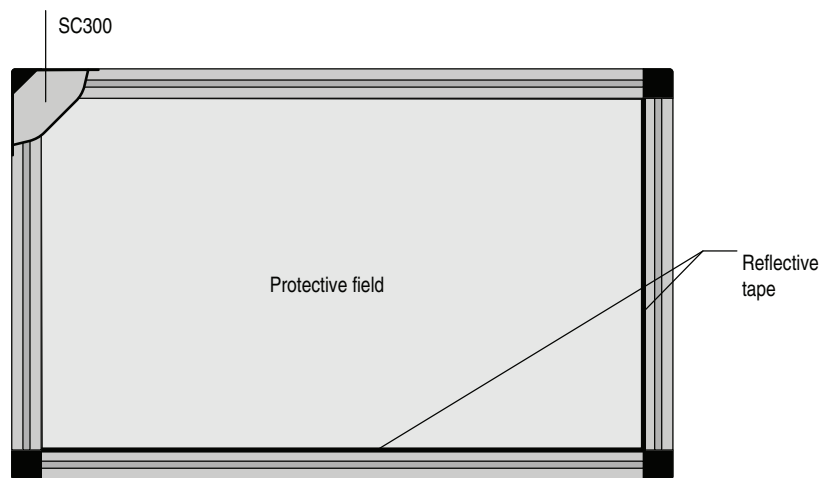

Figure 29 - Application with small protective field (1 × SC300)

Application with two SC300

If the application requires a larger protective field width that can be covered with one SC300, or the hazardous point is to be protected in an ergonomic manner, you can mount two SC300 in parallel in opposite directions (see Figure 27) or at the corners (see Figure 28). In this way you can realize two overlapping protective fields.

Notes

- Mount the devices overlapping as shown in the figure (i.e. not back to back). Otherwise un-monitored areas may be produced.
- Ensure the housing markings on the two cameras are aligned.
- You must synchronize the two SC300 with each other so that they do not interfere with each other (see page 32).

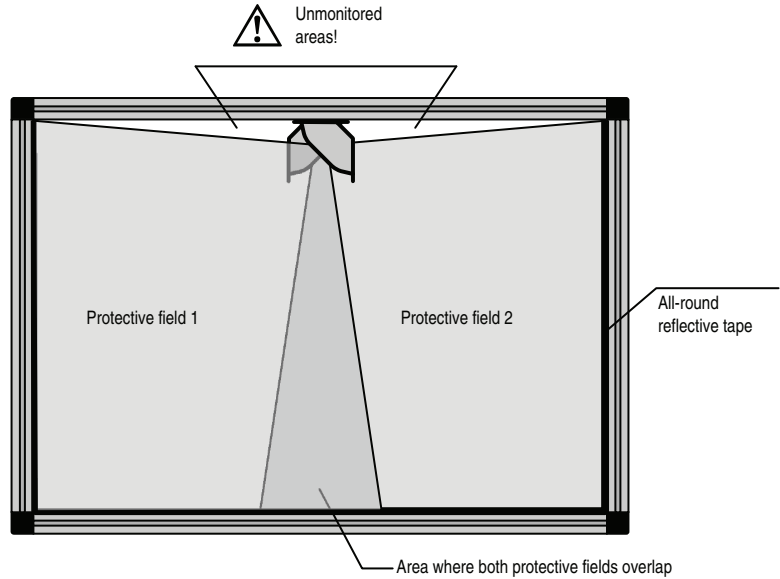

Figure 30 - Application with large protective field (2 x SC300)

Application with safe access on three sides (ergonomic workplace design)

To realize an equally ergonomic and effective workplace, you can mount two safety camera systems diagonally. In this way the hazardous point can be safely accessed from three sides.

Note Due to the diagonal arrangement of the protective fields and the necessary safety distance, the working distance for the operator may be larger in this application.

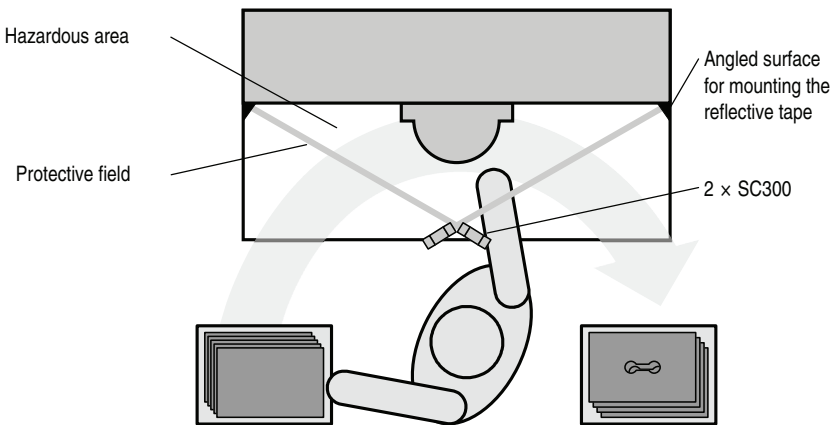

Figure 31 - Ergonomic workplace design due to the use of two SC300 (view from above)

Notes

- In this application pay special attention to the correct mounting of the reflective tapes as shown in the diagram. The reflective tapes must always be perpendicular to the protective field area.
- In this application the monitored area is mostly smaller than the working area available. For this reason mark the contour of the monitored area on the working area if this marking is not already provided by the reflective tape.

Application with automatic material transport to the workstation

If the application requires automatic material transport into the workstation, you can mount the safety camera system such that only the area above the material transport is monitored.

ATTENTION



Protect the material transport using other measures.

The SC300 does not monitor the material transportation with this mounting method.

- Protect the unmonitored areas on both sides of the material transport using mechanical guards.
- Prevent people from being able to reach through the material transport to the hazardous point using organizational measures (e.g. by increasing the safety distance).

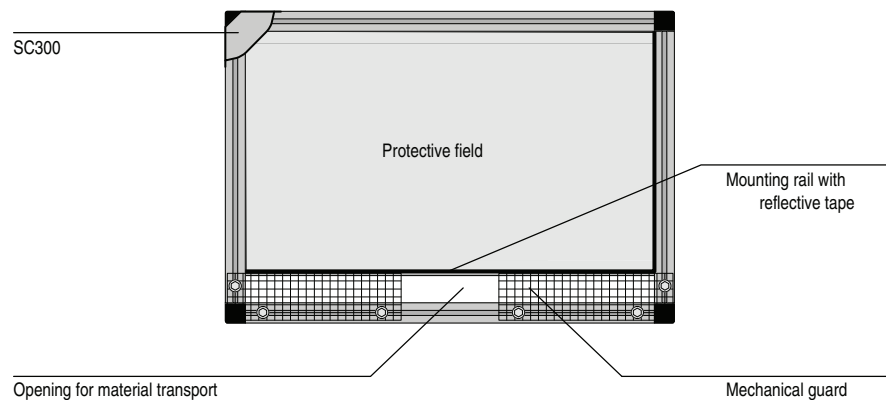

Figure 32 - Mounting with automatic material transport into the workstation

Commissioning

ATTENTION

Commissioning requires a thorough check by qualified safety personnel.

Before you operate a system protected by the SC300 safety sensor system for the first time, make sure that the system is first checked and released by qualified safety personnel. Please read the notes in the “On safety” chapter on page 8.

Test notes

The purpose of the tests described in the following is to confirm the safety requirements specified in the national/international rules and regulations, especially the safety requirements in the Machine and Work Equipment Directive (EU Conformity).

These tests are also used to identify if the protection is affected by external light sources or other unusual ambient effects.

These tests must therefore always be performed.

Pre-commissioning tests

- Check the effectiveness of the protective device mounted to the machine, using all selectable operating modes as specified in the checklist in the annex (see “Checklist for the manufacturer” on page 56).
- Ensure that the operating personnel of the machine protected by the safety camera system are correctly instructed by qualified safety personnel before being allowed to operate the machine. Instructing the operating personnel is the responsibility of the machine owner.

Regular inspection of the protective device by qualified safety personnel



- Check the system, following the inspection intervals specified in the national rules and regulations. This procedure helps confirm that any changes on the machine or manipulations of the protective device after the initial commissioning are detected.
- If any modifications have been made to the machine or the protective device, or if the safety camera system has been changed or repaired, the system must be checked again as specified in the checklist in the annex.

Tests of the protective device by a specialist or authorized personnel

ATTENTION



Do not operate the machine if the green or yellow LED is lit during the test. During the check only the  Red LED is allowed to illuminate.

If the  or the  LED lights up *during the test* even for a short period, work must stop at the machine. In this case the installation of the safety sensor system must be checked by qualified safety personnel.

When must the protective device be checked?

- The protective device must be checked daily by a specialist or by authorized personnel.
- The protective device must be checked each time the operator changes.

How to check the protective device:

- Check the protective device for correct seating and for damage, in particular the mounting, the electrical connection, the front screen and the reflective tape.
- Check that personnel or body parts can only intrude into the hazardous area through the protective field of the SC300 (e.g. if a mechanical guard has been removed).
- Check whether the protective device is effective for the set operating mode.
- Choose the test rod that matches the resolution used. The diameter of the test rod must correspond to the actual resolution of the system achieved by the resolution set that has been used.
- Guide the test rod slowly along the outer edge of the protective field as shown in Figure 30.

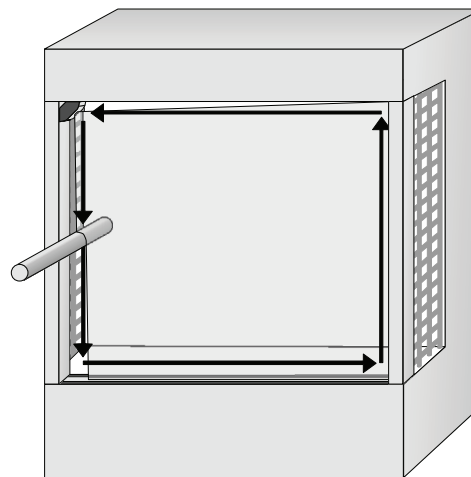

Figure 33 - Daily test of the protective device with the test rod

Configuration

ATTENTION

Ensure the machine is in a safe condition!

While you configure the safety sensor system, the machine could start unintentionally.

➤ Ensure that the whole system is in a safe condition during the configuration process.

Teach-in

Prior to initial commissioning, you must perform a new teach-in procedure. The following occurs during teach-in:

- The SC300 detects the current connection configuration and configures the internal restart interlock, the external device monitoring and the locking of the internal teach-in key to suit. In the default delivery status, these functions are deactivated.
- The SC300 detects the protective field based on the reflective tape. In the default delivery status, the SC300 has no protective field configured.

How to teach-in the current configuration and shape of the protective field:

- Ensure camera and reflective tape are correctly mounted and the electrical connections have been made.
- Switch on the SC300. The  LED is constantly illuminated.

ATTENTION

Ensure there are no objects in the protective field during teach-in.

Only the longest contiguous section of the reflective tape is taught-in by the SC300. If there are gaps in the reflection, e.g. because the reflective tape has been damaged or because there is an object in the protective field, the safety sensor system will ignore the shorter section of the reflective tape.

- Start the teach-in process as follows:





Using the internal teach-in key	Using the key-operated pushbutton for teach-in
<p>Actuate the internal teach-in key using the teach-in pin as follows:</p> <ul style="list-style-type: none"> ➤ Actuate for approx. 5 s (the diagnostics LED 4  flashes 5 times). <p>If the SC300 does not react, the internal teach-in key is probably locked. Start the teach-in process using the key-operated pushbutton for teach-in or unlock the teach-in key (see “Locking the internal teach-in key” on page 45).</p> <ul style="list-style-type: none"> ➤ Release for approx. 2 seconds (the diagnostics LED 4  flashes 2 times). ➤ Actuate for approx. 5 s (the diagnostics LED 4  flashes 5 times). ➤ Important: Now remove your hand from the protective field so that the SC300 can completely detect the protective field. 	<ul style="list-style-type: none"> ➤ Press the external key-operated pushbutton for teach-in for at least 0.5 seconds. The diagnostics LED 4  illuminates. ➤ Release the key-operated pushbutton for teach-in. The diagnostics LED 4  goes off.

Table 11 - Starting the teach-in process

The SC300 now teaches-in the current configuration and shape of the protective field. The process takes approx. 30 seconds. During the teach-in the flashing diagnostics LEDs indicate the configuration detected:





Display	Meaning
1 	OSSDs detected and OK
2 	External device monitoring (EDM) detected and activated
3 	Reset button detected and restart interlock activated
4 	Internal teach-in key unlocked

Table 12 - Meaning of the diagnostics LEDs during teach-in

- Using the LEDs, check whether the teach-in was successful:

























Status LEDs			Diagnostics LEDs				Meaning
			1	2	3	4	
							Teach-in was successful. If the protective field is clear and the restart interlock is deactivated, the SC300 switches to green.
							Teach-in was successful. If the protective field is clear and restart interlock is activated, the SC300 waits until the reset button is operated.
							Teach-in has failed (for measures see below).

Table 13 - LED displays after teach-in

- After teach-in it is imperative you check the protective field (see “Tests of the protective device by a specialist or authorized personnel” on page 41).

If the teach-in fails:

- **Check and rectify as necessary the following causes:**
 - Is the reflector fitted and clean?
 - Is the reflector perpendicular to the area of the protective field?
 - Is the reflective tape or are sub-segments of the tape very short?

- Are there other reflective objects in the immediate vicinity that could interfere with the system (e.g. reflective strips on safety clothing, packaging film, etc.)?
- Remove the cause.
- Perform teach-in again.

Internal restart interlock

The configuration of the restart interlock is defined by the wiring that is in place during the first or last teach-in process performed.

How to activate the internal restart interlock:

- Make the electrical connections for the reset button (see “Connecting the SC300” on page 30).
- Switch on the SC300.
- Perform a teach-in procedure.

If there is no signal on the *Reset/restart* input, then the safety camera system will activate the internal restart interlock and save this configuration in the device. The device is now waiting for the reset button to be pressed.

- Check the effectiveness of the protective device as described in “Test notes” on page 40.

How to deactivate the internal restart interlock:

- Permanently connect the *Reset/restart* input to 24V (“Connecting the SC300” on page 30).
- Switch on the SC300.
- Perform a teach-in procedure.

If 24V are present on the *Reset/restart* input, the safety camera system will deactivate the internal restart interlock and save this configuration in the device.

- Check the effectiveness of the protective device as described in “Test notes” on page 40.

External device monitoring

In the default delivery status, the external device monitoring is deactivated.

How to activate the external device monitoring:

- Make the electrical connections (“Connecting the SC300” on page 30).
- Switch on the SC300.
- Perform a teach-in procedure.

If the contacts to be monitored are connected to the *external device monitoring (EDM)* input, then the safety camera system will activate the external device monitoring and save this configuration in the device.

ATTENTION



The external device monitoring will remain deactivated without teach-in.

If you place the system in operation after connecting the contacts to the *external device monitoring (EDM)* input without teach-in, then the external device monitoring will remain deactivated. The system can therefore switch to green despite faulty contactors.

- Check the effectiveness of the protective device as described in “Test notes” on page 40.

How to deactivate the external device monitoring:

- Permanently connect the *External device monitoring (EDM)* input to 0V (“Connecting the SC300” on page 30).

- Switch on the SC300.
- Perform a teach-in procedure.

If there is no signal or 0 V on the *external device monitoring (EDM)* input, the safety camera system will deactivate the external device monitoring and save this configuration in the device.

- Check the effectiveness of the protective device as described in “Test notes” on page 40.

Locking the internal teach-in key

In the default delivery status the internal teach-in key is unlocked, i.e. it can be used. To permit remote teach-in and/or to help protect the configuration, you can connect an external key-operated pushbutton for teach-in and lock the internal teach-in key.

How to lock the internal teach-in key:

- Connect an external key-operated pushbutton for teach-In (“Connecting the SC300” on page 30).
- Switch on the SC300.
- Perform a teach-in procedure using the key-operated pushbutton for teach-in.

The SC300 locks the internal teach-in key and saves this configuration in the device. Teach-in can now only be performed using the key-operated pushbutton for teach-in.

- Check the effectiveness of the protective device as described in “Test notes” on page 40.

How to unlock the internal teach-in key:

- Switch on the SC300.
- Press the key-operated pushbutton for teach-in for at least 60 seconds.

The SC300 unlocks the internal teach-in key and saves this configuration in the device.

- If you no longer need the key-operated pushbutton for teach-in, remove it from the electrical installation. Otherwise the SC300 will again lock the internal teach-in key the next time the key-operated pushbutton for teach-in is actuated.
- Check the effectiveness of the protective device as described in “Test notes” on page 40.

Care and Maintenance

The SC300 safety camera system is maintenance-free in operation. The front screen on the SC300 as well as the reflective tape should be cleaned regularly and also cleaned immediately in case of soiling.

- Do not use aggressive cleaning agents.
- Do not use abrasive cleaning agents.

How to clean the front screen and the reflective tape:

- Use a clean and soft brush to remove dust from the front screen and the reflective tape.
- Then wipe the front screen and the reflective tape with a clean and damp cloth.

Note After cleaning, check the position of the camera and check the reflective tape for good condition to ensure it is not possible to reach over, reach under or stand behind the protective device.

Check the effectiveness of the protective device as described in “Test notes” on page 40.

Chapter 10

Fault Diagnosis

This chapter describes how to identify and rectify errors and malfunctions during the operation of the safety camera system.

In the event of faults or errors



ATTENTION



Cease operation if the cause of the malfunction has not been clearly identified.

- Stop the machine if you cannot clearly identify or allocate the error and if you cannot safely rectify the malfunction.

The system state “lock-out”

In case of certain faults or an erroneous configuration, the system can go into the “lock-out” state. The status LED  flashes with a short duty cycle  (short on/long off). To place the device back in operation:



- Rectify the cause of the fault following the information given in this chapter.
- Switch the power supply for the SC300 off and on again (e.g. by unplugging the system plug and reinserting it).

Rockwell Automation support

- If you cannot rectify an error with the help of the information provided in this chapter, please contact your local Rockwell Automation sales office or Allen-Bradley distributor.

Warnings and error messages of the LEDs

This section explains the meaning of the indications on the LEDs in case of warnings and errors and how you can react to them.

The procedure for troubleshooting varies for warnings  and errors  only in the last step: If there is an error, you must re-start the SC300 after rectification.

Status LEDs			Diagnostics LEDs				Meaning	Rectification of the error
			1	2	3	4		
●		○		○	○	○	Warning	Short-circuit or overcurrent on an OSSD ➤ Check the contactor. Replace, if necessary. ➤ Check the wiring for short-circuits or cross-circuits.
●		○		○	○	○	Error	
●		○	○		○	○	Warning	External device monitoring ➤ Check the contactors and their wiring, eliminate any wiring errors, if necessary. ➤ Switch the device off and back on again. Check the configuration of the external device monitoring (see page 14).
●		○	○		○	○	Error	
●		○	○	○		○	Warning	Reset button ➤ Check the reset button for correct function. The button may be defective or stuck. ➤ Check the wiring of the reset button for any short-circuit to 24V.
●		○	○	○		○	Error	
●		○	○	○	○		Warning	TEACH input ➤ Check the connection of the external key-operated pushbutton for teach-in.
●		○	○	○	○		Error	
●		○					Error	➤ Disconnect the supply voltage to the SC300 for at least 3 seconds. ➤ If the problem persists, replace the unit.

Table 14 - Indications on completion of the teach-in

Chapter 11

Technical Specifications

Data sheet

	Minimum	Typical	Maximum
General system data			
Protective field dimensions	See "Checking the dimensions of the protective field" on page 17.		
Type			
SC300 safety camera	3 (EN 61 496-1, IEC/TR 61 496-4)		
Safety integrity level ^①			
SC300 safety camera	SIL2 (IEC 61 508), SILCL2 (EN 62 061)		
Category			
SC300 safety camera	3 (EN ISO 13 849-1)		
Performance Level (Safety integrity level)			
SC300 safety camera	PL d (EN ISO 13 849-1)		
Test rate	50 1/s (EN ISO 13 849-1)		
Demand rate ^②	30 1/min (EN ISO 13 849-1)		
PFHd (mean probability of a dangerous failure per hour)	5.6×10^{-9}		
T _M (mission time)	20 years (EN ISO 13 849)		
Protection class	III (EN 50 178)		
Enclosure rating	IP 54 (EN 60 529)		
Resolution	20 mm, 24 mm or 30 mm		
Field of view	103° ± 3°		
Ambient operating temperature [C (F)]	-5° (23°)		+50° (122°)
Storage temperature [C (F)]	-25° (-13°)		+70° (158°) (≤24 h)
Humidity, taking into account the operating temperature range	EN 61 496-1, section 5.1.2 and section 5.4.2 as well as IEC/TR 61 496-4, section 5.4.2		
Air humidity (non-dewing)	15%		95%
Sinusoidal vibration	5 g, 10...55 Hz (EN 60 068-2-6)		
Shock resistance	10 g, 16 ms (EN 60 068-2-27)		
Lighting			
Wavelength	850 nm		
Ocular safety	Photobiologically harmless (IEC 62 471-7)		

① For detailed information on the exact design of your machine/system, please contact your local Rockwell Automation sales office or Allen-Bradley distributor.

② For SC300 safety camera the following applies: Between two demands for a safety-related reaction from the device, at least 100 internal or external tests must be performed.

Table 15 - Data sheet SC300

	Minimum	Typical	Maximum
Housing			
Material	Aluminium die-cast		
Dimensions	See "Dimensional drawings" on page 52.		
Total weight	0.355 kg		
Reflective tape (length × width) for resolution:			
20 mm	1.00 m × 37 mm		
24 mm	1.20 m × 37 mm		
30 mm	1.50 m × 48 mm		
Power-up delay after connecting the supply voltage			6 s
Electrical data			
Supply voltage V_s at the device (SELV) ❶❷	19.2V	24V	28.8V
Permissible cable resistance on the supply cable			1 Ω
Residual ripple ❸			
Operating current			
at 24V without output load			165 mA
with maximum output load			690 mA
Power consumption			
at 24V without output load			4 W
with maximum output load			19 W
Electrical connection	M12 × 8 (see "System connection" on page 30)		
Cable length for wire cross-section 0.25 mm ²			7.5 m
Synchronization	Electrical (see "System connection" on page 30)		
External device monitoring (EDM) input			
Resistance HIGH		2 k Ω	
Capacitance		15 nF	
Voltage (IEC 61 131-2)			
HIGH	11 V	24 V	30 V
LOW	-3 V	0 V	5 V
Static current	6 mA		15 mA

❶ To meet the requirements of the relevant product standards (e.g., EN 61 496-1), the external voltage supply for the devices (SELV) must be able to bridge a brief mains failure of 20 ms. Power supplies according to EN 60 204-1 satisfy this requirement. Suitable power supplies are available as accessories from Rockwell Automation (see "Accessories" on page 55).

❷ Within the limits of V_s .

❸ A fuse rated 2 A maximum, shall be installed in the isolated 24V DC power supply circuit to the device in order to limit the available current.

Table 15 - Data sheet SC300

	Minimum	Typical	Maximum
<i>Reset/restart</i> input (RESTART)			
Resistance HIGH		2 k Ω	
Capacitance		15 nF	
Voltage (IEC 61 131-2)			
HIGH	11 V	24 V	30 V
LOW	-3 V	0 V	5 V
Static current	6 mA		15 mA
Actuating time control switch input	120 ms		
<i>Teach-in/synchronization</i> (TEACH/SYNCH) input	The input must be operated by a key-operated switch (contact).		
Resistance HIGH		2 k Ω	
Capacitance		15 nF	
Voltage HIGH	11 V	24 V	30 V
Static current	6 mA		15 mA
Output signal switching devices (OSSDs)	2 PNP semiconductors, short-circuit protected ^❶ , cross-circuit monitored		
Switching voltage HIGH (active, U_{rms}) at 250 mA	$V_S - 2.7$ V		V_S
Switching voltage LOW (inactive)	0 V	0 V	3.5 V
Source switching current	6 mA		250 mA ^❷
Leakage current ^❸			250 μ A
Load inductance			2.2 H
Load capacity at 50 W			2.2 μ F
Permissible line resistance between device and load ^❹			2.5 Ω
Test pulse date ^❺			
Test pulse width		230 μ s	300 μ s
Test frequency		120 ms	
Response time			20 ms
Switch off time	100 ms		
Power-up delay of the OSSDs from red to green			30 ms
Contactors			
Permissible dropout time			300 ms
Permissible pick-up time			300 ms

Table 15 - Data sheet SC300

- ❶ Applies to the voltage range between U_V and 0 V.
- ❷ Switching currents ≤ 500 mA are allowed briefly (100 ms).
- ❸ In the case of a fault (0V cable open circuit) the maximum leakage current flowing in the OSSD cable. The downstream controller must detect this status as LOW. A safe PLC (Programmable Logic Controller) must be able to identify this status.
- ❹ Make sure to limit the individual cable resistance to the downstream controller to this value to ensure that a cross-circuit between the outputs is safely detected. (Also note EN 60 204 Electrical Machine Equipment, Part 1: General Requirements.)
- ❺ When active, the outputs are tested cyclically (brief LOW). When selecting the downstream controllers, make sure that the test pulses do not result in deactivation when using the above parameters.

Dimensional drawings

Dimensional drawing SC300

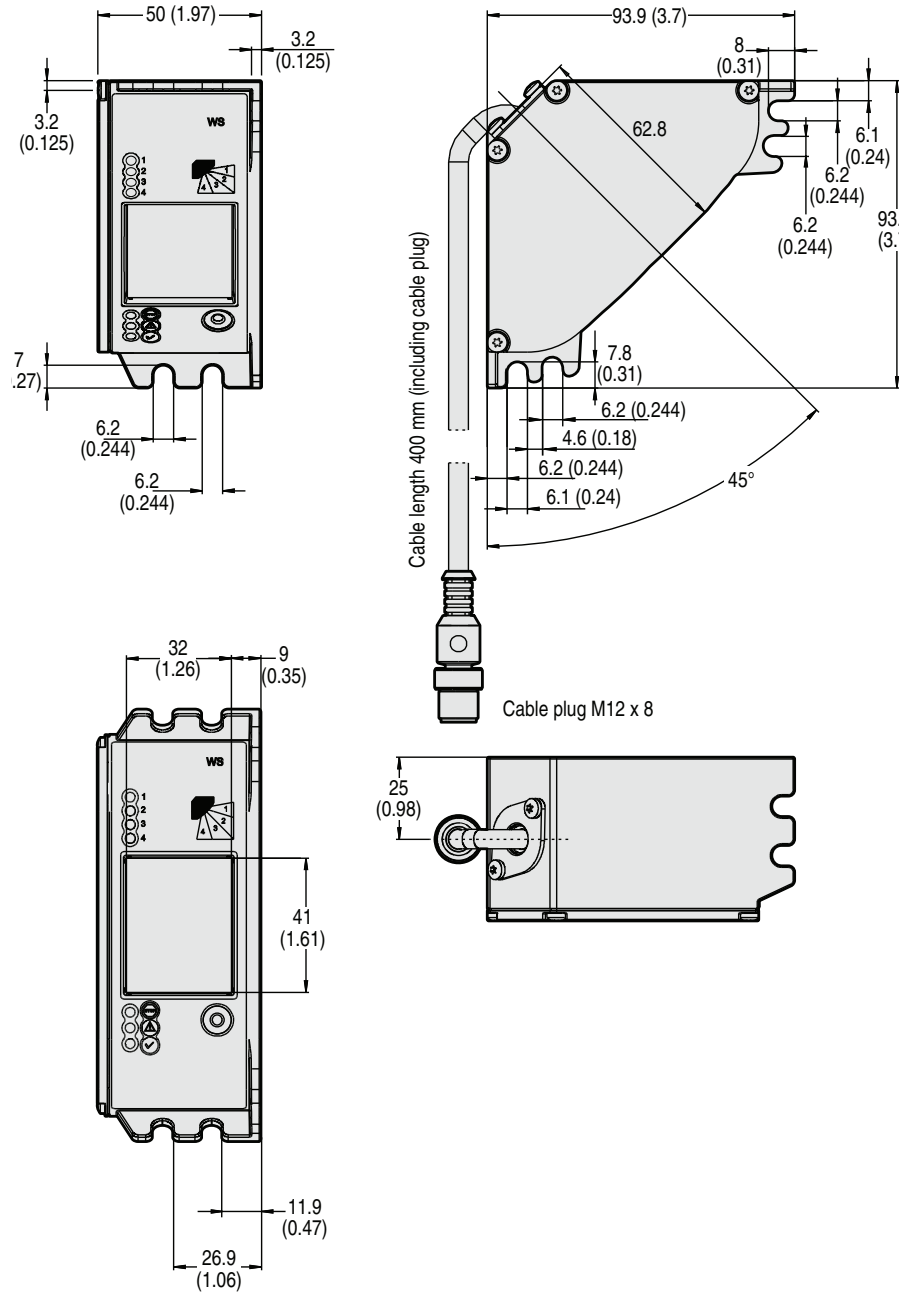

Figure 34 - Dimensional drawing SC300

Dimensional drawing, mounting kit 442L-ACAMBRK1

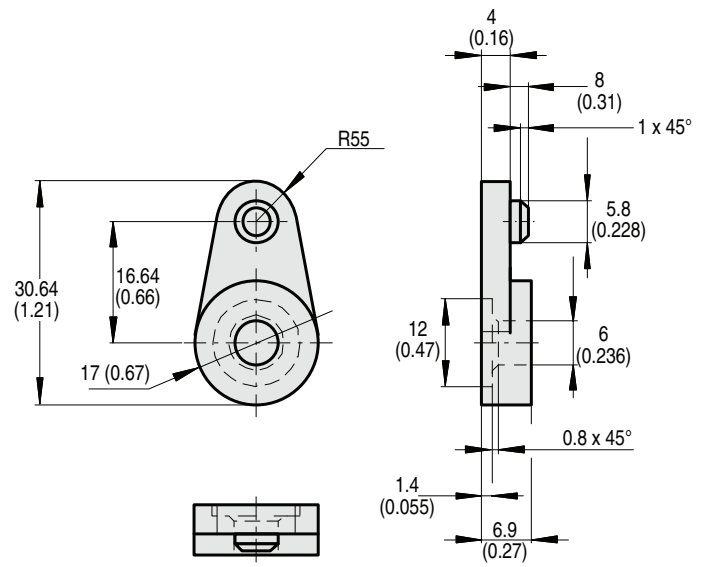

Figure 35 - Dimensional drawing, mounting kit

Ordering Information

Safety camera systems

Note In addition to the safety camera system, you will require one of the resolution sets.

Description	Part number
SC300 Safety camera system consisting of camera, teach-in pin, label "Important Information", operating instructions on CD-ROM and Quick-Start (instructions for quick commissioning), multi-lingual	442L-SAFCAM1
Resolution sets consisting of test rod (to suit the resolution) and two reflector strips	
Resolution set for resolution of 20 mm	442L-ACAM20MMKIT
Resolution set for resolution of 24 mm	442L-ACAM24MMKIT
Resolution set for resolution of 30 mm	442L-ACAM30MMKIT

Table 16 - Part numbers safety camera systems

Ordering example

If an SC300 safety camera is to be used in your application with a resolution of 20 mm. Then you must order the following:

- SC300 safety camera (Cat. 3, PL d according to EN ISO 13849-1) 442L-SAFCAM1
- Resolution set for resolution of 20 mm 442L-ACAM20MMKIT

Accessories

Description	Part number
Reflective tapes	
Robust version. Suitable for applications in which the reflective tape is subject to friction or weight.	
Test rods	
For resolution of 20 mm, 1 piece with \varnothing 20 mm	442L-ATRD20MM
For resolution of 24 mm, 1 piece with \varnothing 24 mm	442L-ATRD24MM
For resolution of 30 mm, 1 piece with \varnothing 30 mm	442L-ATRD30MM
Mounting kit	
To mount the SC300 on profile frames, two clamping lugs incl. screws	442L-ACAMBRK1
Power supply	
Power supply 24V, 100/240V AC, 50 W	7028789
Power supply 24V, 100/240V AC, 95 W	7028790
Connecting cable	
With cable socket M12 \times 8, straight socket/stripped	
2 m	889D-F8FB-2
5 m	889D-F8FB-5
7.5 m	889D-F8FB-10
Other accessories	
Teach-in pin	442L-ACAMTS

Table 17 - Part numbers accessories

Annex

Checklist for the manufacturer

Checklist for the manufacturer/installer for the installation of electro-sensitive protective equipment (ESPE)		
Details about the points listed below must be present at least during initial commissioning — they are, however, dependent on the respective application, the specifications of which are to be controlled by the manufacturer/installer.		
This checklist should be retained and kept with the machine documentation to serve as reference during recurring tests.		
1.	Have the safety rules and regulations been observed in compliance with the directives/standards applicable to the machine?	Yes <input type="checkbox"/> No <input type="checkbox"/>
2.	Are the applied directives and standards listed in the declaration of conformity?	Yes <input type="checkbox"/> No <input type="checkbox"/>
3.	Does the protective device comply with the required PL/SILCL and PFHd as per EN ISO 13 849-1/EN 62 061 and the type as per EN 61 496-1?	Yes <input type="checkbox"/> No <input type="checkbox"/>
4.	Is the access to the hazardous point only possible through the protective field of the ESPE?	Yes <input type="checkbox"/> No <input type="checkbox"/>
5.	In the case of hazardous point protection, have appropriate measures been taken to prevent (mechanical point-of-operation guarding) or monitor unprotected presence in the hazardous area and have these been secured against removal?	Yes <input type="checkbox"/> No <input type="checkbox"/>
6.	Are additional mechanical protective measures fitted and secured against manipulation which prevent reaching under, over or around the ESPE?	Yes <input type="checkbox"/> No <input type="checkbox"/>
7.	Has the maximum stopping and/or stopping/run-down time of the machine been measured, specified and documented (at the machine and/or in the machine documentation)?	Yes <input type="checkbox"/> No <input type="checkbox"/>
8.	Has the ESPE been mounted such that the required safety distance from the nearest hazardous point has been achieved?	Yes <input type="checkbox"/> No <input type="checkbox"/>
9.	Are the ESPE devices correctly mounted and secured against manipulation after adjustment?	Yes <input type="checkbox"/> No <input type="checkbox"/>
10.	Are the required protective measures against electric shock in effect (protection class)?	Yes <input type="checkbox"/> No <input type="checkbox"/>
11.	Is the control switch for resetting the protective device (ESPE) or restarting the machine present and correctly installed?	Yes <input type="checkbox"/> No <input type="checkbox"/>
12.	Are the outputs on the ESPE (OSSD, AS-Interface Safety at Work interface) integrated in accordance with the required PL/SILCL as per EN ISO 13 849/EN 62 061, and do they comply with the circuit diagrams?	Yes <input type="checkbox"/> No <input type="checkbox"/>
13.	Has the protective function been checked in compliance with the test notes of this documentation?	Yes <input type="checkbox"/> No <input type="checkbox"/>
14.	Are the given protective functions effective at every setting of the operating mode selector switch?	Yes <input type="checkbox"/> No <input type="checkbox"/>
15.	Are the switching elements activated by the ESPE, e.g. contactors, valves, monitored?	Yes <input type="checkbox"/> No <input type="checkbox"/>
16.	Is the ESPE effective over the entire period of the dangerous state?	Yes <input type="checkbox"/> No <input type="checkbox"/>
17.	Once initiated, will a dangerous state be stopped when switching the ESPE on or off and when changing the operating mode, or when switching to another protective device?	Yes <input type="checkbox"/> No <input type="checkbox"/>
18.	Has the information label for the daily check been attached so that it is easily visible for the operator?	Yes <input type="checkbox"/> No <input type="checkbox"/>
This checklist does not replace the initial commissioning, nor the regular inspection by qualified safety personnel.		

Compliance with EU Directives

EU declaration of conformity (extract)

Rockwell Automation herewith declares that the SC300 safety sensor system is in conformity with the provisions of the following EU directive(s) (including all applicable amendments), and that the respective standards and/or technical specifications have been used as a basis for this declaration.

You may obtain the EU Declaration of Conformity with the standards used at rok.auto/certifications.

Directives used:

- Machinery Directive
- EMC Directive
- RoHS Directive

List of tables

Tab. 1: Maximum protective field dimensions as a function of the resolution 8

Tab. 2: Permissible restart interlock configurations on the SC300 13

Tab. 3: Meaning of the status LEDs of the SC300 15

Tab. 4: Meaning of the diagnostics LEDs 16

Tab. 5: Protective field dimensions allowed for a rectangular protective field at a resolution of 20 mm 17

Tab. 6: Protective field dimensions allowed for a rectangular protective field at a resolution of 24 mm 18

Tab. 7: Protective field dimensions allowed for a rectangular protective field at a resolution of 30 mm 18

Tab. 8: Length of the unmonitored area in the case of mounting in a frame 22

Tab. 9: Pin assignment system connection SC300 30

Tab. 10: Starting the teach-in process 43

Tab. 11: Meaning of the diagnostics LEDs during teach-in 43

Tab. 12: LED displays after teach-in 43

Tab. 13: Indications on completion of the teach-in 48

Tab. 14: Data sheet SC300 49

Tab. 15: Part numbers safety camera systems 54

Tab. 16: Part numbers accessories 55

List of illustrations

Fig. 1: Operating principle of the SC300 11

Fig. 2: Hazardous point protection with one SC300, mounting in the frame (left figure) 12

Fig. 3: Hazardous point protection with one SC300, mounting on the frame (right figure) 12

Fig. 4: Hazardous point protection with two SC300, placement in opposite directions (left figure) . . . 12

Fig. 5: Hazardous point protection with two SC300, placement at corner (right figure) 12

Fig. 6: Outline drawing of the protective operation 13

Fig. 7: Status LEDs of the SC300 15

Fig. 8: Diagnostics LEDs of the SC300 15

Fig. 9: Safety distance from the hazardous point 19

Fig. 10: Avoiding unmonitored areas due to mounting on a frame 22

Fig. 11: Dangerous mounting mistake: maximum protective field width exceeded 23

Fig. 12: The correct installation (above) must eliminate the errors (below) reaching over, reaching under and standing behind 24

Fig. 13: Example: mounting with sliding nuts on different thickness profiles 25

Fig. 14: Example: mounting with clamping lugs on different thickness profiles 25

Fig. 15: Mounting in a frame 26

Fig. 16: Correct arrangement of the reflective tapes at joints 26

Fig. 17: Permissible divergence of the reflective tape from the optical axis of the camera as a function of the distance at 20 mm resolution 27

Fig. 18: Permissible divergence of the reflective tape from the optical axis of the camera as a function of the distance at 24 mm resolution 27

Fig. 19: Permissible divergence of the reflective tape from the optical axis of the camera as a function of the distance at 30 mm resolution 28

Fig. 20: System connection SC300 30

Fig. 21: Connecting the SC300 without external device monitoring (EDM), without internal restart interlock and without external key-operated pushbutton for teach-in 31

Fig. 22: Connecting the SC300 with external device monitoring (EDM), with internal restart interlock and with external key-operated pushbutton for teach-in 31

Fig. 23:	Connection of two SC300 with synchronization	32
Fig. 24:	Connection diagram SC300 at UE410 Flexi	33
Fig. 25:	Connection diagram SC300 at UE10-30S	34
Fig. 26:	Application with small protective field (1 × SC300)	37
Fig. 27:	Application with large protective field (2 × SC300)	38
Fig. 28:	Ergonomic workplace design due to the use of two SC300	38
Fig. 29:	Mounting with automatic material transport into the workstation	39
Fig. 30:	Daily test of the protective device with the test rod	41
Fig. 31:	Dimensional drawing SC300	52
Fig. 32:	Dimensional drawing, mounting kit	53

Rockwell Automation Support

Use the following resources to access support information.

Technical Support Center	Knowledgebase Articles, How-to Videos, FAQs, Chat, User Forums, and Product Notification Updates.	https://rockwellautomation.custhelp.com/
Local Technical Support Phone Numbers	Locate the phone number for your country.	http://www.rockwellautomation.com/global/support/get-support-now.page
Direct Dial Codes	Find the Direct Dial Code for your product. Use the code to route your call directly to a technical support engineer.	http://www.rockwellautomation.com/global/support/direct-dial.page
Literature Library	Installation Instructions, Manuals, Brochures, and Technical Data.	http://www.rockwellautomation.com/global/literature-library/overview.page
Product Compatibility and Download Center (PCDC)	Get help determining how products interact, check features and capabilities, and find associated firmware.	http://www.rockwellautomation.com/global/support/pcdc.page

Documentation Feedback

Your comments will help us serve your documentation needs better. If you have any suggestions on how to improve this document, complete the How Are We Doing? form at http://literature.rockwellautomation.com/idc/groups/literature/documents/du/ra-du002_-en-e.pdf.

Rockwell Automation maintains current product environmental information on its website at <http://www.rockwellautomation.com/rockwellautomation/about-us/sustainability-ethics/product-environmental-compliance.page>.

Allen-Bradley, Guardmaster, Rockwell Automation, and Rockwell Software are trademarks of Rockwell Automation, Inc.

Trademarks not belonging to Rockwell Automation are property of their respective companies.

Rockwell Otomasyon Ticaret A.Ş., Kar Plaza İş Merkezi E Blok Kat:6 34752 İçerenköy, İstanbul, Tel: +90 (216) 5698400

www.rockwellautomation.com

Power, Control and Information Solutions Headquarters

Americas: Rockwell Automation, 1201 South Second Street, Milwaukee, WI 53204-2496 USA, Tel: (1) 414.382.2000, Fax: (1) 414.382.4444

Europe/Middle East/Africa: Rockwell Automation NV, Pegasus Park, De Kleetlaan 12a, 1831 Diegem, Belgium, Tel: (32) 2 663 0600, Fax: (32) 2 663 0640

Asia Pacific: Rockwell Automation, Level 14, Core F, Cyberport 3, 100 Cyberport Road, Hong Kong, Tel: (852) 2887 4788, Fax: (852) 2508 1846