



Detectors

Infrared flammable gas detector you can trust

Nimbus

Nimbus

Nimbus is compact and lightweight but rugged. Maintenance is simple, and because it is compatible with handheld and laptop computers, units can be checked by a single engineer.

It can be integrated into existing systems with ease. Nimbus protects staff and property without making your life complicated.

Rugged & reliable

Nimbus has been designed to be **lightweight but tough**.

Even in the dirtiest conditions Nimbus still functions. The optics operate at up to 90% obscuration. While still detecting gas, at 75% obscuration a dirty optics warning flashes **so you know when to clean Nimbus**.

Dust and water ingress are not a problem either as **Nimbus is rated IP66 and IP67**. Allied to this Nimbus has full approvals from both **EUROPE and North America**.

Nimbus has a **MTBF of 10 years**. This figure has been independently assessed using the MIL Handbook 217F/2/12/91

In short you can rely on Nimbus to protect you.

One man calibration

Nimbus is compatible with Windows software, which means that a Windows compatible **portable PC can be used to check gas levels, find faults and change configurations in the field**. Only one person is required to do this.

Nimbus is fitted with an optical Communications Interface Module, to allow **connection of a PC without opening the detector**.

For detectors installed in a hazardous area, the configuration and status can be checked remotely using the Modbus serial link.

Simple maintenance

Nimbus has a local external status light which shows, at a glance, if the unit is in normal function or fault. When a hazard is detected it indicates both rising gas and alarm levels.

The status light clearly indicates 22 further conditions for **instant diagnosis**.

Nimbus is simple to use even in inaccessible areas. A duct mounting plate is available, which incorporates a **remote gassing port** to allow calibration checking without requiring entry into the duct.

Flexible installation

Nimbus can be integrated into existing situations with ease. It has a RS485 output and dual redundant 4-20mA outputs, compatible with metric and imperial armoured cable and conduit.

The **Modbus serial link** allows addressable detectors to be looped **providing a remote control and interrogation facility**.

For facilities where Nimbus is replacing a pellistor based detector the **pellistor mimic means that existing cabling can be retained to reduce upgrade costs**.

Nimbus, the total system solution

It can interface with any standard control system, or combination of systems, new or old.

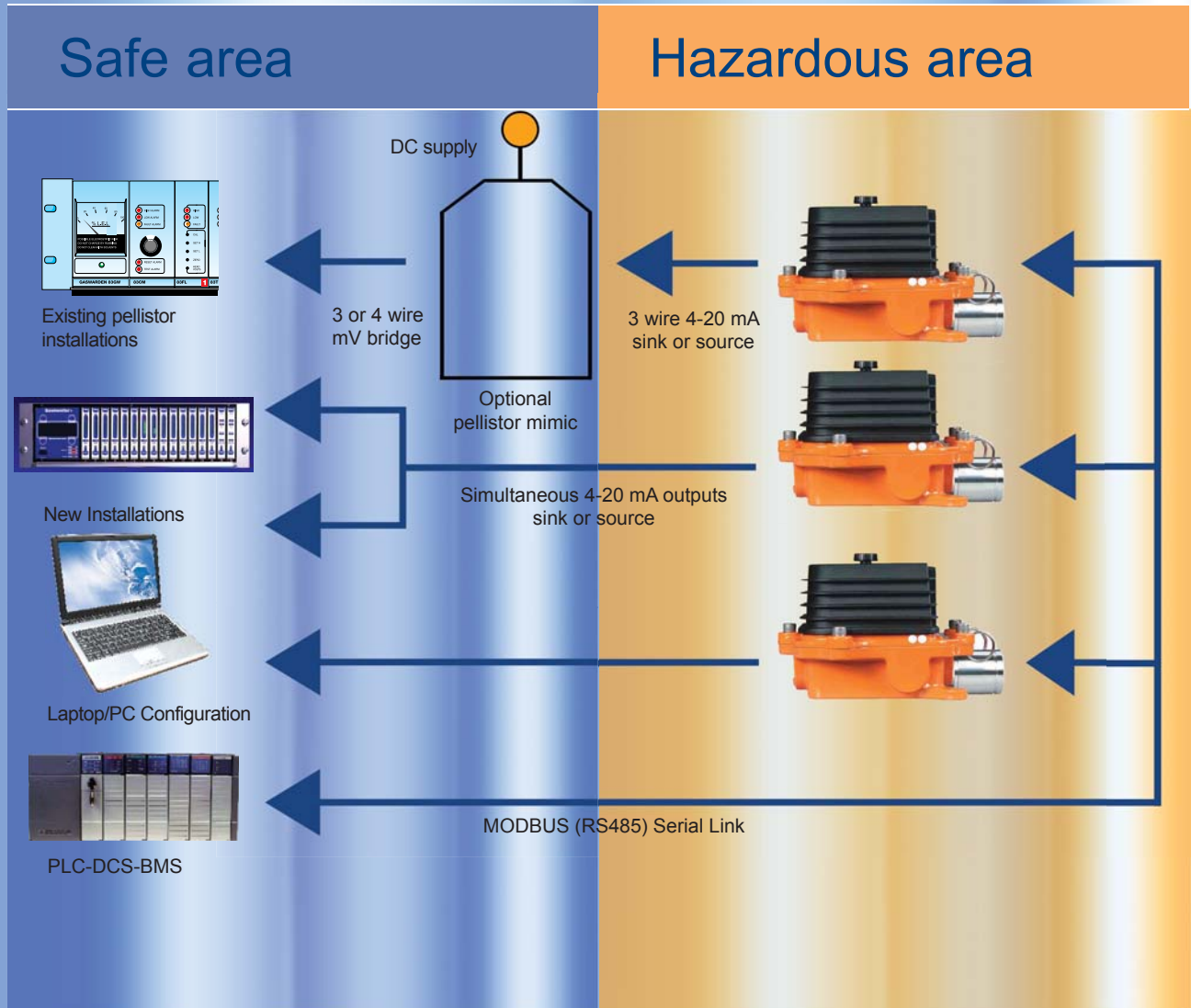

Mounting Options

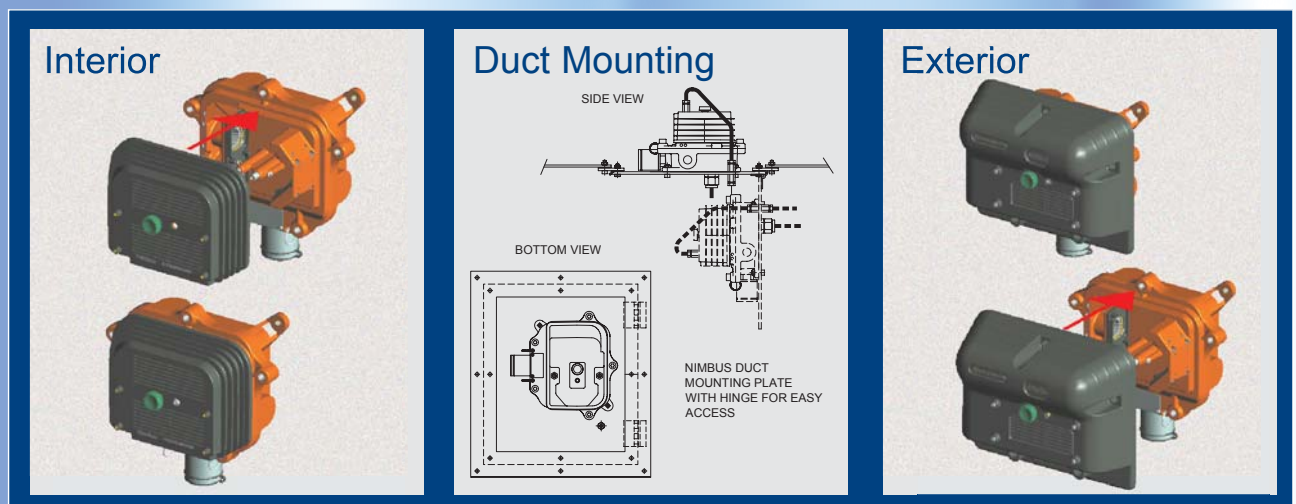

Nimbus

Infrared flammable gas detector



Model	Nimbus	
Function the list of available	The detection of hydrocarbon gases C 1 to C 6 + ethanol, ethylene and LPG in LEL range by means of infrared absorption. Contact Crowcon for a full	
Dimensions	125 x 170 x 210 mm (5 x 6.8 x 8.3 ins)	
Weight	2.5 kg, (5.5 lbs)	
Construction	LM25 marine grade alloy, polyester powder coated	
Optical system	Dual wavelength, dual detector	
Optical performance	Correct operation with up to 90% obscuration Dirty optics warning above 75% (configurable) Heated optics to avoid condensation.	
Power consumption	Operating voltage: 10 to 32 V dc (nominal 24 V)	
– LK2 fitted (Anti Condensation Heater)	Operating current: 300 mA max (7.2 W @ 24 V, 3 W @ 10 V)	
– LK2 not fitted	Operating current: 180 mA max (4.3 W @ 24 V, 1.8 W @ 10 V)	
Typical output signals	All levels configurable - simultaneous sink and source output 0 mA: fault 2 mA: dirty optics 4-20 mA: 0-100% LEL 24 mA: over range	
Status light	Green - normal function Orange - fault Red - detecting gas 22 other conditions indicated by flash rate	
Communications	Modbus RS485 serial link	
Functional testing	Flow adaptor for gassing	
Accuracy	±2% of gas reading @ ≤ 50% LEL ±5% of gas reading @ > 50% to 100% LEL	
Response time	<7 seconds - T ₉₀ <3 seconds – instantaneous high levels of gas	
Temperature range	-40°C to 65°C (-40°F to 149°F)	
Humidity range	0 to 99% RH non-condensing	
European Approvals and Standards	 ATEX II 2G EEx d IIB+Hydrogen T6 Safety Cert. No: DEMKO01ATEX130838	Suitable for use in Zone 1 or Zone 2 Hazardous Areas
UL Approval and Standards	 T _{amb} = -40°C to 65°C EN50014, EN50018 Class 1, Div 1, Groups B, C & D T _{amb} = -20°C to 65°C UL 1203 (When connected to a class 2 Power Supply)	
Ingress protection	IP66 (jets of water) IP67 (temporary submersion), NEMA 4X	
Light immunity	Totally immune to all external light, both constant and modulated (including sunlight, white light, flashing beacons etc.)	
General immunity	Totally immune to all catalyst poisons	
Electromagnetic compatibility	Gas detection standard EN50270 RF emissions EN50081-2 RF immunity EN50082-2	