

---

# CellarSafe

## Carbon Dioxide and Oxygen Safety Monitor

---

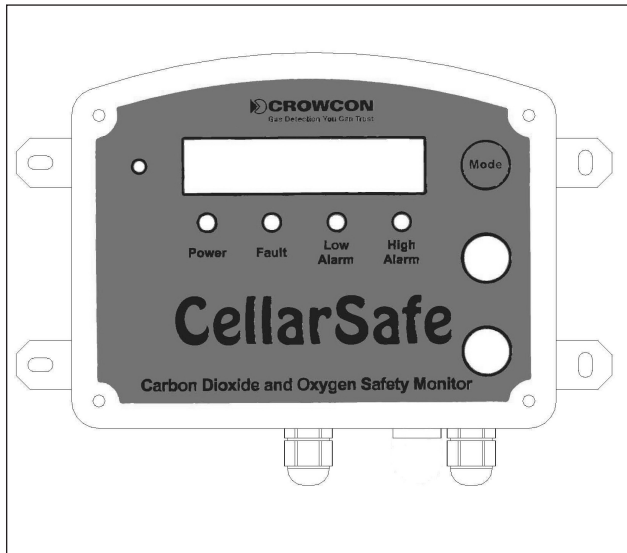

### Installation and operating instructions for the CellarSafe Monitor and the CellarSafe Calibration Unit

**M07234**

May 2008  
Issue 6

**Warning**

Please take care that CellarSafe is installed and operated in accordance with these instructions.

The product may not be able to warn of gas hazards if used in any other way.

---

# CellarSafe

## Carbon Dioxide and Oxygen Safety Monitor

---

### Contents

I. Introduction .....	1
1.1 Product overview.....	1
1.2 Product description .....	1
1.3 Normal and fault states of LEDs.....	2
1.4 Alarm conditions for CellarSafe base and repeater units.....	2
1.5 Options for the CellarSafe .....	5
II. Installation .....	6
2.1 General.....	6
2.2 Mounting.....	6
2.3 Cabling requirements .....	7
2.4 Electrical connections for external alarm equipment	7
III. Operation and set up .....	9
3.1 Mode button.....	9
3.2 Operator display panel .....	9
3.3 Set up .....	9
3.4 Self-Test .....	9
3.5 Alarm levels.....	10
3.6 In the event of a low or high alarm condition .....	10
IV. Specification.....	11
V. Troubleshooting guide.....	12
VI. Calibration, testing and routine maintenance .....	13
6.1 Introduction .....	13
6.2 Fuses.....	13
6.3 Calibration .....	13
6.4 Calibrating the CellarSafe gas monitor .....	14



---

# I. Introduction

---

## 1.1 Product overview

CellarSafe is a carbon dioxide and oxygen fixed monitoring system designed to monitor gas levels in a confined space, such as a beer cellar. The system consists of one base unit housing the gas monitoring system and is supplied with one repeater unit to be located in a safe position outside the confined area.

Version 1 is a carbon dioxide monitor only, which looks for rising gas levels.

Version 2 is a combined system which monitors both rising levels of carbon dioxide and falling levels of oxygen.

CellarSafe operates two alarm relays if the gas level exceeds the two pre-set alarm levels. The output from these relays can be used to control external visual or audible alarms, or ancillary equipment such as a fan.

CellarSafe is designed for easy installation using mains power supply and has been designed for one-man installation. The alarm levels are factory set and the relays are 'fail-safe' so the alarms will activate if the power supply fails.

The CellarSafe is supplied with one repeater unit. The repeater unit provides a remote interface to mimic the gas monitoring alarms, fault alarm, power indicator, MODE button and sounder of the base unit. A series of repeater units can be daisy-chained together to provide an extension of monitoring system. Each additional repeater unit is provided with a 9 m cable.

## 1.2 Product description

CellarSafe consists of two components: a base unit and a repeater unit.

The base unit is a single shell housing the gas monitors. The display panel at the front contains a liquid crystal display, MODE button, four illuminating LEDs and a sounder (see Figure 1.1). Electrical connections for mains power, two relay outputs and the repeater unit are located at the bottom of the base unit.

A 2 m mains cable and two carbon dioxide warning labels are also provided.

The repeater unit (see Figure 1.2) is supplied with a 9 m connection cable. The repeater unit mimics the base unit but does not have the display panel.

## 1.3 Normal and fault states of LEDs

The illuminating LEDs on the base unit and all repeater units indicate conditions as below.

### Flashes when the system is running:

POWER green LED	If this LED is extinguished the system is not running, if the LED is on continuously a fault condition is present.  If the battery backup option is fitted, the sounder will beep every 20 seconds in the event of mains power failure.
FAULT yellow LED	Flashes when there is a system fault.
LOW ALARM red LED	Flashes when the low alarm level (pre-alarm) is exceeded.
HIGH ALARM red LED	Flashes when the high alarm level (main alarm) is exceeded.

## 1.4 Alarm conditions for CellarSafe base and repeater units

*(Indications on some versions may differ in some details. Check specification sheet supplied with unit)*

When the low or high alarm gas level is exceeded the sounder and alarm LEDs will operate, Table 1.1 outlines the alarm conditions.

Table 1.1: Alarm conditions for the CellarSafe and repeater units

Gas levels	RELAY INDICATION	LED INDICATION	SOUNDER INDICATION
Normal	Not active	No alarm LEDs	No sound

### Increasing gas levels of carbon dioxide

Gas level > Low Alarm	Low Alarm	Low Alarm LED flashing	Long beep once per second
Gas level > High Alarm	Low and High Alarm	Low and High Alarm LEDs flashing	Long beep once per second

<b>Gas levels</b>	<b>RELAY INDICATION</b>	<b>LED INDICATION</b>	<b>SOUNDER INDICATION</b>
<b>Decreasing gas levels of oxygen</b>			
Gas level > Low Alarm	Low Alarm	Low Alarm LED flashing	Long beep once per second followed by one short beep
Gas level > High Alarm	Low and High Alarm	Low and High Alarm LEDs flashing	Long beep once per second followed by one short beep

The MODE button is used to communicate with the CellarSafe after an alarm is triggered. In the first instance pressing and holding the MODE button for 5 seconds will silence the CellarSafe alarm sounder, the alarm LEDs will continue to flash in an alarm condition (i.e. gas is still present or in the case of oxygen, depleted).

When the gas level has returned to normal the illuminating alarm LEDs will extinguish but will reactivate the sounder and illuminating LEDs if the alarm level is exceeded again. The CellarSafe is set to use non-latching alarms - the LEDs will automatically extinguish when the gas level returns to normal.

If the system fault alarm is activated the CellarSafe will sound a beep twice every second and the yellow warning light will flash. The system fault alarm will activate if a sensor fault condition occurs.

Electrical connections for external alarm equipment are located within the main CellarSafe base unit. One connection terminal is provided for the main alarm and one for the pre alarm.

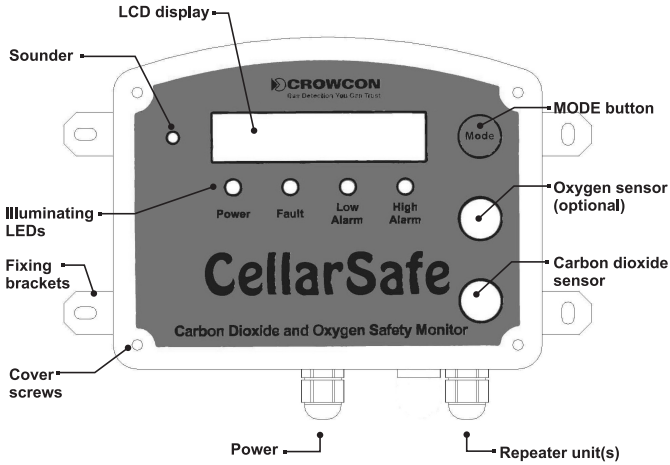

Figure 1.1 The CellarSafe with carbon dioxide and optional oxygen monitors.

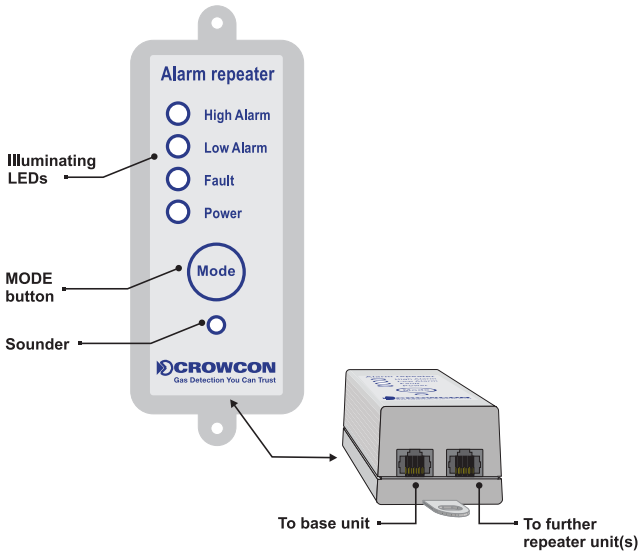

Figure 1.2 The CellarSafe Repeater Unit.



## 1.5 Options for the CellarSafe

### *Oxygen monitor*

CellarSafe can be fitted with an oxygen monitor to provide dual monitoring of safe gas levels of carbon dioxide and oxygen.

### *Backup battery*

The CellarSafe can be fitted with a backup battery providing 2 hours of backup in the event of mains power failure.

When in backup mode the CellarSafe will emit a beep once every 20 seconds. Up to 4 repeater units can be used with the CellarSafe base unit.

### *Additional repeater unit*

Each additional repeater unit is supplied with a 9 m cable. For a full list of CellarSafe units and options, see Table 1.2 below.

Table 1.2: CellarSafe units and options

ITEM	PART NUMBER
CellarSafe - complete unit	Contact Crowcon
CellarSafe with battery backup	Contact Crowcon
CellarSafe with oxygen sensor module	Contact Crowcon
CellarSafe with battery backup and oxygen sensor module	Contact Crowcon
† Repeater unit including cable	99S38001
Calibration Gas	CO3324
Field Calibration Unit	99S38002

*†Additional repeater units come with 9 m cable.*

## Important

- **Where battery back-up has been specified, batteries will be found inside the unit, but not yet connected. Connect before use.**
- **The battery backup unit and the oxygen option contain non-environmentally friendly elements. Please dispose in an environmentally and safe manner or return to Crowcon for safe disposal.**

## II. Installation

When carrying out any installation work, ensure that local regulations and site procedures are followed.

### 2.1 General

This manual contains instructions for installing the CellarSafe base unit and repeater unit. Before beginning installation of the CellarSafe please follow the mounting, cabling and installation instructions, paying close attention to the location of the base unit.

### 2.2 Mounting

The CellarSafe base unit is designed for wall mounting and should be located near to the valves and manifold within the confined space approximately 0.5m from ground level. Fixing holes are attached to the unit so that it can be attached to the wall with appropriate screws and wall plugs.

The CellarSafe repeater unit should be mounted outside of the confined space -for example, on the doorframe at the entrance, using the fixing brackets provided.

The height should be at eye level for ease of use.

Additional repeater units are mounted in the same way. Suitable locations are outside of the confined area, for example, at a secondary exit or positioned at a different location normally occupied by staff, in a safe position, within the building.

The CellarSafe is not suitable for outdoor or hazardous environments.

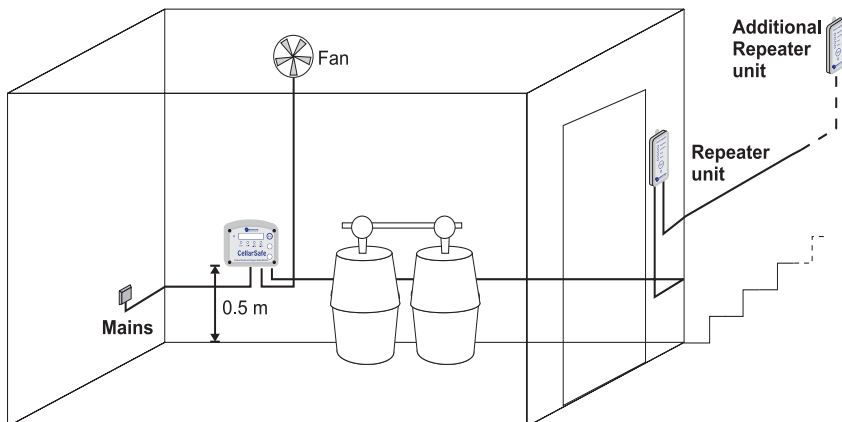

Figure 2.1 Where to locate and mount your CellarSafe unit

## 2.3 Cabling requirements

CellarSafe is fitted with an AC plug for convenience. If, however, permanent installation is required, it should be wired to a dedicated AC spur led from a circuit breaker. The spur or mains plug should be fitted with a 3A fuse.

The circuit breaker should be marked as the disconnecting device for the CellarSafe. It must comply with the relevant requirements of IEC 947-1 and IEC 947-3. These procedures ensure that the installation complies with the requirements EN 61010-1 (Low Voltage Directive).

The repeater unit supplied with CellarSafe does not need specialist cabling. Each additional repeater unit is supplied with a 9 m cable as standard.

## 2.4 Electrical connections for external alarm equipment

The CellarSafe has two alarm relays to which external visual and audible alarms or other ancillary equipment, such as a fan, can be connected. An example electrical connection is shown in Figure 2.2.

Before connecting the equipment, ensure the mains supply is switched off. Unscrew the top cover to gain access to the screw terminal connectors on the PCB board.

The two alarm relay connections are each marked NC (normally closed), NO (normally open) and common (C). Use the NO and C screw terminal connectors as shown in Figure 2.2. (L = live, N = neutral)

**NOTE:** *The alarm relays are shown in the normally energised state. When installing the device the normally open (NO) connection will be closed since there is no power. Similarly, the normally closed (NC) connection will be open.*

The CellarSafe can be connected to two fans, one to each alarm relay.

If the pre-alarm is exceeded the first fan will activate.

If carbon dioxide levels increase further, reaching a level that triggers the main alarm, the second fan will activate to increase ventilation.

Dual-speed fans are also available for a similar effect: low speed and high speed corresponding to low and high alarm respectively.

It is recommended that external equipment should be fused.

**NOTE:** *The relay contacts must not be used to switch loads drawing more than 10 A.*

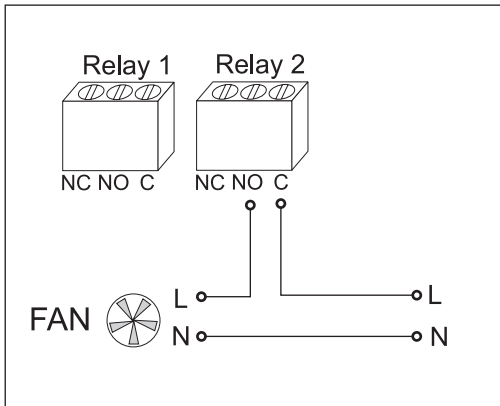

Figure 2.2 Alarm relay electrical connections.

---

## III. Operation and set up

---

### 3.1 Mode button

The CellarSafe base unit and repeater unit provide a MODE button to communicate with the CellarSafe. The MODE button is used in the event of an alarm or fault occurring, and during the self-testing procedure.

### 3.2 Operator display panel

The operator display panel provides a reading of the concentration of gas levels being monitored. Carbon dioxide, CO<sub>2</sub>, is shown as a percentage concentration level and at normal gas level (i.e. safe levels) will display 0 to 0.2%.

With the oxygen monitor option, the display will alternate between showing the carbon dioxide gas concentration, CO<sub>2</sub>, and the oxygen gas level concentration, O<sub>2</sub>. Normal oxygen gas level concentration is 20.9%.

To activate the display backlight, press the MODE button.

### 3.3 Set up

The CellarSafe requires no configuration of the gas monitors or alarm settings. Once the CellarSafe and repeater units are installed, you can switch on the mains supply. The CellarSafe and repeater unit will become fully operational after a 40-second warm-up period. The alarms and sounder will operate momentarily during this period and the operator display panel will test the display settings.

#### Carbon dioxide warning labels

The CellarSafe is provided with two carbon dioxide warning labels. It is important to fill in the contact and telephone details of the person responsible for the safety of the confined space on labels. Affix the labels in clear, eye-level positions near the CellarSafe unit, either at the entrance to the confined area being monitored, or near a repeater unit.

### 3.4 Self-Test

A self-test routine is provided to test the CellarSafe and any ancillary equipment attached via the alarm relays. To run the self-test routine, press and hold the MODE button for 5 seconds.

The self-test can be initiated from the base unit or any of the repeater units.

The operator display panel will illuminate and test all display segments. The unit will enter alarm condition for a period of 10 seconds illuminating the alarm LEDs, activating the sounder and additional ancillary alarm equipment connected to the CellarSafe relays.

### 3.5 Alarm levels

Alarm levels vary depending on CellarSafe configuration. Please refer to the specification sheet supplied with product, or contact Crowcon quoting the part number of the unit.

### 3.6 In the event of a low or high alarm condition

If the low or high level alarm levels are exceeded the CellarSafe will activate the alarm relays, illuminate the alarm LEDs and activate the sounder on the base unit and all repeater units.

Carbon dioxide levels exceeded ( $\text{CO}_2$ ): The sounder will beep once every second

Oxygen levels exceeded ( $\text{O}_2$ ): The sounder will emit one long beep followed by one short beep once every second.

To silence the sounder, press and hold the MODE button for 5 seconds.

**NOTE:**  $\text{CO}_2$  alarms may be subject to a 25-second time delay to prevent false alarms when exchanging gas cylinders. Oxygen alarms are instantaneous.

**In the event of an alarm condition, DO NOT ENTER THE ROOM. Follow safety procedures as indicated on the carbon dioxide warning labels.**

## IV. Specification

### CellarSafe specification

Dimensions	210 x 150 x 75 mm
Weight	1.3 kg
Operating voltage	230 V, 50/60 Hz ac, 16 VA, double insulated 115 V ac option available
Operating temperature	+3°C to +50°C (37°F to 122°F)
Warm up time	40 seconds
IP rating	IP 65
Display	Backlit LCD, 13.5 mm high digits
Instrument status indicators	2 gas level concentration alarm LEDs, red 1 fault alarm LED, yellow 1 power LED, green 1 sounder (>82 dB @ 10 cm)
Cable length	2 m
Fixing centres	4 at 192 mm x 72.5 mm
Humidity	0-99% RH non-condensing
Relay outputs	SPCO 10 A, 240 V ac / 30 V dc

### Repeater unit specification

Dimensions	143 x 56 x 41 mm
Weight	120 g
IP rating	IP54
Instrument status indicators	2 gas level concentration alarm LEDs, red 1 fault alarm LED, yellow 1 power LED, green 1 sounder (>82 dB @ 10 cm)
Cable length	9m
Fixing centres	2 at 130mm
Operating temperature	0°C to +50°C (32°F to 122°F)

The oxygen sensor (if fitted) must be replaced every 3 years. Contact Crowcon for part numbers and prices.

## V. Troubleshooting guide

Problem	Cause	Solution
Power LED off	Power not reaching processor	Check base unit is plugged in and electrical supply is switched on; check mains fuse
Power LED on continuously	Processor not working correctly	Call service engineer
Fault light on and sounder emitting rapid beeps	Sensor fault	Call service engineer
Operator display panel displaying an error	Base unit has been opened for servicing or wiring with battery option installed	Wait for 40 second warmup period. If error continues to be displayed call service engineer



---

# VI Calibration, testing and routine maintenance

---

## 6.1 Functional Testing

For optimum performance, it is recommended that Cellarsafe is calibrated every six months using the Cellarsafe calibration unit. A minimum requirement is that units are functionally tested as described below. However, it should be noted that full re-calibration may be required after 3 - 4 years of use.

The oxygen sensor (if fitted) must be replaced every 3 years. Contact Crowcon for part numbers and prices.

It is also necessary to test this product at least every twelve months to ensure that the sensors and alarms are operational. Periodic testing may be performed simply by using exhaled breath to generate high CO<sub>2</sub> and low oxygen alarms on units with an oxygen sensor fitted. Exhaled breath contains approximately 4% CO<sub>2</sub> and 16% oxygen, and therefore contains sufficient levels of each gas to cause alarms on the CellarSafe monitor.

To test the alarms, blow into a plastic bag and hold the open end of the inflated bag tightly over the sensor(s) until the alarms activate. The CellarSafe display will show increased levels of CO<sub>2</sub> and decreased levels of oxygen (on units with an oxygen sensor fitted), and the alarms should activate after approximately 10-15 seconds for oxygen and 25 seconds for CO<sub>2</sub>.

Alternatively, Crowcon can provide a calibration unit and calibration gas for checking and calibrating the sensors. The following sections describe the calibration procedure.

## 6.2 Fuses

There are two fuses fitted in CellarSafe. One fuse protects the AC inlet. The other 2A (anti-surge) fuse is on the PCB. If either fuse requires replacement, disconnect the unit from the mains power supply. Remove the four front-cover fixing screws and carefully take off the cover. Then replace the fuse that has failed with a fuse of identical specification.

## 6.3 Calibration

These instructions provide guidelines for the service engineer to calibrate the CellarSafe using the CellarSafe calibration unit (Figure 6.1). The calibration unit is suitable for all models of the CellarSafe gas monitoring system. Calibration

requires calibration gases and a pair of bayonet calibration adapters. In calibration mode all alarms and relays are inhibited.

### Calibration gases

Zero calibration is performed using 100% nitrogen. Span calibration is performed using a gas mixture comprising 4.0% carbon dioxide and 20.75% oxygen with a balance of nitrogen.

### Bayonet calibration adapters

A single pipe and bayonet fitting is provided for the CellarSafe carbon dioxide only monitoring system. The adapter for the CellarSafe carbon dioxide and oxygen monitoring system is supplied with a "T" junction and a single common supply pipe. The flow of the calibration gas should be set to 750 ml/min for the carbon dioxide only monitoring system, and 1.5 l/min for the dual gas monitoring system.

## 6.4 Calibrating the CellarSafe gas monitor

**Before connecting the Calibration Init, ensure all power to the base unit is off. This includes disconnecting the battery if fitted. Failure to do so will risk damage to the unit.**

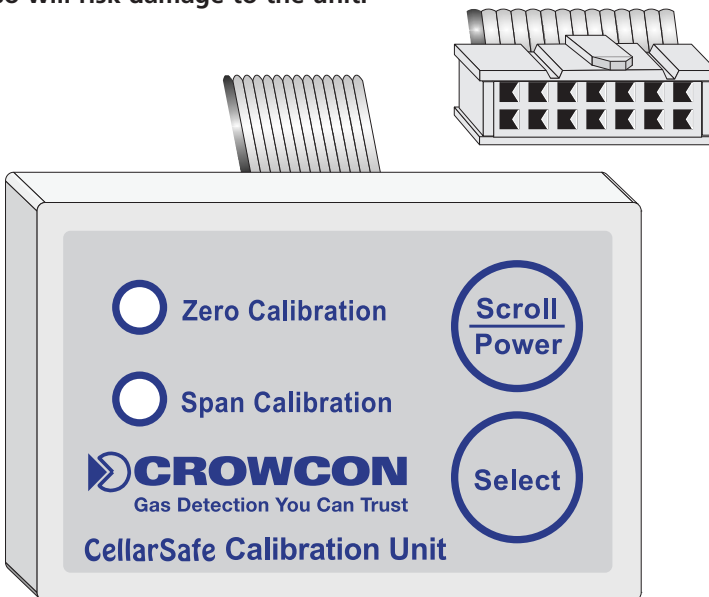

Figure 6.1 CellarSafe Calibration Unit

## Step 1:

### Connecting the Calibration Unit

- 1 Switch off the mains supply to the CellarSafe base unit and any ancillary equipment connected to the alarm relays.
- 2 Remove the front cover and disconnect the battery if fitted.
- 3 Plug the lead from the calibration unit into the connector marked "PL2" on the printed circuit board.
- 4 Replace the front panel of the CellarSafe base unit. Do not over-tighten the screws.
- 5 Reconnect the mains electrical supply.

**Allow the instrument to stabilise for a few minutes. It is essential the CellarSafe reaches the appropriate thermal equilibrium for the gas monitors to work correctly and for the calibration to be performed without error.**

*NOTE: In the unlikely event of a communication problem between the calibration unit and the base unit, both LEDs will flicker rapidly to alert the user. If this occurs, the system may be reset by disconnecting the mains electrical supply for a few seconds (the battery should already be disconnected) and re-applying the mains power.*

## Step 2:

### Connecting the zero calibration gas

*NOTE: zero gas calibration MUST BE performed before the span gas calibration.*

- 1 Insert the bayonet of the adapter into the sensor inlets by gently twisting clockwise until they snap into place.
- 2 Connect the other end of the adapter to the zero calibration gas (100% nitrogen).
- 3 Adjust the gas flow to 750 ml/min for the carbon dioxide only monitoring system and 1.5 ml/min for the dual gas monitoring system. Allow the system to stabilise for several minutes.

*NOTE: Once connected, the calibration unit can be switched on or off by pressing and holding the Scroll/Power button for 3 seconds.*

## Step 3:

### Calibrating zero gas

- 1 Press the Scroll/Power button to turn on the calibration unit. The Zero Calibration or the Span Calibration LED will illuminate.

The base unit is now in calibration mode, the operator display panel will display alternately the internal temperature of the instrument and the gas reading.

- 2 If the Zero Calibration LED is not lit, press the Scroll/Power button.
- 3 Apply zero calibration gas as described in step 2 above, and wait for the gas reading in the operator display panel to stabilise.
- 4 Press the Select button to start the calibration. The Zero Calibration LED will flash to indicate that calibration is in progress.

After approximately one minute the Zero Calibration LED will stop flashing and zero calibration is complete.

**NOTE:** The carbon dioxide reading will briefly indicate an error on the operator display panel for a few seconds immediately after a calibration has been performed. This is normal.

To abort the calibration for any reason press the Scroll/Power button.

- 5 Proceed to step 4 to calibrate the span gas.

## Step 4:

### Calibrating span gas

- 1 Connect the adapter to the span calibration gas.
  - 2 Adjust the gas flow to 750 ml/min for the carbon dioxide only monitoring system and 1.5 ml/min for the dual gas monitoring system. Allow the system to stabilise for several minutes.
  - 3 Press the Scroll/Power button to illuminate the Span calibration LED.
- The base unit is now in calibration mode, the operator display panel will display alternately the internal temperature of the instrument and the gas reading.
- 4 Apply span calibration gas and wait for the gas reading in the operator display panel to stabilise.
  - 5 Press the Select button to start the calibration. The Span Calibration LED will flash to indicate that calibration is in progress.

After approximately one minute the Span Calibration LED will stop flashing and span calibration is complete.

**NOTE:** The carbon dioxide reading will briefly indicate an error on the operator display panel for a few seconds immediately after a calibration has been performed. This is normal.

To abort the calibration for any reason press the Scroll/Power button.

- 6 Switch off the calibration unit by pressing the Scroll/Power button once, and then press and hold Scroll/Power button 3 seconds. Both LEDs will extinguish.

## **Step 5:**

### **Calibration Unit disconnection**

- 1 Press and hold Scroll/Power button for 3 seconds to switch off the mains electrical supply to the base unit.
- 2 Disconnect the bayonet calibration adapter if not already done so.
- 3 Remove the four screws securing the front panel of the Base Unit.
- 4 Unplug the lead from the calibration unit from the printed circuit board.
- 5 If fitted, plug the battery into the connector marked "PL1" on the printed circuit board.
- 6 Refit the front panel of the base unit. Do not over tighten the screws.
- 7 Reconnect the mains electrical supply to the base unit and relays (if fitted).

The CellarSafe will perform the start up routine and stabilise after 2 minutes.

This product has been tested and found to comply with the European Directive 89/336/EEC, the low voltage directive EN61010 and the EMC requirements of EN50270.





