

Operating instructions | EN

EL2904

TwinSAFE Terminal with 4 digital fail-safe outputs



Table of contents

1	Foreword	5
1.1	Notes on the documentation	5
1.2	Safety instructions	6
1.2.1	Delivery state	6
1.2.2	Operator's obligation to exercise diligence	6
1.2.3	Description of instructions	7
1.3	Documentation issue status	8
2	System description	10
2.1	The Beckhoff Bus Terminal system	10
2.1.1	Bus Coupler	11
2.1.2	Bus Terminals	12
2.1.3	E-bus	12
2.1.4	Power contacts	12
2.2	TwinSAFE	13
2.2.1	The I/O construction kit is extended safely	13
2.2.2	Safety concept	13
2.2.3	EL1904, EL2904 - Bus Terminals with 4 fail-safe inputs or outputs	14
2.2.4	EL6900 - TwinSAFE logic terminal	14
2.2.5	The fail-safe principle (Fail Stop)	14
3	Product description	15
3.1	EL2904 – TwinSAFE terminal with 4 digital fail-safe outputs	15
3.2	Intended use	16
3.3	Technical data	18
3.4	Safety parameters	19
3.5	Dimensions	20
3.6	Block diagram of the EL2904	21
4	Operation	22
4.1	Environmental conditions	22
4.2	Installation	22
4.2.1	Safety instructions	22
4.2.2	Transport / storage	22
4.2.3	Electrical installation	22
4.2.4	Mechanical installation	27
4.2.5	TwinSAFE reaction times	32
4.2.6	Tested EL2904 devices	33
4.3	Operation in potentially explosive atmospheres (ATEX)	34
4.3.1	Special conditions	34
4.3.2	Identification	34
4.3.3	Date code and serial number	35
4.3.4	Further ATEX documentation	35
4.4	Configuration of the terminal in TwinCAT	35
4.4.1	Inserting a Bus Coupler	35
4.4.2	Inserting a Bus Terminal	35

4.4.3	Inserting an EL2904.....	35
4.4.4	Address settings on TwinSAFE terminals with 1023 possible addresses	37
4.4.5	Entering a TwinSAFE address and parameters in the System Manager	38
4.5	Diagnostics	40
4.5.1	Diagnostic LEDs	40
4.5.2	Diagnostic objects.....	41
4.5.3	Possible causes of diagnostic messages	43
4.6	Maintenance	44
4.7	Service life	44
4.8	Decommissioning	45
5	Appendix	46
5.1	Support and Service	46
5.2	Certificates.....	47

1 Foreword

1.1 Notes on the documentation

Intended audience

This description is only intended for the use of trained specialists in control and automation engineering who are familiar with the applicable national standards.

It is essential that the following notes and explanations are followed when installing and commissioning these components.

The responsible staff must ensure that the application or use of the products described satisfy all the requirements for safety, including all the relevant laws, regulations, guidelines and standards.

Origin of the document

This is a translation of the original instructions which are written in German. All other languages are derived from the German original.

Currentness

Please check whether you are using the current and valid version of this document. The current version can be downloaded from the Beckhoff homepage at <https://www.beckhoff.com/twinsafe/>. In case of doubt, please contact Technical [Support](#) [► 46].

Product features

Only the product features specified in the current user documentation are valid. Further information given on the product pages of the Beckhoff homepage, in emails or in other publications is not authoritative.

Disclaimer

The documentation has been prepared with care. The products described are subject to cyclical revision. For that reason the documentation is not in every case checked for consistency with performance data, standards or other characteristics. We reserve the right to revise and change the documentation at any time and without prior announcement. No claims for the modification of products that have already been supplied may be made on the basis of the data, diagrams and descriptions in this documentation.

Trademarks

Beckhoff®, TwinCAT®, TwinCAT/BSD®, TC/BSD®, EtherCAT®, EtherCAT G®, EtherCAT G10®, EtherCAT P®, Safety over EtherCAT®, TwinSAFE®, XFC®, XTS® and XPlanar® are registered trademarks of and licensed by Beckhoff Automation GmbH. Other designations used in this publication may be trademarks whose use by third parties for their own purposes could violate the rights of the owners.

Patent Pending

The EtherCAT Technology is covered, including but not limited to the following patent applications and patents: EP1590927, EP1789857, EP1456722, EP2137893, DE102015105702 with corresponding applications or registrations in various other countries.



EtherCAT® and Safety over EtherCAT® are registered trademarks and patented technologies, licensed by Beckhoff Automation GmbH, Germany.

Copyright

© Beckhoff Automation GmbH & Co. KG, Germany.

The reproduction, distribution and utilization of this document as well as the communication of its contents to others without express authorization are prohibited.

Offenders will be held liable for the payment of damages. All rights reserved in the event of the grant of a patent, utility model or design.

Delivery conditions

In addition, the general delivery conditions of the company Beckhoff Automation GmbH & Co. KG apply.

1.2 Safety instructions

1.2.1 Delivery state

All the components are supplied in particular hardware and software configurations appropriate for the application. Modifications to hardware or software configurations other than those described in the documentation are not permitted, and nullify the liability of Beckhoff Automation GmbH & Co. KG.

1.2.2 Operator's obligation to exercise diligence

The operator must ensure that

- the TwinSAFE products are only used as intended (see chapter Product description);
- the TwinSAFE products are only operated in sound condition and in working order.
- the TwinSAFE products are operated only by suitably qualified and authorized personnel.
- the personnel is instructed regularly about relevant occupational safety and environmental protection aspects, and is familiar with the operating instructions and in particular the safety instructions contained herein.
- the operating instructions are in good condition and complete, and always available for reference at the location where the TwinSAFE products are used.
- none of the safety and warning notes attached to the TwinSAFE products are removed, and all notes remain legible.

1.2.3 Description of instructions

In these operating instructions the following instructions are used.
These instructions must be read carefully and followed without fail!

DANGER

Serious risk of injury!

Failure to follow this safety instruction directly endangers the life and health of persons.

WARNING

Risk of injury!

Failure to follow this safety instruction endangers the life and health of persons.

CAUTION

Personal injuries!

Failure to follow this safety instruction can lead to injuries to persons.

NOTE

Damage to the environment/equipment or data loss

Failure to follow this instruction can lead to environmental damage, equipment damage or data loss.



Tip or pointer

This symbol indicates information that contributes to better understanding.

1.3 Documentation issue status

Version	Comment
2.3.0	<ul style="list-style-type: none"> Utilization category added Intended load added Overvoltage category added Protection class added Equipment type "open equipment" added "Level of contamination" replaced by "pollution degree" Chapter "Intended use": "may" replaced by "shall" Currentness link updated Document origin: description changed
2.2.0	<ul style="list-style-type: none"> Notes on heights, fuses and wiring added Notes on EN 81 added Notes added in section <i>Intended Use</i> Chapter <i>Identification (ATEX)</i> updated
2.1.1	<ul style="list-style-type: none"> Technical data for <i>permissible air pressure</i> expanded
2.1.0	<ul style="list-style-type: none"> Chapter on <i>Address settings on TwinSAFE terminals with 1023 possible addresses</i> updated Links in technical data corrected
2.0.1	<ul style="list-style-type: none"> Links in the chapter on <i>Diagnostic LEDs</i> corrected
2.0.0	<ul style="list-style-type: none"> Migration and structural adaptation Reliability document updated Safety parameters updated Foreword revised
1.6.2	<ul style="list-style-type: none"> Block diagram updated Numbering/table of contents changed Description of the reaction times added Reliability document updated
1.6.1	<ul style="list-style-type: none"> Certificate updated
1.6.0	<ul style="list-style-type: none"> Company address amended Safety parameters extended
1.5.0	<ul style="list-style-type: none"> Extended temperature range amended Notes regarding temperature measurement and EMC added Description of date code extended
1.4.1	<ul style="list-style-type: none"> Document origin added
1.4.0	<ul style="list-style-type: none"> Note regarding cable length and signal routing extended Table listing causes for diagnostic messages amended
1.3.0	<ul style="list-style-type: none"> Block diagram for EL2904 added
1.2.1	<ul style="list-style-type: none"> Reference to EN 60068-2-29 removed
1.2.0	<ul style="list-style-type: none"> ATEX notes amended Installation position / minimum distances extended Notes regarding overvoltage protection amended Notes regarding cable length and clocked signals extended EN954 wiring example removed Diagnostics for CoE object 0x800E described
1.1.0	<ul style="list-style-type: none"> Minor amendments for EtherCAT Copyright / disclaimer modified Support / service addresses updated
1.0.0	<ul style="list-style-type: none"> First released version

2 System description

2.1 The Beckhoff Bus Terminal system

The Beckhoff Bus Terminal system is used for decentralized connection of sensors and actuators to a control system. The Beckhoff Bus Terminal system components are mainly used in industrial automation and building management applications. In its minimum configuration, a bus station consists of a Bus Coupler or a Bus Terminal Controller and Bus Terminals connected to it. The Bus Coupler forms the communication interface to the higher-level controller, and the terminals are the interface to sensors and actuators. The whole bus station is clipped onto a 35 mm DIN mounting rail (EN 60715). The mechanical cross connection of the bus station is established via a slot and key system at the Bus Coupler and the Bus Terminals.

The sensors and actuators are connected with the terminals via the screwless (spring-loaded) connection system.

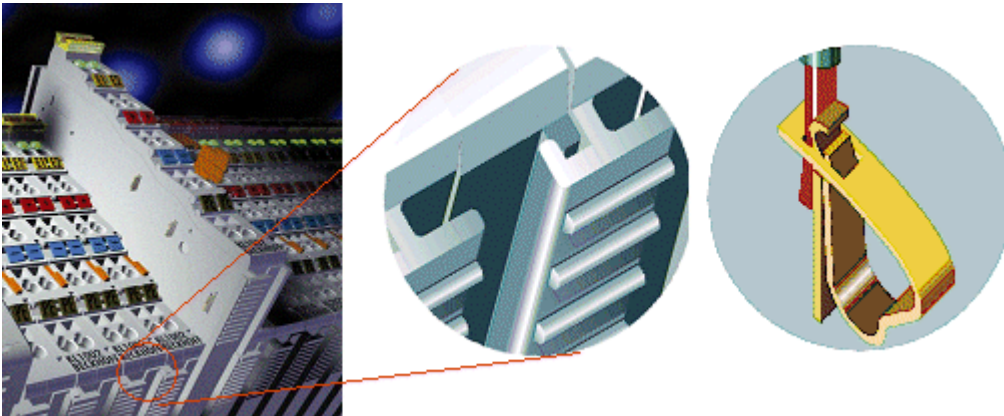

Fig. 1: Slot and key system and screwless (spring-loaded) connection system.

In order to accommodate the wide range of different communication standards encountered in industrial automation, Beckhoff offers Bus Couplers for a number of common bus systems (e.g. EK1100 for EtherCAT).

2.1.1 Bus Coupler

Mechanical data	Bus Coupler
Material	polycarbonate, polyamide (PA6.6).
Dimensions (W x H x D)	44 mm x 100 mm x 68 mm
Mounting	on 35 mm mounting rail (EN 60715) with locking
Attachable by	double slot and key connection

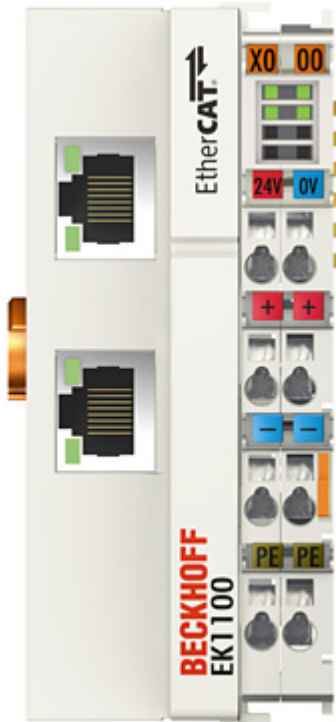

Fig. 2: Bus Coupler (EtherCAT)

Connection technology	Bus Coupler
Wiring	spring-loaded system
Connection cross-section	0.08 mm ² ... 2.5 mm ² , stranded wire, solid wire
Fieldbus connection	depending on fieldbus
Power contacts	3 spring contacts
Current load	10 A
Rated voltage	24 V _{DC}

2.1.2 Bus Terminals

Mechanical data	Bus Terminal
Material	polycarbonate, polyamide (PA6.6).
Dimensions (W x H x D)	12 mm x 100 mm x 68 mm or 24 mm x 100 mm x 68 mm
Mounting	on 35 mm mounting rail (EN 60715) with locking
Attachable by	double slot and key connection

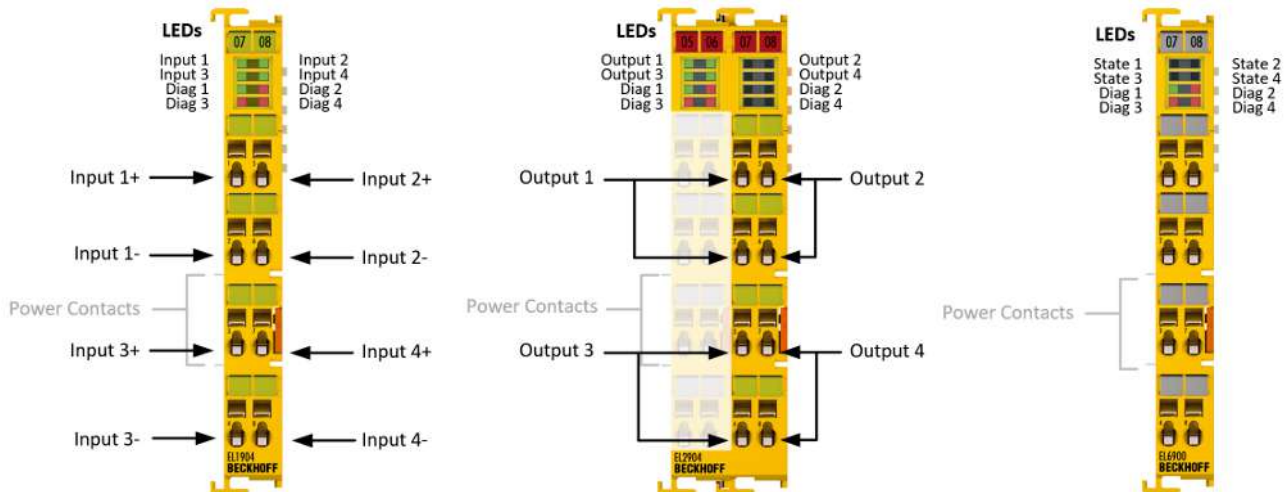

Fig. 3: TwinSAFE Terminals (EtherCAT)

Connection technology	Bus Terminal
Wiring	spring-loaded system
Connection cross-section	0.08 mm ² ... 2.5 mm ² , stranded wire, solid wire
Fieldbus connection	E-bus
Power contacts	up to 3 blade/spring contacts
Current load	10 A
Rated voltage	depends on Bus Terminal type

2.1.3 E-bus

The E-bus is the data path within a terminal strip. The E-bus is led through from the Bus Coupler through all the terminals via six contacts on the terminals' side walls.

2.1.4 Power contacts

The operating voltage is passed on to following terminals via three power contacts. Terminal strip can be split into galvanically isolated groups by means of potential feed terminals as required. The power feed terminals play no part in the control of the terminals, and can be inserted at any locations within the terminal strip.

2.2 TwinSAFE

2.2.1 The I/O construction kit is extended safely

With the TwinSAFE Terminals, Beckhoff offers the option of simply expanding the proven Bus Terminal system, and to transfer the complete cabling for the safety circuit into the already existing fieldbus cable. Safe signals can be mixed with standard signals without restriction. This saves design effort, installation and material. Maintenance is simplified significantly through faster diagnosis and simple replacement of only a few components.

The new ELx9xx series Bus Terminals only include three basic functionalities: digital inputs EL19xx, digital outputs EL29xx and a logic unit EL6900. For a large number of applications, all sensors and actuators can be wired on these Bus Terminals. The required logical link of the inputs and the outputs is handled by the EL6900. For small to medium-sized configurations, the tasks of a fail-safe PLC can thus be handled within the Bus Terminal system.

2.2.2 Safety concept

TwinSAFE: Safety and I/O technology in one system

- Extension of the familiar Beckhoff I/O system with TwinSAFE terminals
- Freely selectable mix of safe and standard signals
- Logical link of the I/Os in the EL6900 TwinSAFE logic terminal
- Safety-relevant networking of machines via bus systems

TwinSAFE protocol (FSoE)

- Transfer of safety-relevant data via any media (“genuine black channel”)
- TwinSAFE communication via fieldbus systems such as EtherCAT, Lightbus, PROFIBUS or Ethernet
- IEC 61508:2010 SIL 3 compliant

Configuring instead of wiring: the TwinSAFE configurator

- Configuration of the TwinSAFE system via the TwinCAT System Manager
- System Manager for editing and displaying all bus parameters
- Certified function blocks such as emergency stop, operation mode, etc.
- Simple handling
- Typical function blocks for machine safety
- any bus connection with the EL6900 TwinSAFE logic terminal

TwinSAFE logic Bus Terminal EL6900

- Link unit between TwinSAFE input and output terminals
- Configuration of a simple, flexible, cost-effective, decentralized safety controller
- No safety requirements for higher-level control system
- TwinSAFE enables networks with up to 65535 TwinSAFE devices.
- TwinSAFE Logic Terminal can establish up to 128 connections (TwinSAFE connections).
- Several TwinSAFE Logic Terminals are cascadable in a network
- Safety functions such as emergency stop, protective door, etc. are already included
- Suitable for applications up to SIL 3 according to IEC 61508:2010 and DIN EN ISO 13849-1:2015 (Cat 4, PL e).

TwinSAFE digital input (EL1904) and output terminal (EL2904)

- All current safety sensors can be connected
- Operation with a TwinSAFE logic terminal
- EL1904 with 4 fail-safe inputs for sensors (24 VDC) with potential-free contacts
- EL2904 with four safe channels for actuators (24 VDC, 0.5 A per channel)
- Conforming to IEC 61508:2010 SIL 3 and EN ISO 13849-1:2015 (Cat 4, PL e) requirements.

2.2.3 EL1904, EL2904 - Bus Terminals with 4 fail-safe inputs or outputs

The EL1904 and EL2904 Bus Terminals enable connection of common safety sensors and actuators. They are operated with the EL6900 TwinSAFE logic terminal. The TwinSAFE logic terminal is the link unit between the TwinSAFE input and output terminals. It enables the configuration of a simple, flexible and cost-effective decentralized safety control system.

Therefore, there are no safety requirements for the higher-level controller! The typical safety functions required for the automation of machines, such as emergency stop, protective door, two-hand etc., are already permanently programmed in the EL6900. The user configures the EL6900 terminal according to the safety requirements of his application.

2.2.4 EL6900 - TwinSAFE logic terminal

The TwinSAFE Logic Terminal is the link unit between the TwinSAFE input and output terminals. The EL6900 meets the requirements of IEC 61508:2010 SIL 3 and EN ISO 13849-1:2015 (Cat 4, PL e).

2.2.5 The fail-safe principle (Fail Stop)

The basic rule for a safety system such as TwinSAFE is that failure of a part, a system component or the overall system must never lead to a dangerous condition. The safe state is always the switched off and wattless state.

3 Product description

3.1 EL2904 – TwinSAFE terminal with 4 digital fail-safe outputs

The EL2904 is a safe output terminal with digital outputs for connecting actuators (contactors, relays, etc.) with a maximum current 0.5 A (24 V_{DC}). The Bus Terminal has 4 fail-safe outputs.

The EL2904 meets the requirements of IEC 61508:2010 SIL 3, EN ISO 13849-1:2015 (Cat 4, PL e), NRTL, UL508, UL1998 and UL991.

The TwinSAFE terminal has the typical design of an EtherCAT terminal.

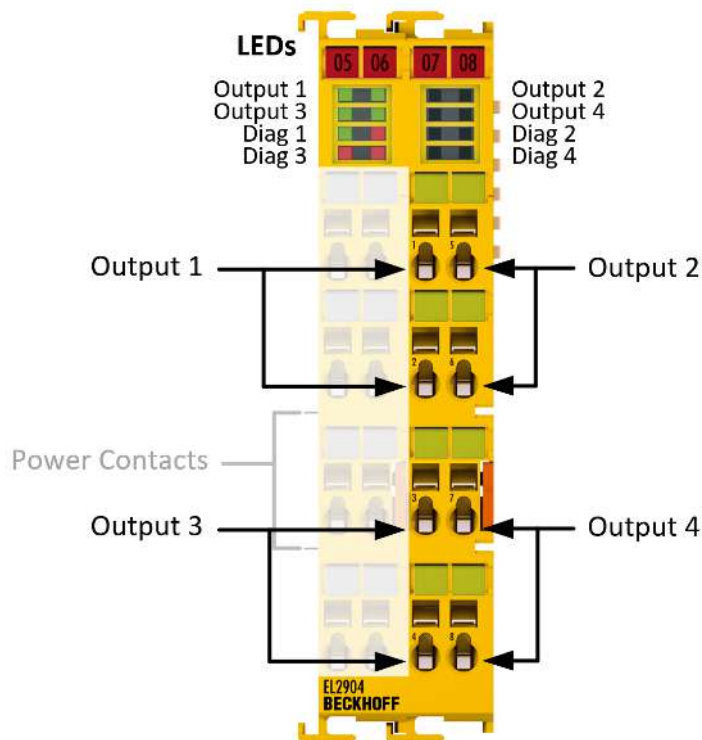

Fig. 4: EL2904 – TwinSAFE terminal with 4 digital fail-safe outputs

3.2 Intended use

⚠ WARNING

Caution - Risk of injury!

TwinSAFE components shall only be used for the purposes described below!

The TwinSAFE terminals expand the application range of Beckhoff Bus Terminal system with functions that enable them to be used for machine safety applications. The TwinSAFE terminals are designed for machine safety functions and directly associated industrial automation tasks. They are therefore only approved for applications with a defined fail-safe state. This safe state is the wattless state. Fail-safety according to the relevant standards is required.

The TwinSAFE Terminals enable connection of:

- 24 V_{DC} sensors (EL1904) such as emergency off pushbutton switches, pull cord switches, position switches, two-hand switches, safety mats, light curtains, light barriers, laser scanner, etc.
- 24 V_{DC} actuators (EL2904) such as contactors, protection door switches with tumbler, signal lamps, servo drives, etc.

● Test pulses



When selecting actuators please ensure that the EL2904 test pulses do not lead to actuator switching or diagnostic message from the EL2904.

The following TwinSAFE components have been developed for these tasks:

- The EL1904 is an EtherCAT Terminal with 4 digital fail-safe inputs.
- The EL2904 is an EtherCAT Terminal with 4 digital fail-safe outputs.
- The EL6900 is an EtherCAT Terminal with integrated TwinSAFE logic.

These TwinSAFE components are suitable for operation on the

- Beckhoff EKxxxx series Bus Couplers
- Beckhoff CXxxxx series Embedded PCs with E-bus connection

⚠ WARNING

Power supply from SELV/PELV power supply unit!

The TwinSAFE components must be supplied with 24 V_{DC} by an SELV/PELV power supply unit with an output voltage limit U_{max} of 36 V_{DC} . Failure to observe this can result in a loss of safety.

⚠ CAUTION

Follow the machinery directive!

The TwinSAFE components shall only be used in machines as defined in the machinery directive.

⚠ CAUTION

Ensure traceability!

The buyer has to ensure the traceability of the device via the serial number.

⚠ WARNING

Commissioning test

Before the EL1904/EL2904 can be used for the safety task, the user must carry out a commissioning test so that sensor and actuator wiring errors can be ruled out.

⚠ CAUTION

Use ferrules with plastic collars

When using fine-wire cables for signal connections, use ferrules with plastic collars. This leads to a higher system availability when the test pulses for the corresponding channels are switched off.

⚠ CAUTION**Note on approval according to EN 81-20, EN 81-22 and EN 81-50**

- The TwinSAFE components shall only be used in machines that have been designed and installed in accordance with the requirements of the EN 60204-1 standard.
- Provide a surge filter for the supply voltage of the TwinSAFE components against overvoltages. (Reduction to overvoltage category II)
- EN 81 requires that in the case of devices with internal temperature monitoring, a stop must be reached in the event of an overtemperature. In this case, passengers must be able to disembark (see EN 81-20 chapter 5.10.4.3, for example). To ensure this, application measures are necessary. The internal terminal temperature of the TwinSAFE components can be read out by the user. There is a direct switch-off at the maximum permissible temperature of the respective TwinSAFE component (see chapter Temperature measurement).
The user must select a temperature threshold below the maximum temperature such that a stop can be reached in all cases before the maximum temperature is reached. Information on the optimum terminal configuration can be found under Notes on the arrangement of TwinSAFE components and under Example configuration for temperature measurement.
- For the use of the TwinSAFE components according to EN 81-22 and EN 81-50, the conditions described in the manuals for achieving category 4 according to EN ISO 13849-1:2015 **must be** observed.
- The use of TwinSAFE components is limited to indoor applications.
- Basic protection against direct contact must be provided, either by fulfilling protection class IP2X or by installing the TwinSAFE components in a control cabinet which corresponds at least to protection class IP54 according to EN 60529.
- The ambient conditions regarding temperature, humidity, heat dissipation, EMC and vibrations, as specified in the operating instructions under technical data, must be observed.
- The operating conditions in potentially explosive atmospheres (ATEX) are specified in the operating instructions.
- The safe state (triggering) of the application must be the de-energized state. The safe state of the TwinSAFE components is always the de-energized, switched-off state, and this cannot be changed.
- The service life specified in the operating instructions must be observed.
- If the TwinSAFE component is operated outside the permissible temperature range, it changes to "Global Shutdown" state.
- The TwinSAFE components must be installed in a control cabinet with protection class IP54 according to EN 60529, so that the requirement for pollution degree 3 according to EN 60664-1 can be reduced to level 2.
- The TwinSAFE components must be supplied by a SELV/PELV power supply unit with a maximum voltage of $U_{\max} \leq 36 \text{ V}_{\text{DC}}$.

3.3 Technical data

Product designation	EL2904
Number of outputs	4
Status display	4 (one green LED per output)
Fault reaction time	≤ watchdog times
Output current per channel	max. 500 mA, min. 20 mA with <i>Current Measurement Active</i> parameter enabled
Utilization category according to EN 60947-5-1	DC-13
Intended load	Pilot Duty
Actuators	When selecting actuators please ensure that the EL2904 test pulses do not lead to actuator switching.
Cable length between actuator and terminal	unshielded max. 100 m shielded max. 100 m
Wire cross-section	min. 0.75 mm ²
Input process image	6 bytes
Output process image	6 bytes
EL2904 supply voltage (PELV)	24 V _{DC} (-15% / +20%) (A 10 A fuse should be provided for the potential group)
Protection class	III (by using a SELV/PELV power supply unit)
Overvoltage category	II
Current consumption via E-bus	approx. 221 mA
Power dissipation of the terminal	typically 2 W
Electrical isolation (between the channels)	no
Electrical isolation (between the channels and the E-bus)	yes
Insulation voltage (between the channels and the E-bus, under common operating conditions)	Insulation tested with 500 V _{DC}
Dimensions (W x H x D)	24 mm x 100 mm x 68 mm
Weight	approx. 100 g
Permissible ambient temperature (operation) up to SW 03	0°C to +55°C (see notes in chapter Example configuration for temperature measurement)
Permissible ambient temperature (operation) from SW 04 (CW 02/2014)	-25°C to +55°C (see notes in section Example configuration for temperature measurement)
Permissible ambient temperature (transport/storage)	-40 °C to +70 °C
Permissible air humidity	5% to 95%, non-condensing
Permissible air pressure (operation/storage/transport)	750 hPa to 1100 hPa (this corresponds to an altitude of approx. -690 m to 2450 m above sea level, assuming an international standard atmosphere)
Climate category according to EN 60721-3-3	3K3 (the deviation from 3K3 is possible only with optimal environmental conditions and also applies only to the technical data which are specified differently in this documentation)
Permissible pollution degree according to EN 60664-1	2 (note chapter Maintenance [▶ 44])
Inadmissible operating conditions	TwinSAFE Terminals must not be used under the following operating conditions: <ul style="list-style-type: none"> • under the influence of ionizing radiation (exceeding the natural background radiation) • in corrosive environments • in an environment that leads to unacceptable soiling of the Bus Terminal
EMC immunity / emission	conforms to EN 61000-6-2 / EN 61000-6-4
Vibration / shock resistance	conforms to EN 60068-2-6 / EN 60068-2-27
Shocks	15 g with pulse duration 11 ms in all three axes
Protection class	IP20
Equipment type according to EN 61010-2-201	Open equipment
Permitted operating environment	In the control cabinet or terminal box, with minimum protection class IP54 according to IEC 60529
Correct installation position	see chapter Installation position and minimum distances
Approvals	CE, cULus, ATEX, TÜV SÜD

Derating table for altitudes above 2000 m

The derating table (table 8) from the IEC 61131-2:2017 standard can be referred to for the use of the TwinSAFE components above the specified maximum altitude.

Altitude in m	Derating factor for the temperature ¹
0 to 2000 ²	1.0
3000	0.9
4000	0.8
5000	0.7

Note: Linear interpolation is permissible between the altitudes

¹) Ambient temperature of the device at an altitude of 2000 m

²) The air pressure and air density increase as the altitude decreases. Therefore the derating factor for 0 to 2000 m (1.0) is used for altitudes below sea level.

Calculation example

In the following example the calculation is performed for a TwinSAFE component at an operating altitude of 4000 m.

Permissible ambient temperature up to 2000 m above sea level = 55 °C

Permissible ambient temperature up to 4000 m above sea level = 55 °C * 0.8 = **44 °C**

⚠ CAUTION

Compliance with the temperature limits

The TwinSAFE component has a maximum internal temperature at which a switch-off takes place. This is designed for the maximum permissible ambient temperature. If the derating factor for the temperature for higher altitudes is used, the user is solely responsible for ensuring that the calculated maximum ambient temperature is complied with.

3.4 Safety parameters

Characteristic numbers	EL2904
Lifetime [a]	20
Proof test Interval [a]	not required ¹
PFH _D	1.25E-09
%SIL3	1.25 %
PFD	8.45E-05
%SIL3	8.45 %
MTTF _d	high
DC	high
Performance level	PL e
Category	4
HFT	1
Element classification ²	Type B

1. Special proof tests are not required during the entire service life of the EL2904 EtherCAT terminal.
2. Classification according to IEC 61508-2:2010 (chapter 7.4.4.1.2 and 7.4.4.1.3)

The EL2904 EtherCAT Terminal can be used for safety-related applications within the meaning of IEC 61508:2010 up to SIL3 and EN ISO 13849-1:2015 up to PL e (Cat4).

For the calculation or estimation of the MTTF_d value from the PFH_D value, further information can be found in the TwinSAFE Application Guide or in ISO 13849-1:2015 Table K.1.

3.5 Dimensions

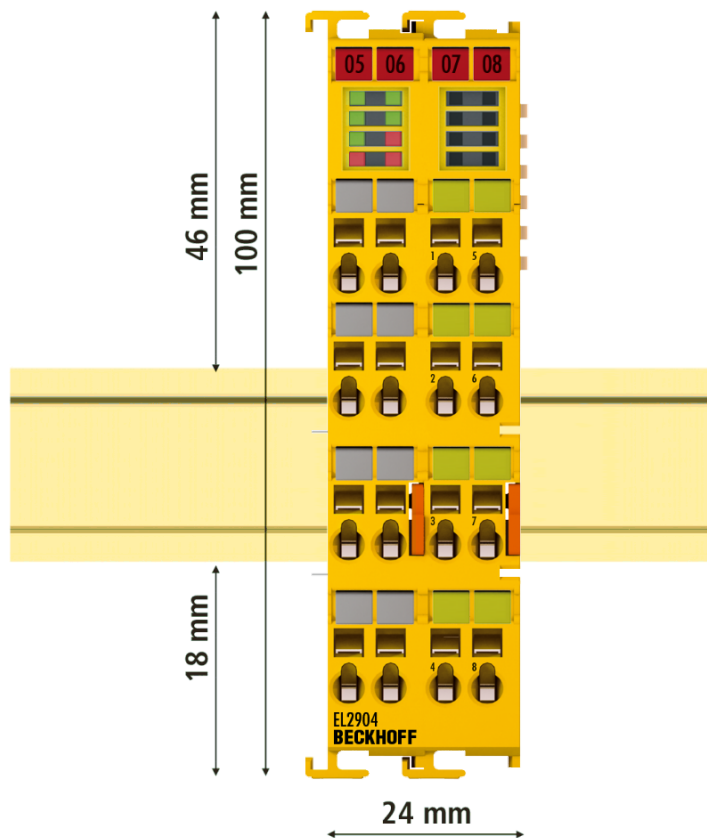

Fig. 5: Dimensions of the EL2904

Width: 24 mm (side-by-side installation)

Height: 100 mm

Depth: 68 mm

3.6 Block diagram of the EL2904

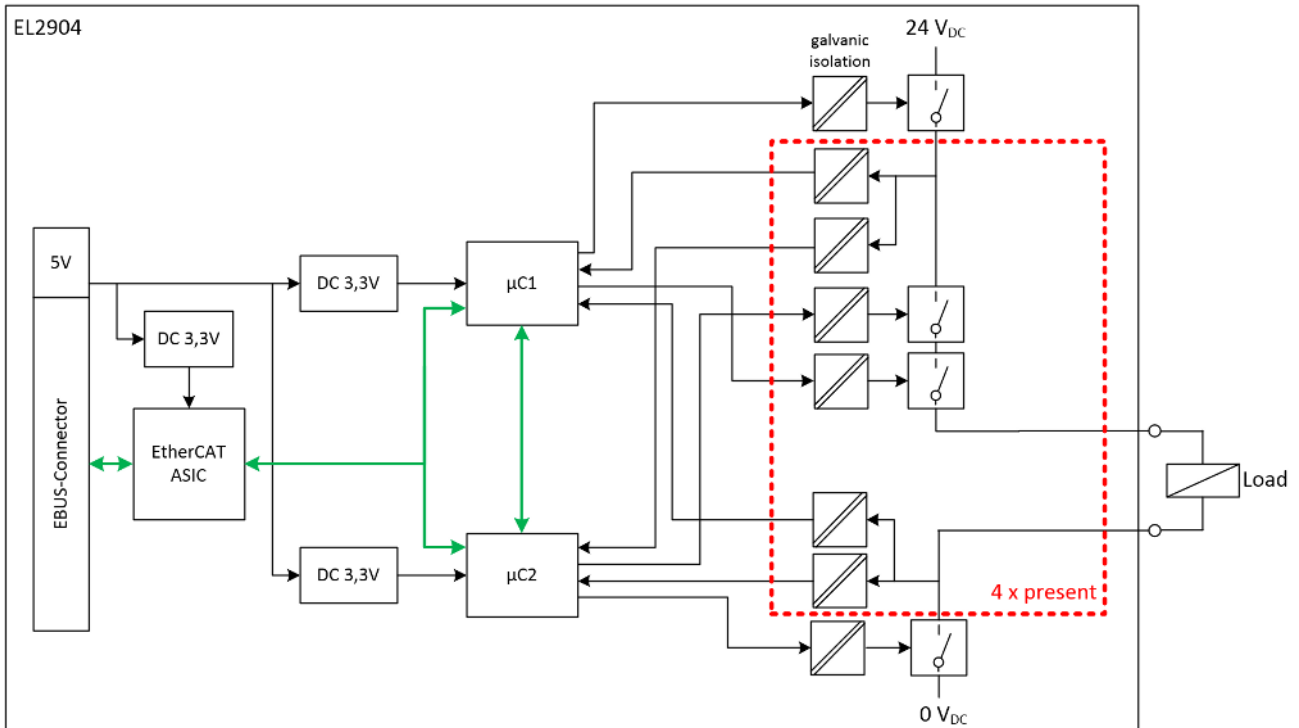

Fig. 6: Block diagram of the EL2904

The block diagram shows the basic configuration of a channel in the EL2904. The part with a red border is present four times in the terminal. The high-side and low-side switches only exist once for all channels. This means that each channel has a total of four stop paths.

4 Operation

4.1 Environmental conditions

Please ensure that the TwinSAFE components are only transported, stored and operated under the specified conditions (see technical data)!

WARNING

Risk of injury!

The TwinSAFE components must not be used under the following operating conditions.

- under the influence of ionizing radiation (that exceeds the level of the natural environmental radiation)
- in corrosive environments
- in an environment that leads to unacceptable soiling of the TwinSAFE component

NOTE

Electromagnetic compatibility

The TwinSAFE components comply with the current standards on electromagnetic compatibility with regard to spurious radiation and immunity to interference in particular.

However, in cases where devices such as mobile phones, radio equipment, transmitters or high-frequency systems that exceed the interference emissions limits specified in the standards are operated near TwinSAFE components, the function of the TwinSAFE components may be impaired.

4.2 Installation

4.2.1 Safety instructions

Before installing and commissioning the TwinSAFE components please read the safety instructions in the foreword of this documentation.

4.2.2 Transport / storage

Use the original packaging in which the components were delivered for transporting and storing the TwinSAFE components.

CAUTION

Note the specified environmental conditions

Please ensure that the digital TwinSAFE components are only transported and stored under the specified environmental conditions (see technical data).

4.2.3 Electrical installation

4.2.3.1 Connections within a Bus Terminal block

The electric connections between the Bus Coupler and the Bus Terminals are automatically realized by joining the components:

Spring contacts (E-bus)

The six spring contacts of the E-bus deal with the transfer of the data and the supply of the Bus Terminal electronics.

NOTE

Observe the E-bus current

Observe the maximum current that your Bus Coupler can supply to the E-bus! Use the EL9410 Power Supply Terminal if the current consumption of your terminals exceeds the maximum current that your Bus Coupler can feed to the E-bus supply.

Power contacts

The power contacts deal with the supply for the field electronics and thus represent a supply rail within the Bus Terminal block. The power contacts are supplied via terminals on the Bus Coupler.

● Note the connection of the power contacts

i During the design of a Bus Terminal block, the pin assignment of the individual Bus Terminals must be taken account of, since some types (e.g. analog Bus Terminals or digital 4-channel Bus Terminals) do not or not fully loop through the power contacts. Potential supply terminals (EL91xx, EL92xx) interrupt the power contacts and thus represent the start of a new supply rail.

PE power contact

The power contact labelled PE can be used as a protective earth. For safety reasons this contact mates first when plugging together, and can ground short-circuit currents of up to 125 A.

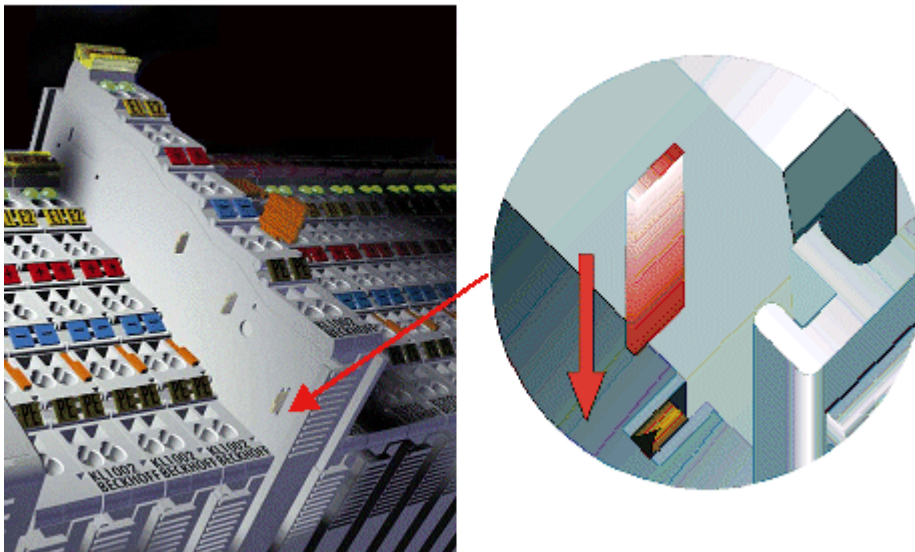

Fig. 7: PE power contact

⚠ CAUTION

Insulation tests

Note that, for reasons of electromagnetic compatibility, the PE contacts are capacitatively coupled to the mounting rail. This may lead to incorrect results during insulation testing or to damage on the terminal (e.g. disruptive discharge to the PE line during insulation testing of a consumer with a rated voltage of 230 V). For insulation testing, disconnect the PE supply line at the Bus Coupler or the Potential Supply Terminal! In order to decouple further feed points for testing, these Power Feed Terminals can be released and pulled at least 10 mm from the group of terminals.

⚠ DANGER

Serious risk of injury!

The PE power contact must not be used for other potentials!

4.2.3.2 Overvoltage protection

If protection against overvoltage is necessary in your plant, provide a surge filter for the voltage supply to the Bus Terminal blocks and the TwinSAFE terminals.

4.2.3.3 Wiring

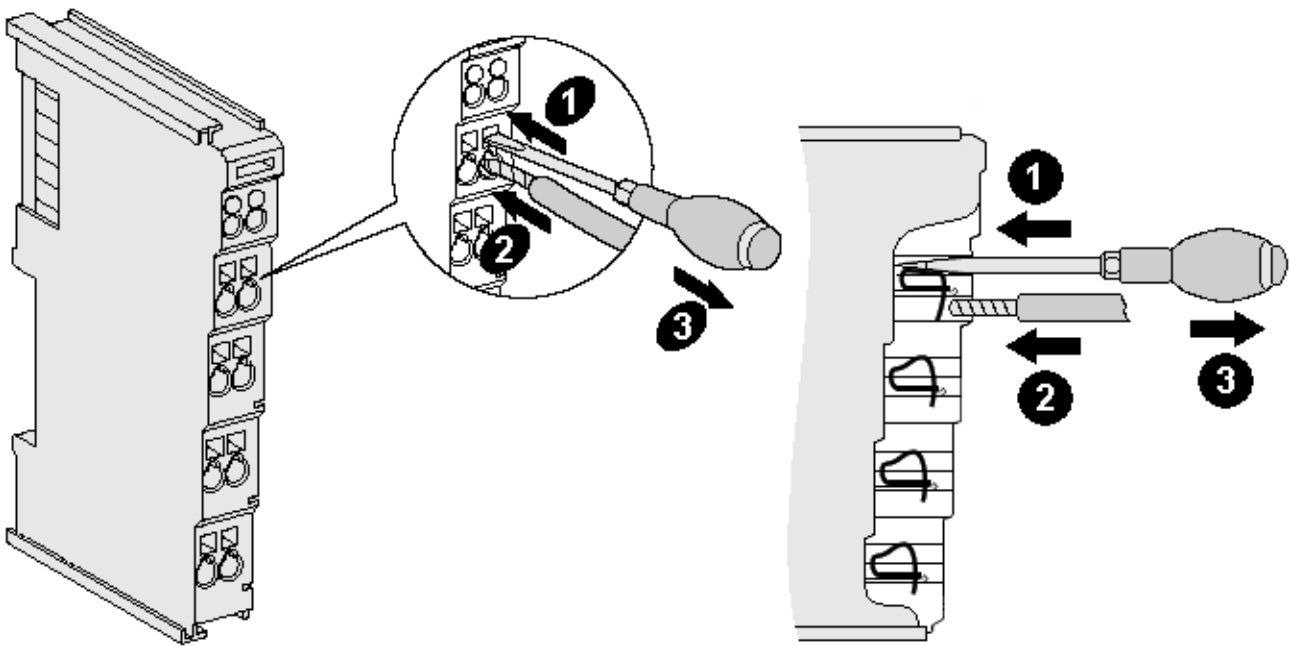

Fig. 8: Connection of a cable to a terminal point

Up to eight terminal points enable the connection of solid or finely stranded cables to the Bus Terminal. The terminal points are implemented in spring force technology. Connect the cables as follows:

1. Open a terminal point by pushing a screwdriver straight against the stop into the square opening above the terminal point. Do not turn the screwdriver or move it alternately (don't toggle).
2. The wire can now be inserted into the round terminal opening without any force.
3. The terminal closes automatically when the pressure is released, holding the wire safely and permanently.

See the following table for the suitable wire size width.

Wire size width (single core wires)	0.08 ... 2.5 mm ²
Wire size width (fine-wire conductors)	0.08 ... 2.5 mm ²
Wire size width (conductors with a wire end sleeve)	0.14 ... 1.5 mm ²
Wire stripping length	8 ... 9 mm

4.2.3.4 EL2904 pin assignment

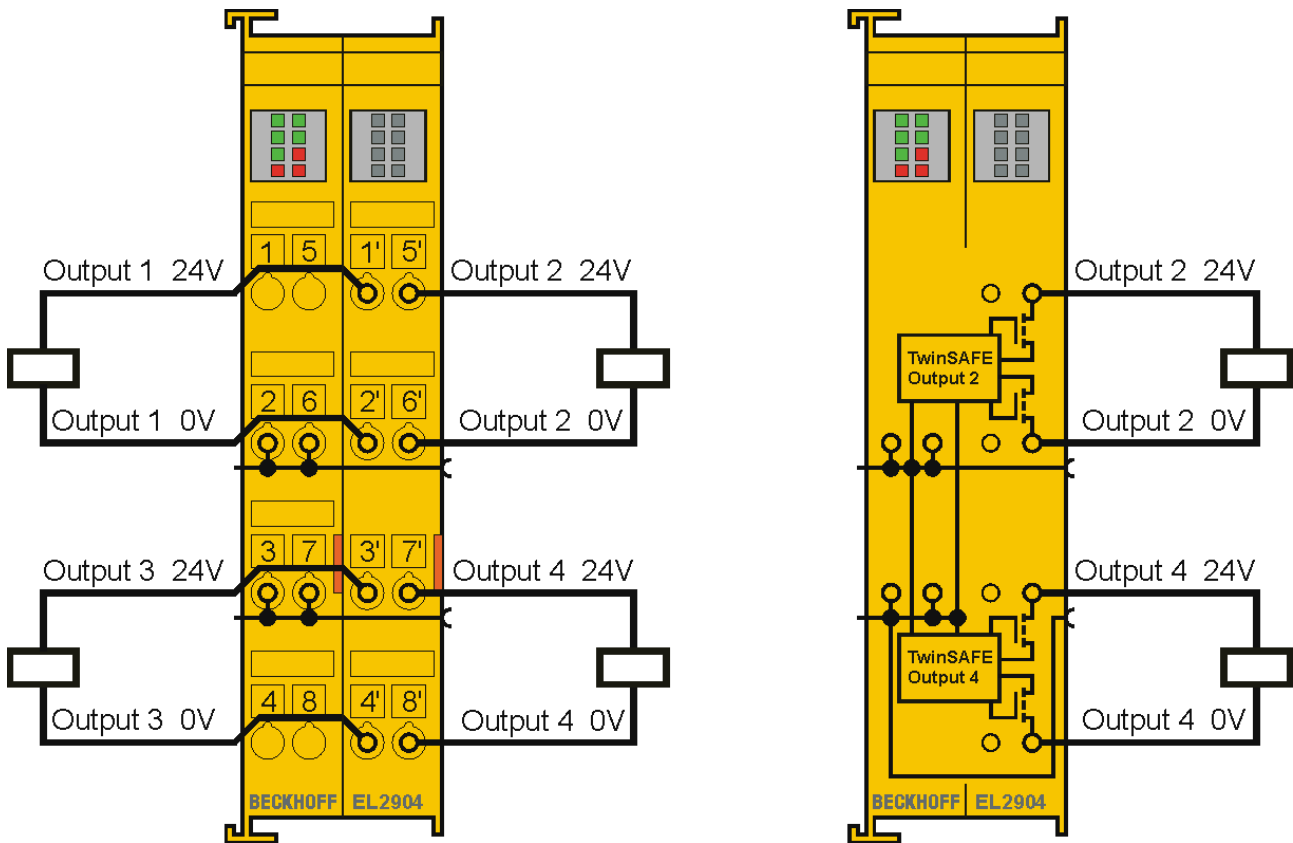

Fig. 9: EL2904 pin assignment

Terminal point	Output	Signal
1	-	not used, no function
2	-	positive power contact
3	-	negative power contact
4	-	not used, no function
5	-	not used, no function
6	-	positive power contact
7	-	negative power contact
8	-	not used, no function
1'	1	Output 1+
2'		Output 1-
3'	3	Output 3+
4'		Output 3-
5'	2	Output 2+
6'		Output 2-
7'	4	Output 4+
8'		Output 4-

i Test pulses

When selecting actuators please ensure that the EL2904 test pulses do not lead to actuator switching or diagnostic message from the EL2904.

4.2.3.5 Signal cables

Permitted cable length

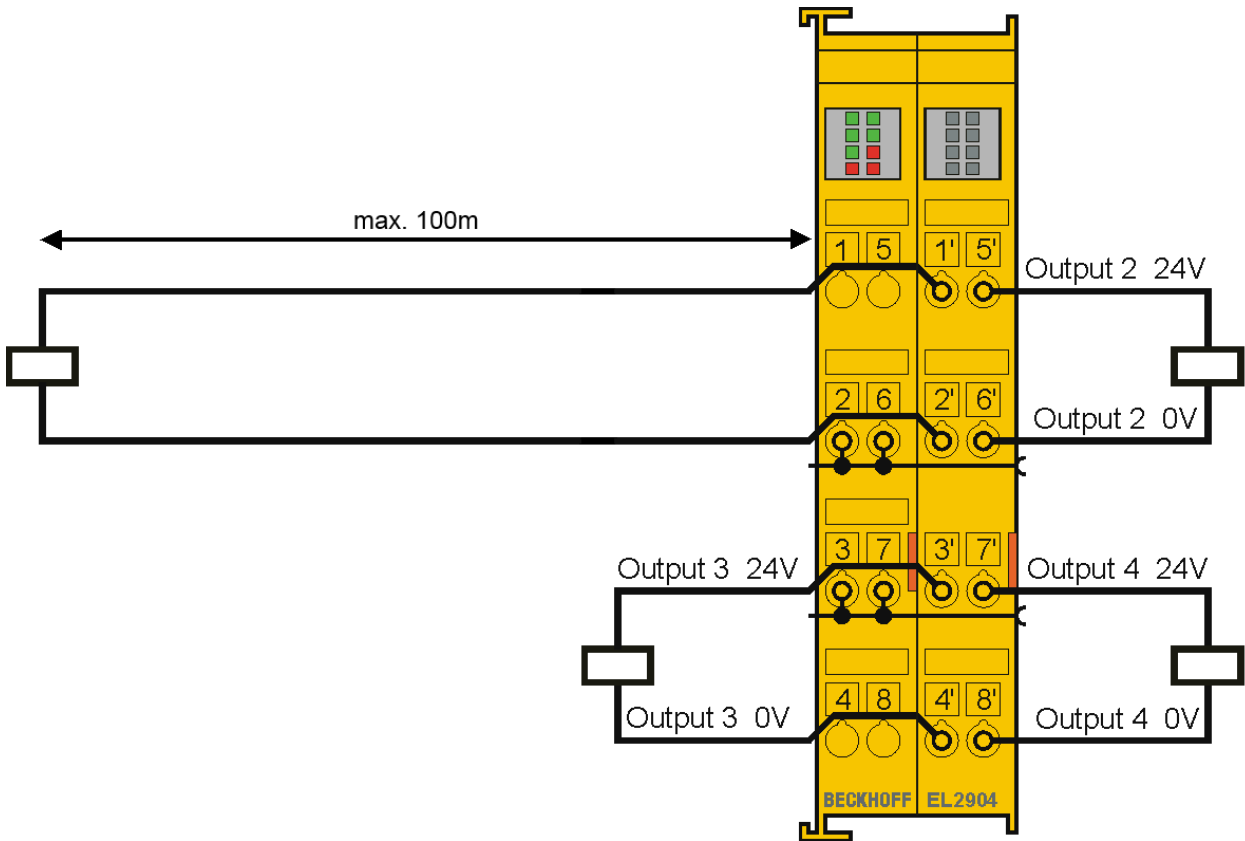

Fig. 10: Permitted cable length

When connecting a single actuator via its own continuous cabling (or via a sheathed cable), the maximum permitted cable length is 100 m.

The use of contact points, connectors or additional actuators in the cabling reduces the maximum propagation.

Cable routing

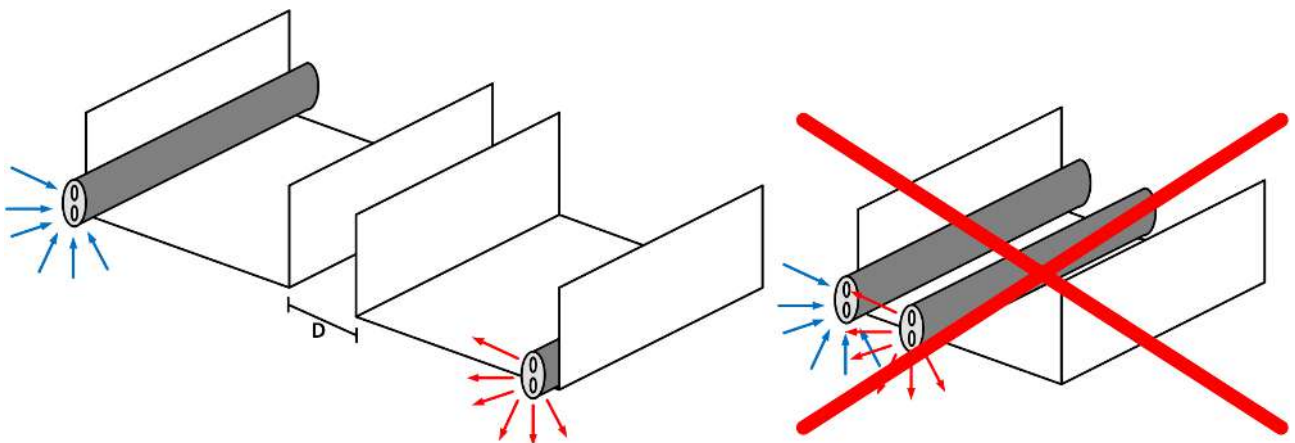

Fig. 11: Cable routing

NOTE

Route the signal cable separately

The signal cable must be routed separately from potential sources of interference, such as motor supply cables, 230 V_{AC} power cables etc.!

Interference caused by cables routed in parallel can influence the signal form of the test pulses and thus cause diagnostic messages (e.g. sensor errors or OpenLoad errors).

D: Distance between the cable ducts should be as large as possible

blue arrows: signal line

red arrows: potential source of interference

The common routing of signals together with other clocked signals in a common cable also reduces the maximum propagation, since crosstalk of the signals can occur over long cable lengths and cause diagnostic messages.

If connection via a bus cable is unavoidable, the test pulses can be switched off (parameters *Testing of outputs active* and *Current measurement active*). However, this then leads to a reduction in the degree of diagnostic cover when calculating the performance level.

Test pulses

The typical length of test pulse (switching from 24 V to 0 V and back to 24 V) is 300 µs to 800 µs. Testing usually takes place 5 to 7 times per second.

Test pulses for the outputs

The following diagram shows a typical test pulse curve for the four outputs of an EL2904. The parameters *Current measurement active* and *Testing of outputs active* are enabled.

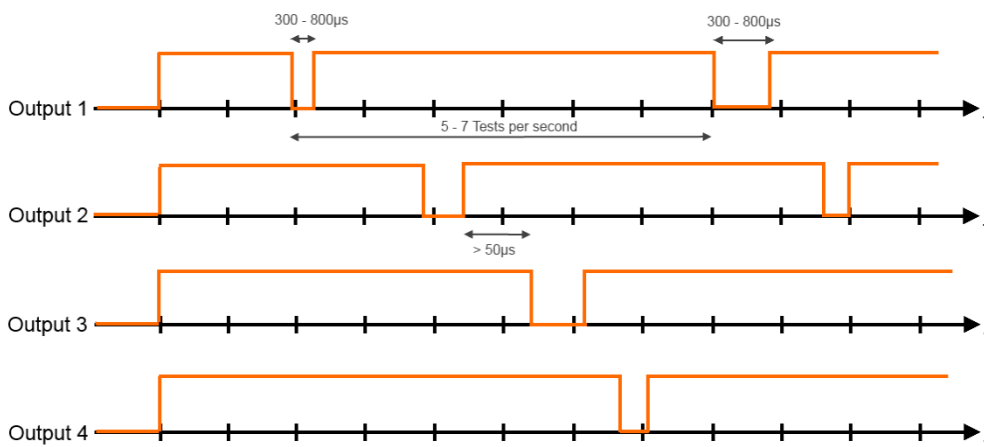

Fig. 12: Typical course of test pulses of the outputs

4.2.4 Mechanical installation

⚠ DANGER

Risk of injury!

Bring the bus system into a safe, de-energized state before starting installation, disassembly or wiring of the devices!

4.2.4.1 Control cabinet / terminal box

The TwinSAFE terminals must be installed in a control cabinet or terminal box with IP54 protection class according to IEC 60529 as a minimum.

4.2.4.2 Installation position and minimum distances

For the prescribed installation position the mounting rail is installed horizontally and the mating surfaces of the EL/KL terminals point toward the front (see illustration below). The terminals are ventilated from below, which enables optimum cooling of the electronics through convection. The direction indication “down” corresponds to the direction of positive acceleration due to gravity.

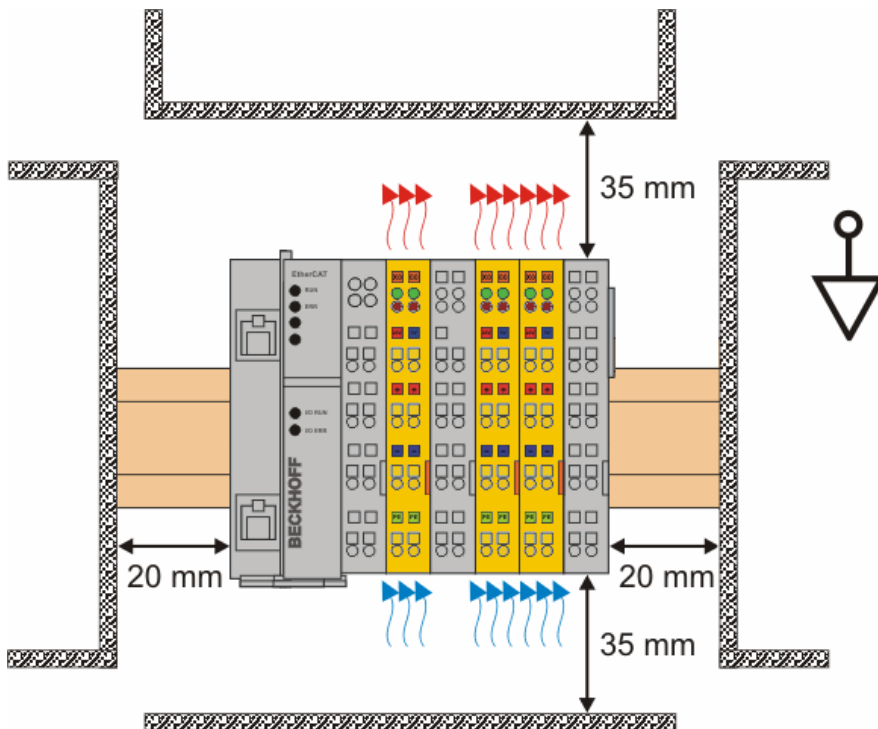

Fig. 13: Installation position and minimum distances

In order to ensure optimum convection cooling, the distances to neighboring devices and to control cabinet walls must not be smaller than those shown in the diagram.

4.2.4.3 Example configuration for temperature measurement

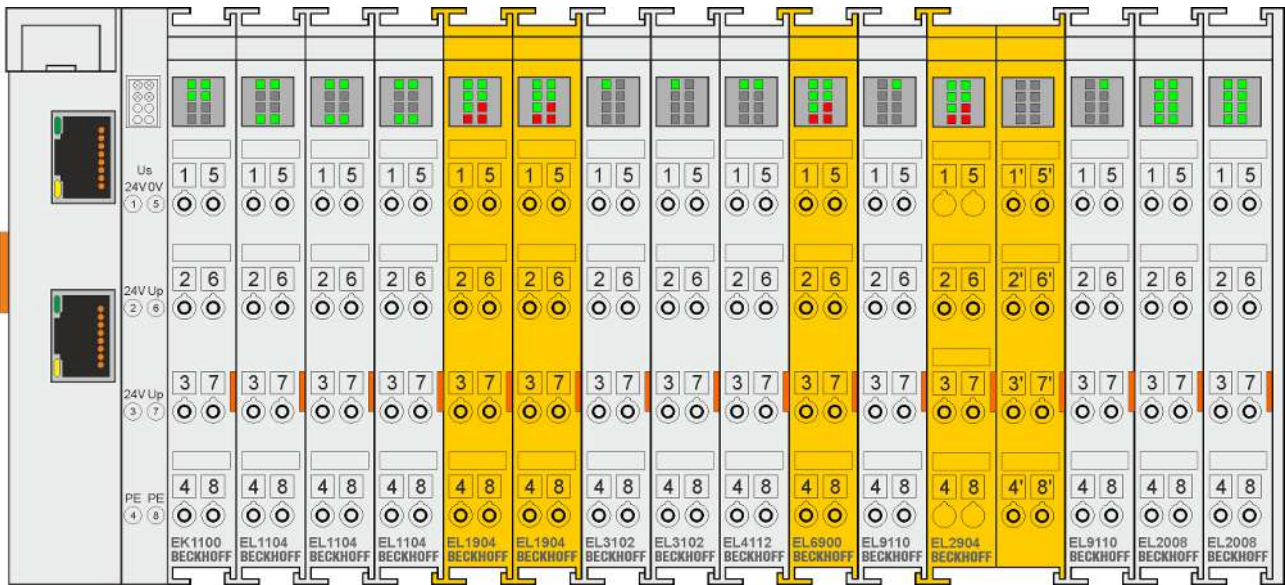

Fig. 14: Example configuration for temperature measurement

The example configuration for the temperature measurement consists of an EK1100 EtherCAT coupler with connected terminals that match the typical distribution of digital and analog signal types at a machine. On the EL6900 a safety project is active, which reads safe inputs and enables all 4 safe outputs during the measurement.

i External heat sources / radiant heat / impaired convection

The maximum permissible ambient temperature of 55°C was checked with the above example configuration. Impaired convection, an unfavorable location near heat sources or an unfavorable configuration of the EtherCAT Terminals may result in overheating of the terminals. The key parameter is always the maximum permitted internally measured temperature of 95°C, above which the TwinSAFE terminals switch to safe state and report an error. The internal temperature can be read from the TwinSAFE components via CoE (see chapter Diagnose).

4.2.4.4 Installation on mounting rails

⚠ WARNING

Risk of electric shock and damage of device!

Bring the bus terminal system into a safe, powered down state before starting installation, disassembly or wiring of the Bus Terminals!

Mounting

The Bus Couplers and Bus Terminals are attached to commercially available 35 mm mounting rails (according to EN 60715) by applying slight pressure:

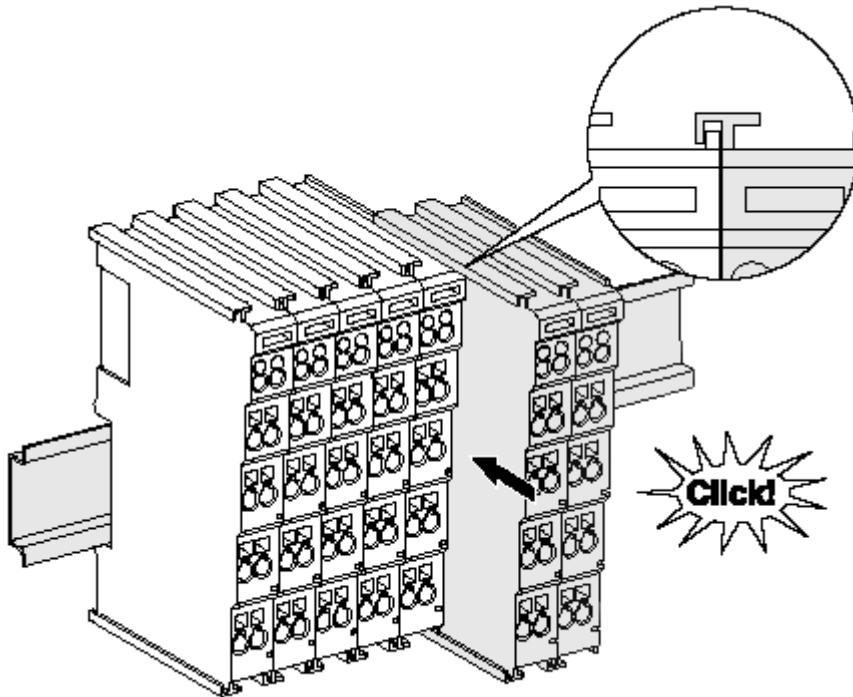

Fig. 15: Installation on the mounting rail

1. First attach the Fieldbus Coupler to the mounting rail.
2. The Bus Terminals are now attached on the right-hand side of the fieldbus Coupler. Join the components with slot and key and push the terminals against the mounting rail, until the lock clicks onto the mounting rail.

If the terminals are clipped onto the mounting rail first and then pushed together without slot and key, the connection will not be operational! When correctly assembled, no significant gap should be visible between the housings.

● Fastening of mounting rails

i The locking mechanism of the terminals and couplers protrudes into the profile of the mounting rail. When installing the components, make sure that the locking mechanism doesn't come into conflict with the fixing bolts of the mounting rail. For fastening mounting rails with a height of 7.5 mm under the terminals and couplers, use flat fastening components such as countersunk head screws or blind rivets.

Removal

Fig. 16: Removal of mounting rails

1. Carefully pull the orange-colored lugs approximately 1 cm out of the disassembled terminal, until they protrude loosely. The lock with the mounting rail is now released for this terminal, and the terminal can be pulled from the mounting rail without excessive force.
2. Grasp the released terminal with thumb and index finger simultaneous at the upper and lower grooved housing surfaces and pull the terminal away from the mounting rail.

4.2.5 TwinSAFE reaction times

The TwinSAFE terminals form a modular safety system that exchanges safety-oriented data via the Safety-over-EtherCAT protocol. This chapter is intended to help you determine the system's reaction time from the change of signal at the sensor to the reaction at the actuator.

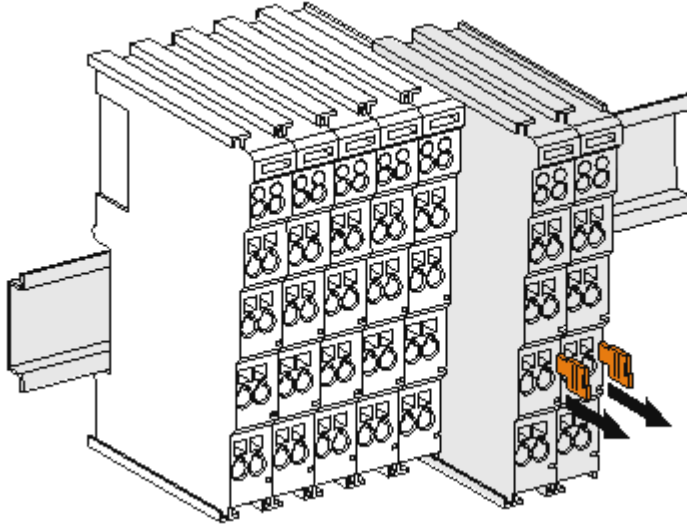
Typical response time

The typical response time is the time required for transferring a piece of information from the sensor to the actuator, when the whole system operates normally, without error.

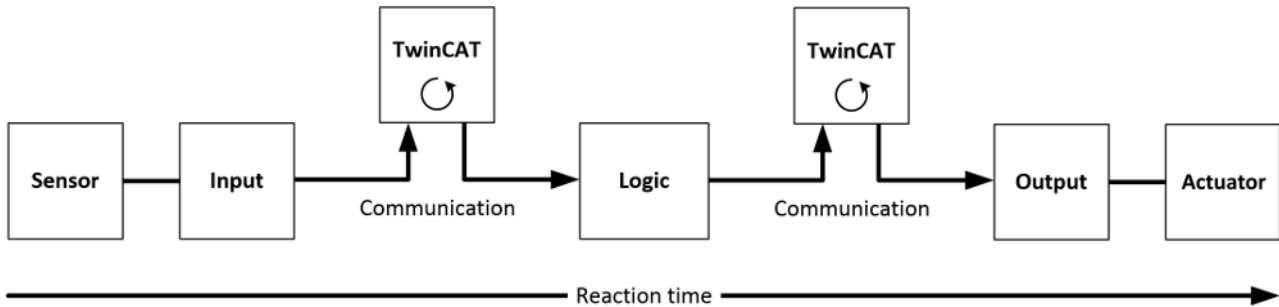

Fig. 17: Typical response time

Definition	Description
RT _{Sensor}	Response time of the sensor, until the signal is made available at the interface. Typically provided by the sensor manufacturer.
RT _{Input}	Response time of the safe input, e.g. EL1904 or EP1908. This time can be found in the technical data. In the case of the EL1904 it is 4 ms.
RT _{Comm}	Response time of the communication. This is typically 3 times the EtherCAT cycle time, since a new Safety-over-EtherCAT telegram has to be generated before new data can be sent. These times depend directly on the higher-level standard controller (cycle time of the PLC/NC).
RT _{Logic}	Response time of the logic terminal. This is the cycle time of the logic terminal and typically ranges from 500 µs to 10 ms for the EL6900, depending on the size of the safety project. The actual cycle time can be read from the terminal.
RT _{Output}	Response time of the output terminal. This is typically between 2 and 3 ms.
RT _{Actuator}	Response time of the actuator. This information is typically provided by the actuator manufacturer
WD _{Comm}	Watchdog time of the communication

The typical response time is based on the following formula:

$$ReactionTime_{typ} = RT_{Sensor} + RT_{Input} + 3 * RT_{Comm} + RT_{Logic} + 3 * RT_{Comm} + RT_{Output} + RT_{Actuator}$$

with

$$ReactionTime_{typ} = 5ms + 4ms + 3 * 1ms + 10ms + 3 * 1ms + 3ms + 20ms = 48ms$$

Worst case response time

The worst-case response time is the maximum time required for switching off the actuator in the event of an error.

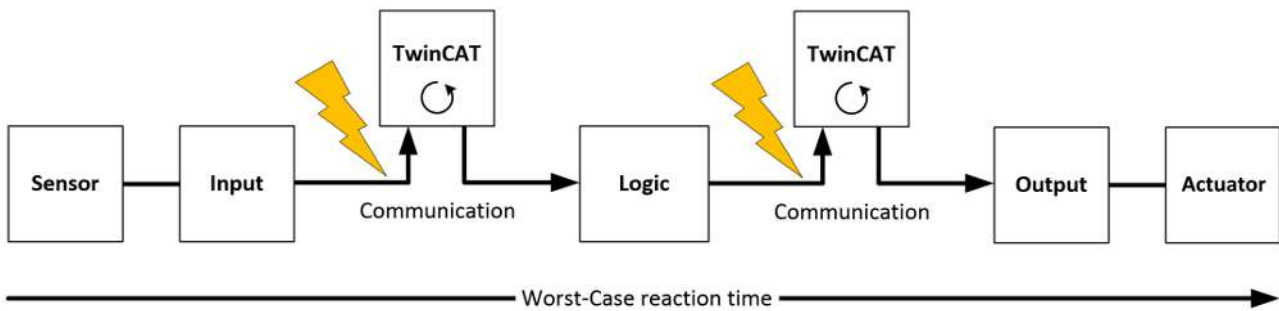

Fig. 18: Worst case response time

It is assumed that a signal change takes place at the sensor, and that this is passed to the input. A communication error occurs just at the moment when the signal is to be passed to the communication interface. This is detected by the logic once the watchdog time of the communication link has elapsed. This information should then be passed on to the output, resulting in a further communication error. This fault is detected at the output once the watchdog time has elapsed, resulting in shutdown.

This results in the following formula for the worst-case response time:

$$ReactionTime_{max} = WD_{Comm} + WD_{Comm} + RT_{Actuator}$$

with

$$ReactionTime_{max} = 2 * 15ms + 20ms = 50ms$$

4.2.6 Tested EL2904 devices

The following list contains devices that were tested together with the EL2904 TwinSAFE terminal. The results only apply for the current device hardware version at the time of testing. The tests were carried out in a laboratory environment. Modifications of these products cannot be considered here. If you are unsure please test the hardware together with the TwinSAFE terminal.

Manufacturer	Type	Comment
Beckhoff	AX5801	TwinSAFE Drive option card: safe restart lock
Beckhoff	AX2000 AS option	safe restart lock
Siemens	SIRIUS series S00 3RT1016-1BB42	Contactator
Telemecanique	LP1K09	Contactator

The tests were carried out as function tests only. The information provided in the respective manufacturer documentation remains valid.

i Recommended protective circuits

We recommend R/C or diode-based protective circuits for these devices. Varistor-based protective circuits should not be used.

4.3 Operation in potentially explosive atmospheres (ATEX)

4.3.1 Special conditions

⚠ WARNING

Observe the special conditions for the intended use of Beckhoff fieldbus components in potentially explosive areas (directive 94/9/EU)!

The certified components are to be installed in a suitable housing that guarantees a protection class of at least IP54 in accordance with EN 60529! The environmental conditions during use are thereby to be taken into account!

If the temperatures during rated operation are higher than 70 °C at the feed-in points of cables, lines or pipes, or higher than 80°C at the wire branching points, then cables must be selected whose temperature data correspond to the actual measured temperature values!

Observe the permissible ambient temperature range of 0 to 55 °C when using Beckhoff fieldbus components in potentially explosive atmospheres!

Measures must be taken to protect against the rated operating voltage being exceeded by more than 40% due to short-term interference voltages!

The individual terminals may only be unplugged or removed from the Bus Terminal system if the supply voltage has been switched off or if a non-explosive atmosphere is ensured!

The connections of the certified components may only be connected or disconnected if the supply voltage has been switched off or if a non-explosive atmosphere is ensured!

The fuses of the EL92xx power feed terminals may only be exchanged if the supply voltage has been switched off or if a non-explosive atmosphere is ensured!

Address selectors and ID switches may only be adjusted if the supply voltage has been switched off or if a non-explosive atmosphere is ensured!

The fundamental health and safety requirements are fulfilled by compliance with the following standards:

- EN 60079-0: 2006
- EN 60079-15: 2005

4.3.2 Identification

Beckhoff fieldbus components that are certified for use in potentially explosive atmospheres bear one of the following markings:



II 3 G Ex nA IIC T4 Gc KEMA 10ATEX0075 X
Ta: 0 ... 55 °C

or



II 3 G Ex nA nC IIC T4 Gc KEMA 10ATEX0075 X
Ta: 0 ... 55 °C

4.3.3 Date code and serial number

The TwinSAFE terminals bear a date code, which is composed as follows:

Date code: CW YY SW HW

Legend:

CW: Calendar week of manufacture

YY: Year of manufacture

SW: Software version

HW: Hardware version

Sample: Date code 29 10 02 01

Calendar week: 29

Year: 2010

Software version: 02

Hardware version: 01

In addition the TwinSAFE terminals bear a unique serial number.

4.3.4 Further ATEX documentation

Please also refer to the further documentation



Notes regarding application of the Bus Terminal system in areas potentially explosive atmosphere are available in the [Download](#) section of the Beckhoff website at <http://www.beckhoff.de>.

4.4 Configuration of the terminal in TwinCAT

CAUTION

Do not change CoE objects!

Do not change any of the CoE objects in the TwinSAFE terminals. Any modifications (e.g. via TwinCAT) of the CoE objects will permanently set the terminals to the Fail-Stop state or lead to unexpected behavior of the terminals!

4.4.1 Inserting a Bus Coupler

See TwinCAT automation software documentation.

4.4.2 Inserting a Bus Terminal

See TwinCAT automation software documentation.

4.4.3 Inserting an EL2904

An EL2904 is inserted in the same way as any other Beckhoff Bus Terminal. In the list open *Safety Terminals (ELx9xx)* and select the EL2904.

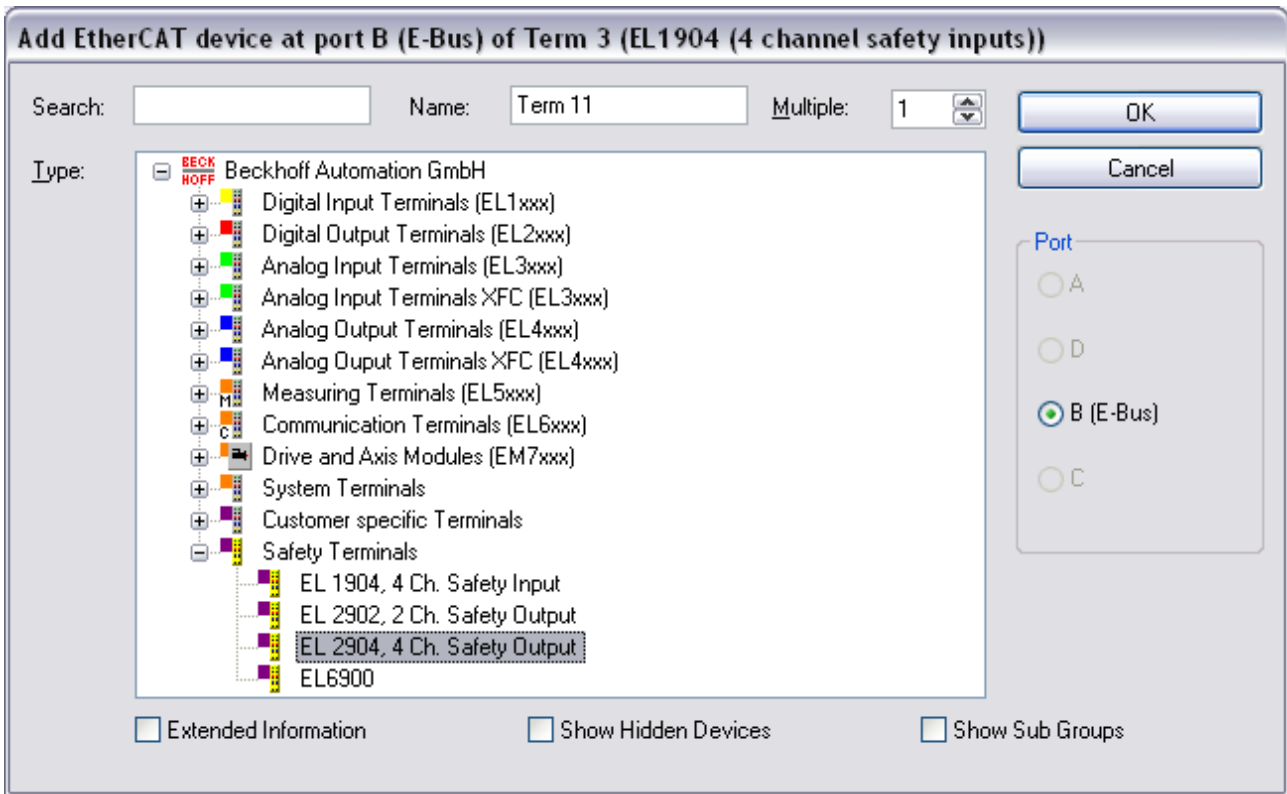

Fig. 19: Inserting an EL2904

4.4.4 Address settings on TwinSAFE terminals with 1023 possible addresses

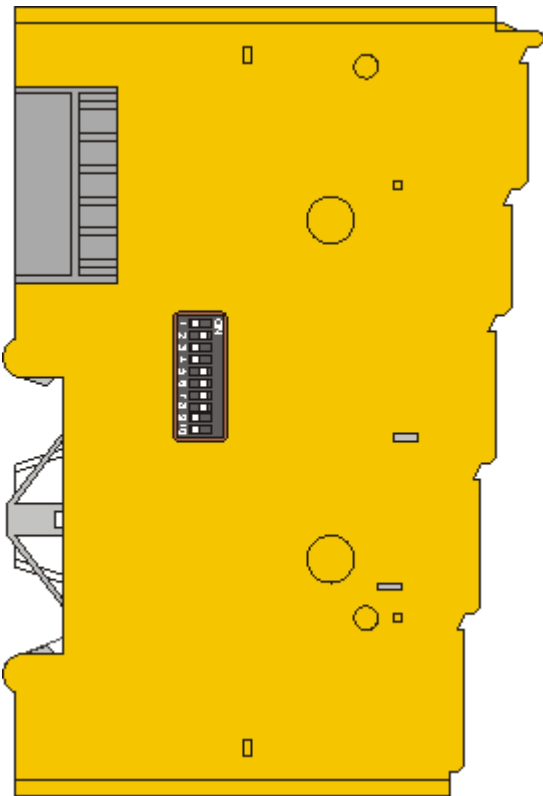

Fig. 20: Address settings on TwinSAFE terminals with 1023 possible addresses

The TwinSAFE address of the terminal is set via the 10-way DIP switch on the left-hand side of the TwinSAFE terminal. TwinSAFE addresses between 1 and 1023 are available.

DIP switch										Address
1	2	3	4	5	6	7	8	9	10	
ON	OFF	OFF	OFF	OFF	OFF	OFF	OFF	OFF	OFF	1
OFF	ON	OFF	OFF	OFF	OFF	OFF	OFF	OFF	OFF	2
ON	ON	OFF	OFF	OFF	OFF	OFF	OFF	OFF	OFF	3
OFF	OFF	ON	OFF	OFF	OFF	OFF	OFF	OFF	OFF	4
ON	OFF	ON	OFF	OFF	OFF	OFF	OFF	OFF	OFF	5
OFF	ON	ON	OFF	OFF	OFF	OFF	OFF	OFF	OFF	6
ON	ON	ON	OFF	OFF	OFF	OFF	OFF	OFF	OFF	7
...
ON	ON	ON	ON	ON	ON	ON	ON	ON	ON	1023

⚠ WARNING

TwinSAFE address

Each TwinSAFE address may only be used once within a network / a configuration!
The address 0 is not a valid TwinSAFE address!

4.4.5 Entering a TwinSAFE address and parameters in the System Manager

The FSoE address set at the DIP switch must also be entered under the *FSoE* tab (*FSoE_Address* entry).

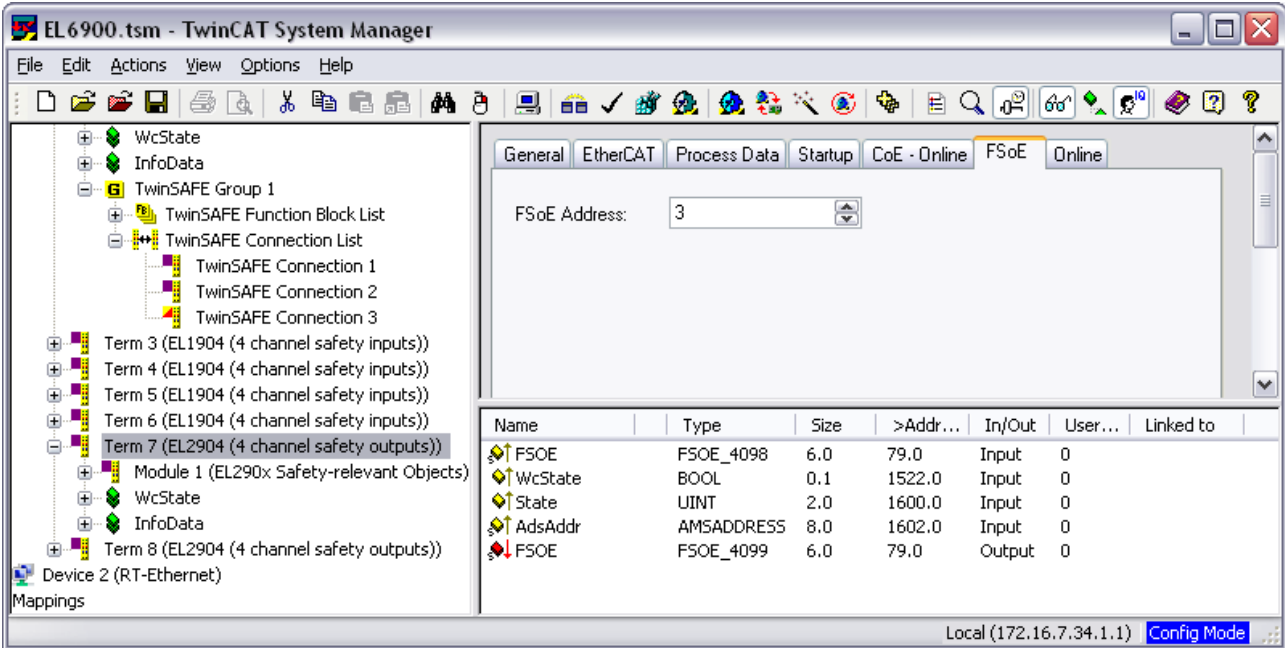

Fig. 21: Entering the FSoE address

The EL2904 parameters are set under the respective TwinSAFE connection in the *Connection* and *Parameter* tabs.

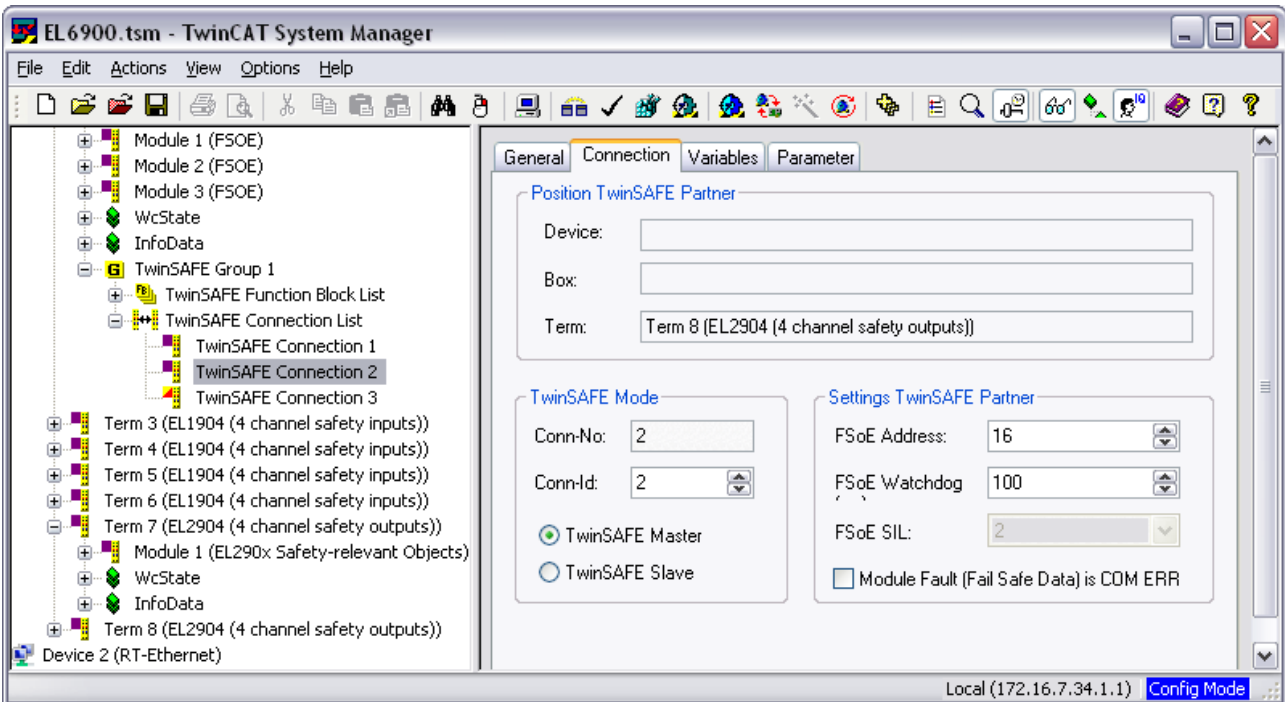

Fig. 22: Setting the connection of the TwinSAFE connection

Entry	Name	Value
#x8000:1	Standard outputs active	false
#x8000:2	Current measurement active	true
#x8000:3	Testing of outputs active	true
#x8000:4	Error acknowledge active	false
#x10E0:1	Store Code	0x0
#x10E0:2	Project CRC	0x0

Fig. 23: Setting the parameters of the TwinSAFE connection

Parameter overview

PrmName	Meaning	Values
Standard outputs active	In addition the output can be switched off from the standard PLC. The safe output is linked with the standard logic signal AND.	true / false
Current measurement active	Current measurement for the outputs is activated	true / false
Testing of outputs active	Test pulses for the outputs are activated	true / false
Error acknowledge active	True: Terminal errors lead to a reset of the TwinSAFE connection (error code 14 (0x0E)). This error code is shown in the diagnostic data for the connection until the user acknowledges it via ErrAck in the TwinSAFE group. False (Default): Terminal errors can only be reset by switching the power supply off and back on again.	true / false
Store Code	This parameter is required for the TwinSAFE Restore Mode	0x0000
Project CRC	This parameter is required for the TwinSAFE Restore Mode	0x0000

● Test pulses

i If the parameters Current Measurement active or Testing of outputs active are set to TRUE, the terminal generates test pulses at the outputs.

To avoid generating test pulses at the channel outputs, Testing of outputs active and Current measurement active must be set to FALSE.

Please note that deactivating of Current measurement active and/or Testing of outputs active may reduce the achievable performance level.

A calculation example for the performance level can be found in the TwinSAFE application manual.

There are no known application for which it would make sense to set Testing of outputs active to FALSE, while Current measurement active is set to TRUE.

4.5 Diagnostics

4.5.1 Diagnostic LEDs

The LEDs Diag 1 to Diag 4 display diagnostic information for the EL2904.

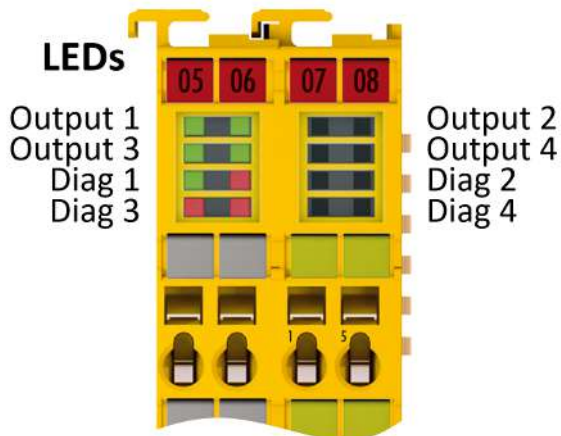

Fig. 24: Diagnostic LEDs

Diag 1 (green)

The *Diag 1* LED indicates the state of the TwinSAFE interface (in preparation).

Flashing Code	Meaning
LED illuminated continuously	Diagnostic flashing code in preparation

Diag 2 (red)

The *Diag 2* LED indicates the state of the digital outputs.

Flashing Code	Meaning (see chapter Possible causes of diagnostic messages [▶ 43])
rapid flickering, alternating with 1 flash pulse	Error at output 1
rapid flickering, alternating with 2 flash pulses	Error at output 2
rapid flickering, alternating with 3 flash pulses	Error at output 3
rapid flickering, alternating with 4 flash pulses	Error at output 4
rapid flickering, alternating with 5 flash pulses	Field voltage too low
rapid flickering, alternating with 6 flash pulses	Field voltage too high
rapid flickering, alternating with 7 flash pulses	Internal terminal temperature too low
rapid flickering, alternating with 8 flash pulses	Internal terminal temperature too high
rapid flickering, alternating with 9 flash pulses	Temperature difference error
rapid flickering, alternating with 10 flash pulses	Error in output circuit

These errors can only be reset by switching the power supply for the TwinSAFE terminal off and back on again.

Diag 3 (red) and Diag 4 (red)

If the Diag 3 LED is lit, the Diag 4 LED indicates internal terminal errors.

These errors lead to shutdown of the terminal. The terminal must be checked by Beckhoff Automation GmbH & Co. KG.

Flashing Code

In the case of such an error, the *Diag 4* LED on the EL2904 displays flashing codes that describe the error in more detail.

A flashing code consists of four sequences, which are interrupted in each case by a short break. After the four sequences there is a long break, following which the flashing code is displayed again.

Count the individual sequences of the flashing code.



Note the flashing codes and return the terminal

Note the flashing code displayed and include this information with the terminal when you return it.

4.5.2 Diagnostic objects

⚠ CAUTION

Do not change CoE objects!

Do not make any modifications to the CoE objects in the TwinSAFE components! Any modifications (e.g. using TwinCAT) of the CoE objects will permanently set the TwinSAFE components to the Fail-Stop state.

Index FA80_{hex}: Internal temperature values

The CoE objects FA80_{hex} indicate the current internal temperature values of the EL2904.

Index	Name	Meaning	Flags	Default
FA80:01	Temperature 1	Temperature measurement 1 (left board)	RO	0 _{bin}
FA80:02	Temperature 2	Temperature measurement 2 (left board)	RO	0 _{bin}
FA80:03	Temperature Outputs	Temperature measurement (right board)	RO	0 _{bin}

Index 800E_{hex}: Diagnostic objects

The CoE objects 800E_{hex} display further diagnostic information.

Index	Name	Meaning	Flags	Default	
800E:0	Diag	The following sub-indices contain detailed diagnostic information.	RO		
800E:0C	Error at the output	Bit	External supply or cross-circuit*	RO	
		0	1 _{bin} : Output 1		0 _{bin}
		1	1 _{bin} : Output 2		0 _{bin}
		2	1 _{bin} : Output 3		0 _{bin}
		3	1 _{bin} : Output 4		0 _{bin}
		Bit	Open load or current below minimum value of 20 mA or current above maximum value of 500 mA**		0 _{bin}
		4	1 _{bin} : Output 1		
		5	1 _{bin} : Output 2		0 _{bin}
800E:0D	Supply error	Bit	Field voltage (power contacts) outside the specification	RO	
		0	1 _{bin} : Field voltage too high		0 _{bin}
		1	1 _{bin} : Field voltage too low		0 _{bin}
800E:0E	Temperature error	Bit	Terminal temperature outside the specification.	RO	
		0	1 _{bin} : Overtemperature μ C1		0 _{bin}
		1	1 _{bin} : Overtemperature μ C2		0 _{bin}
		2	1 _{bin} : Overtemperature of the output board		0 _{bin}
		3	1 _{bin} : Temperature too low μ C1		0 _{bin}
		4	1 _{bin} : Temperature too low μ C2		0 _{bin}
		5	1 _{bin} : Temperature of the output board too low		0 _{bin}
		6	1 _{bin} : Temperature difference on the processor board too large		0 _{bin}
7	1 _{bin} : Temperature difference between the boards is too large	0 _{bin}			

*) These diagnostic messages are displayed only if Current Measurement active = false.

***) These diagnostic messages are displayed only if Current Measurement active = true. If no channel-specific diagnostic is possible, all bits (4...7) are set. This is independent of the parameter settings.

i Differing diagnostic messages possible

Due to the variable order or execution of the test series, diagnostic messages differing from those given in the table above are possible.

4.5.3 Possible causes of diagnostic messages

Diagnosics	Possible cause	Remedial actions
Diag 2 LED Flash code 1 to 4 or 10	If parameters "Testing of outputs active" and/or "Current measurement active" are enabled: Faulty test pulses. Cause: external supply or cross-circuit.	Eliminate cross-circuit or external supply.
	Faulty test pulses. Cause: parallel routed cables with high capacitive coupling and dynamized signals, possibly also in common cables	Isolate lines and lay in separate non-metallic sheathed cable. Create a distance between the non-metallic sheathed cables.
	Cause: Current is below the limit of 20 mA or above the limit of 500 mA.	Select actuator accordingly. Current > 20mA and < 500mA
	Regardless of whether the parameters "Testing of outputs active" and/or "Current measurement active" are enabled: The output voltage lies below the permissible voltage range (24V -15%/+20%). A possible cause is a short-circuit at the output or e.g. a voltage drop at the instant of switching.	Eliminate short-circuit. Design power supply accordingly. Check supply lines for voltage drop.
	EMC faults	Take suitable EMC measures
	Internal defect	Replace terminal
Diag 2 LED Flash code 5	Voltage at the power contacts not switched on.	Switch on voltage at the power contacts and reset the error display through PowerOn Reset of the terminal
	Voltage at the power contacts was switched on after the terminal supply	Switch on voltage at the power contacts before or at the same time as the terminal supply and reset the error display through PowerOn Reset of the terminal
	Voltage on the power contacts too low.	Increase the voltage at the power contacts and reset the error display through PowerOn Reset of the terminal
	EMC faults	Take suitable EMC measures
	Internal defect	Replace terminal
Diag 2 LED Flash code 6	Field voltage too high. Voltage on the power contacts too high.	Reduce the voltage at the power contacts and reset the error display through PowerOn Reset of the terminal
	Voltage briefly too high due to external influences, such as switching contactors off.	Use an R/C or diode-based protective circuit on the actuators
	EMC faults	Take suitable EMC measures
	Internal defect	Replace terminal
Diag 2 LED Flash code 7	Terminal temperature too low	Comply with the specified temperature range
	EMC faults	Take suitable EMC measures
	Internal defect	Replace terminal
Diag 2 LED Flash code 8	Terminal temperature too high	Comply with the specified temperature range
	EMC faults	Take suitable EMC measures
	Internal defect	Replace terminal
Diag 2 LED Flash code 9	Terminal temperature difference too large: one of the 3 internal measuring points is faulty	Replace terminal
	Terminal temperature difference too large: An internal measuring point shows an elevated temperature due to inadequate convection.	Check the installation position of the terminal and modify it according to the specifications in section <i>Mechanical installation</i> , if required
	EMC faults	Take suitable EMC measures
	Internal defect	Replace terminal

4.6 Maintenance

Maintenance

The TwinSAFE components are maintenance-free!

Environmental conditions

⚠ WARNING

Observe the specified environmental conditions!

Please ensure that the TwinSAFE components are only stored and operated under the specified conditions (see technical data).

If the TwinSAFE component is operated outside the permitted temperature range it will switch to *Global Shutdown* state.

Cleaning

Protect the TwinSAFE component from unacceptable soiling during operation and storage!

If the TwinSAFE component was subjected to unacceptable soiling it may no longer be operated!

⚠ WARNING

Have soiled terminals checked!

Cleaning of the TwinSAFE component by the user is not permitted!
Please send soiled terminals to the manufacturer for inspection and cleaning!

4.7 Service life

The TwinSAFE terminals are designed for a service life of 20 years.

Due to the high diagnostic coverage within the lifecycle no special proof tests are required.

The TwinSAFE terminals bear a date code, which is composed as follows:

Date code: CW YY SW HW

Legend:

CW: Calendar week of manufacture

YY: Year of manufacture

SW: Software version

HW: Hardware version

Sample: Date Code 17 11 05 00

Calendar week: 17

Year: 2011

Software version: 05

Hardware version: 00

In addition the TwinSAFE terminals bear a unique serial number.

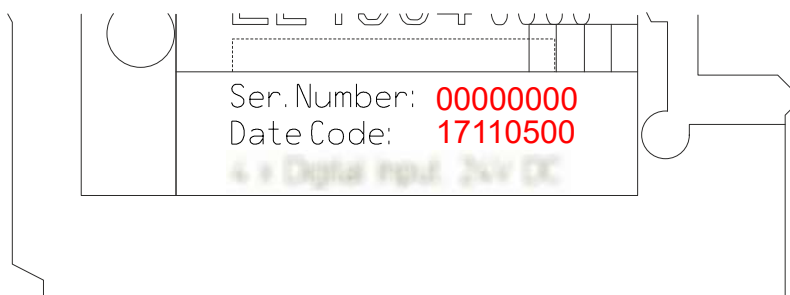

Fig. 25: Unique serial number of a TwinSAFE terminal

4.8 Decommissioning

WARNING

Risk of electric shock!

Bring the bus system into a safe, de-energized state before starting disassembly of the devices!

Disposal

In order to dispose of the device, it must be removed.

In accordance with the WEEE Directive 2012/19/EU, Beckhoff takes back old devices and accessories in Germany for proper disposal. Transport costs will be borne by the sender.

Return the old devices with the note "for disposal" to:
Beckhoff Automation GmbH & Co. KG
Service Department
Stahlstrasse 31
D-33415 Verl

Observe the applicable national laws and guidelines for disposal!

- Housing components (polycarbonate, polyamide (PA6.6)) are suitable for plastic recycling.
- Metal parts can be sent for metal recycling.
- Electronic parts such as circuit boards must be disposed of in accordance with national electronics scrap regulations.

5 Appendix

5.1 Support and Service

Beckhoff and their partners around the world offer comprehensive support and service, making available fast and competent assistance with all questions related to Beckhoff products and system solutions.

Beckhoff's branch offices and representatives

Please contact your Beckhoff branch office or representative for local support and service on Beckhoff products!

The addresses of Beckhoff's branch offices and representatives round the world can be found on her internet pages: <https://www.beckhoff.com>

You will also find further documentation for Beckhoff components there.

Beckhoff Support

Support offers you comprehensive technical assistance, helping you not only with the application of individual Beckhoff products, but also with other, wide-ranging services:

- support
- design, programming and commissioning of complex automation systems
- and extensive training program for Beckhoff system components

Hotline: +49 5246 963 157
Fax: +49 5246 963 9157
e-mail: support@beckhoff.com

Beckhoff Service

The Beckhoff Service Center supports you in all matters of after-sales service:

- on-site service
- repair service
- spare parts service
- hotline service

Hotline: +49 5246 963 460
Fax: +49 5246 963 479
e-mail: service@beckhoff.com

Beckhoff Headquarters

Beckhoff Automation GmbH & Co. KG

Huelshorstweg 20
33415 Verl
Germany

Phone: +49 5246 963 0
Fax: +49 5246 963 198
e-mail: info@beckhoff.com
web: <https://www.beckhoff.com>

5.2 Certificates

BECKHOFF New Automation Technology

Reliability of EL2904

Reliability of EL2904

Test and Certification body

TÜV SÜD Rail GmbH
 Rail Automation - IQSE
 Barthstraße 16
 D-80339 Munich



Manufacturer

Beckhoff Automation GmbH & Co. KG
 Huelshorstweg 20
 D-33415 Verl

Safety parameters EL2904

Key figures	EL2904
Lifetime [a]	20
Proof test Intervall [a]	not required ¹⁾
PFH _b	1.25E-09
%SIL3	1.25%
PFD	8.45E-05
%SIL3	8.45%
MTTF _d	High
B10d (cycles)	-
DC	High
Performance level	PL e
Category	4
HFT	1
Element classification*	Type B

*) Classification according to IEC 61508-2:2010 (see chapters 7.4.4.1.2 and 7.4.4.1.3)

The EL2904 EtherCAT Terminal can be used for safety-related applications within the meaning of IEC 61508:2010 up to SIL3 and EN ISO 13849-1 up to PL e (Cat4).

¹⁾Special proof tests for the product are not required during the lifetime of the EL2904 EtherCAT terminal as a result of the high diagnostic coverage of the system.

Munich, 2016-03-07

Günter Greil

Digital unterschrieben von
 Günter Greil
 DN: c=DE, o=TUEV SÜD
 Rail GmbH, ou=Rail &
 Automation, cn=Günter
 Greil,
 email=guenter.greil@tuev
 -sued.de
 Datum: 2016.03.07
 17:51:11 +0100

TwinSAFE Reliability

7



Product Service

CERTIFICATE

No. Z10 062386 0060 Rev. 00

Holder of Certificate: Beckhoff Automation GmbH & Co. KG

Hülshorstweg 20
33415 Verl
GERMANY

Factory(ies): 062386

Certification Mark:



Product: Safety components

Model(s): KL 2904, EL 2904

Parameters:

Supply voltage:	24VDC (-15%/+20%)
Power dissipation:	2W
Protection class:	IP 20

Tested according to:

- 2006/42/EC
- EN 61508-1:2010 (up to SIL 3)
- EN 61508-2:2010 (up to SIL 3)
- EN 61508-3:2010 (up to SIL 3)
- EN 62061:2005/A2:2015 (SIL CL3)
- EN ISO 13849-1:2015 (Cat. 4, PL e)
- EN 81-20:2014
- EN 81-22:2014
- EN 81-50:2014
- EN 13243:2015

The product was tested on a voluntary basis and complies with the essential requirements. The certification mark shown above can be affixed on the product. It is not permitted to alter the certification mark in any way. In addition the certification holder must not transfer the certificate to third parties. See also notes overleaf.

Test report no.: BV82168T
Valid until: 2024-06-06

Date, 2019-06-07

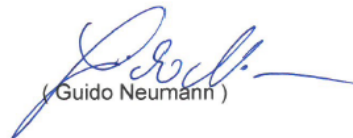
(Guido Neumann)

List of illustrations

Fig. 1	Slot and key system and screwless (spring-loaded) connection system.....	10
Fig. 2	Bus Coupler (EtherCAT).....	11
Fig. 3	TwinSAFE Terminals (EtherCAT).....	12
Fig. 4	EL2904 – TwinSAFE terminal with 4 digital fail-safe outputs	15
Fig. 5	Dimensions of the EL2904.....	20
Fig. 6	Block diagram of the EL2904.....	21
Fig. 7	PE power contact.....	23
Fig. 8	Connection of a cable to a terminal point	24
Fig. 9	EL2904 pin assignment	25
Fig. 10	Permitted cable length	26
Fig. 11	Cable routing	26
Fig. 12	Typical course of test pulses of the outputs.....	27
Fig. 13	Installation position and minimum distances	28
Fig. 14	Example configuration for temperature measurement.....	29
Fig. 15	Installation on the mounting rail	30
Fig. 16	Removal of mounting rails	31
Fig. 17	Typical response time.....	32
Fig. 18	Worst case response time	33
Fig. 19	Inserting an EL2904.....	36
Fig. 20	Address settings on TwinSAFE terminals with 1023 possible addresses	37
Fig. 21	Entering the FSoE address.....	38
Fig. 22	Setting the connection of the TwinSAFE connection.....	38
Fig. 23	Setting the parameters of the TwinSAFE connection	39
Fig. 24	Diagnostic LEDs	40
Fig. 25	Unique serial number of a TwinSAFE terminal.....	44

More Information:
www.beckhoff.com/el2904

Beckhoff Automation GmbH & Co. KG
Hülshorstweg 20
33415 Verl
Germany
Phone: +49 5246 9630
info@beckhoff.com
www.beckhoff.com

