

# SoftLogix 5800 System

Catalog Numbers 1789-L10, 1789-L30, 1789-L60



## Important User Information

Read this document and the documents listed in the additional resources section about installation, configuration, and operation of this equipment before you install, configure, operate, or maintain this product. Users are required to familiarize themselves with installation and wiring instructions in addition to requirements of all applicable codes, laws, and standards.

Activities including installation, adjustments, putting into service, use, assembly, disassembly, and maintenance are required to be carried out by suitably trained personnel in accordance with applicable code of practice.

If this equipment is used in a manner not specified by the manufacturer, the protection provided by the equipment may be impaired.

In no event will Rockwell Automation, Inc. be responsible or liable for indirect or consequential damages resulting from the use or application of this equipment.

The examples and diagrams in this manual are included solely for illustrative purposes. Because of the many variables and requirements associated with any particular installation, Rockwell Automation, Inc. cannot assume responsibility or liability for actual use based on the examples and diagrams.

No patent liability is assumed by Rockwell Automation, Inc. with respect to use of information, circuits, equipment, or software described in this manual.

Reproduction of the contents of this manual, in whole or in part, without written permission of Rockwell Automation, Inc., is prohibited.

Throughout this manual, when necessary, we use notes to make you aware of safety considerations.



**WARNING:** Identifies information about practices or circumstances that can cause an explosion in a hazardous environment, which may lead to personal injury or death, property damage, or economic loss.



**ATTENTION:** Identifies information about practices or circumstances that can lead to personal injury or death, property damage, or economic loss. Attentions help you identify a hazard, avoid a hazard, and recognize the consequence.

---

### IMPORTANT

Identifies information that is critical for successful application and understanding of the product.

---

Labels may also be on or inside the equipment to provide specific precautions.



**SHOCK HAZARD:** Labels may be on or inside the equipment, for example, a drive or motor, to alert people that dangerous voltage may be present.



**BURN HAZARD:** Labels may be on or inside the equipment, for example, a drive or motor, to alert people that surfaces may reach dangerous temperatures.



**ARC FLASH HAZARD:** Labels may be on or inside the equipment, for example, a motor control center, to alert people to potential Arc Flash. Arc Flash will cause severe injury or death. Wear proper Personal Protective Equipment (PPE). Follow ALL Regulatory requirements for safe work practices and for Personal Protective Equipment (PPE).

---

**Introduction**

This document contains new and updated information. To find new and updated information, look for change bars, as shown next to this paragraph.

**Updated Information**

The document contains these changes. This table represents major topics. Make sure to look for the change bars throughout this document.

Topic	Page
Content has been updated to reflect support of the Studio 5000 Logix Designer™ application, version 23.	Throughout

**Notes:**

<b>Preface</b>	Studio 5000 Environment . . . . .	11
	Additional Resources . . . . .	12
	<b>Chapter 1</b>	
<b>SoftLogix 5800 System</b>	About the SoftLogix 5800 Controller . . . . .	13
	Before You Begin . . . . .	14
	Install the SoftLogix 5800 Controller . . . . .	15
	FactoryTalk Activation Manager . . . . .	16
	Node-locked Activation . . . . .	16
	Concurrent Activation . . . . .	16
	Run the FactoryTalk Activation Manager . . . . .	16
	Activation Tools and Rehosting . . . . .	17
	Troubleshoot FactoryTalk Activations . . . . .	18
	Configure the RSLinx Virtual-backplane Driver . . . . .	19
	<b>Chapter 2</b>	
<b>What is the SoftLogix System?</b>	SoftLogix System Components . . . . .	22
	SoftLogix System Description . . . . .	23
	Set Up the Chassis Monitor . . . . .	24
	Determine a Memory Size . . . . .	25
	Specify a Periodic Save Interval . . . . .	26
	Configure the SoftLogix Controller . . . . .	27
	Step 1: Create and Configure the Controller in the SoftLogix Chassis Monitor . . . . .	27
	Change the RSLinx Software Slot . . . . .	29
	Step 2: Create the New Controller Project in the Logix Designer Application . . . . .	31
	Step 3: Configure the Controller in the Logix Designer Application Project . . . . .	32
	Developing Programs . . . . .	34
	Configuring Tasks . . . . .	34
	Determining Programs . . . . .	36
	Supporting Routines . . . . .	37
	Instruction Execution . . . . .	37
	How the SoftLogix System Uses Connections . . . . .	38
	Connections for Produced and Consumed Tags . . . . .	38
	Connections for Messages . . . . .	39
	Connections for I/O Modules . . . . .	40
	Total Connection Requirements . . . . .	40
	Restart the Controller . . . . .	41
	Online with the Controller . . . . .	41
	Upload to the Controller . . . . .	41
	Select a System Overhead Percentage . . . . .	42

<b>Communicate with Devices on an Ethernet Network</b>	<b>Chapter 3</b>	
	Configure Your System for an Ethernet Network . . . . .	43
	Step 1: Disable UDP Messages in RSLinx Classic Software . . . . .	44
	Disabling the UDP option. . . . .	45
	Enabling the UDP option . . . . .	46
	Step 2: Create the Communication Card in the SoftLogix Chassis Monitor . . . . .	48
	Step 3: Configure the Communication Card as Part of the Project . . . . .	50
	Step 4: Configure the SoftLogix EtherNet/IP Module to Communicate on an Ethernet Network . . . . .	53
	Multiple EtherNet/IP Modules. . . . .	54
	Ethernet Communication . . . . .	54
	Domain Interactions. . . . .	54
	Controller Connections over the EtherNet/IP Network. . . . .	55
	Supported Functionality of the SoftLogix 5800 EtherNet/IP Module. . . . .	56
	Distributed Ethernet I/O . . . . .	56
	I/O Configuration Order in the Project . . . . .	56
	Ethernet I/O Data . . . . .	58
	Add a Remote Controller . . . . .	60
	Add a Consumed Tag. . . . .	61
	Check EtherNet/IP Statistics. . . . .	63
	Example 1: Workstation Remotely Connected to a SoftLogix Controller . . . . .	65
	Example 2: Send Messages over the EtherNet/IP Network. . . . .	68
	Configure a MSG Instruction. . . . .	69
	Example 3: Send Messages over the EtherNet/IP Network to a PLC-5 Processor . . . . .	71
	Configure a MSG Instruction. . . . .	71
	Example 4: Control Distributed I/O. . . . .	73
<b>Communicate with Serial Devices</b>	<b>Chapter 4</b>	
	Configure Your System for a Serial Device. . . . .	75
	Step 1: Configure the Serial Port . . . . .	76
	Change the COM Port Setting . . . . .	78
	Step 2: Configure the Serial Port of the Controller in the Project . . . . .	81
	Controller Status Indicators. . . . .	85
	Example 1: Workstation Directly Connected to a SoftLogix Controller . . . . .	85
	DF1 Point-to-Point Configuration. . . . .	86
	Example 2: Workstation Remotely Connected to a SoftLogix Controller . . . . .	86
	Master and Slave Communication Methods . . . . .	87
	DF1 Slave Configuration. . . . .	88
	DF1 Master Configuration . . . . .	88

	Example 3: SoftLogix Controller to a Bar Code Reader.....	90
	Connect the ASCII Device to the Controller .....	90
	User Mode Configuration.....	91
	ASCII Instructions .....	92
	<b>Chapter 5</b>	
<b>Configure and Use Simulated I/O</b>	Configure Your System for a 1789-SIM Module.....	93
	Step 1: Create the 1789-SIM Module in the SoftLogix Chassis Monitor .....	94
	Step 2: Configure the 1789-SIM module as Part of the Project ...	97
	Map I/O Data to the 1789-SIM Module .....	100
	Toggle Inputs and Monitor Outputs.....	101
	Turn On or Force a Bit .....	102
	Example: Move Application Data into the 1789-SIM Tags .....	103
	<b>Chapter 6</b>	
<b>Execute External Routines</b>	Configure Your System to Execute an External Routine .....	105
	Add an External Routine to the Controller Organizer.....	106
	How the Project Stores and Downloads an External Routine....	111
	Call an External Routine.....	112
	Jump to External Routine (JXR).....	112
	Operands .....	112
	Description .....	113
	Arithmetic Status Flags .....	113
	Fault Conditions .....	114
	Execution.....	114
	Type Checking .....	114
	<b>Chapter 7</b>	
<b>Develop External Routines</b>	Considerations For External Routines .....	115
	How the SoftLogix Controller Executes External Routines .....	116
	How the Project Stores and Downloads an External Routine....	117
	Create Synchronous, Single-threaded External Routines.....	117
	Create a Visual Studio Project .....	117
	Project Files .....	118
	RA_ExternalRoutines.h.....	119
	InlineExample.cpp.....	121
	InlineExample.h.....	122
	Create an HTML Resource .....	123
	Add Version Information to an External Routine DLL.....	128
	Build and Download External Routines .....	130
	Update an Existing External Routine .....	130
	Create Multi-threaded External Routines .....	130
	Sounds.cpp .....	131
	Thread Priorities in a Multithreaded External Routine DLL ...	135
	Debug External Routines .....	136

Set Up the Debug Session .....	136
Start a Debug Session .....	137
Set Breakpoints in External Routine Code .....	138
Data Type Support .....	138
ARRAY Example .....	139
INTEGER Example .....	140
STRUCTURE Example .....	141
STRING Example .....	142
Packing in Structures .....	143
Parameter Type Checking .....	144
Return Parameter .....	144
Export Functions by Using C++ Export Style .....	145
InlineExample.h .....	145
InlineExample.cpp .....	145
Run dumpbin.exe .....	145
Edit XML Resource .....	146
Other Considerations .....	147
Pass Tags by Reference .....	147
External Routine DLL that Uses Other DLLs .....	147

## Chapter 8

### Program Windows Events to Monitor and Change Controller Execution

Use Outbound Events .....	149
Programming Example: Outbound Events .....	150
Configure Windows Events to Launch Tasks within the SoftLogix Controller .....	153
Configure a Windows-event Task in the Controller .....	153
Trigger a Controller Task from a Windows Application .....	156
Programming Example: Windows Event .....	156
Programmatically Saving the Controller .....	158
Programming Example: Programmatic Save of Controller .....	158

## Appendix A

### Communicate with Devices on a DeviceNet Network

Configure Your System for a DeviceNet Network .....	162
Step 1: Install the Hardware .....	162
Step 2: Create the Communication Card in the SoftLogix Chassis Monitor .....	163
Step 3: Install the Communication Driver .....	166
Step 4: Configure the Communication Card as Part of the Project .....	169
Step 5: Download the Project to the Controller .....	171
Step 6: Define the Scanlist .....	172
Perform DeviceNet Test .....	181
Step 1: Start the Test Application .....	181
Step 2: Configure the Port .....	182
Step 3: Create a View .....	184
Step 4: Read Inputs and Write Outputs .....	186



	Step 5: Change the Scanner Mode .....	187
	DeviceNet I/O Data .....	188
	Determine How Often to Update Data .....	189
	Place the Communication Card in Run Mode.....	190
	CommandRegister Bits .....	190
	StatusRegister.....	191
	Status Data Elements .....	192
	Example: SoftLogix Controller and DeviceNet I/O .....	193
	Create Alias Tags.....	194
	 <b>Appendix B</b>	
<b>Communicate with Devices on a ControlNet Network</b>	Configure Your System for a ControlNet Network .....	195
	Step 1: Install the Hardware.....	196
	Step 2: Create the Communication Card in the SoftLogix Chassis Monitor.....	197
	Step 3: Configure the Communication Card as Part of the Project.....	200
	Step 4: Add Remote Communication Devices for the Communication Card .....	204
	Step 5: Download the Project to the Controller.....	211
	Step 6: Schedule the Network .....	213
	ControlNet I/O Data .....	219
	Rack-optimized Connections.....	220
	Direct Connections .....	221
	Example 1: SoftLogix Controller and ControlNet I/O .....	222
	Controlling I/O Modules .....	222
	Total Connections Required by the SoftLogix Controller.....	222
	Example 2: SoftLogix Controller to SoftLogix Controller .....	223
	Send a MSG Instruction .....	224
	Produce and Consume Tags.....	225
	Total Connections Required by the Soft1 Controller.....	228
	Example 3: SoftLogix Controller to Other Devices.....	228
	Send a MSG Instruction .....	229
	Produce and Consume Tags.....	230
Total Connections Required by the Soft1 Controller.....	233	
Example 4: Use the SoftLogix Controller as a Gateway .....	234	
	 <b>Appendix C</b>	
<b>Program Virtual Motion</b>	Virtual Motion Overview.....	237
	Logic for Motion Control .....	238
	Motion Faults.....	239
	Considerations When Running a Motion Application in Windows Operating System .....	240
	 <b>Appendix D</b>	
<b>Windows Considerations</b>	Observe Windows Objects.....	241

	Additional Considerations .....	242
	Run a SoftLogix Controller on the Windows Operating System .....	243
	Dwell Time Setting .....	243
	Periodic Tasks .....	244
	System Overhead Timeslice .....	247
	Multiple SoftLogix Controllers in the Virtual Chassis .....	247
	HMI Considerations .....	247
	Personal Computer Hardware Considerations .....	248
	 <b>Appendix E</b>	
<b>System Performance Tuning Guidelines</b>	Pre-qualify Your Personal Computer for Soft Control .....	249
	System Performance .....	252
	System Startup .....	253
	Monitor Personal Computer Performance .....	253
	 <b>Appendix F</b>	
<b>Status Indicators</b>	SoftLogix Controller Status Indicators .....	257
	Controller Status Indicator and Display .....	258
	SoftLogix EtherNet/IP Module Status Indicators .....	259
	Link Status (LINK) Indicator .....	259
	Network Status (NET) Indicator .....	260
	Module Status (OK) Indicator .....	260
	 <b>Appendix G</b>	
<b>SoftLogix 5800 Revision History</b>	SoftLogix 5800 Version 23 .....	261
	SoftLogix 5800 Version 21 .....	261
	SoftLogix 5800 Version 20 .....	261
<b>Index</b>		

Use this manual to become familiar with the SoftLogix™ 5800 controller and its features.

## Studio 5000 Environment

The Studio 5000 Engineering and Design Environment™ combines engineering and design elements into a common environment. The first element in the Studio 5000® environment is the Logix Designer application. The Logix Designer application is the rebranding of RSLogix™ 5000 software and will continue to be the product to program Logix5000™ controllers for discrete, process, batch, motion, safety, and drive-based solutions.



The Studio 5000 environment is the foundation for the future of Rockwell Automation® engineering design tools and capabilities. It is the one place for design engineers to develop all of the elements of their control system.

This manual is written to support SoftLogix software version 23.00.00 and the Logix Designer application. For SoftLogix software version 21 or earlier, substitute 'RSLogix 5000 software' for 'the Logix Designer application'.

## Additional Resources

These documents address the Logix5000 family of controllers and networks.

**IMPORTANT** We recommend that you read the appropriate release notes for software requirements, compatible PCI cards and driver, and system requirements.

To locate the release notes for your system, search for 1789-RN in the Rockwell Automation Literature Library, <http://www.literature.rockwellautomation.com>.

Resource	Description
Logix5000 Controllers Quick Start, publication <a href="#">1756-QS001</a>	Explains how to set up a Logix5000 controller.
Logix5000 Controllers Common Procedures, publication <a href="#">1756-PM001</a>	Describes how to complete standard tasks for Logix5000 controllers. Program logic by using sequential function chart (SFC), ladder diagram (LD), structured text (ST), and function block diagram (FBD) languages.
Logix5000 Controllers General Instruction Set Reference Manual, publication <a href="#">1756-RM003</a>	Program sequential applications, ladder diagram, and structured text instructions.
Logix5000 Controllers Process Control/Drives Instruction Set Reference Manual, publication <a href="#">1756-RM006</a>	Programming process control and drives applications and function block diagram instructions.
Logix5000 Controllers Motion Instructions Reference Manual, publication <a href="#">Motion-RM002</a>	Describes ladder diagram motion instructions so you can program motion applications.
SERCOS and Analog Motion Configuration and Startup, publication <a href="#">MOTION-UM001</a>	Provides general information about motion modules.
EtherNet/IP Network Configuration User Manual, publication <a href="#">ENET-UM001</a>	Describes how to use EtherNet/IP communication modules with your Logix5000 controller and communicate with various devices on the Ethernet network.
PhaseManager™ User Manual, publication <a href="#">LOGIX-UM001</a>	Describes how to set up a state model for your controller.

You can view or download publications at <http://www.literature.rockwellautomation.com>. To order paper copies of technical documentation, contact your local Allen-Bradley distributor or Rockwell Automation sales representative.

## SoftLogix 5800 System

Catalog Numbers 1789-L10, 1789-L30, 1789-L60

Topic	Page
About the SoftLogix 5800 Controller	13
Before You Begin	14
Install the SoftLogix 5800 Controller	15
FactoryTalk Activation Manager	16
Configure the RSLinx Virtual-backplane Driver	19

### About the SoftLogix 5800 Controller

The SoftLogix™ 5800 controller you use determines how many slots are available in the virtual chassis and how many devices you can install.

Controller	Maximum	Available Slots
1789-L10	<ul style="list-style-type: none"> <li>One SoftLogix 5800 controller</li> <li>Memory size limit of 2 MB per controller</li> <li>One 1784-SIM module</li> <li>EtherNet/IP support</li> <li>No third-party virtual-backplane module support</li> </ul>	3-slot virtual chassis <sup>(1)</sup>
1789-L30	<ul style="list-style-type: none"> <li>Two SoftLogix 5800 controllers</li> <li>Memory size limit of 64 MB per controller</li> <li>Five PCI network interface cards<sup>(2)</sup></li> <li>Five 1784-SIM modules</li> <li>EtherNet/IP support</li> <li>Third-party virtual-backplane module support</li> </ul>	5-slot virtual chassis
1789-L60	<ul style="list-style-type: none"> <li>Six SoftLogix 5800 controllers</li> <li>Memory size limit of 64 MB per controller</li> <li>Sixteen PCI network interface cards<sup>(2)</sup></li> <li>Sixteen 1784-SIM modules</li> <li>EtherNet/IP support</li> <li>Third-party virtual-backplane module support</li> </ul>	16-slot virtual chassis

(1) As of version 12 of the SoftLogix 5800 controller, the 1789-L10 controller supports three slots in the virtual chassis.

(2) The number of available slots in the virtual chassis is limited by the controller. You can have as many PCI communication cards as you have available slots in the virtual chassis and in the personal computer.

- 
- IMPORTANT**
- Motion control is not supported in SoftLogix software version 20.00.00 and later.
  - ControlNet, and DeviceNet modules are not supported in SoftLogix software version 21.00.00 or later.
  - SoftLogix software version 21.00.00 and later runs on these Windows operating systems:
    - Windows 7 Pro (32- and 64-bit)
    - Windows 7 Home Premium (32- and 64-bit)
    - Windows Server 2008 R2 Standard Edition with SP1
  - For system requirements of earlier versions of SoftLogix software, see the corresponding release notes.
  - Running the SoftLogix software in a Virtual Machine (for example, VMWare or VirtualBox), is not supported.
  - SoftLogix 5800 controllers and software do not support Integrated Motion on the EtherNet/IP network. SoftLogix software version 20.00.00 and later does not support any motion PCI cards.
  - No PCI-based cards are supported when using the Microsoft Windows 7 operating system.
  - The 1784-PCIDS card is not supported when using the Microsoft Windows 2008 Server operating system.
- 

## Before You Begin

Make sure you have the following software installed before you install SoftLogix software:

- Microsoft Windows 7 or Windows 2008 Server operating system
- RSLinx® Classic software

---

**IMPORTANT** We recommend that you read the appropriate release notes for system and software requirements, compatible PCI cards and driver, and system requirements. To locate the release notes for your system, search for 1789-RN in the Rockwell Automation Literature Library at <http://www.rockwellautomation.com/literature>.

---

---

**IMPORTANT** In Microsoft Windows Vista, Windows 7, and Windows Server 2008 operating systems, when RSLinx software is running as a service, the RSLinx driver configuration GUI is not available.

To invoke the RSLinx GUI, remove all SoftLogix controllers from the chassis monitor and use the RSLinx Control Panel to start RSLinx software as an application instead of a service.

---

Before you can install the SoftLogix 5800 controller, perform the following steps.

1. Log into the Windows operating system under an account that is a member of the Administrators user group on the computer where you are installing the SoftLogix 5800 controller.

To log in as a member of the Administrators group, your user account must be added to the Administrators group on the computer. Ask your system administrator if you need help.

2. Verify that the Windows Workstation and Server services required by the SoftLogix 5800 controller are running. The Workstation and Server services are automatically installed when you install Windows Networking or Remote Access Service (RAS).

---

**IMPORTANT** A machine running SoftLogix software does not support a remote desktop.

---

## Install the SoftLogix 5800 Controller

---

**IMPORTANT** If you have a previous version of SoftLogix software already installed on the computer, use Start>Control Panel>Programs and Features to remove the earlier version before installing the current version.

---

When you insert the installation DVD into your DVD ROM drive, the DVD automatically begins the set-up program for the controller. If your computer meets the hardware and software requirements for the controller, you can install the controller.

1. If RSLinx software is already running, shut it down before beginning this installation procedure.
2. Insert the SoftLogix 5800 installation DVD.
3. From the installation window, click SoftLogix 5800 V23.00.

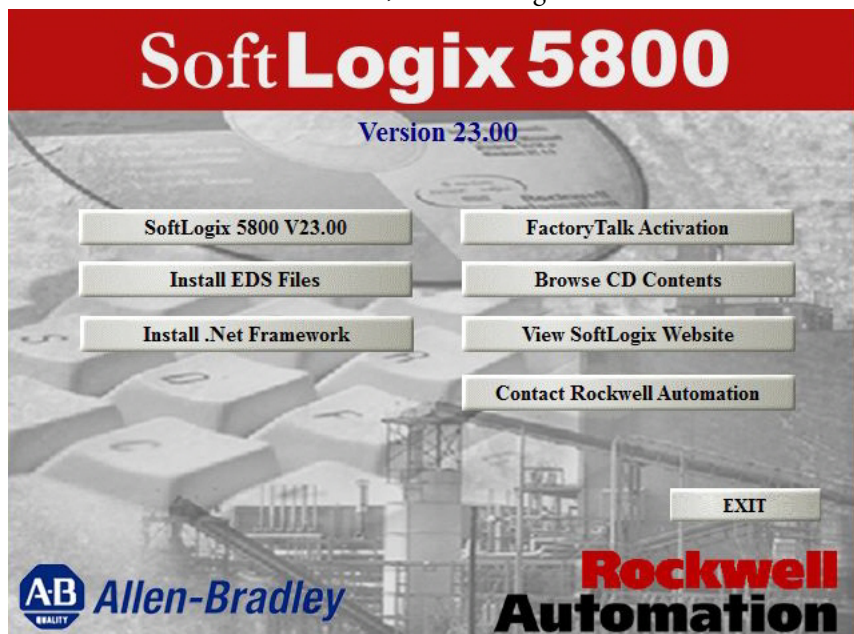

4. Follow the set-up wizard.

## FactoryTalk Activation Manager

There are two types of FactoryTalk® activations to activate the SoftLogix 5800 controller license—node-locked and concurrent.

### Node-locked Activation

Node-locked activation can be used only on the computer where the activation is locked (that is, on the personal computer for which the license was purchased). The activation is always locked to a specific piece of hardware, for example, an Ethernet card, a hard disk, or a USB dongle.

### Concurrent Activation

Concurrent activation is used in a server-client environment. This type of activation lets multiple computers across a network use Rockwell Automation software products concurrently. A concurrent activation can ‘float’ to, or be borrowed temporarily from, an activation server for a specific period of time before expiring and returning automatically to the pool of available activations on the server. Concurrent activations can be borrowed only if your Rockwell Software® product supports borrowed activations.

If you want to check out a concurrent activation from an activation server, you do not need to use the Rockwell Software Activation website. You can use the FactoryTalk Activation Manager to configure your client computer to recognize the activation server computer where concurrent activations are stored.

### Run the FactoryTalk Activation Manager

When you install the Studio 5000 environment, FactoryTalk Activation Manager is automatically installed on the computer where the activation needs to reside. The FactoryTalk Activation Manager software manages activations for the Rockwell Software products installed on the computer. The FactoryTalk Activation Manager opens automatically when you install a new Rockwell Software product.

You can also run the Activation Manager from the Windows Start menu by choosing Start>Programs>Rockwell Software>FactoryTalk Activation>FactoryTalk Activation Manager.

For more information about the FactoryTalk Activation Manager, refer to the online help in the software.



To activate your license, you need to have the host ID, serial number, and product key information available

Item	Description
Host ID	This is found by using the FactoryTalk Activation Manager. Choose Start>Programs>Rockwell Software>FactoryTalk Activation>FactoryTalk.
Serial Number	This is a 10-digit number supplied to you when you purchased your product.
Product Key	This is usually found in a red envelope that is shipped with your product.

To start activation, follow these steps:

1. Click 'Find Available Activations' or 'Get New Activations'.

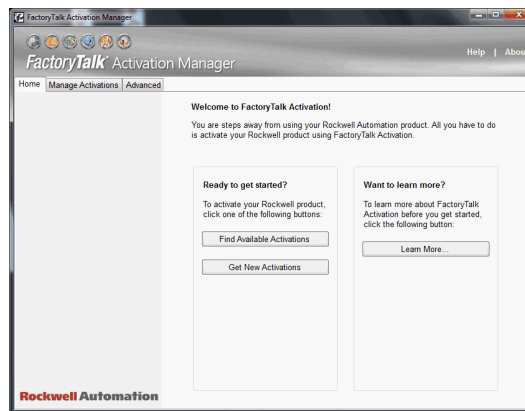

2. Follow steps 1...5 in the FactoryTalk Activation Manager.

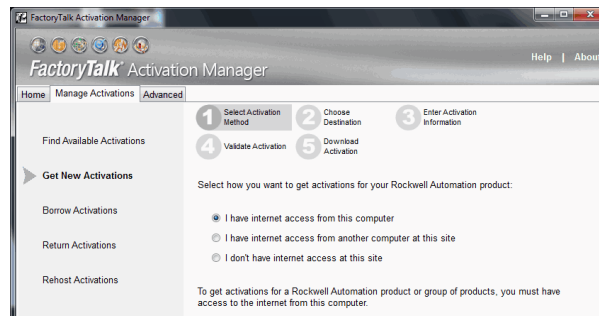

## Activation Tools and Rehosting

For information on Activation Tools and Rehosting Activations, see the Rockwell Software Activation website at <https://activate.rockwellautomation.com>.

## Troubleshoot FactoryTalk Activations

There could be several reasons you might have trouble installing your activations:

- If you accidentally requested too few concurrent activations for a product, you can download more new activations for the same Host ID. You cannot download more activations than you have purchased.
- To purchase additional activations, contact your local Rockwell Automation sales office.
- If you accidentally requested too many concurrent activations for a product, you must rehost all of the activations, and then request the correct number of activations again.
- For example, if you have 50 concurrent activations available for a product, and you intended to request 10 for a particular Host ID, but accidentally selected 13 in the Activations Requested list, you cannot return just the three activations you didn't want. You must rehost all 13 activations, and then download 10 activations to the correct Host ID.
- If you accidentally requested activations for the wrong Host ID (computer or dongle), you must rehost all of the activations you downloaded accidentally, and then request the activations again for the correct Host ID.
- If you accidentally requested activations for the wrong product, you must rehost all of the activations for that product, and then request the activations again.
- For example, if you accidentally requested five concurrent activations for Logix Designer application instead of FactoryTalk View SE software, you must rehost the five activations for Logix Designer application, and then download five activations for FactoryTalk View SE software.

To obtain more information, go to the Rockwell Automation Activations Support website at <https://activate.rockwellautomation.com>.

## Configure the RSLinx Virtual-backplane Driver

Use RSLinx software to configure the virtual-backplane driver. You do this only once for the computer.

**IMPORTANT** The RSLinx virtual-backplane driver is required for SoftLogix software to operate.

To install the virtual-backplane driver, follow these steps.

1. In RSLinx software, from the Communications menu, choose Configure Drivers.
2. From the Available Driver Type pull-down menu, choose Virtual Backplane Driver.

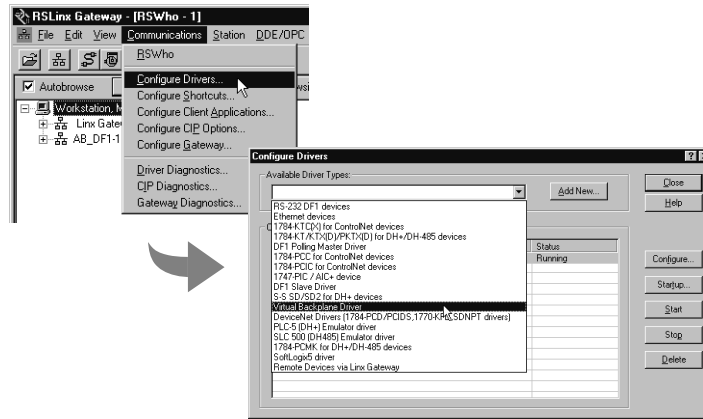

3. Click Add New.
4. Type the driver name, such as AB\_VBP-1, and click OK.

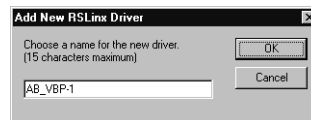

The Configure Drivers dialog box appears.

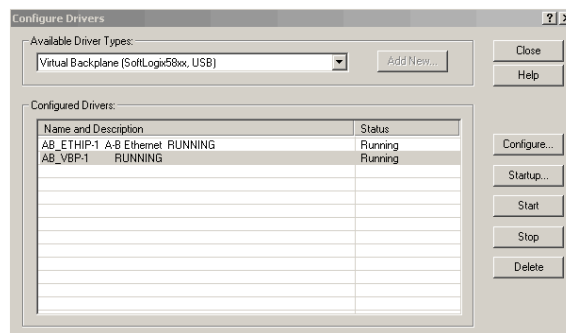

5. Click Configure.

The Configure VirtualBackplane dialog box appears. The Logix Designer application, version 23.00.00, lets you insert a valid SoftLogix module into slot 0.

The RSLinx software module defaults in Slot 0 if not set up for another slot position.

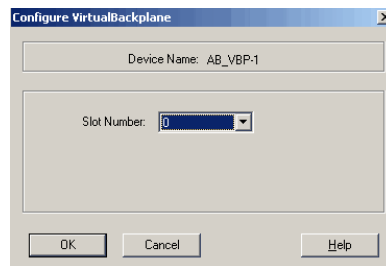

6. From the Slot Number pull-down menu, choose a slot number.

7. Click OK and then click Close.

---

**IMPORTANT**

Even if you remotely program the controller over a ControlNet or Ethernet link, you must add the virtual-backplane driver via RSLinx software. If you do not, the SoftLogix application will not be restored when you restart the computer.

---

## What is the SoftLogix System?

Topic	Page
SoftLogix System Components	22
Set Up the Chassis Monitor	24
Configure the SoftLogix Controller	27
Developing Programs	34
How the SoftLogix System Uses Connections	38
Connections for Produced and Consumed Tags	38
Connections for Messages	39
Connections for I/O Modules	40
Total Connection Requirements	40
Restart the Controller	41
Select a System Overhead Percentage	42

This chapter discusses SoftLogix controller options and characteristics. Procedures include how to configure your SoftLogix controller in the virtual chassis monitor for the first time and how to create your SoftLogix project in the Logix Designer application.

The SoftLogix system is a 'soft' control system that runs in Microsoft operating systems. The system resides on a computer, as opposed to a physical module in a hard chassis. For a list of the supported Windows operating systems, see the System Requirements section of the current release notes. The SoftLogix controller is part of the Logix environment and is a software-based controller that supports Logix instructions.

## SoftLogix System Components

A SoftLogix system can have these features, depending on the version of SoftLogix software. See chapter 1, Installation, and the Release Note for your version of SoftLogix software for specific information about which features are supported.

- The Chassis Monitor resides in the SoftLogix Virtual Chassis. It is a virtual 'soft' chassis as opposed to a physical chassis. It lets you create, delete, monitor, and configure controllers, communication interface cards, and motion cards in your SoftLogix system.
- The Studio 5000 environment supports every Logix controller. It provides the flexibility to program (online or offline) in ladder logic, function block diagram, structured text, and sequential function chart. It provides complete axis configuration and motion programming support.
- A SoftLogix 5800 controller is based on the Logix platform and takes control functions normally found in a dedicated programmable controller, encapsulates them in software, and runs them on a commercial operating system.
- The SoftLogix 5800 controller (version 19 and earlier) contains a high-speed motion task, which executes ladder motion commands and generates position and velocity profile information. The controller sends this profile information to one or more motion cards. Each controller can control up to 32 axes of motion.
- There are several controllers to choose from in the SoftLogix family, depending on your needs.
- SoftLogix software uses a commercially available Ethernet port for messaging and controlling I/O over an EtherNet/IP network.
- RSNetWorx™ software is a configuration tool that lets you control and schedule your network. RSNetWorx software can be used with a ControlNet network, a DeviceNet network, and an EtherNet/IP network.
- RSLinx software is a communication server that lets you configure communication devices for networks.
- IOLinx software lets the SoftLogix 5800 controller read I/O data.

### SoftLogix System Description

The Logix Designer application supports program development for all Logix controllers. The system can make a connection through a 1784-PCICS card via the ControlNet network, through a 1784-PCIDS card via the DeviceNet network, and through a standard Ethernet port via the EtherNet/IP network. SoftLogix software supports two types of motion cards; the 1784-PM02AE analog motion card and the 1784-PM16SE SERCOS motion card. See the release notes for your version of SoftLogix software to learn what features are supported.

Figure 1 - The SoftLogix System at a Glance

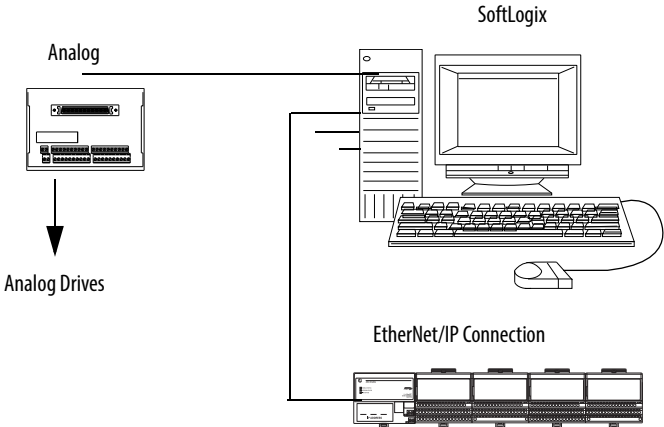

---

**IMPORTANT** Regardless of the product you have, choose 1789-L60/A in the Logix Designer application when you specify a controller type.

---

## Set Up the Chassis Monitor

The Chassis Monitor is your window into the SoftLogix system that lets you configure and monitor the system components. The Chassis Monitor models a physical chassis, but is virtual, or 'soft.' You install virtual devices in the virtual chassis to represent the controller and cards in your system.

An example of the SoftLogix Chassis Monitor is shown here.

### IMPORTANT

Treat the computer running a SoftLogix controller like an industrial controller and not a personal computer. A personal computer can perform many operations that are incompatible with the real-time operations required by a SoftLogix controller.

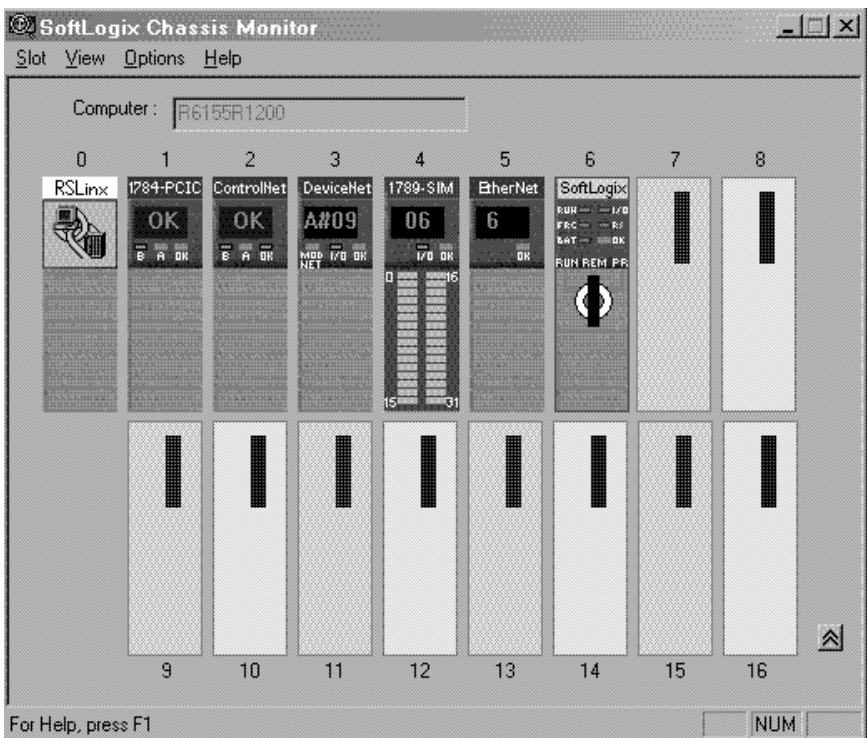

The Chassis Monitor is your SoftLogix controller interface. You use the simulated status indicators to view the status of the controllers in your system. You use the virtual chassis to do the following:

- Add and configure controllers
- Add and configure communication cards
- Change processor mode
- Monitor controller and associated module status
- Monitor motion performance



**Table 1 - Chassis Motor Characteristic**

Characteristic	Description
Startup mode	Specify how the controller should behave when its service is started. Select Remote Program (default) or Last Controller State.
Memory size	Specify the memory size (KB) to allow for the controller. The maximum limit depends on the controller type. See <a href="#">page 25</a> for more information.
Periodic save interval	Specify whether you want to save the current controller information (tag data values and configuration information) periodically, and if so, specify how often (minutes). Specify an interval between 0.5 . . . 30 minutes. Online edits to the program are saved instantly, regardless of Periodic Save interval. The default is enabled for 10 minutes. See <a href="#">page 26</a> about this setting's impact on overall system performance.
Continuous task dwell time (ms)	Specify the dwell time (0 . . . 1000 ms) made available for all other Windows applications. The default is 10 ms. The dwell time is the time between the end of the continuous task and the start of the next execution of the continuous task. This setting has an impact on overall system performance, see <a href="#">Appendix E</a> .
CPU affinity	If your computer has multiple Pentium CPUs, choose which CPU to use for this controller. The default is CPU 0.
Channel 0 serial port	Choose which COM port to use for serial communication. Choose COM1, COM2, COM3, or COM4. The default is none.

### Determine a Memory Size

**IMPORTANT** The memory size you specify is the amount of RAM in your computer that you want to allocate to the SoftLogix controller. The maximum memory size per controller is determined by the controller type.; see [page 25](#) for more information. This allocated RAM is not available to the Windows operating system or any other application.

These equations provide an estimate of the memory needed for a controller. Each of these numbers includes a rough estimate of the associated user programming. Depending on the complexity of your application, you might need additional memory. [page 22](#)

- Controller tasks**                    \_\_\_\_\_ \* 4000 = \_\_\_\_\_ bytes (min 1 needed)
- Discrete I/O points**            \_\_\_\_\_ \* 400 = \_\_\_\_\_ bytes
- Analog I/O points**                \_\_\_\_\_ \* 2600 = \_\_\_\_\_ bytes
- Communication modules**        \_\_\_\_\_ \* 2000 = \_\_\_\_\_ bytes
- Motion axis**                        \_\_\_\_\_ \* 8000 = \_\_\_\_\_ bytes
- Total** = \_\_\_\_\_ bytes

If you want to change the amount of memory you specified for a controller, you must first remove the controller from the SoftLogix chassis monitor, then reinstall the controller and specify the new memory size.

## Specify a Periodic Save Interval

The periodic save task executes at a priority of ‘user-mode high’. This means that the control process running within the SoftLogix 5800 controller will not be impacted by a periodic save, but other user applications will be impacted if they run at a priority lower than ‘user-mode high’. Most HMI applications run at a ‘user-mode normal’ priority. If these applications run on the same computer as the SoftLogix 5800 controller, these applications will be starved of CPU cycles while the periodic save is in progress. If you run an HMI application remotely and gather data from a SoftLogix 5800 controller via OPC, the performance of the HMI may also be impacted during a periodic save. The controller handles both the periodic save ‘tag value upload’ and HMI OPC requests through the same communication mechanism.

When the periodic save task executes, it performs these actions:

- For every tag defined within the controller, the current tag value is read from the controller.

The larger the amount of data, the longer the periodic save takes and the greater the impact on HMI responsiveness.

- The current tag values read earlier, along with the current program file, are saved to the computer disk drive.

The larger the archive file, the longer the periodic save takes and the greater the impact on HMI responsiveness. However, tag data size has more of an impact than archive file size.

To maintain better HMI responsiveness, you can do the following:

- Turn off the periodic save interval.

Even with the periodic save interval disabled, a periodic save occurs if a remote terminal performs an upload. This makes sure that the most current tag data values and archive file are uploaded.

If you disable the periodic save, you can still initiate a save manually by using the Save menu item on the controller from the Chassis Monitor or programmatically from an external routine or application. (See [Chapter 7](#)).

- Increase the periodic save interval so that it occurs less frequently.
- Use a dual CPU computer.

On a dual CPU computer, the Windows operating system automatically balances the periodic save and HMI applications across the CPUs.

For more information on system tuning and the periodic save interval, see [Appendix E](#).

## Configure the SoftLogix Controller

You must first create and configure your SoftLogix 5800 controller, that is, catalog number 1789-L10, 1789-L30, or 1789-L60, in the virtual chassis monitor.

### Step 1: Create and Configure the Controller in the SoftLogix Chassis Monitor

When you install a controller, the Chassis Monitor lets you configure specific characteristics about the controller. To configure the controller in the Chassis Monitor, follow these steps.

1. In the SoftLogix Chassis Monitor, from the Slot menu, choose Create Module.

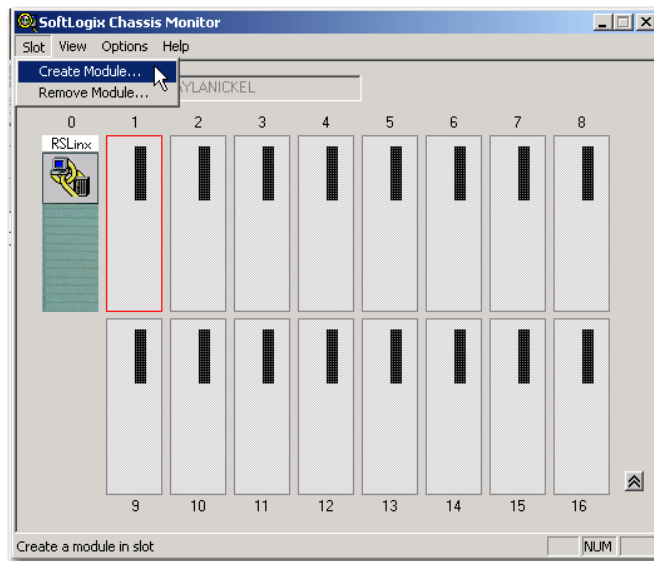

The Select Module dialog box appears.

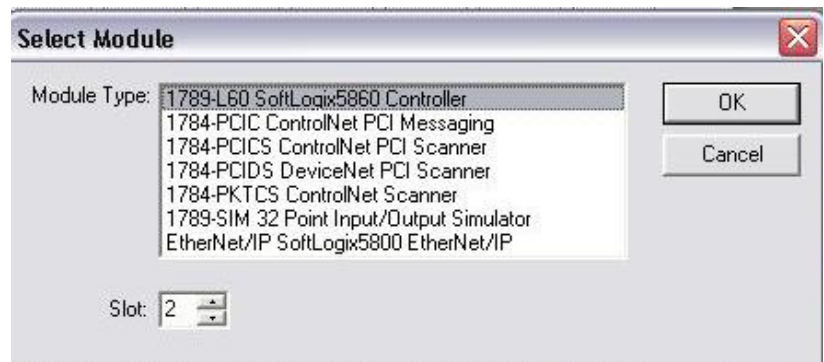

2. In the Select Module dialog box, select your module type and enter the Slot number.

RSLinx software defaults to slot 0, but you can move it to another slot if set up for this functionality. See [page 29](#).

For this example, we will enter slot 1 for the 1789-L60 SoftLogix 5800 controller.

3. Click OK.

The General dialog box appears.

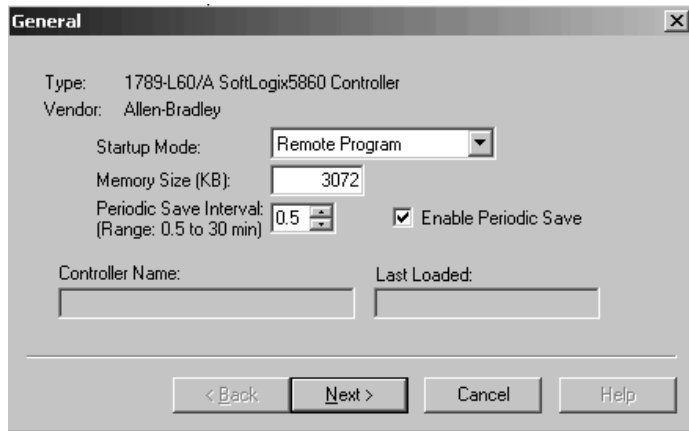

4. In the General dialog box, enter Startup Mode, Memory Size and Periodic Save Interval values.
5. Click Next.

The NT System dialog box appears.

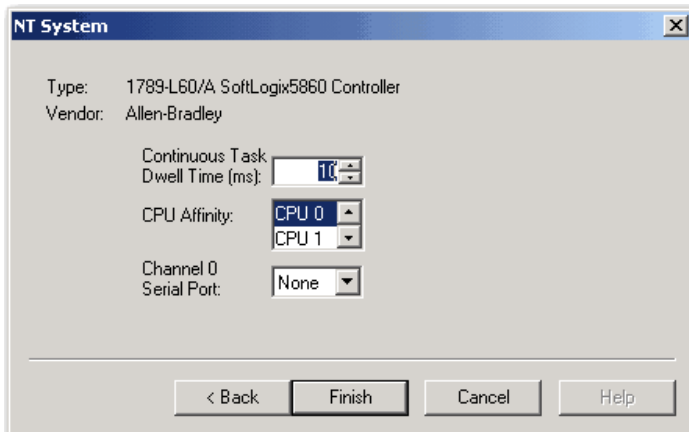

6. In the NT System dialog box, enter Continuous Task Dwell Time, CPU Affinity, and Channel Serial Port values.
7. Click Finish.

This SoftLogix Chassis Monitor now shows the new controller in slot 1.

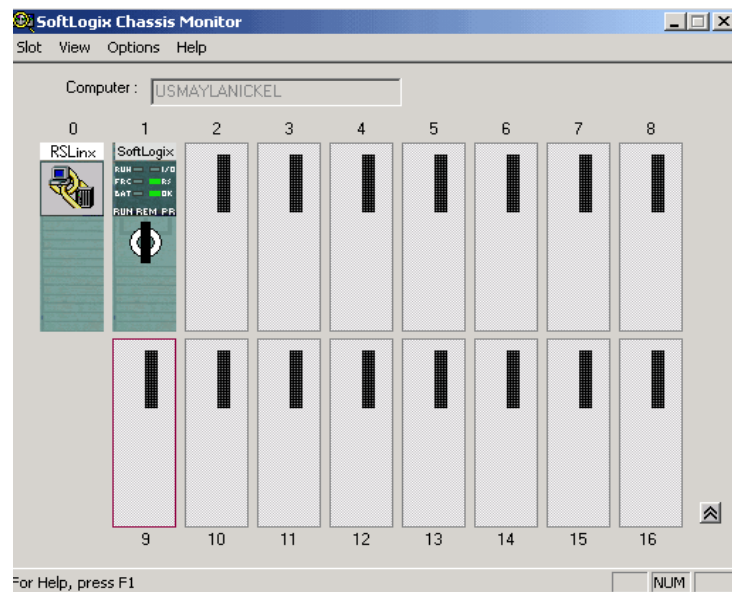

## Change the RSLinx Software Slot

The RSLinx software module automatically defaults to Slot 0 in the chassis. But you can program the virtual backplane to use the RSLinx module in another slot before starting up the SoftLogix application. This flexibility allows a SoftLogix module to be used in Slot 0 if so desired.

Complete these steps to set up RSLinx software, version 2.59.00 or later, in the chassis.

1. In RSLinx software, from the Communications menu, choose Configure Drivers.

The Configure Drivers dialog box appears.

2. From the Available Driver Types pull-down menu, choose Virtual Backplane.

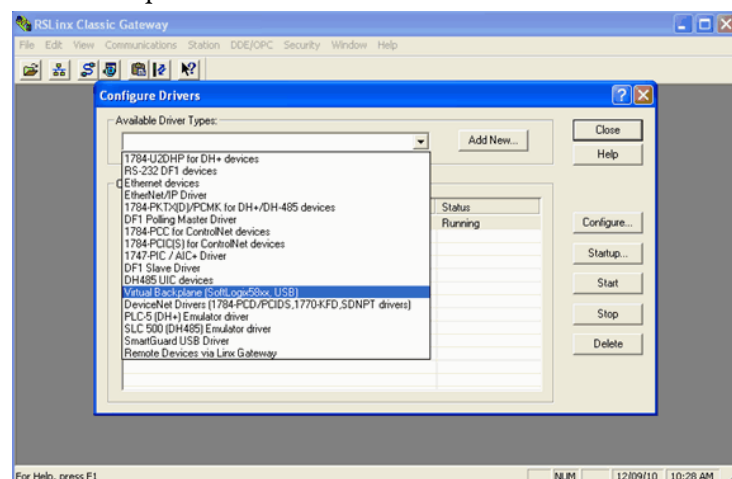

3. Click Add New and click OK.
4. Select AB-VBP-1 RSLinx Classic Driver from the list and click Configure.

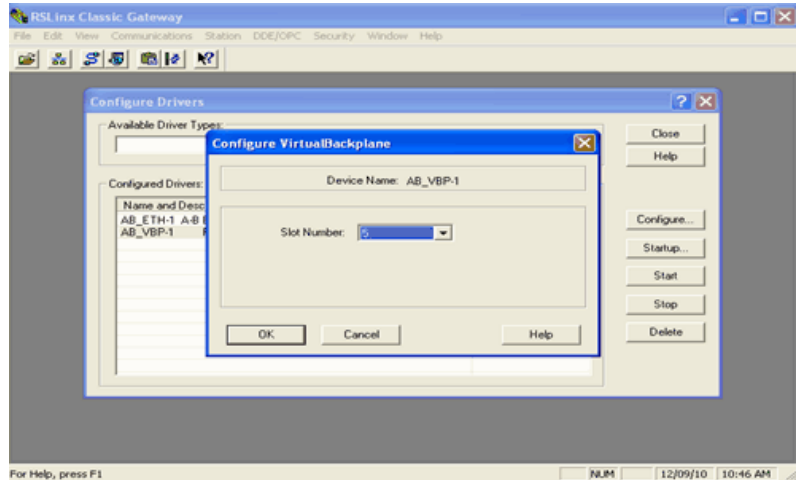

The driver must be running if SoftLogix is used. If the driver is deleted while SoftLogix is running after choosing a slot other than zero for the RSLinx module, RSLinx chooses the next available slot in the chassis monitor.

5. From the Slot Number pull-down menu, choose the slot for the RSLinx module.
6. Click OK and then click Close.

This SoftLogix Chassis Monitor now shows the RSLinx module in slot 5.

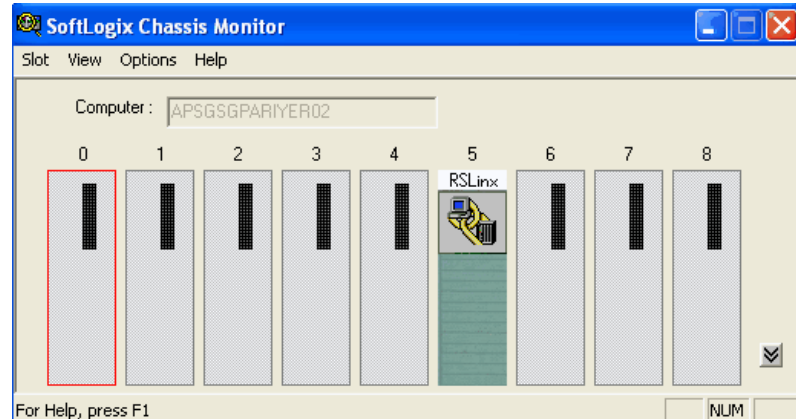

In addition to configuring your controller in the SoftLogix Chassis Monitor, you must create the controller as part of your Logix Designer project before you can configure and program it.

## Step 2: Create the New Controller Project in the Logix Designer Application

1. In the Logix Designer application, from the File menu, choose New.

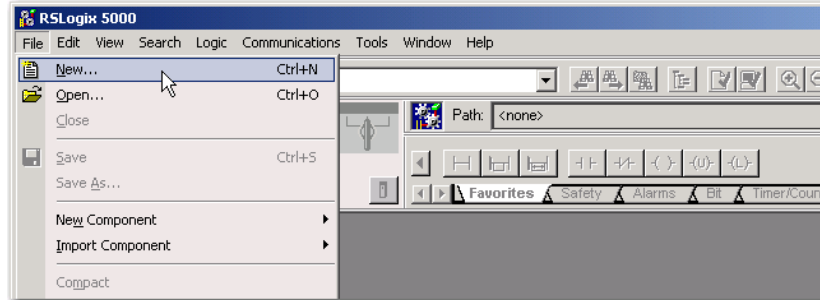

The New Controller dialog box appears.

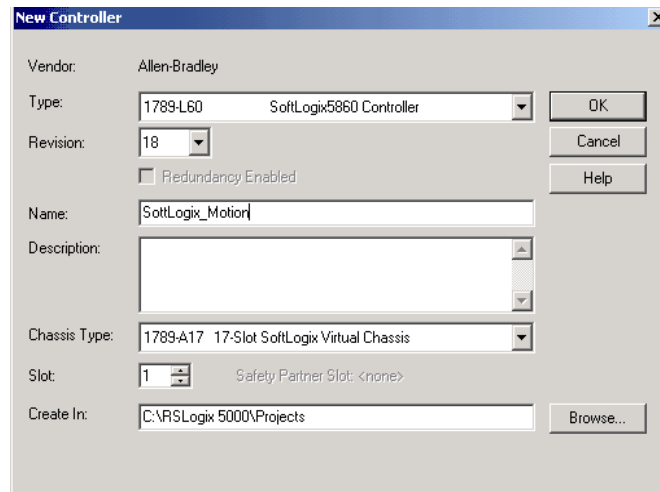

2. In the New Controller dialog box, from the Type pull-down menu, choose your SoftLogix controller.
3. Enter the controller Name, Chassis Type, and Slot Number to create the new controller project.

The example above shows the 1789-L60 controller in slot 1.

For Logix Designer application version 20.00.00 or later, slot 0 can be selected.

4. Click OK.

You now see the new controller in the Controller Organizer's I/O Configuration section of the Logix Designer application.

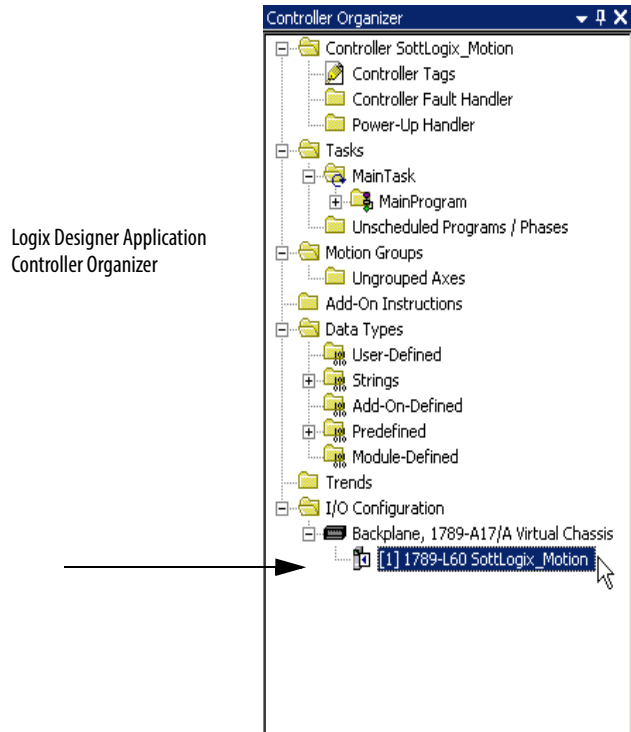

### Step 3: Configure the Controller in the Logix Designer Application Project

1. To configure the controller, in the Controller Organizer, from the I/O Configuration folder, right-click the new controller you just created and choose Properties.

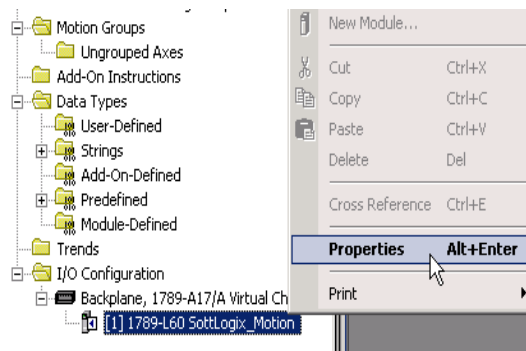



The Controller Properties dialog box appears.

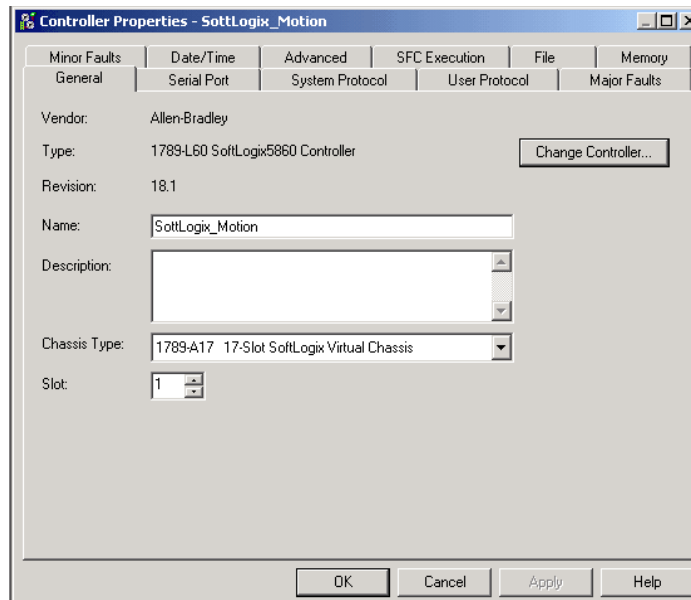

2. In the Controller Properties dialog box, set controller configuration information for the open project, and when online—for the attached controller.

The tabs that appear are particular to the type of controller you have selected.

3. Click OK when you are done configuring each tab for your controller.

For a complete description of each tab and the appropriate configuration settings for your SoftLogix controller, see the SERCOS and Analog Motion Configuration and Startup User Manual, publication [MOTION-UM001](#).

## Developing Programs

The controller's execution model is a preemptive, multitasking system that is IEC 1131-3 compliant. This environment provides the following:

- Tasks to configure controller execution
- Programs to group data and logic
- Routines to encapsulate executable code written in a single programming language

**Figure 2 - Control Application**

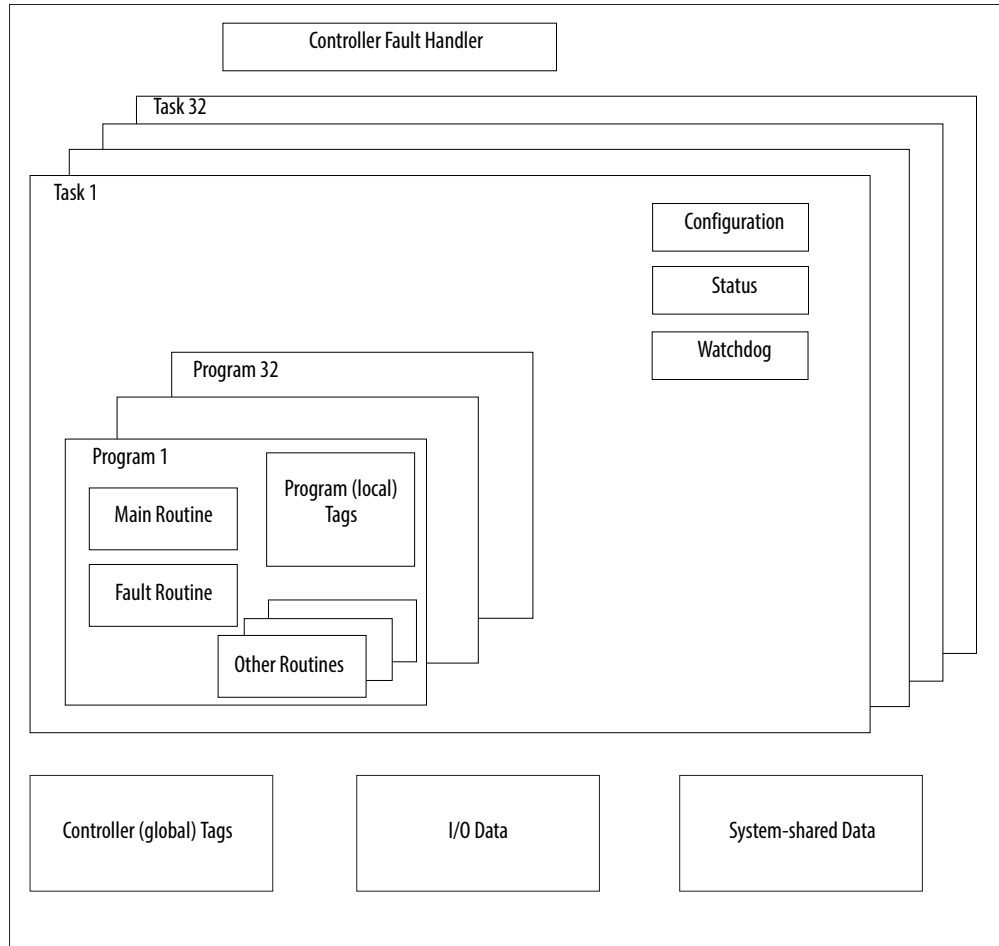

## Configuring Tasks

A task provides scheduling and priority information for a set of one or more programs. You can configure tasks as either continuous or periodic. The SoftLogix controller supports as many as 32 tasks, only one of which can be continuous.

A task can have as many as 32 separate programs, each with its own executable routines and program-scoped tags. Once a task is activated, all of the programs assigned to the task execute in the order in which they are grouped. Programs can appear only once in the Controller Organizer and cannot be shared by multiple tasks.

### *Setting Task Priorities*

Each task in the controller has a priority level. The controller uses the priority level to determine which task to execute when multiple tasks are triggered. There are 3 configurable priority levels for periodic tasks that range from 1...3, with 1 being the highest priority and 3 being the lowest priority. A higher priority task will interrupt any lower priority task. The continuous task has the lowest priority and is always interrupted by any periodic task.

The continuous-task dwell time determines how much time to allow for other Windows programs, running at a normal priority, to execute. The dwell time is the time between the end of the continuous task and the start of the next execution of the continuous task. The dwell time does not affect periodic tasks. Periodic tasks execute as scheduled, regardless of the dwell time. By default, the dwell time is 10 ms. This setting has an impact on overall system performance, see [Appendix E](#).

### *Tasks Based on Other Events*

The SoftLogix controller supports an additional Windows event trigger. This trigger lets you monitor Windows events in Windows 2000 or Windows XP operating systems so that applications outside of the SoftLogix controller can cause a task within the SoftLogix controller to execute. For more information, see [Step 3: Configure the Controller in the Logix Designer Application Project](#).

**Table 2 - Task Execution Order for Application with Periodic Tasks and Continuous Task**

Task	Priority Level	Task Type	Actual Execution Time	Worst Case Execution Time
1	1	20 ms periodic task	2 ms	2 ms
2	2	10 ms periodic task	4 ms	6 ms
N/A	None (lowest)	Continuous task	25 ms	35 ms
N/A	None	Dwell time	10 ms	14 ms

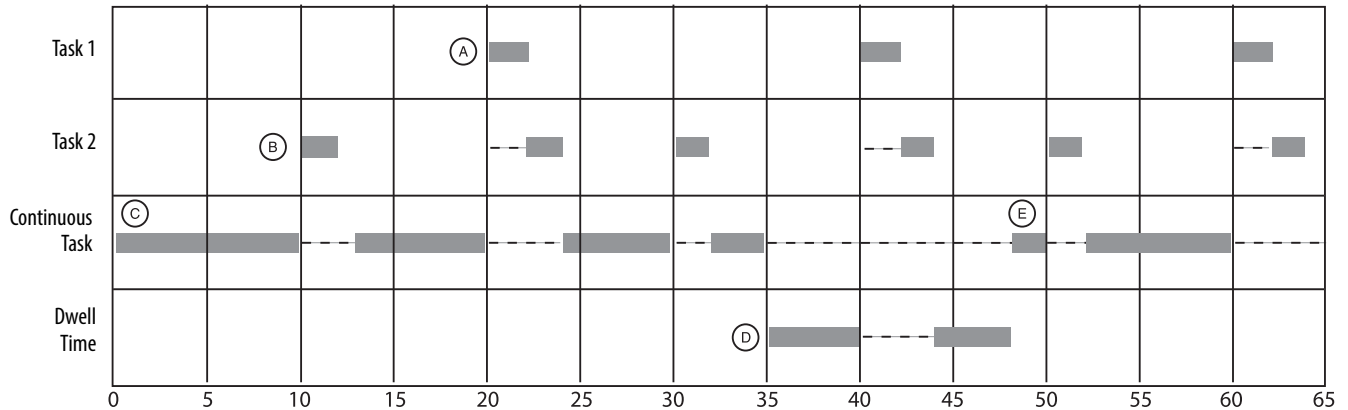

Task	Description
A	The highest priority task interrupts all lower priority tasks.
B	A lower priority task can be interrupted multiple times by a higher priority task.
C	The continuous task runs at the lowest priority and is interrupted by all other tasks.
D	The dwell time starts when the continuous task completes. The dwell time does not affect periodic tasks. Periodic tasks execute as scheduled, regardless of the dwell time.
E	The continuous tasks restart, when the dwell time completes, unless a higher priority task is running.

### Determining Programs

Each program contains program tags, a main executable routine, other routines, and an optional fault routine. Each task can schedule as many as 100 programs (including equipment phases).

The scheduled programs within a task execute to completion from first to last. Programs that are not attached to any task appear as unscheduled programs. You must specify (schedule) a program within a task before the controller can scan the program.

## Supporting Routines

A routine is a set of logic instructions in a single programming language, such as ladder logic. Routines provide the executable code for the project in a controller. A routine is similar to a program file or subroutine in a PLC or SLC™ processor.

Each program has a main routine. This is the first routine to execute when the controller triggers the associated task and calls the associated program. Use logic, such as the JSR instruction, to call other routines.

You can also specify an optional program-fault routine. The controller executes this routine if it encounters an instruction-execution fault within any of the routines in the associated program.

The SoftLogix 5800 controller supports routines developed with the relay ladder and function block editors of the Logix Designer application. You can edit relay ladder and function block routines either offline or online. You can also develop C/C++ routines and incorporate them into your project.

See [Chapter 5](#) for information on adding external routines to a project; see [Chapter 6](#) for information on developing external routines.

## Instruction Execution

When performing a math operation, the SoftLogix controller handles INT to REAL conversions differently than hardware-based Logix controllers. The SoftLogix controller completes the math operation by using the INT data and then converts the result to REAL data, which is more consistent with how math operations occur on personal computers. The hardware-based Logix controllers first convert INT data to REAL data and then perform the math operation.

The SoftLogix controller also handles the conversion of single-float values to double-float values differently than the ControlLogix controller. The personal computer processor calculates conversions to more decimal points than the ControlLogix controller. This can result in instructions operating differently between SoftLogix and ControlLogix controllers. For example, when calculating cam (MAPC) position with the MAPC instruction, the .PC bit can get set slightly sooner or later in a ControlLogix controller than in a SoftLogix controller. Factors that affect the time the .PC bit is set are as follows:

- Direction of travel
- Axis scaling constants of the two axes being used for the camming instruction
- The start and end point values used in the cam

## How the SoftLogix System Uses Connections

The SoftLogix system uses a connection to establish a communication link between two devices. Connections can be any of the following:

- Controller to local I/O modules or local communication modules
- Controller to remote I/O or remote communication modules
- Controller to remote I/O (rack-optimized) modules
- Produced and consumed tags
- Messages

You indirectly determine the number of connections the controller uses by configuring the controller to communicate with other devices in the system. Connections are allocations of resources that provide more reliable communication between devices than unconnected messages.

## Connections for Produced and Consumed Tags

The SoftLogix controller supports the ability to produce (multicast) and consume (receive) system-shared tags. System-shared data is accessible by multiple controllers over an EtherNet/IP network. Produced and consumed tags each require scheduled connections.

Tag Type	Required Connection
Produced	By default, a produced tag allows two other controllers to consume the tag, which means that as many as two controllers can simultaneously receive the tag data. The local controller (producing) must have one connection for the produced tag and the first consumer and one more connection for each additional consumer (heartbeat). The default produced tag requires two connections.  As you increase the number of controllers that can consume a produced tag, you also reduce the number of connections the controller has available for other operations, like communication and I/O.
Consumed	Each consumed tag requires one connection for the controller that is consuming the tag.

The SoftLogix controller supports a maximum of 127 consumed connections.

For two controllers to share produced or consumed tags, both controllers must be attached to the same network. You cannot bridge produced and consumed tags between two networks.

## Connections for Messages

Messages transfer data to other devices, such as other controllers or operator interfaces. Some messages use unscheduled connections to send or receive data. These connected messages can leave the connection open (cache) or close the connection when the message is done transmitting. This table shows which messages use a connection and whether you can cache the connection.

Message Type	Communication Method	Connection
CIP data table read or write	CIP	✓
PLC-2 <sup>®</sup> , PLC-3 <sup>®</sup> , PLC-5 <sup>®</sup> , or SLC (all types)	CIP	
	CIP with source ID	
	DH+™	✓
CIP generic	N/A	✓

Connected messages are unscheduled connections on both ControlNet and EtherNet/IP networks.

If a message executes repeatedly, cache the connection. This keeps the connection open and optimizes execution time. Opening a connection each time the message executes increases execution time.

If a message executes infrequently, do not cache the connection. This closes the connection upon completion of the message, which frees up that connection for other uses.

Each message uses one connection, regardless of how many devices are in the message path. To conserve connections, you can configure one message to read from or write to multiple devices.

You can cache as many as 16 messages (a combination of any type, not including block-transfer) at one time. If you try to cache more than 16, the controller determines the 16 most-currently used messages and caches those. If there are 16 messages cached, and a message is triggered that is currently not cached, the controller drops the connection of the oldest-cached message to make room for the new message.

In addition to 16 cached messages, you can also cache as many as 16 block-transfer messages. The same conditions apply to caching block-transfer messages as described above for caching other types of messages.

## Connections for I/O Modules

The SoftLogix system uses connections to transmit I/O data. These connections can either be direct connections or rack-optimized connections.

Connection	Description
Direct	A direct connection is a real-time, data transfer link between the controller and an I/O module. The controller maintains and monitors the connection between the controller and the I/O module. Any break in the connection, such as a module fault or the removal of a module while under power, causes the controller to set fault status bits in the data area associated with the module.
Rack-optimized	For digital I/O modules, you can choose rack-optimized communication. A rack-optimized connection consolidates connection usage between the controller and all of the digital I/O modules on a rack (or DIN rail). Rather than having individual, direct connections for each I/O module, there is one connection for the entire rack (or DIN rail).

To conserve the number of connections that are available, place digital I/O modules together in the same location and use a rack-optimized connection. To choose a rack-optimized connection, choose a 'rack-optimized' option for the communication format when you add the communication device and I/O modules to the controller project in the Logix Designer application.

If you have analog I/O modules, or want a direct connection to specific I/O modules, you do not have to create the rack-optimized connection to the communication device. To use direct connections to I/O modules, choose 'none' for the communication format of the communication device.

## Total Connection Requirements

The SoftLogix controller supports 250 connections. Each 1784-PCICS ControlNet communication card supports 128 total connections, 127 of which can be scheduled. Do not configure more connections than the controller can support. Use this table to tally ControlNet connections.

Table 3 - Connections

Connection Type	Device Quantity	Connections Per Device	Total Connections
Remote EtherNet/IP communication device (such as a 1794-AENT or 1756-ENBT module):			
• Configured as a direct (none) connection		0	
• Configured as a rack-optimized connection		1	
Remote I/O device over the EtherNet/IP network (direct connection)		1	
Produced and consumed tag:			
• Produced tag and one consumer		1	
• Each additional consumer		1	
Consumed tag		1	
Cached message		1	
<b>Total</b>			



## Restart the Controller

You restart the controller by either of these methods:

- Restarting the computer
- Removing and reinserting the controller in the virtual chassis

After restarting the controller, you must upload or download from the Logix Designer application before you can go online with the controller. This is because the project file (.ACD) contains explicit knowledge of the physical memory addresses used by the controller. When you restart the controller, all of the physical addresses for the controller are regenerated. Note that as long as the controller is not restarted, you can go online and offline as many times as required.

## Online with the Controller

You must save the Logix Designer application project after a download completes, or you will not be able to go online with the controller. After downloading, the physical address information has changed. The Logix Designer application prompts you to save and indicates that a change has occurred even though you might not have made changes to the project. Saving the project stores the physical address information into the ACD file.

An upload recovers all of the information that was downloaded to the controller, including documentation. This is because of the persistent storage feature that you enable by specifying a periodic save interval (see [page 26](#)). On a download, the persistent storage copies the entire project file to the controller. The controller opens and goes online with the project file so that any edits made by Logix Designer application workstations are saved into the persistent image (the controller's copy of the project file). Online edits are saved to the persistent image immediately; tag data values are saved to the persistent image at every periodic save interval (10 min default). If the periodic save is disabled, tag data values are not saved, but online edits are still saved to the persistent image.

The SoftLogix controller maintains a change log that holds 999 entries. This means that as you edit a Logix Designer project file, you must save the project file before you make 999 changes. If you make more than 999 changes to a project, you will not be able to go back online without performing an upload or a download.

## Upload to the Controller

If your project has edits and you want to upload the project to the controller, the Logix Designer application prompts you to save the project before uploading. Regardless of your choice, the edits are saved before the upload occurs. This happens because the edits are already stored in the controller as you make the edits.

## Select a System Overhead Percentage

The Controller Properties dialog box lets you specify a percentage of controller time (excluding the time for periodic tasks) that is devoted to communication and background functions.

1. In the Logix Designer application, from the Controller Organizer, right-click the controller and choose Properties.
2. Click the Advanced tab.
3. In the System Overhead Time Slice box, enter a percentage.

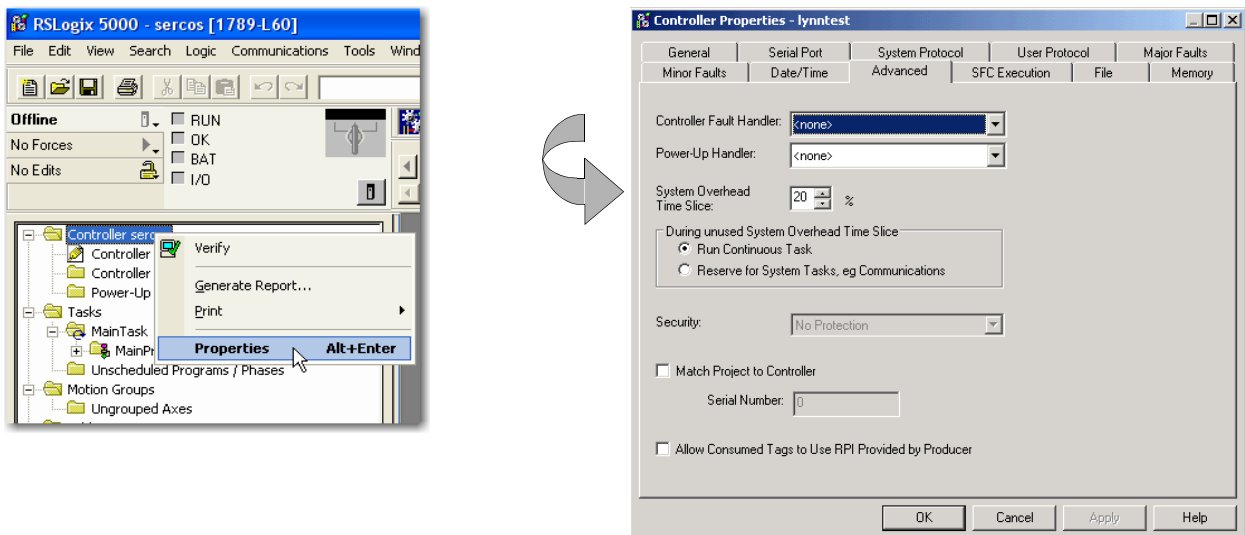

The system overhead function interrupts the continuous task. The percentage you specify determines the amount of the continuous task to allocate to system overhead functions, which include the following:

- Communicating with programming and HMI devices (such as RSLogix 5000 software)
- Responding to messages
- Sending messages, including block-transfers
- Re-establishing and monitoring I/O connections (such as RIUP conditions); this does not include normal I/O communication that occurs during program execution
- Bridging communication from one communication device to another communication device across the virtual chassis

This function allows the controller to take care of communication requests that occur from other controllers or from queued requests from within the controller's application program. If communication is not completing fast enough, increase the system overhead percentage.

Because the SoftLogix controller runs natively on your computer's Pentium CPU, the default setting of 10% yields satisfactory performance for most applications.

## Communicate with Devices on an Ethernet Network

Topic	Page
Configure Your System for an Ethernet Network	43
Multiple EtherNet/IP Modules	54
Controller Connections over the EtherNet/IP Network	55
Distributed Ethernet I/O	56
Add a Remote Controller	60
Check EtherNet/IP Statistics	63
Example 1: Workstation Remotely Connected to a SoftLogix Controller	65
Example 2: Send Messages over the EtherNet/IP Network	68
Example 3: Send Messages over the EtherNet/IP Network to a PLC-5 Processor	71
Example 4: Control Distributed I/O	73

This chapter explains how to communicate with a device on an Ethernet network by using the SoftLogix controller.

For information about communicating with EtherNet/IP devices, see the EtherNet/IP Network Configuration User Manual, publication [ENET-UM001](#).

### Configure Your System for an Ethernet Network

For the SoftLogix controller to operate on an EtherNet/IP network, you need the following:

- A computer where the SoftLogix controller resides enabled with an Ethernet communication port
- The Logix Designer application installed
- A computer where the Logix Designer application resides enabled with an Ethernet communication port
- RSLinx software installed

You can use any commercially-available Ethernet port. Use the Ethernet driver that comes with the device.

## Step 1: Disable UDP Messages in RSLinx Classic Software

To send messages, or control I/O, you must change the RSLinx Classic configuration so that it does not accept UDP messages.<sup>(1)</sup>

1. Launch RSLinx software on the computer with the controller.
2. From the View menu, choose Options.

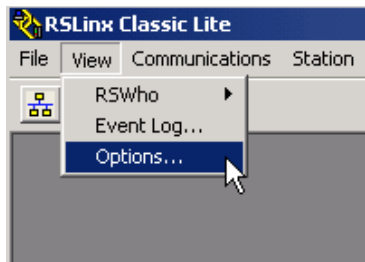

The Options dialog box appears.

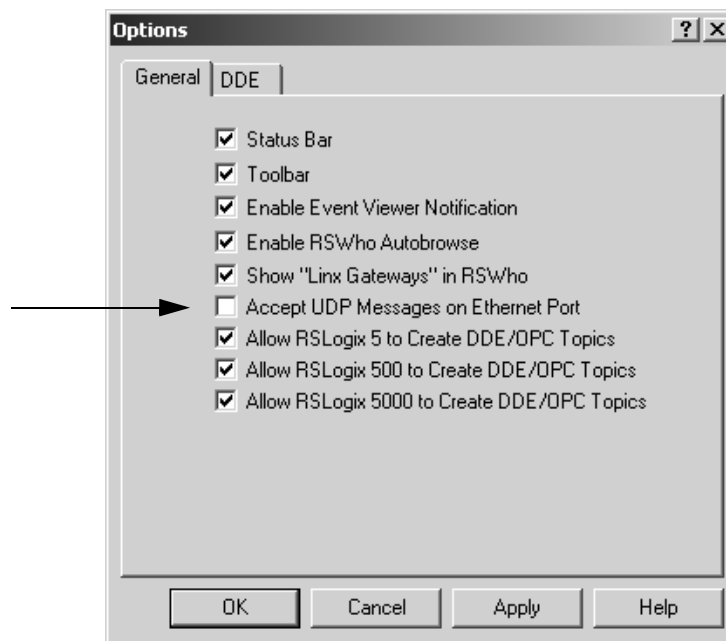

3. On the General tab, clear 'Accept UDP Messages on the Ethernet Port'.
4. Click OK.
5. Restart your computer.

(1) RSLinx Enterprise software may have other requirements. For details, see the MySupport Knowledgebase at <http://www.rockwellautomation.com/support>.

## Disabling the UDP option

Disabling the UDP option lets RSLinx software and the SoftLogix 5800 EtherNet/IP functionality coexist on the same personal computer. Disabling the UDP option also disables RSLinx software's Gateway functionality. RSLinx software still functions, but the Gateway options are removed while RSLinx software continues to display that it has a full Gateway activation. This affects how remote computers can browse through a local computer with UDP disabled.

If UDP is disabled on a local computer, a remote computer browsing through the local computer has this functionality:

- If the local computer has a DeviceNet module in the virtual chassis, you cannot remotely browse the DeviceNet network. Replacing RSLinx Lite with RSLinx Gateway software on the local or remote computer does not enable remote browsing of the DeviceNet network.
- If the local computer has a ControlNet module in the virtual chassis, you can remotely browse the ControlNet network.
- If the local computer has a SoftLogix controller in the virtual chassis, you can browse the serial port of the computer.
- If the local computer has an EtherNet/IP module in the virtual chassis, you can browse the EtherNet/IP network configured to that module.
- The local computer supports a remote connection to the SoftLogix controller over an Ethernet network so that you can remotely program the SoftLogix controller.

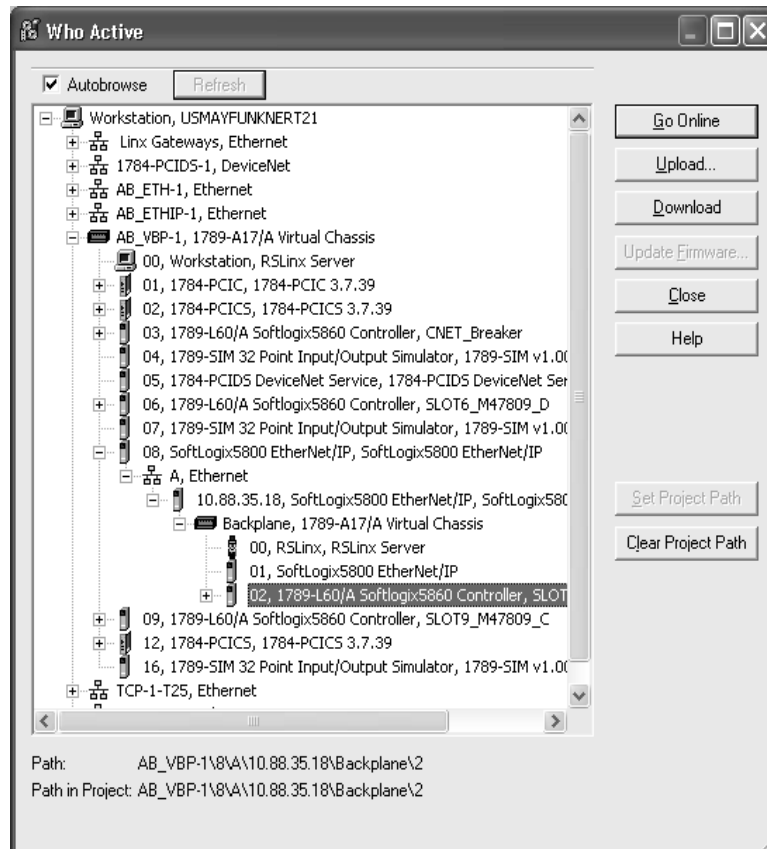

If UDP is disabled on a local computer, you can browse the ControlNet and EtherNet/IP networks and serial devices to see configured devices, as long as the appropriate module is installed in the virtual chassis on the local computer.

To be able to browse DeviceNet networks, RSLinx Gateway functionality (and therefore UDP) must be enabled on the computer that hosts the DeviceNet communication card.

## Enabling the UDP option

Enabling the UDP option lets the RSLinx Gateway functionality operate as expected. Installing a SoftLogix 5800 EtherNet/IP module into a system with the UDP option enabled and RSLinx Gateway functionality enabled, causes the SoftLogix EtherNet/IP module to display a red X in the chassis monitor. This does not affect the operation of the RSLinx software. It does prohibit the SoftLogix controller from sending and receiving messages and controlling I/O modules via an EtherNet/IP network.

Adding multiple Ethernet modules does not affect controller operation when UDP is enabled. Checking the Enable UDP box applies to all Ethernet ports on the computer; RSLinx Gateway software will use all of the Ethernet ports.

Enable the UDP option and the RSLinx Gateway functionality when you need the computer to configure or commission ControlNet and DeviceNet networks and devices. With the UDP option enabled, you have this functionality and loss of functionality in the computer where the controller resides:

- You must browse from the 1784-PCIDS driver in RSLinx software to browse a DeviceNet network.
- You can remotely browse the ControlNet network if there is a ControlNet module in the virtual chassis.
- You can browse over the serial port of the computer if there is a SoftLogix controller in the virtual chassis.
- You can remotely program the SoftLogix controller because the local computer supports a remote connection to the SoftLogix controller over an Ethernet network.
- If there is an EtherNet/IP module in the virtual chassis, it will not function as expected. You cannot control I/O or send messages.
- You can remotely program the SoftLogix controller because the local computer supports a remote connection to the SoftLogix controller over an Ethernet network.

If you want the UDP option enabled, you should also enable the Gateway functionality within RSLinx Gateway software. You must have RSLinx Gateway software to enable Gateway functionality. Follow these steps.

1. Launch RSLinx software on the computer with the controller.
2. From the Communications menu, choose Configure Gateway.

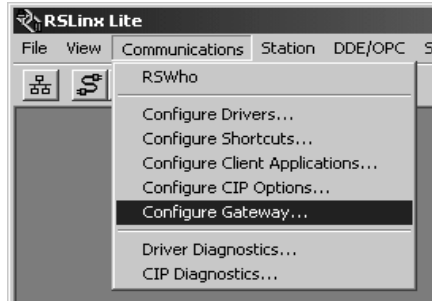

The Configure RSLinx Gateway dialog box appears.

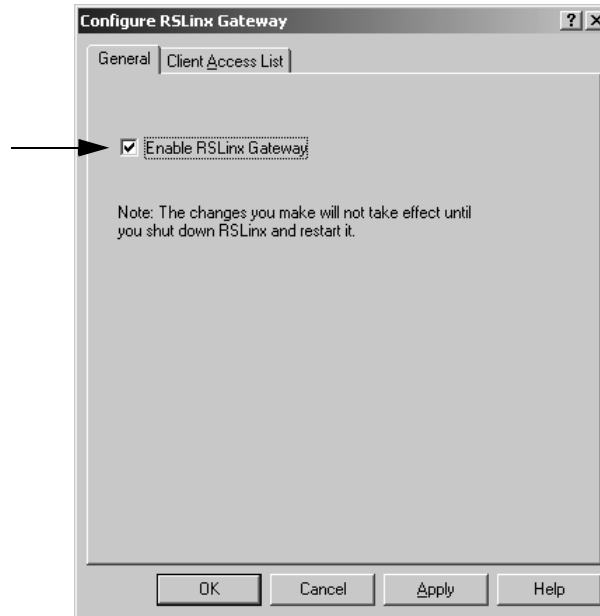

3. Check Enable RSLinx Gateway.
4. Click OK.

In many applications, initially leave UDP enabled so that you can configure ControlNet and DeviceNet networks. After configuration is done, disable UDP so the SoftLogix controller can have EtherNet/IP functionality. If you change the UDP setting, you must restart RSLinx software for the change to take affect. To restart RSLinx software, restart the computer.

For information on adding multiple Ethernet modules, see [page 54](#).

## Step 2: Create the Communication Card in the SoftLogix Chassis Monitor

Add the EtherNet/IP module to the SoftLogix virtual chassis if you are controlling I/O or sending messages over Ethernet network. These instructions show a SoftLogix controller installed already in slot 4. Follow these steps to add an EtherNet/IP module to your chassis.

1. In the SoftLogix Chassis Monitor, from the Slot menu, choose Create Module.

Or right-click the appropriate slot and choose Create.



The Select Module dialog box appears.

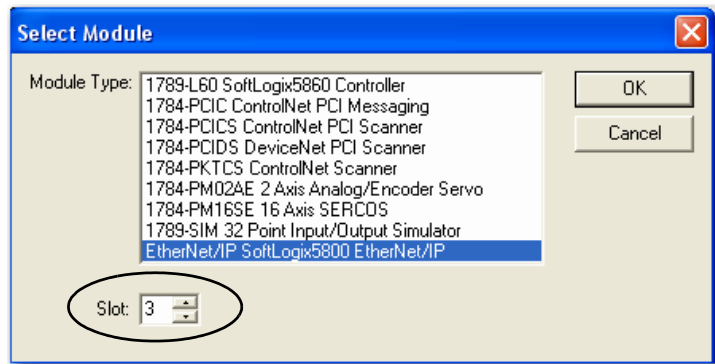

2. In the Select Module dialog box, select the EtherNet/IP SoftLogix 5800 EtherNet/IP communication module.
3. Enter the backplane slot number.

For the Logix Designer application, version 20.00.00 or later, you can specify any slot number for the communication card, as long as the RSLinx software module is positioned in a slot other than its default 0.

See [page 29](#).

4. Click OK.



The Select Device dialog box appears.



5. Select the serial number of the port you want.

If you previously had an Ethernet port configured in this slot, the chassis monitor remembers the configuration of that previous port.

6. Click Next.

The Module Properties General dialog box appears.

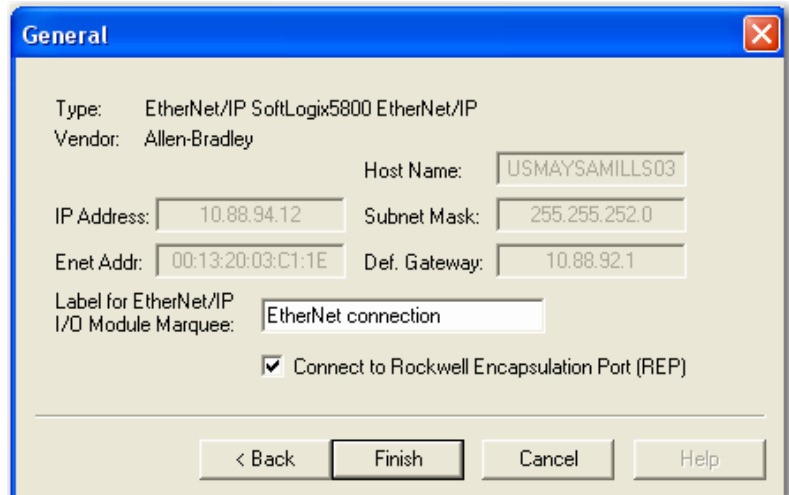

7. Specify a label name for the EtherNet/IP I/O Module Marquee.

The IP address, status, and the label name you enter here scrolls across the front of the module.

8. Click Finish.

This chassis monitor shows the selected IP address as a virtual module in the SoftLogix chassis.

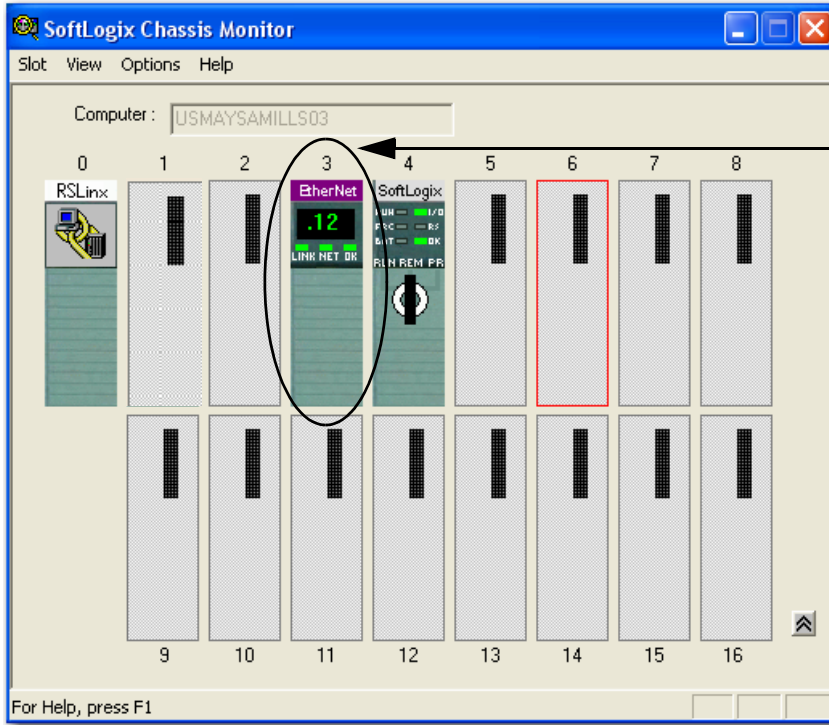

This chassis monitor has an EtherNet/IP module installed in slot 3.

### Step 3: Configure the Communication Card as Part of the Project

If you want to control I/O over an EtherNet/IP network, use the Logix Designer application to add the SoftLogix 5800 EtherNet/IP module to your project.

You should already have added the SoftLogix controller to the project.

See [Step 2: Create the New Controller Project in the Logix Designer Application on page 31](#).

Your controller is offline.

1. In the Logix Designer project, right-click the Ethernet module in the I/O Configuration folder, and choose New Module.

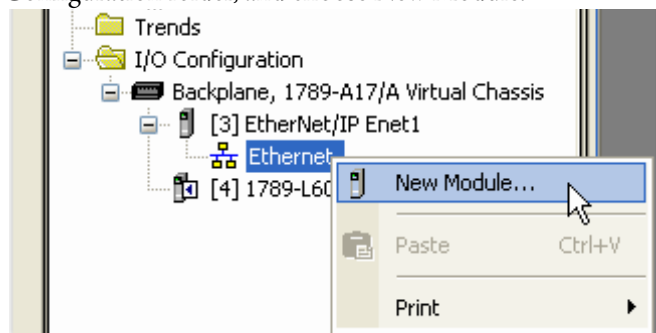

The Select Module dialog box appears.

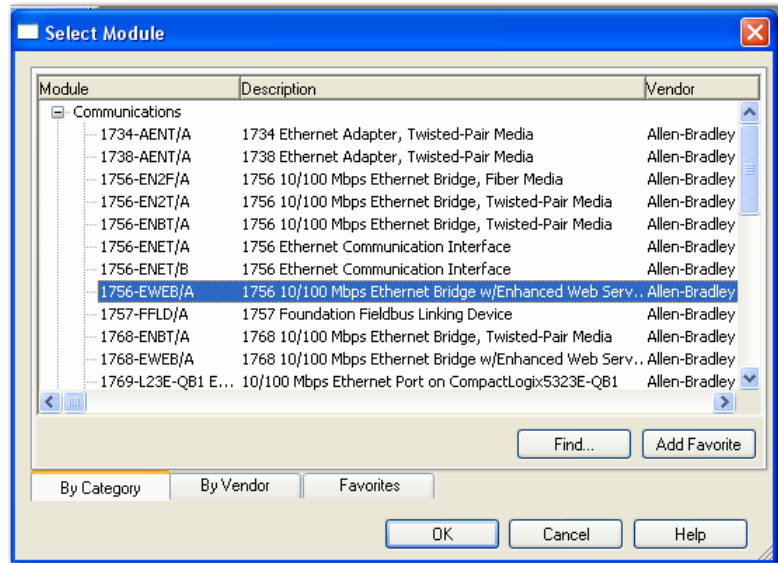

- Expand the Communications list and choose the 1756-EWEB/A module.
- Click OK.

The Select Major Revision dialog box appears.

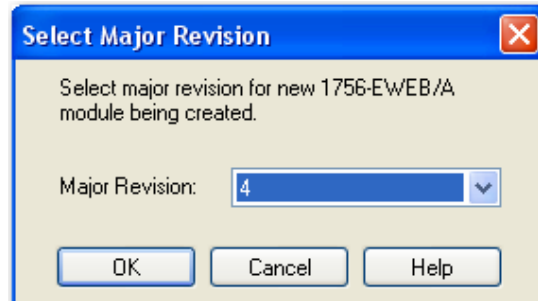

- From the Major Revision pull-down menu, choose the revision number and click OK.

The Module Properties dialog box appears.

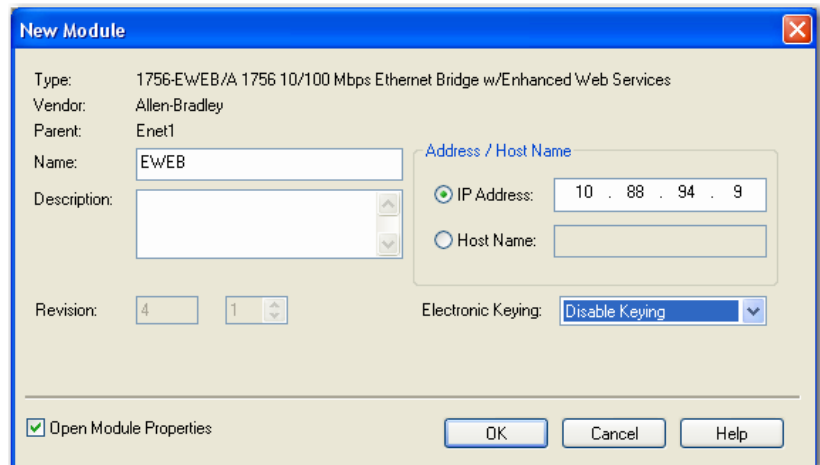

5. Name the module, enter the IP address, and select the Disable Keying option.
6. Click OK.

The Module Properties dialog box appears.

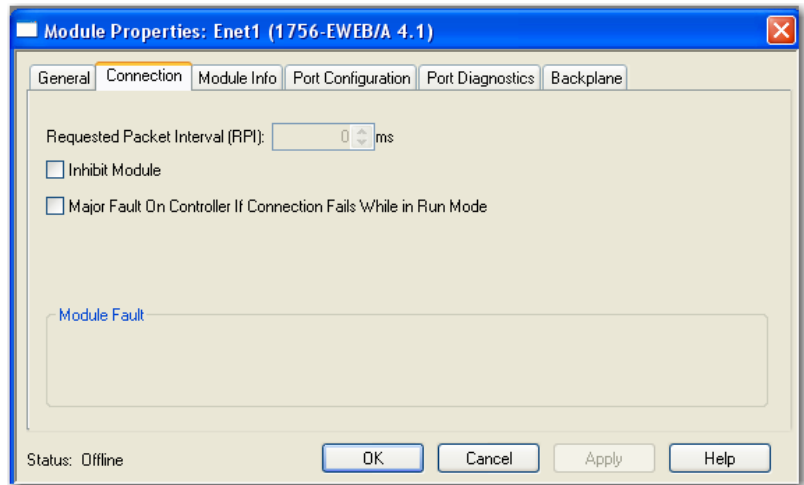

## Step 4: Configure the SoftLogix EtherNet/IP Module to Communicate on an Ethernet Network

Configuring a SoftLogix 5800 EtherNet/IP module is similar to configuring a 1756-ENBT module in a ControlLogix project, except for these differences:

- If the SoftLogix 5800 EtherNet/IP module is in the same virtual chassis as the SoftLogix controller, you do not have to enter an IP address. The configuration defaults to the IP address of the computer.
- If there are multiple IP addresses, or if the SoftLogix 5800 EtherNet/IP module is not in the same virtual chassis as the SoftLogix controller, you must enter an IP address. This is similar to configuring a 1756-ENBT module.
- A 1756-ENBT module requires that you choose a communication format. This is not required for a SoftLogix 5800 EtherNet/IP module.

Refer to the EtherNet/IP Network Configuration User Manual, publication [ENET-UM001](#), for more information on configuring the 1756-ENBT module. The SoftLogix module is configured the same way.

When you have completed configuration, click OK and save the project.

Your Logix Designer application project's I/O configuration folder should now look similar to this example.

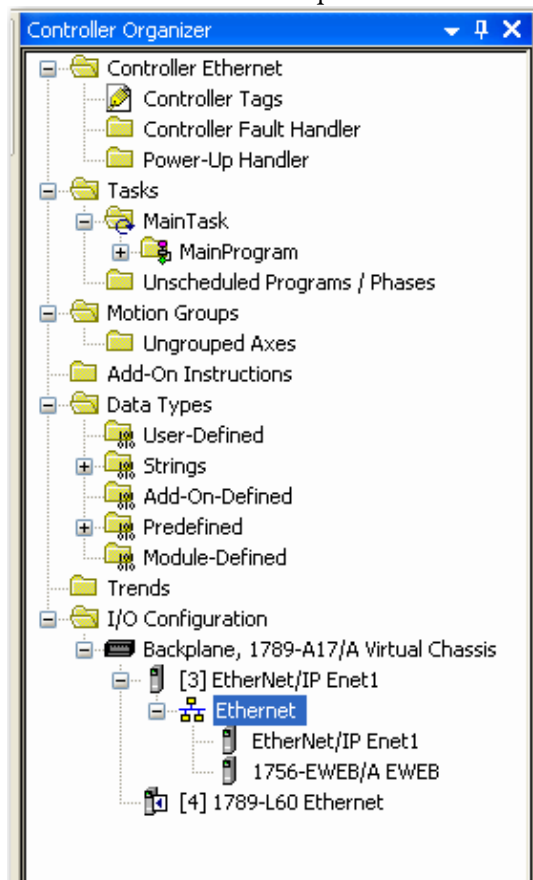

## Multiple EtherNet/IP Modules

If the computer has multiple IP addresses available, you can install multiple Ethernet modules in the virtual chassis. Choose the appropriate IP address when you configure the EtherNet/IP module in the virtual chassis.

The configuration you choose for the UDP option in RSLinx software applies to every IP address on the same computer. RSLinx software does not support separate UDP configurations per IP address or actual Ethernet device. If you enable UDP functionality in RSLinx software, RSLinx software consumes all IP addresses on the computer.

### Ethernet Communication

With multiple Ethernet modules, the SoftLogix 5800 controller can receive an I/O connection error due to conflicting naming conventions with Windows operating systems. To avoid this, place all of the following:

- Produced and consumed tags and I/O devices on one Ethernet module.
- MSG instructions on a different Ethernet module.

To connect to the Ethernet network, launch RSLinx software.

### Domain Interactions

In a system with multiple Ethernet modules, you can connect to different networks. For example, this multi-homing system has two Ethernet modules.

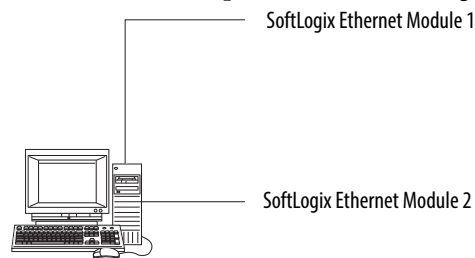

Item	Description
1	Ethernet module 1 connected to the corporate network <ul style="list-style-type: none"> <li>• Member server in the domain</li> <li>• Searches for name and DNS information</li> <li>• Dynamic configuration</li> </ul>
2	Ethernet module 2 connected to the plant network <ul style="list-style-type: none"> <li>• No existing domain control</li> <li>• DNS not available</li> <li>• Static configuration</li> </ul>

In this example, because Ethernet module 1 is dynamically configured, Ethernet module 2 is unable to get routing information to a gateway and cannot successfully send or receive multicast packets.

Possible solutions include the following.

Solution	Description
Multi-homed Windows 2003 member server on active directory or mixed domain	Connect both Ethernet modules to domain controllers so that they both receive correct routing information.
Multi-homed personal computer not connected to a domain and set up in a work group.	Configure both Ethernet modules with correct IP address information by using either a DHCP server or by static IP address assignment. When IP address information is assigned to the Ethernet modules, the modules do not have to independently determine domain relationships.

---

**IMPORTANT** If you have multiple networks, you must have gateways configured to reach those networks.

---

## Controller Connections over the EtherNet/IP Network

A Logix system uses a connection to establish a communication link between two devices. Connections can be the following:

- Controller to distributed I/O or remote communication modules
- Produced and consumed tags
- Messages

All EtherNet/IP connections are unscheduled. An unscheduled connection is a message transfer between controllers that is triggered by the requested packet interval (RPI) or the program (such as an MSG instruction). Unscheduled messaging lets you send and receive data when needed.

Over EtherNet/IP network, the SoftLogix controller supports the following:

- 64 TCP/IP connections for EtherNet/IP communication
- 1 single TCP connection can support multiple CIP connections
- 128 CIP connections for Logix-based communication

A CIP connection transfers data from one Logix application running on one end-node to a second Logix application running on another end-node. A CIP connection is established over a TCP connection.

## Supported Functionality of the SoftLogix 5800 EtherNet/IP Module

Compared to a 1756-ENBT EtherNet/IP module in a ControlLogix system, the SoftLogix 5800 EtherNet/IP module does the following:

- Supports the same number of I/O connections
- Supports the same number of messaging connections
- Supports the same bridging functionality
- Supports an EtherNet/IP statistics utility (see [page 63](#))
- Does not support a web-based interface
- Does not support email via MSG instruction

## Distributed Ethernet I/O

The SoftLogix controller supports distributed I/O over an EtherNet/IP network. Use the Logix Designer application to add the SoftLogix 5800 EtherNet/IP module for the local controller; then add a remote adapter and I/O modules to the I/O Configuration folder of the controller project.

### I/O Configuration Order in the Project

This example shows a typical SoftLogix distributed I/O network.

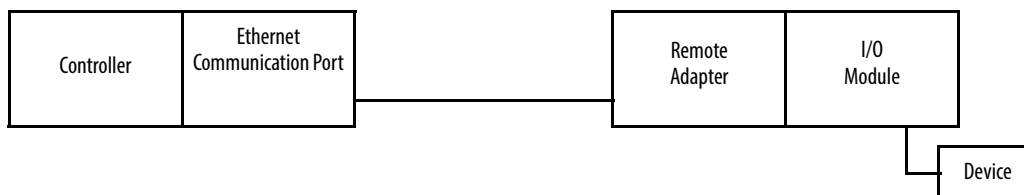



You build the I/O configuration in this order.

1. Add (see [page 50](#)) the remote adapter to the SoftLogix 5800 EtherNet/IP module of the controller (1794-AENT/A remote\_flex\_adapter).

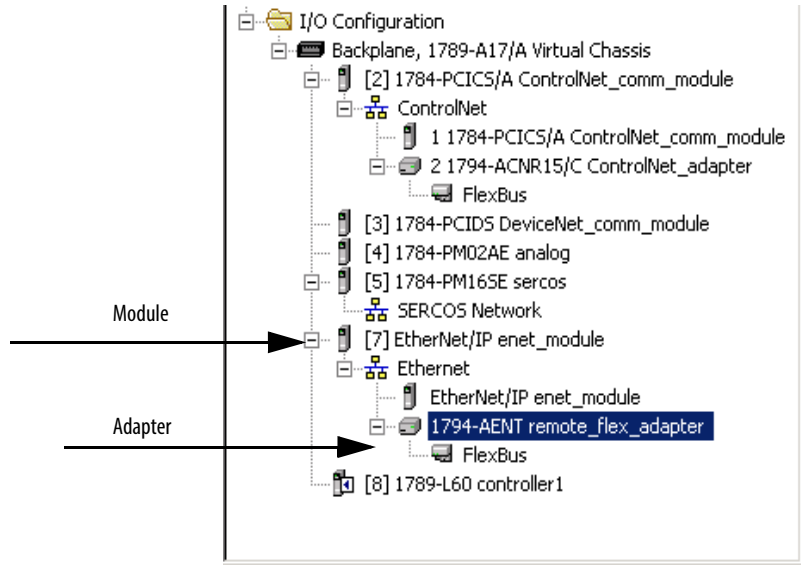

2. Add (see [page 50](#)) the I/O modules to the remote adapter (1794-IA16/A remote\_flex\_input, 1794-CB16/A remote\_flex\_output, 1794-IF2XOF2I/A remote\_flex\_combo).

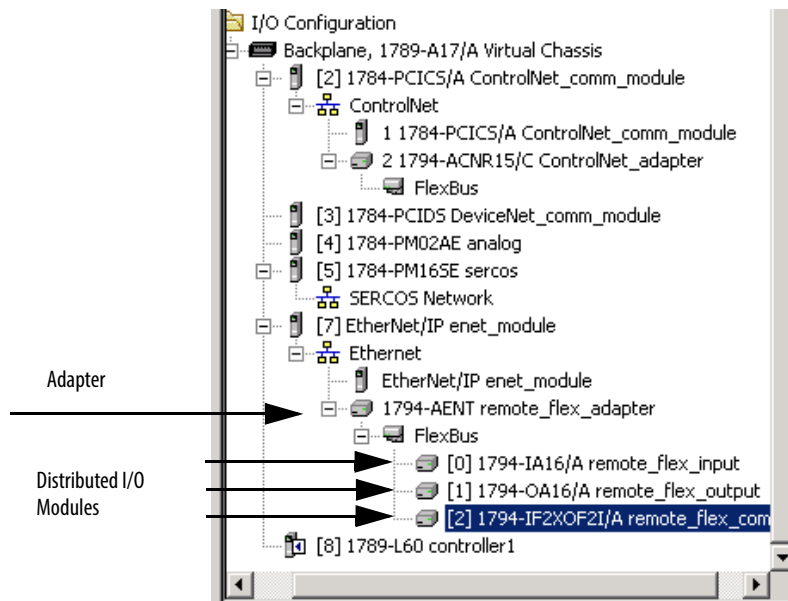

## Ethernet I/O Data

I/O information is presented as a structure of multiple fields, which depend on the specific features of the I/O module. The name of the structure is based on the location of the I/O module in the system. Each I/O tag is automatically created when you configure the I/O module through the programming software. Each tag name follows this format:

Location:SlotNumber:Type.MemberName.SubMemberName.Bit

This address variable	Is
Location	Identifies network location ADAPTER_NAME = identifies remote adapter or bridge
SlotNumber	Slot number of I/O module in its chassis
Type	Type of data I = input O = output C = configuration S = status
MemberName	Specific data from the I/O module; depends on the type of data the module can store. For example, Data and Fault are possible fields of data for an I/O module. Data is the common name for values the are sent to or received from I/O points.
SubMemberName	Specific data related to a MemberName.
Bit (optional)	Specific point on the I/O module; depends on the size of the I/O module (0 . . . 31 for a 32-point module)

See this example.

**EXAMPLE**

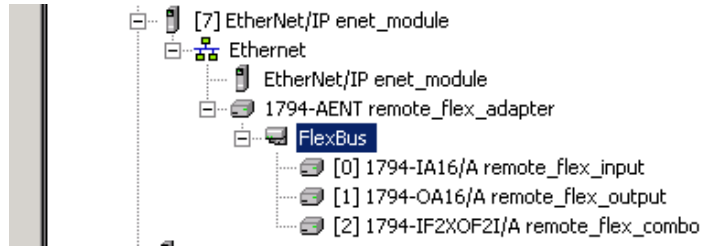

Device	Example Tag Names (automatically created by the software)
remote adapter 'remote_flex_adapter'	remote_flex_adapter:I remote_flex_adapter:I.SlotStatusBits remote_flex_adapter:I.Data remote_flex_adapter:O remote_flex_adapter:O.Data
'remote_flex_input' in slot 0 rack-optimized connection	remote_flex_adapter:0:C remote_flex_adapter:0:C.Config remote_flex_adapter:0:C.DelayTime_0 remote_flex_adapter:0:C.DelayTime_1 remote_flex_adapter:0:C.DelayTime_2 remote_flex_adapter:0:C.DelayTime_3 remote_flex_adapter:0:C.DelayTime_4 remote_flex_adapter:0:C.DelayTime_5 remote_flex_adapter:0:I
'remote_flex_output' in slot 1 rack-optimized connection	remote_flex_adapter:1:C remote_flex_adapter:1:C.SSDData remote_flex_adapter:1:O remote_flex_adapter:1:O.Data
'remote_flex_combo' in slot 2 direct connection	remote_flex_adapter:2:C remote_flex_adapter:2:C.InputFilter remote_flex_adapter:2:C.InputConfiguration remote_flex_adapter:2:C.OutputConfiguration remote_flex_adapter:2:C.RTSInterval remote_flex_adapter:2:C.SSCh00uputData remote_flex_adapter:2:C.SSCH10OutputData remote_flex_adapter:2:I

## Add a Remote Controller

If you want this controller to consume tags from another controller via Ethernet, add the controller to the EtherNet/IP module. The consumer initiates any actions.

To add a remote controller, build the I/O configuration in this order.

1. Add the devices to the EtherNet/IP port of the controller.

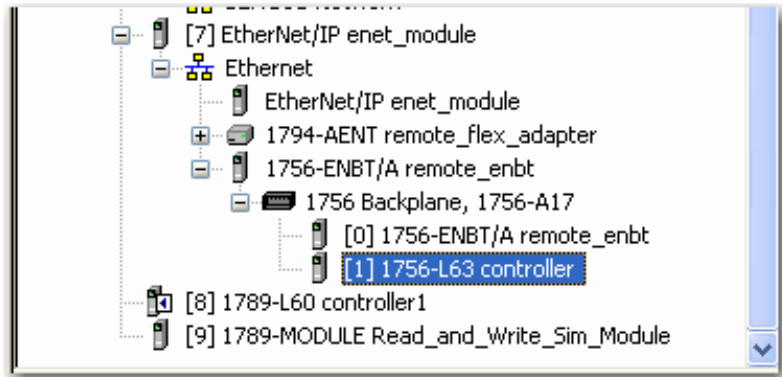

2. For a controller that requires a communication module, add the module first, and then add the controller.

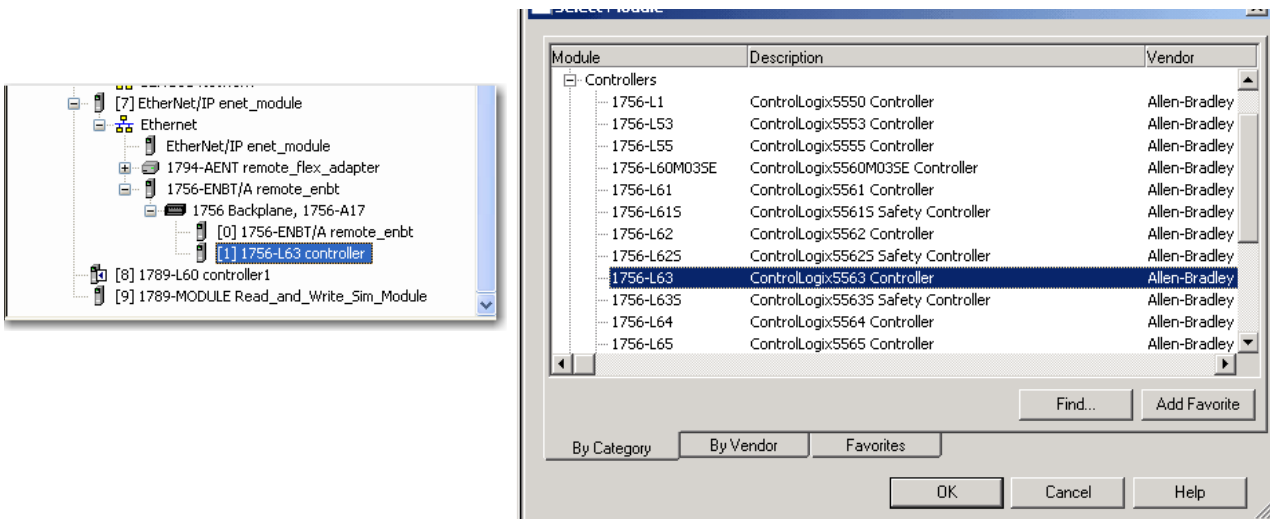

## Add a Consumed Tag

A consumed tag's value comes from a remote controller. The local controller is the consumer, and the remote controller is the producer. Consumed tags are always at controller scope.

Complete these steps to add a consumed tag.

1. On the Controller folder in the Controller Organizer, right-click Controller Tags and choose New tag.



The New Tag dialog box appears.

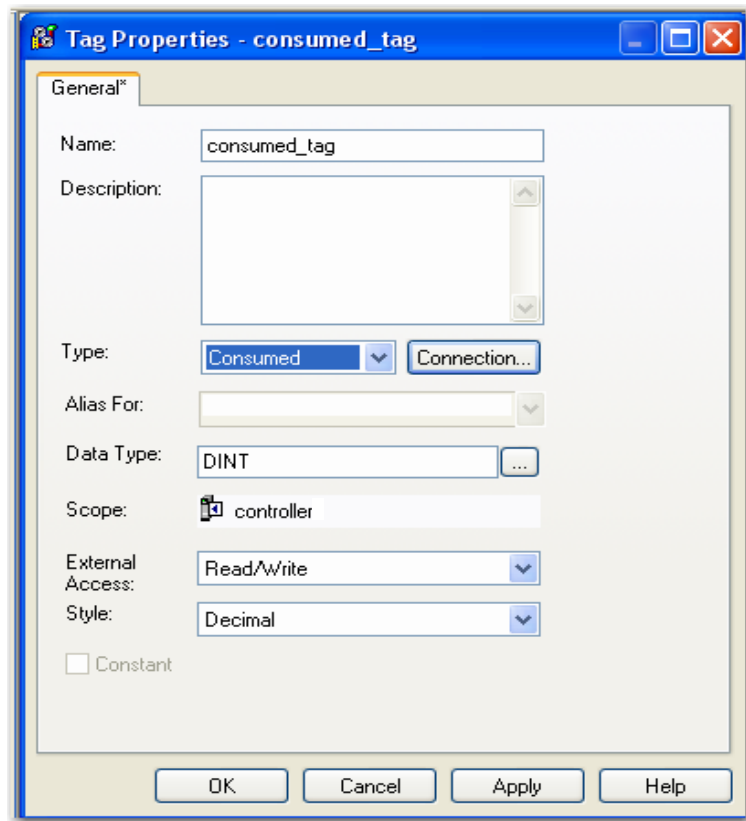

2. Enter tag configuration information.

Parameter	Description
Name	Enter the name of the tag.
Description	Enter a tag description.
Type	Consumed.
Data Type	Enter the type of tag you want to create.
Scope	Consumed tags are always controller scope.
External Access	Select whether the tag has Read/Write, Read Only, or no access (None) from external applications such as HMIs.
Style	Choose the default style in which to display the value of the tag. The pull-down menu lists available display styles for the chosen data type. Choose from Binary, Decimal, Hex, Octal, Date/Time, ASCII, Exponential, or Float.

3. Click Connection.

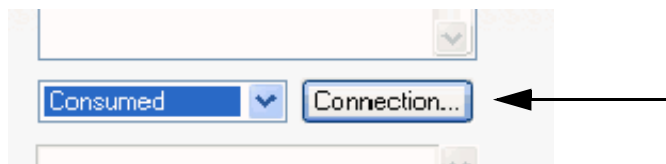

The Consumed Tag Connection dialog box appears.

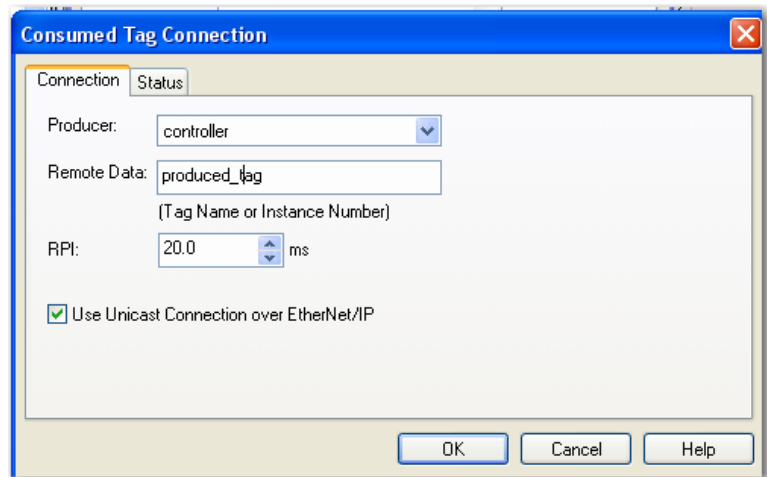

4. Configure connection properties in the Consumed Tag Connection dialog box.

Parameter	Description
Producer	Choose the name of the controller producing the data. The pull-down menu lists only those options that are available.
Remote Data	Enter the name of the tag in the remote controller that you want to consume.
RPI	Enter the requested packet interval. This is the amount of time (in ms) between updates of the data from the remote controller. This is the minimum rate at which the local controller receives data. The valid RPI range for a Standard consumed tag is 0.196...536870.911 ms. The valid RPI range for a Safety consumed tag is 1...500 ms and can only be set on the Safety tab of the Consumed Tag Connection dialog box. Note that the Safety Tag RPI must match the rate specified by Safety Task Period of the producing controller. You must be offline or online in Program mode to change the RPI.

5. Click OK when done.

To view the tag, from the Controller, double click the Controller Tags folder in the Controller Organizer.

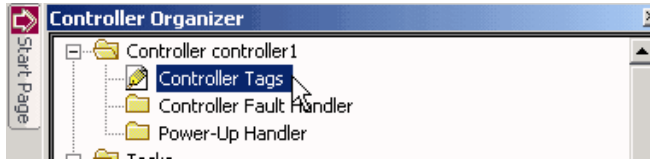

+ remote_flex_adapter:I	{...}	{...}	
+ remote_flex_adapter:O	{...}	{...}	
+ servo_1_axis	{...}	{...}	
+ servo_drive_axis	{...}	{...}	
+ consumed_tag	0		Decimal

## Check EtherNet/IP Statistics

The SoftLogix controller installs with an EtherNet/IP statistics utility that displays different counters for the EtherNet/IP module.

Complete these steps to display the statistics.

1. Choose the EtherNet/IP Statistics Utility from the folder where you installed the SoftLogix controller.

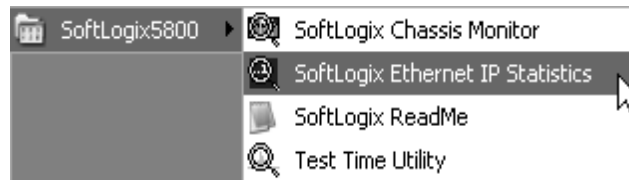

The SoftLogix 5800 EtherNet/IP Module Statistics dialog box appears.

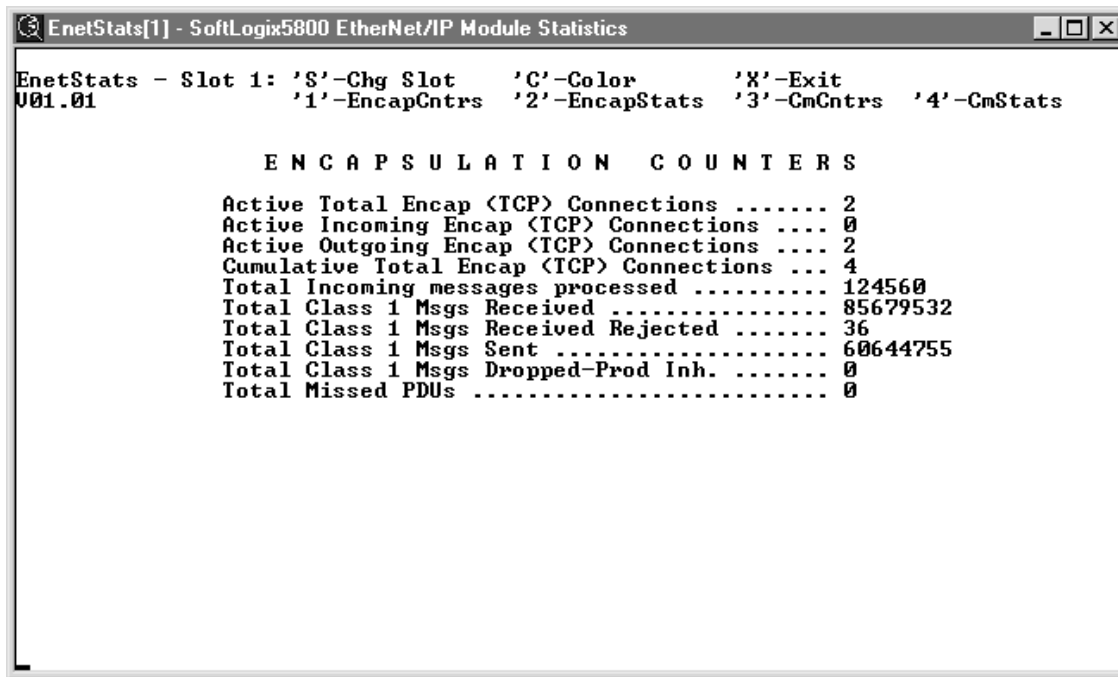

2. Use the character key at the top of the utility screen to display information and change screen characteristics.



### Example 1: Workstation Remotely Connected to a SoftLogix Controller

In this example, a workstation remotely connects to a SoftLogix controller over an Ethernet network to remotely program the SoftLogix controller.

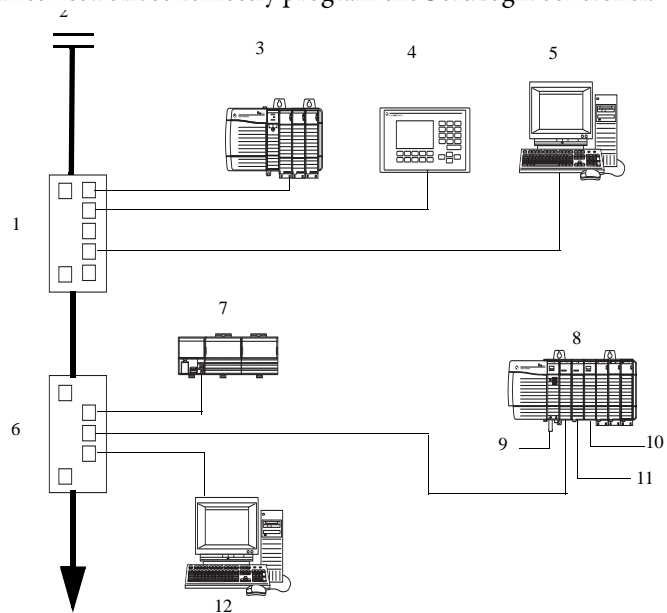

Item	Description
1	Ethernet switch
2	Firewall/router
3	ControlLogix chassis with controller and Ethernet module
4	PanelView terminal
5	Personal computer running RSLinx software and the Logix Designer application
6	Ethernet switch
7	FLEX I/O system with Ethernet adapter
8	ControlLogix gateway
9	To ControlNet network
10	To DeviceNet network
11	To DH+ network
12	SoftLogix 5800 controller

Browsing from a computer to a remote SoftLogix controller looks like this example.

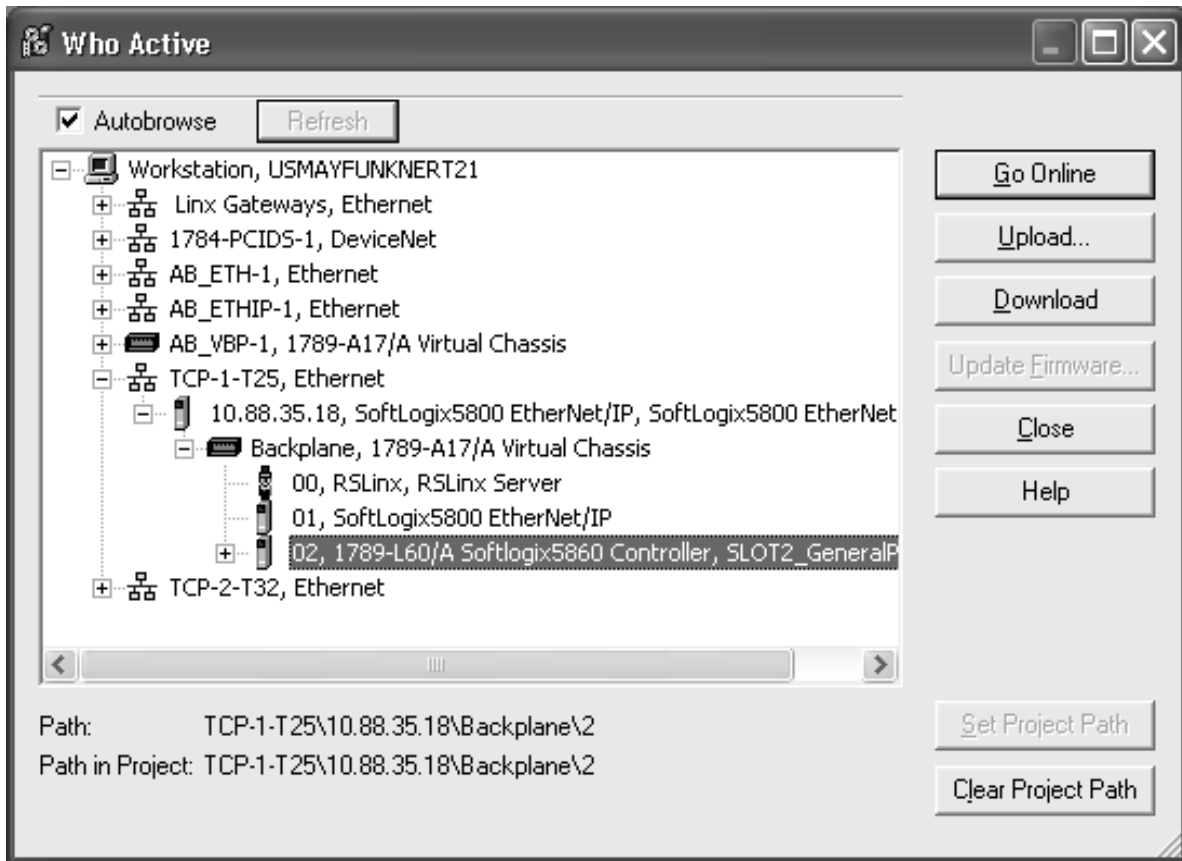

Browsing from the EtherNet/IP module in a SoftLogix controller to remote devices looks like this example.

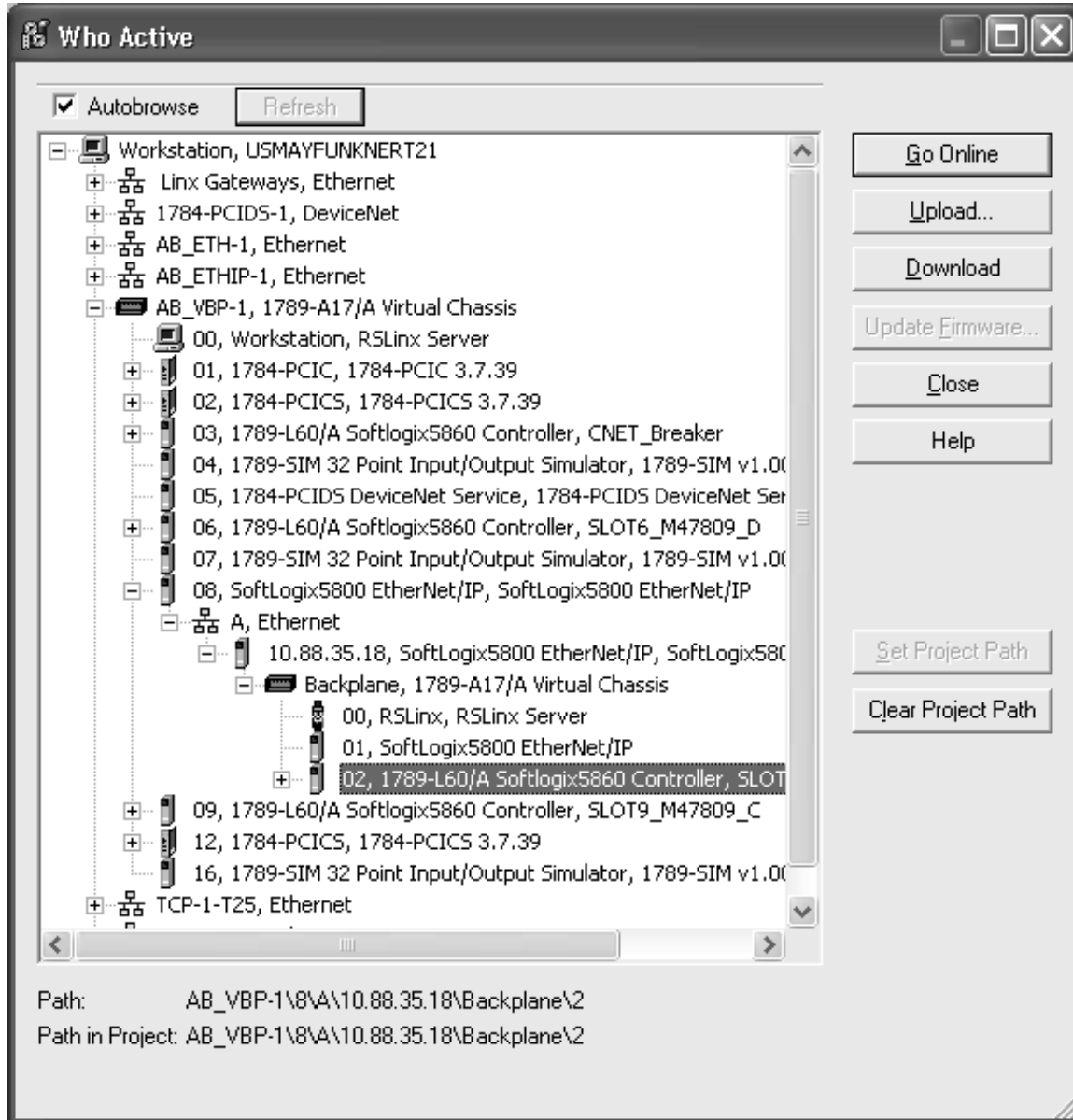

The computer cannot be an RSLinx gateway. The UDP option in RSLinx software must be disabled.

## Example 2: Send Messages over the EtherNet/IP Network

In the following example, the SoftLogix controller can send messages to the other devices on the EtherNet/IP network.

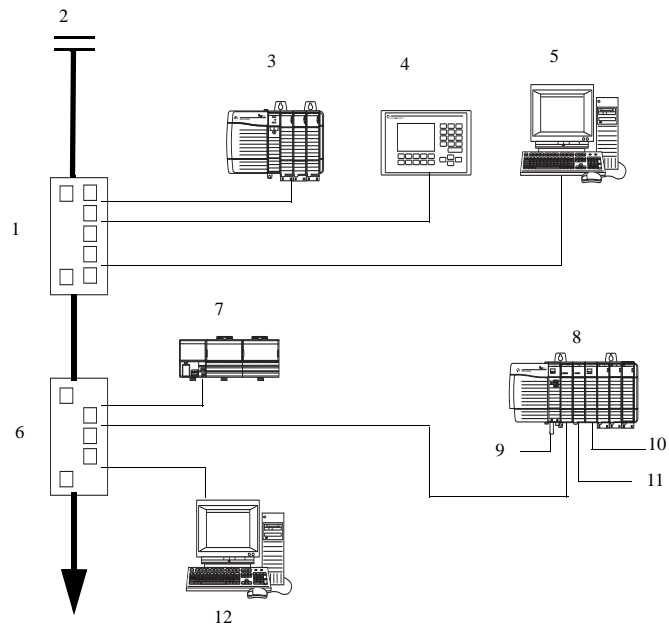

Item	Description
1	Ethernet switch
2	Firewall/router
3	ControlLogix chassis with controller and Ethernet module
4	PanelView terminal
5	Personal computer running RSLinx software and the Logix Designer application
6	Ethernet switch
7	FLEX I/O system with Ethernet adapter
8	ControlLogix gateway
9	To ControlNet network
10	To DeviceNet network
11	To DH+ network
12	SoftLogix 5800 controller

## Configure a MSG Instruction

How you configure the MSG instruction depends on the target device.

1. Click MSG to launch the Message Configuration dialog box.

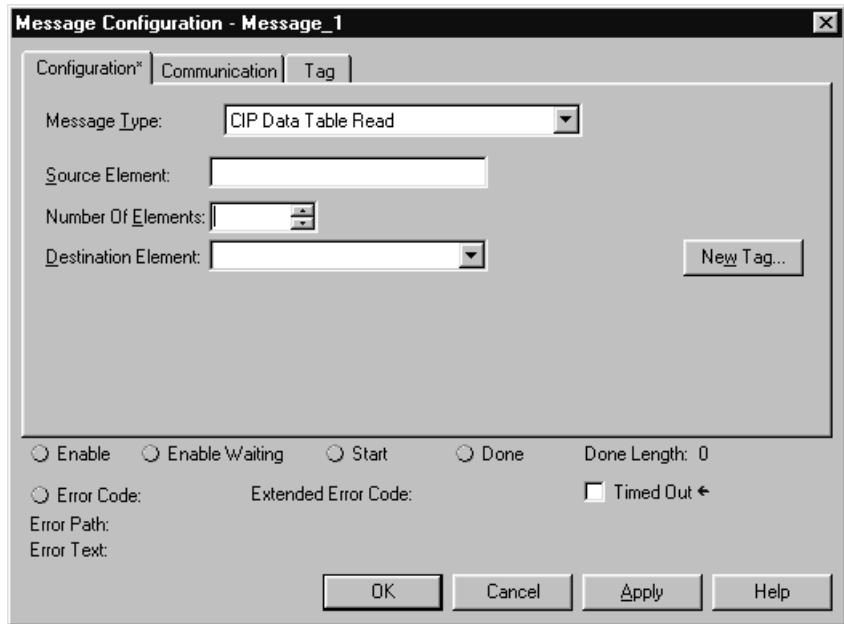
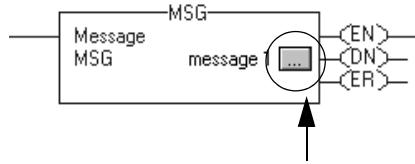

2. On the Configuration tab, configure the following.

For this item	Specify
Message Type	CIP Data Table Read or CIP Data Table Write
Source Element	Tag containing the data to be transferred
Number of Elements	Number of array elements to transfer
Destination Tag	Tag to which the data will be transferred

On the Communication tab, specify the communication path.

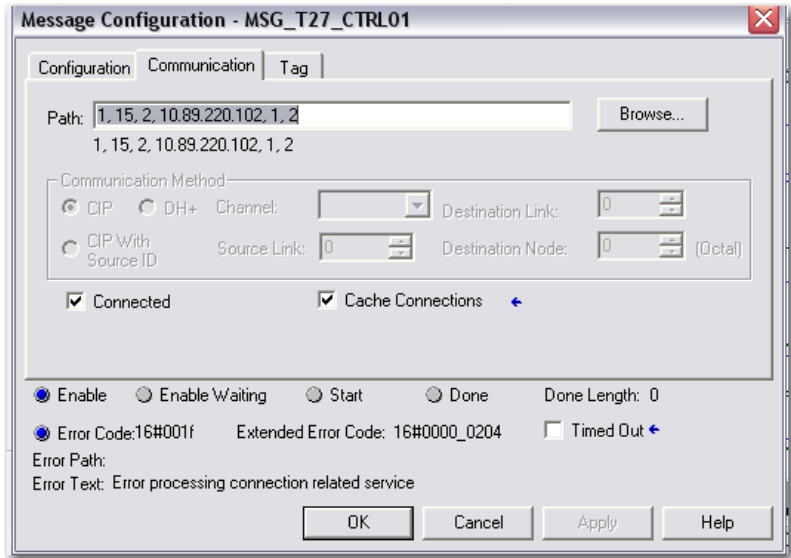

A communication path requires pairs of numbers. The first number in the pair identifies the port from which the message exits. The second number in the pair designates the node address of the next device.

For this item	Specify
Communication Path (Each SoftLogix controller resides in its own computer)	1,2,130.151.255.43,1,5 where: 1 is the SoftLogix backplane of Soft1 2 is Ethernet port in slot 5 130.151.255.43 is IP address of the target 1 is the SoftLogix backplane of Soft2 5 is the controller slot of Soft2
Communication Path (Each SoftLogix controller resides in the same computer)	1,5 where: 1 is the SoftLogix backplane of Soft1 5 is the controller slot of Soft2

### Example 3: Send Messages over the EtherNet/IP Network to a PLC-5 Processor

In this example, the SoftLogix controller sends a message through the 1756-ENBT, out the 1756-DHRIO, and to a PLC-5 processor at DH+ node 2.

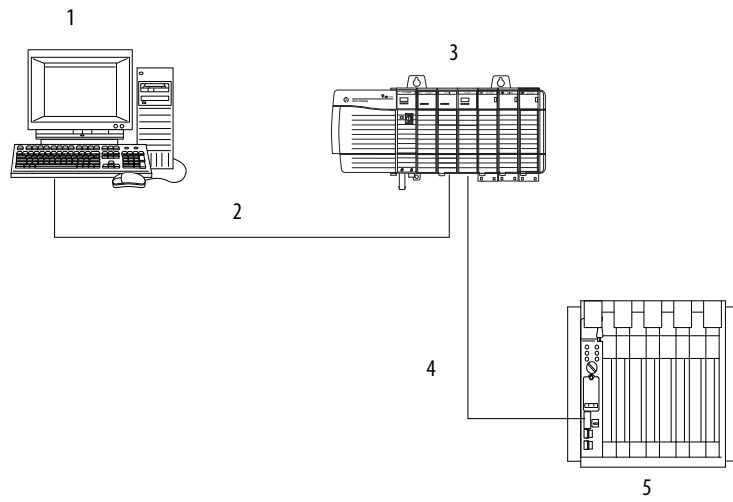

Item	Description
1	SoftLogix 5800 controller
2	Ethernet network
3	ControlLogix controller with 1756-ENBT and 1756-DHRIO modules
4	DH+ network
5	PLC-5 processor

### Configure a MSG Instruction

Use a PLC-5 Typed Write MSG instruction.

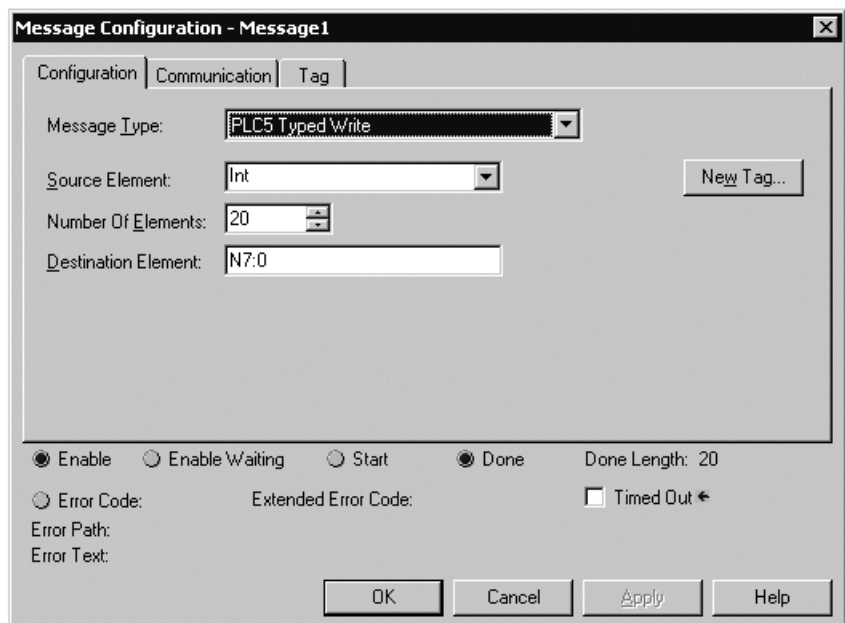

Specify the path and communication method.

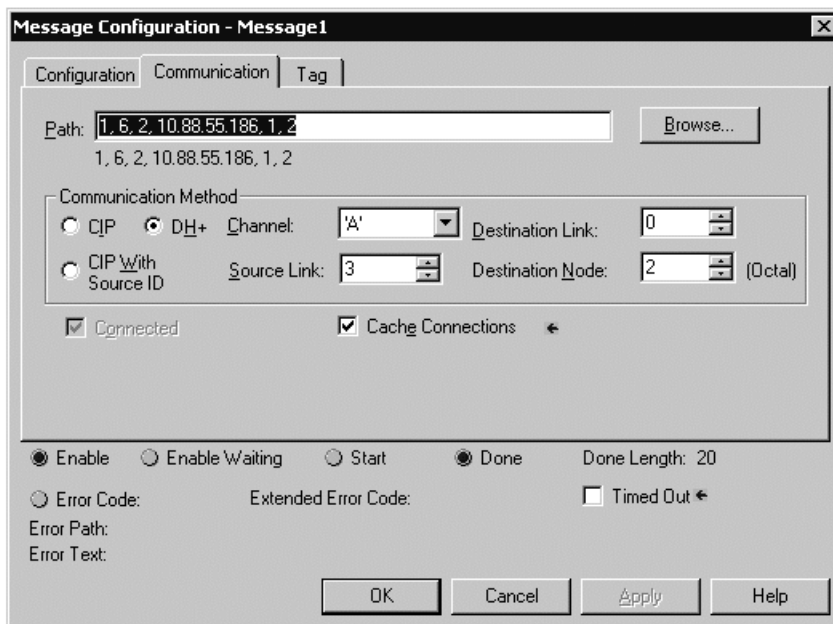

The example path is 1, 6, 2, 10.88.55.186, 1, 2.

This value	Specifies
1	The SoftLogix virtual chassis
6	The sending device (the Ethernet port in the controller's computer) is in slot 6 of the virtual chassis
2	Sending the message out the Ethernet communication port
10.88.55.186	The IP address of the 1756-ENBT module
1	The 1756 backplane
2	The slot where the 1756-DHRIO module is in the 1756 chassis

This is an example communication method.

This field	Specifies
Channel = A	Channel A on the 1756-DHRIO module
Source Link = 3	The DH+ address of the 1756-DHRIO module is node 3
Destination Node = 2	The DH+ address of the PLC-5 processor is node 2



### Example 4: Control Distributed I/O

In this example, one SoftLogix controller controls distributed I/O through a 1794-AENT module.

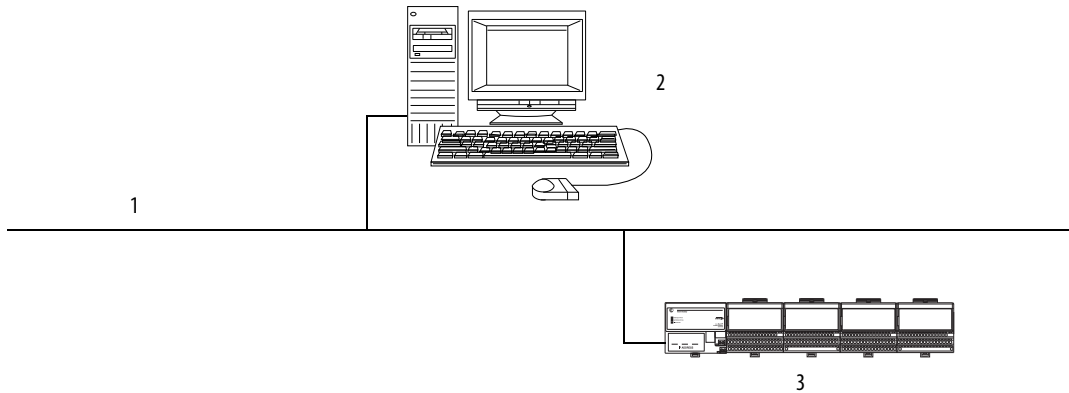

Item	Description
1	EtherNet/IP network
2	SoftLogix controller (Soft1)
3	1794-AENT with distributed I/O (remote_flex_adapter)

This example has Soft1 controlling the I/O connected to the remote 1794-AENT module. The data the SoftLogix controller receives from the distributed I/O modules depends on how you configure the I/O modules. You can configure each module as a direct connection or as rack optimized. One chassis can have a combination of some modules configured as a direct connection and others as rack optimized.

All analog modules require direct connections. Diagnostic modules support rack-optimized connections, but require direct connections to take full advantage of the diagnostic feature.

In the Logix Designer application, the controller project and associated tags looks like this example.

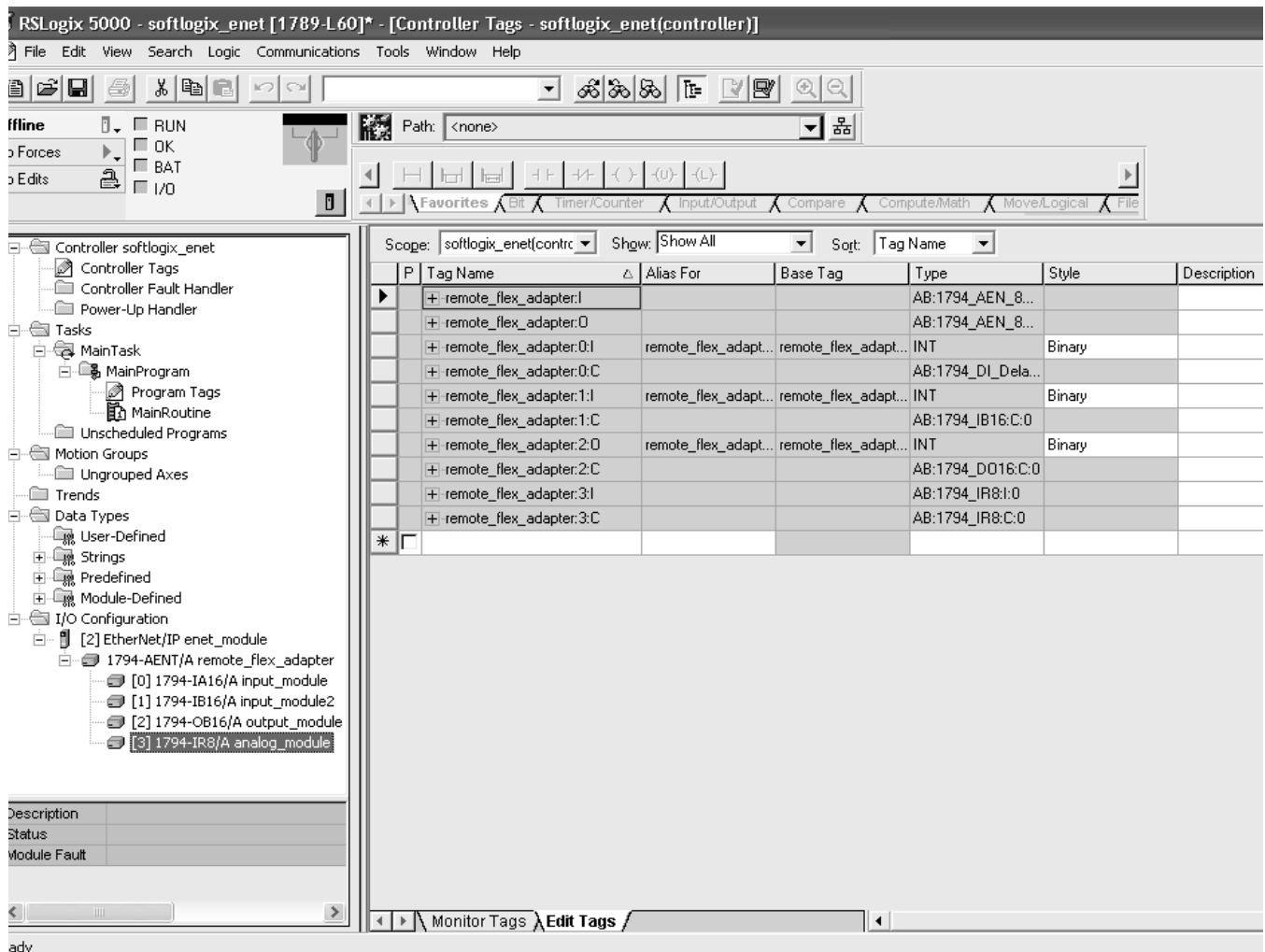

Throughput is based on the performance of the personal computer running the SoftLogix controller.

## Communicate with Serial Devices

Topic	Page
Configure Your System for a Serial Device	75
Controller Status Indicators	85
Example 1: Workstation Directly Connected to a SoftLogix Controller	85
Example 2: Workstation Remotely Connected to a SoftLogix Controller	86
Example 3: SoftLogix Controller to a Bar Code Reader	90

This chapter explains how to use a serial device with your SoftLogix system. Details on configuring your system for a serial device and examples are included.

---

**IMPORTANT** Limit the length of serial (RS-232) cables to 15.2 m (50 ft).

---

### Configure Your System for a Serial Device

For the SoftLogix controller to operate with a serial device, you need the following:

- A computer where the SoftLogix controller resides to have a serial port
- RSLinx software to configure the serial communication driver

If a remote computer communicates with the SoftLogix controller via a serial connection, the remote computer must have the serial driver installed. The computer with the SoftLogix controller does not need the serial driver to connect to other devices over a serial device

- Logix Designer application to configure the serial port of the controller

## Step 1: Configure the Serial Port

Use the SoftLogix Chassis Monitor to choose which COM port to use for serial communication. The controller supports only one COM port for DF1 communication.

Follow these steps to configure serial communication.

1. In the SoftLogix Chassis Monitor, from the Slot menu, choose Create Module.

Or right-click the appropriate slot and choose Create.



The Select Module dialog box appears.

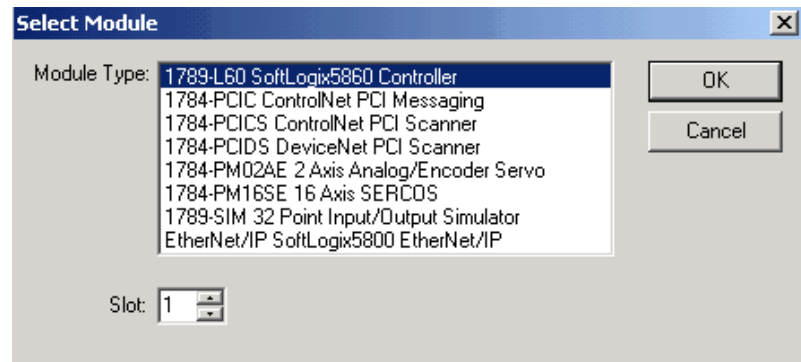

2. In the Select Module dialog box, choose the 1789-L60 SoftLogix5860 Controller.
3. Choose the backplane slot number.

For this example, we will choose Slot 1.

4. Click OK.

The General dialog box appears.

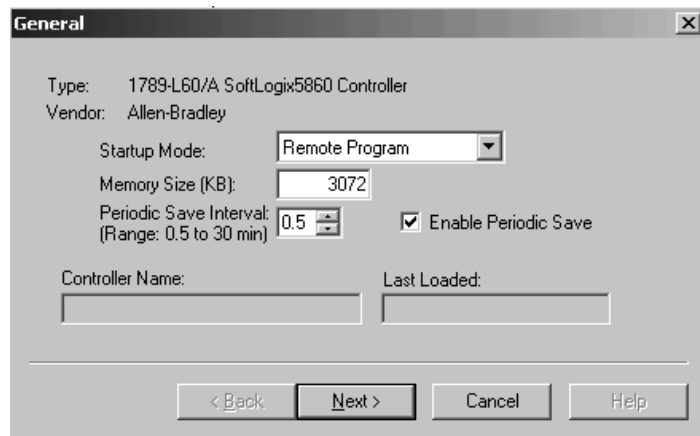

5. Specify the settings for the controller.
6. Click Next.

The NT System dialog box appears.

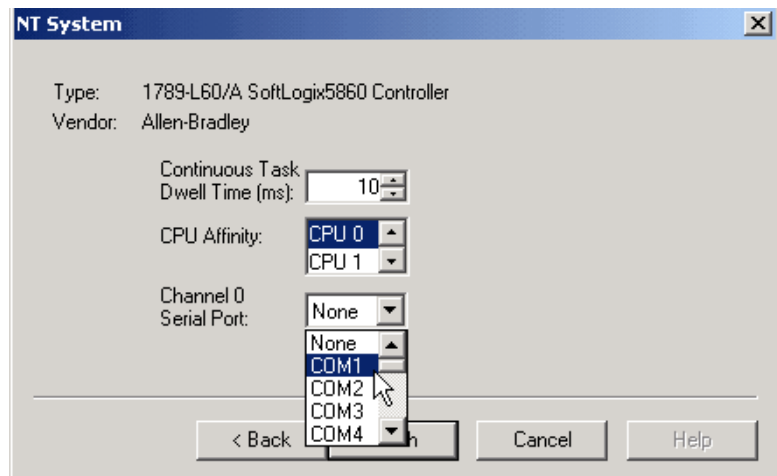

7. Choose the COM port.
8. Click Finish.

Your SoftLogix Chassis Monitor now looks like this example.

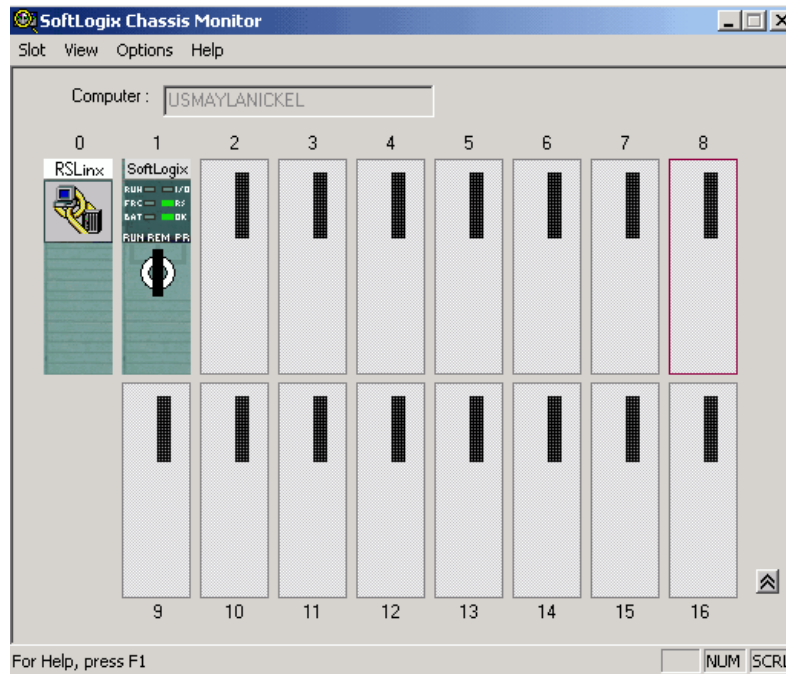

## Change the COM Port Setting

Once you choose a COM port for the controller, you can only change the setting by removing the controller from the chassis and reinstalling the controller.

Follow these steps to change the COM port.

1. In the SoftLogix Chassis Monitor, from the Slot menu, choose Remove Module.

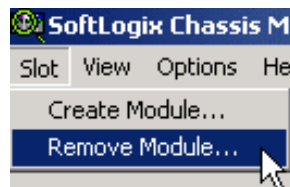

The Remove Module dialog box appears.

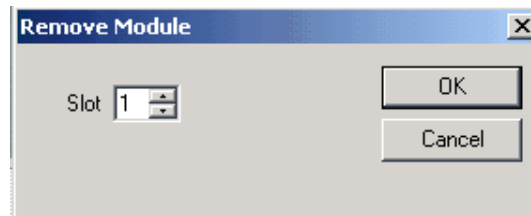

2. Verify the slot number and click OK.

The Remove Module verification dialog box appears.

Do not clear the SoftLogix Chassis Monitor module configuration unless you want to enter all new information.

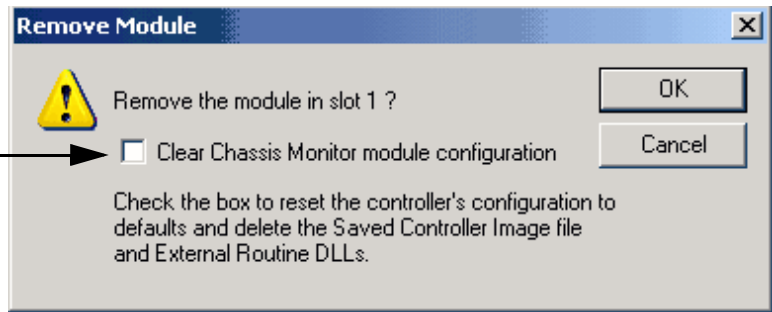
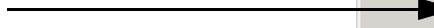

3. Click OK.

The SoftLogix Chassis Monitor now appears with slot 1 empty.

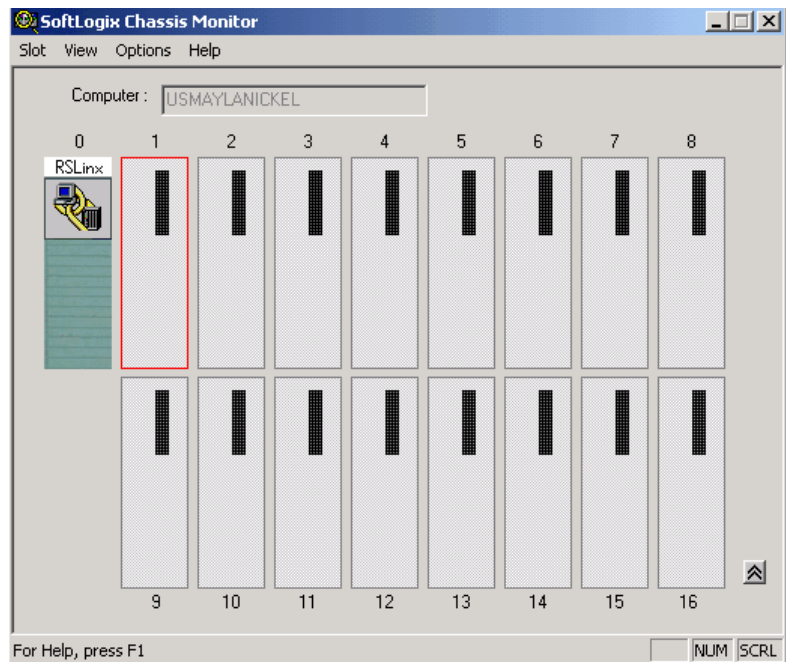

4. In the same slot, re-add the controller.

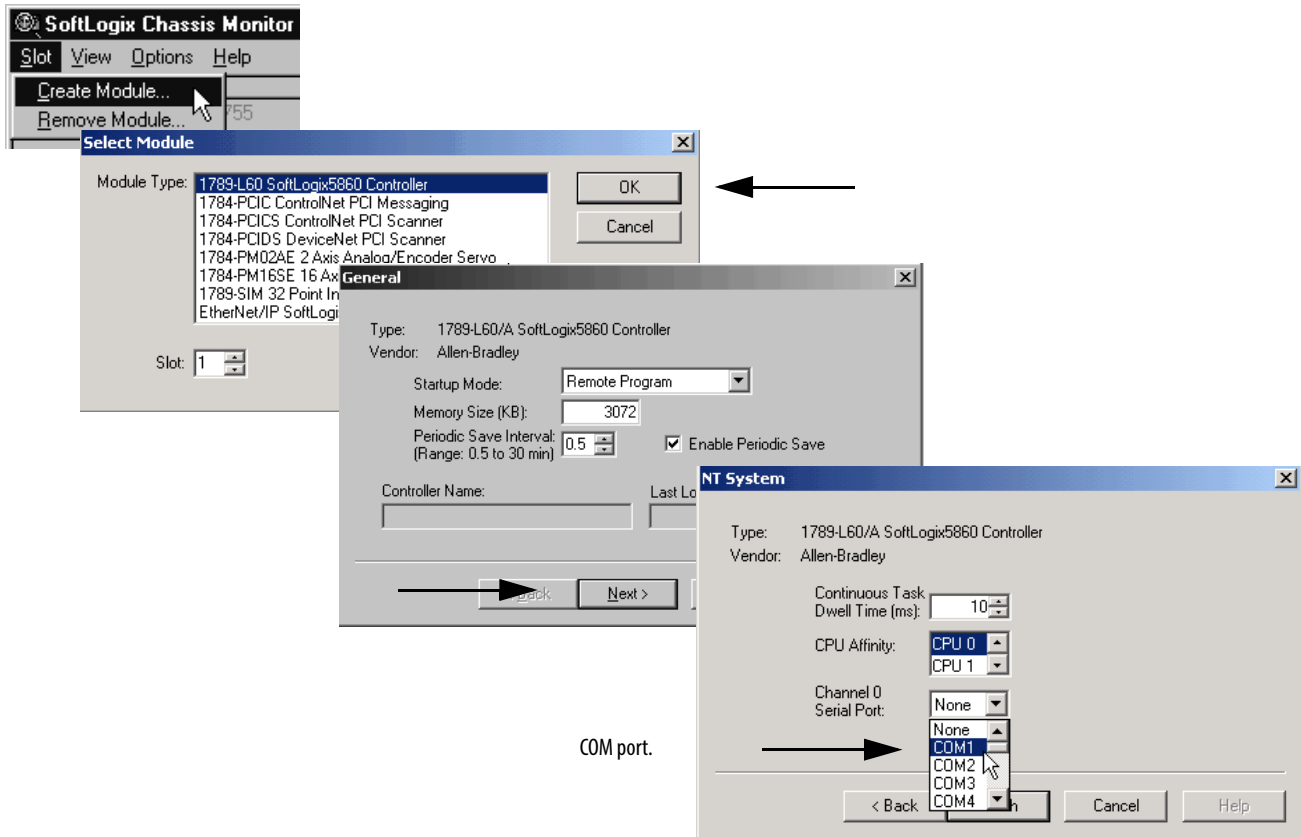

The SoftLogix Chassis Monitor prompts whether to use the previous configuration.

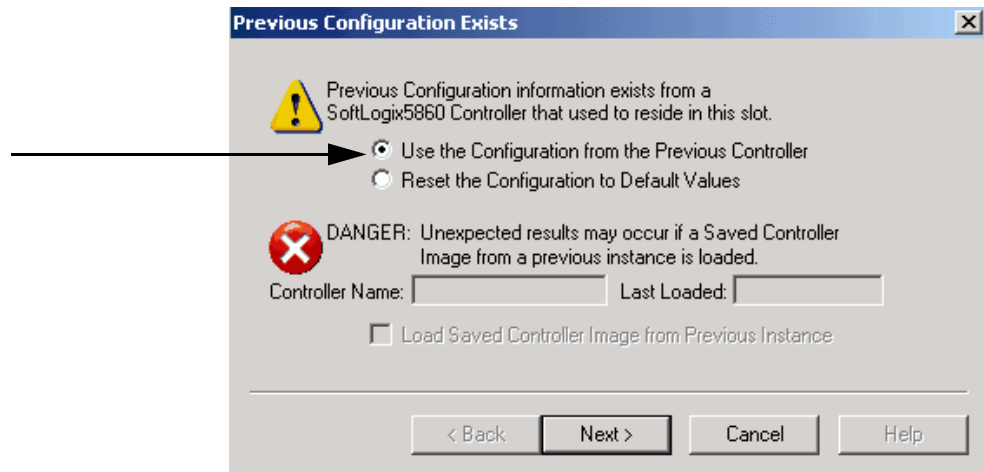

5. Click Next.



Your SoftLogix Chassis Monitor looks like this example.

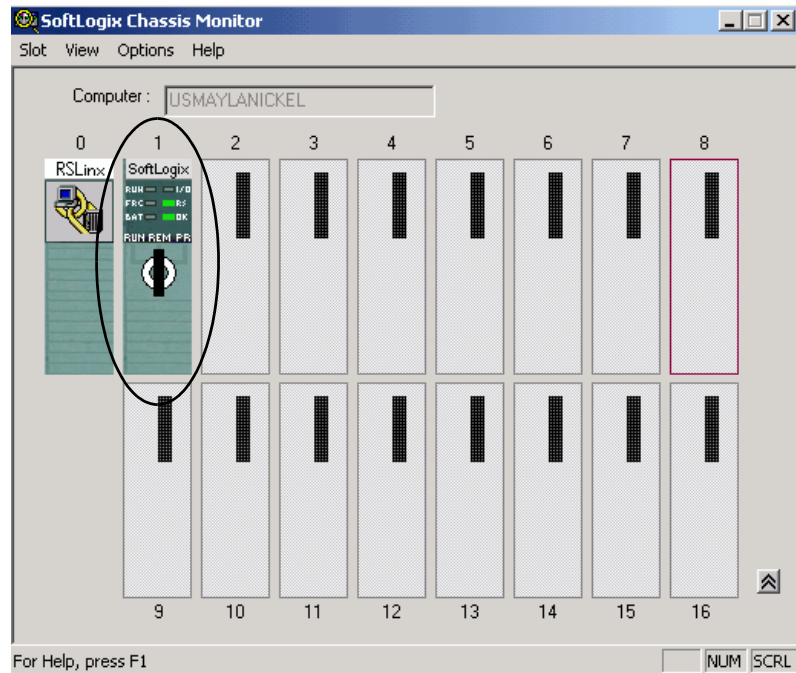

## Step 2: Configure the Serial Port of the Controller in the Project

Complete these steps to configure the controller in your project.

1. Open a project in the Logix Designer application and add the controller to the I/O Configuration folder.

[Refer to Step 3: Configure the Controller in the Logix Designer Application Project on page 32.](#)

2. From the Edit menu, choose Controller Properties.

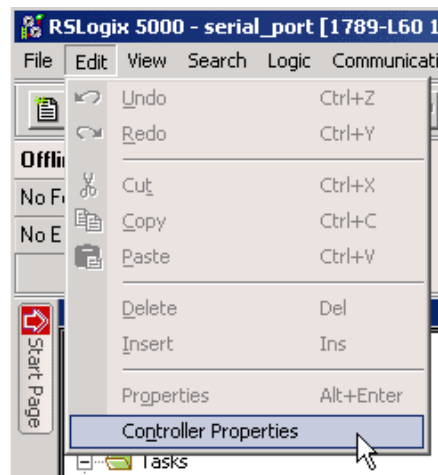

The Controller Properties dialog box appears.

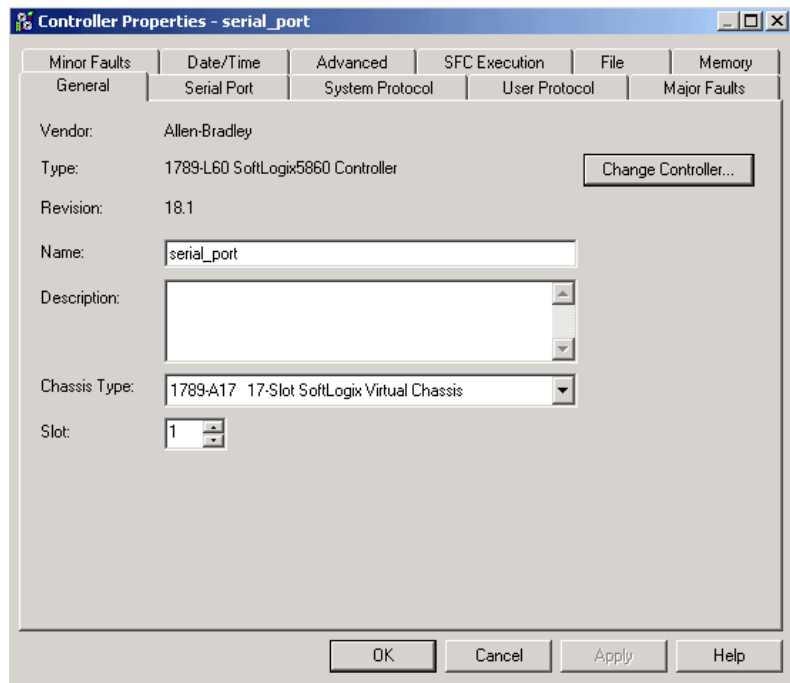

3. On the Serial Port tab, specify the appropriate serial port settings.

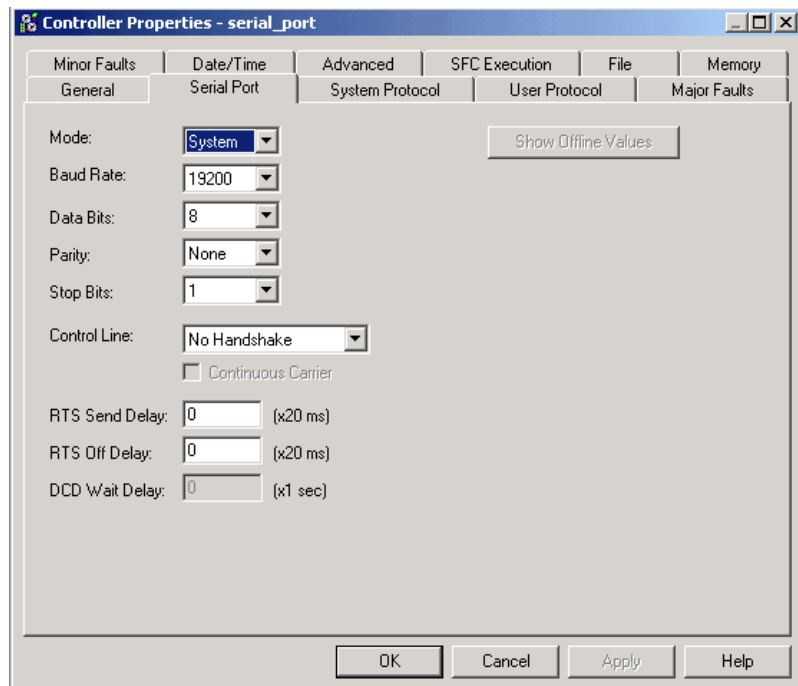

*Specify Serial Port Characteristics*

Specify these characteristics on the Serial Port tab.

<b>Characteristic</b>	<b>Description</b>
Mode	Choose System (for DF1 communication) or User mode (for ASCII communication).
Baud Rate	Specifies the communication rate for the serial port. Choose a baud rate that all devices in your system support. Select 110, 300 600, 1200, 2400, 4800, 9600, or 19200 Kbps.
Data Bits	Specifies the number of bits per message packet. Choose 8. (7 is ASCII only.)
Parity	Specifies the parity setting for the serial port. Parity provides additional message-packet error detection. Parity is an additional non-data bit attached to a binary word. Its purpose is to provide a check of the data integrity by making the sum of the number of ones in a word always even or odd. Choose None or Even.
Stop bits	Specifies the number of stop bits to the device with which the controller is communicating. Choose 1. (2 is ASCII only.)
Control line	Specifies the mode in which the serial driver operates. Choose No Handshake, Full-Duplex, Half-Duplex with Continuous Carrier, or Half-Duplex without Continuous Carrier. If you are not using a modem, choose No Handshake. If both modems in a point-to-point link are full-duplex, choose Full-Duplex for both controllers. If the master modem is full duplex and the slave modem is half-duplex, choose Full-Duplex for the master controller and choose Half-Duplex with Continuous Carrier for the slave controller. If all the modems in the system are half-duplex, choose Half-Duplex without Continuous Carrier for the controller.
RTS Send Delay	Enter a count that represents the number of 20 ms periods of time that elapse between the assertion of the RTS signal and the beginning of a message transmission. This time delay lets the modem prepare to transmit a message. The CTS signal must be high for the transmission to occur. The range is 0...32767 periods.
RTS Off Delay	Enter a count that represents the number of 20 ms periods of time that elapse between the end of a message transmission and the de-assertion of the RTS signal. This time delay is a buffer to make sure the modem successfully transmits the entire message. The range is 0...32767 periods. Normally leave at zero.
DCD Wait Delay	Applies to the DF1 Radio Modem protocol only.

- Click the System Protocol tab and specify the appropriate settings.

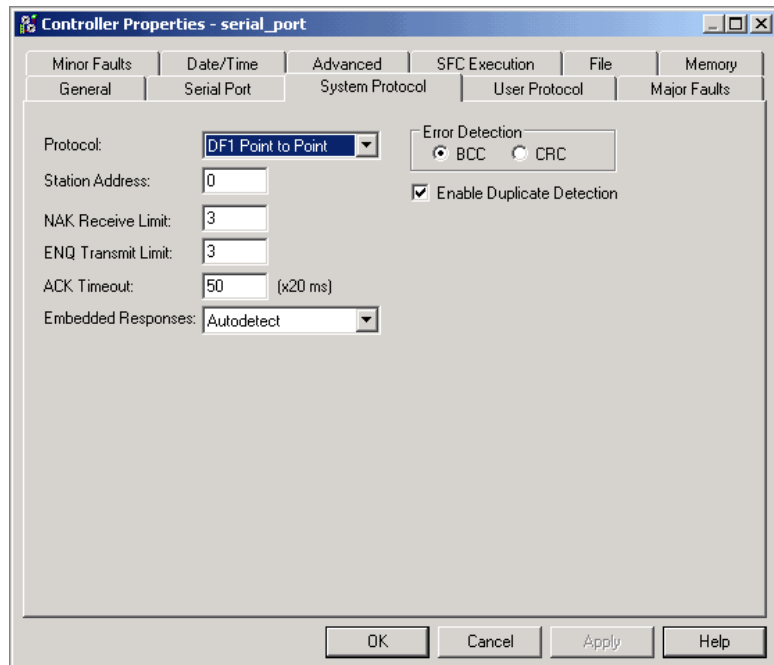

### Specify System Protocol Characteristics

These are the available system modes and their characteristics.

**Table 4 - System Protocol Tab Descriptions**

Field	Mode
Protocol	<p>DF1 Master - control of polling and message transmission between the master and slave nodes. The master/slave network includes one controller configured as the master node and as many as 254 slave nodes. Link slave nodes by using modems or line drivers. A master/slave network can have node numbers from 0 . . . 254. Each node must have a unique node address. Also, at least 2 nodes must exist to define your link as a network (1 master and 1 slave station are the two nodes). See <a href="#">page 88</a>.</p>
	<p>DF1 Point-to-Point - communication between the controller and one other DF1-protocol-compatible device. This is the default system mode. This mode is typically used to program the controller through its serial port. See <a href="#">page 86</a>.</p>
	<p>DF1 Radio Modem - Check the Enable Store and Forward check box if you want to enable the store and forward functionality. When enabled, the destination address of any received message is compared to the Store and Forward tag table. If there is a match, the message is then forwarded (re-broadcasted) out the port. From the Store and Forward Tag pull-down menu, choose an integer (INT[16]) tag. Each bit represents a station address. If this controller reads a message destined for a station that has its bit set in this table, it forwards the message. Click OK to accept your edits and close the Controller Properties dialog box.</p>
	<p>DF1 Slave - by using a controller as a slave station in a master/slave serial communication network. When there are multiple slave stations on the network, link slave stations by using modems or line drivers. When you have a single slave station on the network, you do not need a modem to connect the slave station to the master; you can configure the control parameters for no handshaking. You can connect 2-255 nodes to a single link. In DF1 Slave mode, a controller uses DF1 half-duplex protocol. One node is designated as the master and it controls who has access to the link. All the other nodes are slave stations and must wait for permission from the master before transmitting. See <a href="#">page 90</a>.</p>

**Table 4 - System Protocol Tab Descriptions**

Field	Mode
Station Address	The station address for the serial port on the DF1 point-to-point network. Enter a valid DF1 address (0 . . .254). Address 255 is reserved for broadcast messages. The default is 0.
Enable Store and Forward	Enable Store Forward box should only be checked if the controller that you are downloading the project to is connected to the Master radio modem. This particular controller will help support the radio modem network that is being created.
Error Detection	In the Error Detection section, click one of the radio buttons to specify the error detection scheme used for all messages. BCC: the processor sends and accepts messages that end with a BCC byte. BCC is quicker and easier to implement in a computer driver. This is the default. CRC: the processor sends and accepts messages with a 2-byte CRC. CRC is a more complete method.

## Controller Status Indicators

The SoftLogix controller has an RS-232 status indicator that follows this behavior.

Indicator	Description
Off	You selected 'None' for the COM port selection of the controller.
Green	The COM port you selected was successfully assigned to channel 0 of the controller.
Red	There is conflict with COM port or the COM port number you selected is invalid.

Please note that these status indicator states are different than for the ControlLogix controller.

## Example 1: Workstation Directly Connected to a SoftLogix Controller

In this example, a workstation directly connects to a SoftLogix controller over a serial device.



Item	Description
1	Serial
2	Workstation with Logix Designer application
3	Computer with SoftLogix controller

Use the Logix Designer application to configure the controller’s serial port for the DF1 Point-to-Point (full-duplex) protocol. This type of protocol supports simultaneous transmission between two devices in both directions. The DF1 Point-to-Point protocol controls message flow, detects and signals errors, and retries if errors are detected.

**IMPORTANT** The workstation with the Logix Designer application must also have the Logix5550® serial port driver installed through RSLinx software.

### DF1 Point-to-Point Configuration

Field	Description
Station Address	The station address for the serial port on the DF1 point-to-point network. Enter a valid DF1 address (0...254). Address 255 is reserved for broadcast messages. The default is 0.
NAK Receive Limit	Specifies the number of NAKs the controller can receive in response to a message transmission. Enter a value 0...127. The default is 3.
ENQ Transmit Limit	Specifies the number of inquiries (ENQs) you want the controller to send after an ACK timeout. Enter a value 0...127. The default is 3.
ACK Timeout	Specifies the amount of time you want the controller to wait for an acknowledgment to its message transmission. Enter a value 0...32767. Limits are defined in 20 ms intervals. The default is 50 (1000 ms).
Embedded Response	Specifies how to enable embedded responses. Choose Autodetect (enabled only after receiving one embedded response) or Enabled. The default is Autodetect.
Error Detection	Choose BCC or CRC error detection. Configure both stations to use the same type of error checking. BCC: the controller sends and accepts messages that end with a BCC byte for error checking. BCC is quicker and easier to implement in a computer driver. This is the default. CRC: the controller sends and accepts messages with a 2-byte CRC for error checking. CRC is a more complete method.
Enable Duplicate Detection	Choose whether the controller should detect duplicate messages. The default is duplicate detection enabled.

### Example 2: Workstation Remotely Connected to a SoftLogix Controller

In this example, a workstation remotely connects to a SoftLogix controller over a serial device. A modem is connected to the controller to provide remote access.

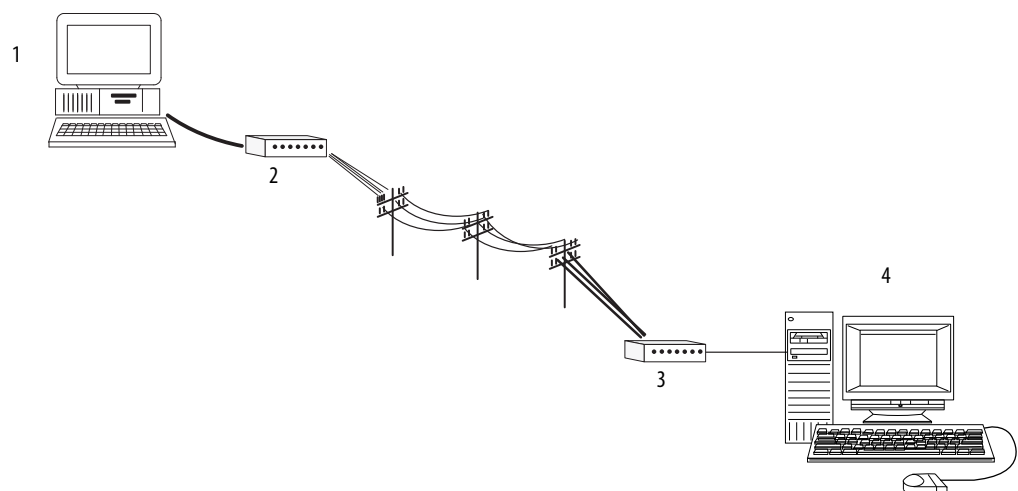

Item	Description
1	Workstation with Logix Designer application and Logix5550 serial port driver
2	Modem
3	Modem
4	SoftLogix controller

If you use a modem to remotely connect the controller to one workstation, use the Logix Designer application to configure the serial port of the controller for the DF1 Point-to-Point (full-duplex) protocol, as in the previous example. If the controller is part of a master/slave serial device, configure the serial port of the controller for either the DF1 master or DF1 Slave protocol (both half-duplex).

### Master and Slave Communication Methods

A master station can communicate with a slave station in these two ways.

Name	Method	Benefits
Standard Communication mode	Initiates polling packets to slave stations according to their position in the polling array. Polling packets are formed based on the contents of the normal poll array and the priority poll array.	This communication method is most often used for point-to-multipoint configurations. This method provides these capabilities: <ul style="list-style-type: none"> <li>• Slave stations can send messages to the master station (polled report-by-exception).</li> <li>• Slave stations can send messages to each other via the master.</li> <li>• Master maintains an active station array.</li> <li>• The poll array resides in a user-designated data file. You can configure the master.</li> </ul> To send messages during its turn in the poll array or for between-station polls (master transmits any message that it needs to send before polling the next slave station). In either case, configure the master to receive multiple messages or a single message per scan from each slave station.
Message-based Communication mode	Initiates communication to slave stations by using only user-programmed message (MSG) instructions. Each request for data from a slave station must be programmed via a MSG instruction. The master polls the slave station for a reply to the message after waiting a user-configured period of time. The waiting period gives the slave station time to formulate a reply and prepare the reply for transmission. After all of the messages in the master's message-out queue are transmitted, the slave-to-slave queue is checked for messages to send.	If your application uses satellite transmission or public switched-telephone-network transmission, consider choosing message-based communication. Communication to a slave station can be initiated on an as-needed basis. Also choose this method if you need to communicate with non-intelligent remote terminal units (RTUs).

## DF1 Slave Configuration

Field	Description
Station Address	The station address for the serial port on the DF1 slave. Enter a valid DF1 address (0 . . . 254). Address 255 is reserved for broadcast messages. The default is 0.
Transmit Retries	The number of times the remote station retries a message after the first attempt before the station declares the message undeliverable. Enter a value 0 . . . 127. The default is 3.
Slave Poll Timeout	Specifies the amount of time the slave station waits to be polled by a master before indicating a fault. Enter a value 0 . . . 32767. Limits are defined in 20 ms intervals. The default is 3000 (60,000 ms).
EOT Suppression	Choose whether to suppress sending EOT packets in response to a poll. The default is not to suppress sending EOT packets.
Error Detection	Choose BCC or CRC error detection. Configure both stations to use the same type of error checking. BCC: the controller sends and accepts messages that end with a BCC byte for error checking. BCC is quicker and easier to implement in a computer driver. This is the default. CRC: the controller sends and accepts messages with a 2-byte CRC for error checking. CRC is a more complete method.
Enable Duplicate Detection	Choose whether the controller should detect duplicate messages. The default is duplicate detection enabled.

## DF1 Master Configuration

**Table 5 - Master Station Configuration**

Field	Description
Station Address	The station address for the serial port on the DF1 master. Enter a valid DF1 address (0 . . . 254). Address 255 is reserved for broadcast messages. The default is 0.
Transmit Retries	Specifies the number of times a message is retried after the first attempt before being declared undeliverable. Enter a value 0 . . . 127. The default is 3.
ACK Timeout	Specifies the amount of time you want the controller to wait for an acknowledgment to its message transmission. Enter a value 0 . . . 32767. Limits are defined in 20 ms intervals. The default is 50 (1000 ms).
Reply Message Wait	Message-based Polling mode only Specifies the amount of time the master station waits after receiving an ACK to a master-initiated message before polling the slave station for a reply. Enter a value 0 . . . 65535. Limits are defined in 20 ms intervals. The default is 5 (100 ms).
Polling Mode	Choose one of these: <ul style="list-style-type: none"> <li>• Message-based (slave cannot initiate messages)</li> <li>• Message-based (slave can initiate messages) - default</li> <li>• Standard (multiple message transfer per node scan)</li> <li>• Standard (single message transfer per node scan)</li> </ul>
Master Transmit	<b>Standard Polling modes only</b> Choose when the master station sends messages: <ul style="list-style-type: none"> <li>• Between station polls (default)</li> <li>• In polling sequence</li> </ul>
Normal Poll Node Tag	<b>Standard Polling modes only</b> An integer tag array that contains the station addresses of the slave stations. Create a single-dimension array of data type INT that is large enough to hold all the normal station addresses. The minimum size is three elements. This tag must be controller-scoped. The format is: <i>list[0]</i> contains total number of stations to poll <i>list[1]</i> contains address of station currently being polled <i>list[2]</i> contains address of first slave station to poll <i>list[3]</i> contains address of second slave station to poll <i>list[n]</i> contains address of last slave station to poll



**Table 5 - Master Station Configuration**

Field	Description
Normal Poll Group Size	<b>Standard Polling modes only</b> The number of stations the master station polls after polling all the stations in the priority poll array. Enter 0 (default) to poll the entire array.
Priority Poll Node Tag	<b>Standard Polling modes only</b> An integer tag array that contains the station addresses of the slave stations you need to poll more frequently. Create a single-dimension array of data type INT that is large enough to hold all the priority station addresses. The minimum size is three elements. This tag must be controller-scoped. The format is: <i>list[0]</i> contains total number of stations to be polled <i>list[1]</i> contains address of station currently being polled <i>list[2]</i> contains address of first slave station to poll <i>list[3]</i> contains address of second slave station to poll <i>list[n]</i> contains address of last slave station to poll
Active Station Tag	<b>Standard Polling modes only</b> An array that stores a flag for each of the active stations on the DF1 network. Both the normal poll array and the priority poll array can have active and inactive stations. A station becomes inactive when it does not respond to the master's poll. Create a single-dimension array of data type SINT that has 32 elements (256 bits). This tag must be controller-scoped.
Error Detection	Choose BCC or CRC error detection. Configure both stations to use the same type of error checking. BCC: the controller sends and accepts messages that end with a BCC byte for error checking. BCC is quicker and easier to implement in a computer driver. This is the default. CRC: the controller sends and accepts messages with a 2-byte CRC for error checking. CRC is a more complete method.
Enable Duplicate Detection	Choose whether the controller should detect duplicate messages. The default is duplicate detection enabled.

### *Standard Polling Modes*

The master station polls the slave stations in this order.

1. All stations that are active in the priority poll array
2. One station that is inactive in the priority poll array
3. The specified number (normal poll group size) of active stations in the normal poll array
4. One inactive station, after all the active stations in the normal poll array have been polled

Use the programming software to change the display style of the active station array to binary so you can view which stations are active.

### Example 3: SoftLogix Controller to a Bar Code Reader

In the following example, the SoftLogix controller connects to a bar code reader. A bar code reader is an ASCII device, so you configure the serial port differently than in the previous examples. Configure the serial port for user mode, rather than a DF1 mode.

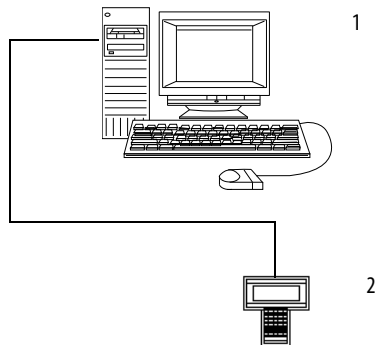

Item	Description
1	SoftLogix controller
2	Barcode reader

### Connect the ASCII Device to the Controller

Do these steps to connect the ASCII device to the serial port of the controller.

1. For the serial port of the ASCII device, determine which pins send signals and which pins receive signals.

2. Connect the sending pins to the corresponding receiving pins and attach jumpers.

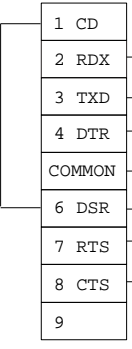
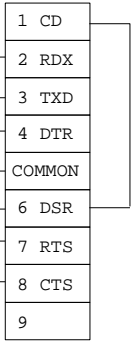
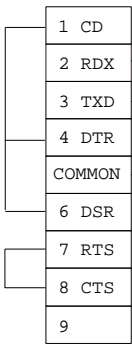
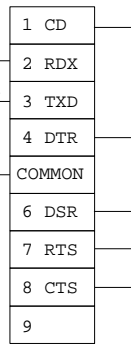
If the communication is	Then wire the connectors as follows
Handshake	<div style="display: flex; justify-content: space-around;"> <div style="text-align: center;"> <p>ASCII Device</p>  </div> <div style="text-align: center;"> <p>Controller</p>  </div> </div> <p style="text-align: right;">42231</p>
Do not handshake	<div style="display: flex; justify-content: space-around;"> <div style="text-align: center;"> <p>ASCII Device</p>  </div> <div style="text-align: center;"> <p>Controller</p>  </div> </div> <p style="text-align: right;">42232</p>

3. Attach the cable shield to both connectors and tie the cable to both connectors.
4. Connect the cable to the controller and the ASCII device.

### User Mode Configuration

Complete these steps to specify ASCII protocol settings.

1. From the Edit menu, choose Controller Properties.

The Controller Properties dialog box appears

2. Click the User Protocol tab.

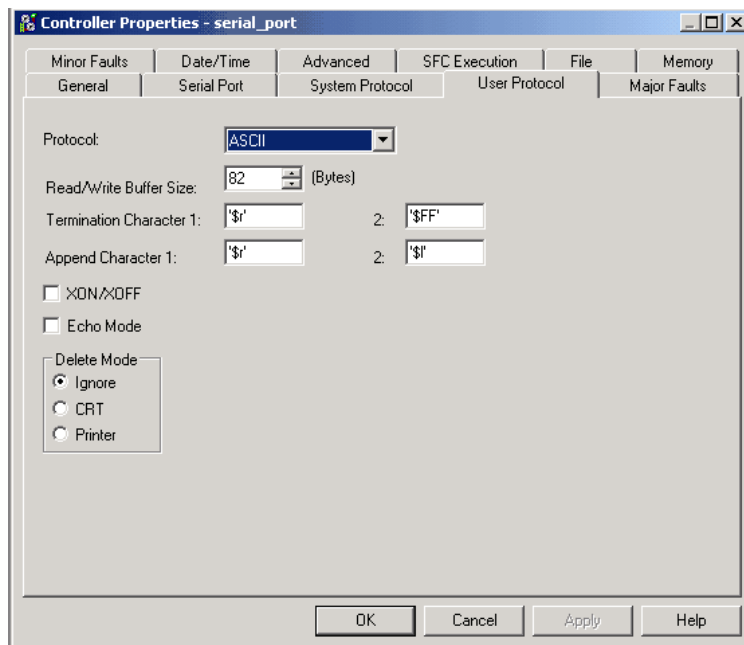

**Table 6 - Default Serial Port Configuration Settings**

Field	Description
Read/Write Buffer Size	Specify the maximum size (in bytes) of the data array you plan to send and receive. The default is 82 bytes.
Termination Character 1 & 2	In the Termination Character 1 and Termination Character 2 fields, enter the character you wish to use to designate the end of a line.
Append Character 1 & 2	In the Append Character 1 and Append Character 2 fields, enter the character you wish to append to the end of a line.
XON/XOFF	Choose whether to regulate the flow of incoming data. The default is disabled.
Echo Mode	Choose whether to echo data back to the device from which it was sent. The default is disabled.
Delete Mode	Choose Ignore, CTR, or Printer for the Delete mode. The default is Ignore.

## ASCII Instructions

The controller supports ASCII instructions to communicate with ASCII devices. Your Logix Designer application CDROM includes programming examples by using ASCII instructions.

For information about using these examples, see the Logix5000 Controllers Common Procedures Programming Manual, publication [1756-PM001](#).

## Configure and Use Simulated I/O

Topic	Page
Configure Your System for a 1789-SIM Module	93
Map I/O Data to the 1789-SIM Module	100
Toggle Inputs and Monitor Outputs	101
Example: Move Application Data into the 1789-SIM Tags	103

This chapter explains how to use SIM modules with a SoftLogix controller.

The 1789-SIM module is a software-only module that comes with the SoftLogix controller; no hardware is required. You can put as many SIM modules as you have available slots, on your system, according to your activation level.

The 1789-SIM module lets you change inputs and monitor outputs of your application by toggling input bits and monitoring output bits on the 1789-SIM module. You use this module to test logic without having physical I/O attached to the system.

### Configure Your System for a 1789-SIM Module

For the SoftLogix controller to simulate local I/O, you need the following:

- A 1789-SIM module (comes with the SoftLogix 5800 controller)
- Logix Designer application to configure the 1789-SIM module

You are limited by the activation level of your SoftLogix controller as to how many modules you can install.

Even though the 1789-SIM module is a software-based module, each module you create uses communication resources. If you are controlling actual I/O and simulating I/O, the 1789-SIM module in your application use communication resources that could impact control performance. If this occurs, increase the RPI of your 1789-SIM module. This maintains control performance because the greater RPI of the 1789-SIM module lessens the load on the SoftLogix system.

## Step 1: Create the 1789-SIM Module in the SoftLogix Chassis Monitor

Before you can operate the module, you must create the 1789-SIM module as part of the SoftLogix Chassis Monitor. You can install as many 1789-SIM modules as allowed by your activation level of the controller.

Complete these steps to install the SIM module.

1. From the Slot menu in the SoftLogix Chassis Monitor, choose Create Module.



The Select Module dialog box appears.

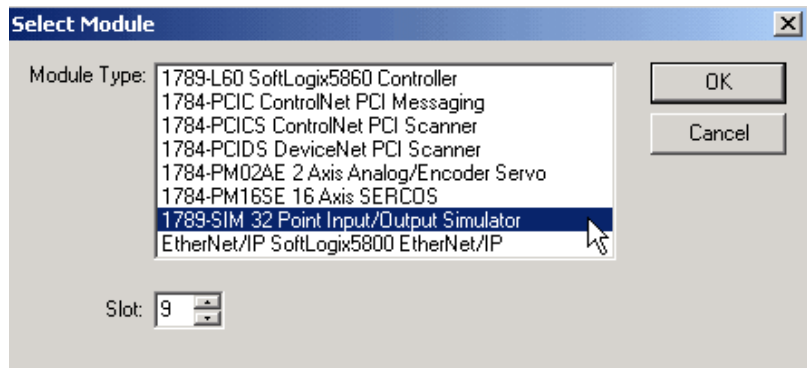

2. Choose the 1789-SIM 32 Point Input/Output Simulator.
3. Choose the slot number.

For this example, we chose slot 9.

4. Click OK.

The Select Device dialog box appears.

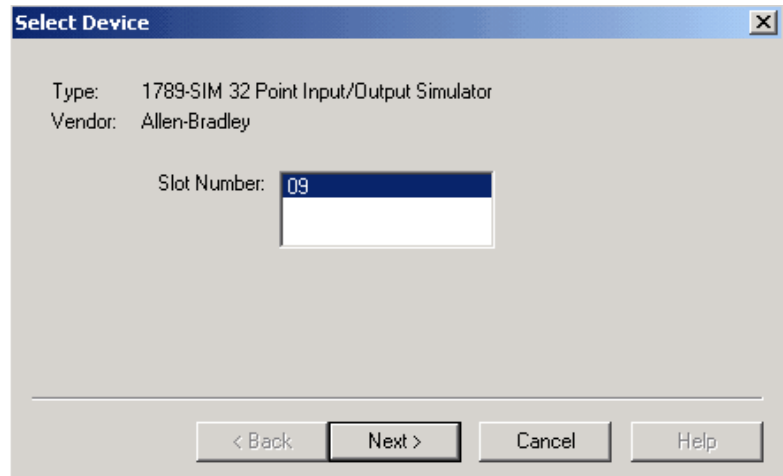

5. Verify the slot number and click Next.

The General dialog box appears.

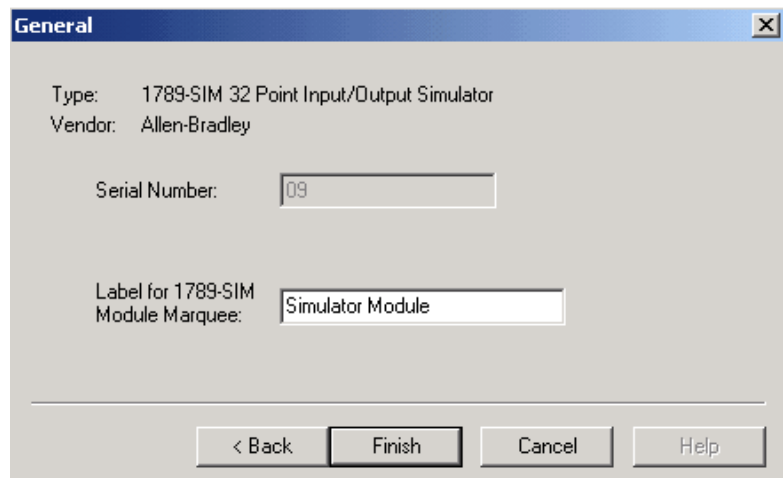

6. Enter the label name for the 1789-SIM module.

The text you enter for the module scrolls across the Marquee on the front of the module in the chassis monitor. If you do not enter a label name, the default label of 'Simulator Module' appears.

For RSLogix 5000 software, version 20.00.00 and the Logix Designer application, version 21.00.00 or later, you can specify any slot number for the 1789-SIM module, as long as the RSLinx software module is positioned in a slot other than its default 0. See [page 29](#).

The chassis monitor shows the 1789-SIM module as a virtual module in the SoftLogix Chassis Monitor. Note that the door of the 1789-SIM module opens to display the output bits.

Left-click to open or close the module door.

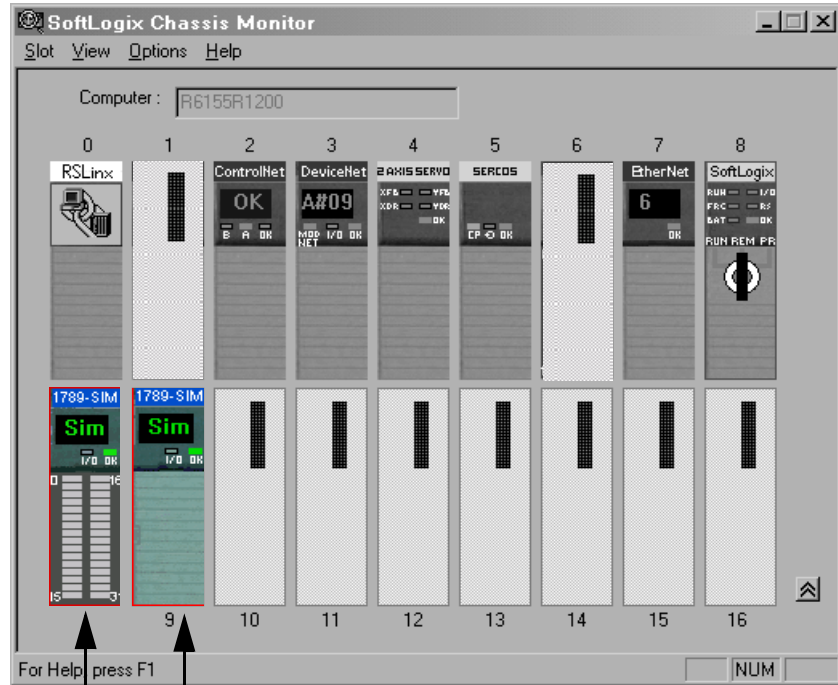

The module door is open.

The module door is closed.



## Step 2: Configure the 1789-SIM module as Part of the Project

Use the software to map the 1789-SIM module as part of the SoftLogix project.

1. In the project, right-click I/O Configuration folder, and choose New Module.

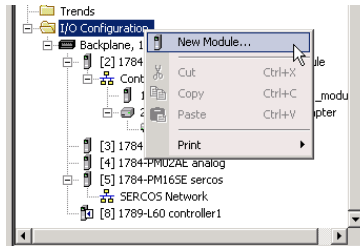

The Select Module dialog box appears.

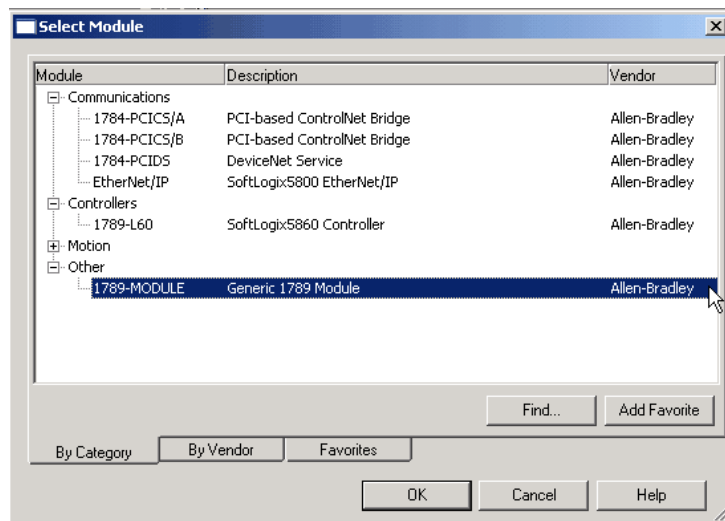

2. Select the Generic 1789 Module and click OK.

The New Module dialog box appears.

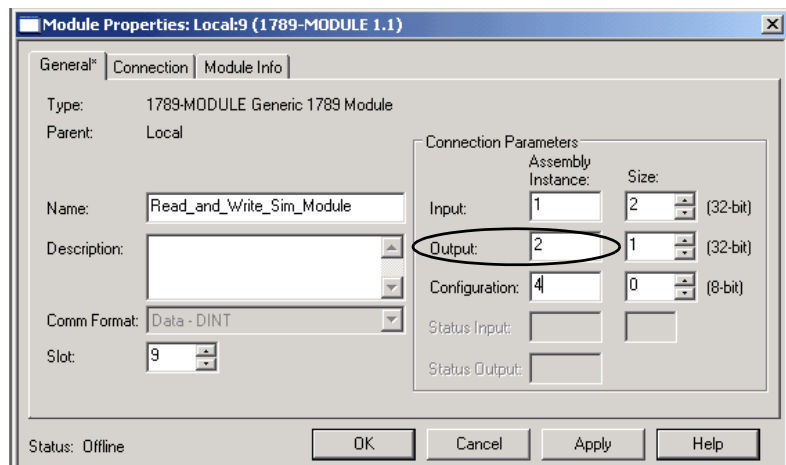

3. Enter the module parameters.

Field	Description
Type	Read and Write - This connection lets the computer read inputs and write outputs. Listen Only - This connection lets the controller read inputs, but not write outputs. The Output Assembly Instance is the only field that is different from the Read and Write connection parameters.
Name	Enter the name of the module. The name must be IEC 1131-3 compliant. This is a required field and must be completed; otherwise you receive an error message when you exit this tab. An error message is also displayed if a duplicate name is detected, or you enter an invalid character. If you exceed the maximum name length allowed by the software, the extra characters are ignored.
Description	Enter a description for the module here, up to 128 characters. You can use any printable character in this field. If you exceed the maximum length, the software ignores any extra characters.
Comm Format	Choose the communication format for the module. This field lists the available communication formats for the module. When you choose a communication format, you are also defining the configuration formats for the module. (Once you create a module, you cannot change the communication format. To change configuration, you must delete and recreate the module.)
Slot	Enter the slot number where the module resides. The values range from 0 . . . 1 less than the chassis size (for example, if you have a 4-slot chassis, the values are from 0 . . . 3). If you enter a slot number that is out of this range, you receive an error message when you go to apply your changes. The slot number cannot be changed when online.
Input Assembly Instance	Enter the input connection point for the primary connection. The default value is 1.
Output Assembly Instance	Enter the output connection point for the primary connection. The default value is 2. This parameter setting differs depending on whether the module Type is Read and Write or Listen Only.
Configuration Assembly Instance	Enter the target of the connection. The default value is 4.
Configuration Size	Enter the target of the connection. The default value is 4.
Status Input Instance	Enter the size of the configuration assembly. The configuration data type associated with this module is a fixed size (400 bytes), but only the amount of the data indicated by this parameter is sent as configuration data. The Size ranges from 0 to 400 bytes. The default value is 0 bytes.
Status Input Size	Enter the size of the input assembly for the secondary connection. The default value is 1. This field is disabled if you enter a value of 0, or if you leave it blank. It is hidden when the Comm Format does not indicate a status connection.
Status Output Instance	Enter the output connection point for the secondary connection. The default value is 6. This is field hidden when the Comm Format does not indicate a status connection.

4. Click OK.

The Connection tab on the Module Properties dialog box opens.

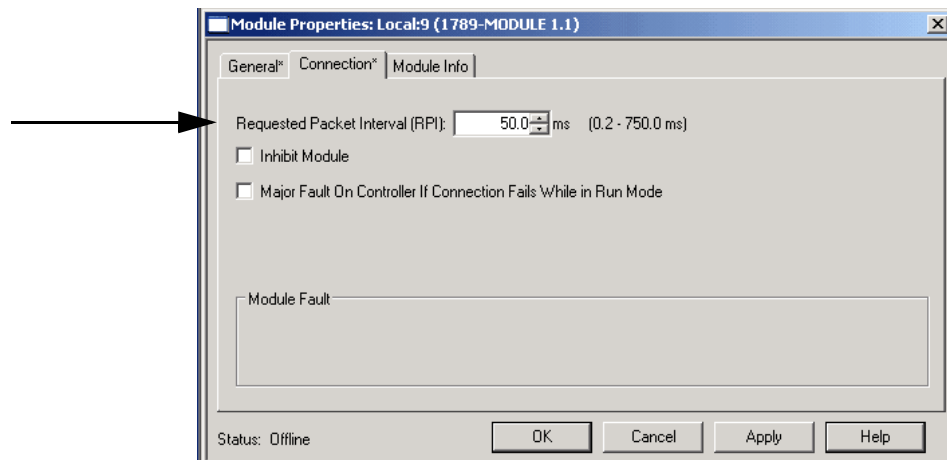

5. Specify the connection parameter; use this tab to define controller-to-module behavior.

Field	Description
Requested Packet Interval (RPI)	Enter the requested rate of packet arrival (connection update rate). The connection is scheduled to move data to or from the module at least this often. The minimum and maximum RPI values are shown parenthetically to the right of the box/spin control. The RPI is determined by the Owner Controller of a module. If a Listen Only connection is established, the RPI for that connection cannot be faster than the fastest RPI configured for all owner controllers (for input modules), or faster than the RPI configured for the one owner controller (for output modules).
Inhibit Module	Check/clear this box to inhibit/uninhibit your connection to the module. Inhibiting the module causes the connection to the module to be broken.
Major Fault on Controller If Connection Fails When in Run Mode	Check this box to configure the controller so that failure of the connection to this module causes a major fault on the controller.

**TIP** The data on this tab comes directly from the controller. This tab displays information about the condition of the connection between the module and the controller.

**IMPORTANT** You must specify an RPI of at least 50.0 ms for each 1789-SIM module or the connection to the module fails. Because this module uses the generic module profile, the default RPI is 5.0 ms.

6. Click OK.

## Map I/O Data to the 1789-SIM Module

When you add a 1789-SIM module to a project, the software automatically assigns input and output data structures for the module. For example, this I/O configuration generates these I/O data structures.

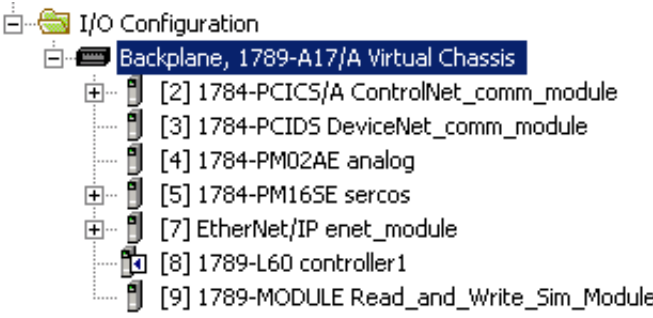
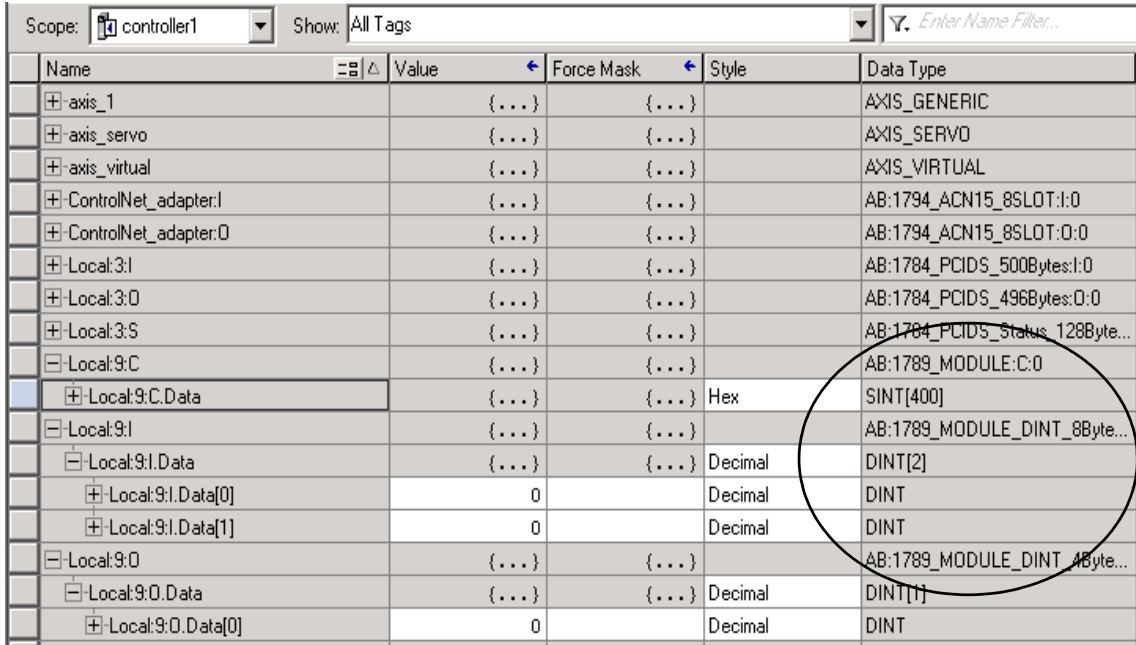
View	Description																																																																																										
I/O Configuration	<p>The SIM module is in slot 9.</p> 																																																																																										
Controller Tags	<p>The programming software assigns these controller-scoped tags to the 1789-SIM module in slot 9.</p>  <table border="1"> <thead> <tr> <th>Name</th> <th>Value</th> <th>Force Mask</th> <th>Style</th> <th>Data Type</th> </tr> </thead> <tbody> <tr><td>+ axis_1</td><td>{...}</td><td>{...}</td><td></td><td>AXIS_GENERIC</td></tr> <tr><td>+ axis_servo</td><td>{...}</td><td>{...}</td><td></td><td>AXIS_SERVO</td></tr> <tr><td>+ axis_virtual</td><td>{...}</td><td>{...}</td><td></td><td>AXIS_VIRTUAL</td></tr> <tr><td>+ ControlNet_adapter:I</td><td>{...}</td><td>{...}</td><td></td><td>AB:1794_ACN15_8SLOT:I:0</td></tr> <tr><td>+ ControlNet_adapter:O</td><td>{...}</td><td>{...}</td><td></td><td>AB:1794_ACN15_8SLOT:O:0</td></tr> <tr><td>+ Local:3:I</td><td>{...}</td><td>{...}</td><td></td><td>AB:1784_PCIDS_500Bytes:I:0</td></tr> <tr><td>+ Local:3:O</td><td>{...}</td><td>{...}</td><td></td><td>AB:1784_PCIDS_496Bytes:O:0</td></tr> <tr><td>+ Local:3:S</td><td>{...}</td><td>{...}</td><td></td><td>AB:1784_PCIDS_Status_128Byte...</td></tr> <tr><td>- Local:9:C</td><td>{...}</td><td>{...}</td><td></td><td>AB:1789_MODULE:C:0</td></tr> <tr><td>+ Local:9:C.Data</td><td>{...}</td><td>{...}</td><td>Hex</td><td>SINT[400]</td></tr> <tr><td>- Local:9:I</td><td>{...}</td><td>{...}</td><td></td><td>AB:1789_MODULE_DINT_8Byte...</td></tr> <tr><td>- Local:9:I.Data</td><td>{...}</td><td>{...}</td><td>Decimal</td><td>DINT[2]</td></tr> <tr><td>+ Local:9:I.Data[0]</td><td>0</td><td></td><td>Decimal</td><td>DINT</td></tr> <tr><td>+ Local:9:I.Data[1]</td><td>0</td><td></td><td>Decimal</td><td>DINT</td></tr> <tr><td>- Local:9:O</td><td>{...}</td><td>{...}</td><td></td><td>AB:1789_MODULE_DINT_4Byte...</td></tr> <tr><td>- Local:9:O.Data</td><td>{...}</td><td>{...}</td><td>Decimal</td><td>DINT[1]</td></tr> <tr><td>+ Local:9:O.Data[0]</td><td>0</td><td></td><td>Decimal</td><td>DINT</td></tr> </tbody> </table>	Name	Value	Force Mask	Style	Data Type	+ axis_1	{...}	{...}		AXIS_GENERIC	+ axis_servo	{...}	{...}		AXIS_SERVO	+ axis_virtual	{...}	{...}		AXIS_VIRTUAL	+ ControlNet_adapter:I	{...}	{...}		AB:1794_ACN15_8SLOT:I:0	+ ControlNet_adapter:O	{...}	{...}		AB:1794_ACN15_8SLOT:O:0	+ Local:3:I	{...}	{...}		AB:1784_PCIDS_500Bytes:I:0	+ Local:3:O	{...}	{...}		AB:1784_PCIDS_496Bytes:O:0	+ Local:3:S	{...}	{...}		AB:1784_PCIDS_Status_128Byte...	- Local:9:C	{...}	{...}		AB:1789_MODULE:C:0	+ Local:9:C.Data	{...}	{...}	Hex	SINT[400]	- Local:9:I	{...}	{...}		AB:1789_MODULE_DINT_8Byte...	- Local:9:I.Data	{...}	{...}	Decimal	DINT[2]	+ Local:9:I.Data[0]	0		Decimal	DINT	+ Local:9:I.Data[1]	0		Decimal	DINT	- Local:9:O	{...}	{...}		AB:1789_MODULE_DINT_4Byte...	- Local:9:O.Data	{...}	{...}	Decimal	DINT[1]	+ Local:9:O.Data[0]	0		Decimal	DINT
Name	Value	Force Mask	Style	Data Type																																																																																							
+ axis_1	{...}	{...}		AXIS_GENERIC																																																																																							
+ axis_servo	{...}	{...}		AXIS_SERVO																																																																																							
+ axis_virtual	{...}	{...}		AXIS_VIRTUAL																																																																																							
+ ControlNet_adapter:I	{...}	{...}		AB:1794_ACN15_8SLOT:I:0																																																																																							
+ ControlNet_adapter:O	{...}	{...}		AB:1794_ACN15_8SLOT:O:0																																																																																							
+ Local:3:I	{...}	{...}		AB:1784_PCIDS_500Bytes:I:0																																																																																							
+ Local:3:O	{...}	{...}		AB:1784_PCIDS_496Bytes:O:0																																																																																							
+ Local:3:S	{...}	{...}		AB:1784_PCIDS_Status_128Byte...																																																																																							
- Local:9:C	{...}	{...}		AB:1789_MODULE:C:0																																																																																							
+ Local:9:C.Data	{...}	{...}	Hex	SINT[400]																																																																																							
- Local:9:I	{...}	{...}		AB:1789_MODULE_DINT_8Byte...																																																																																							
- Local:9:I.Data	{...}	{...}	Decimal	DINT[2]																																																																																							
+ Local:9:I.Data[0]	0		Decimal	DINT																																																																																							
+ Local:9:I.Data[1]	0		Decimal	DINT																																																																																							
- Local:9:O	{...}	{...}		AB:1789_MODULE_DINT_4Byte...																																																																																							
- Local:9:O.Data	{...}	{...}	Decimal	DINT[1]																																																																																							
+ Local:9:O.Data[0]	0		Decimal	DINT																																																																																							

## Toggle Inputs and Monitor Outputs

Once the 1789-SIM module is installed in the SoftLogix Chassis Monitor, you can monitor the module. Follow these steps.

1. In the SoftLogix Chassis Monitor, right-click SIM module and choose Properties.

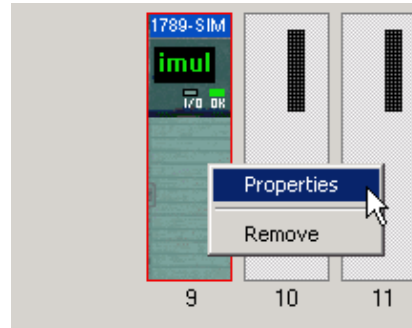

The Module Properties dialog box appears.

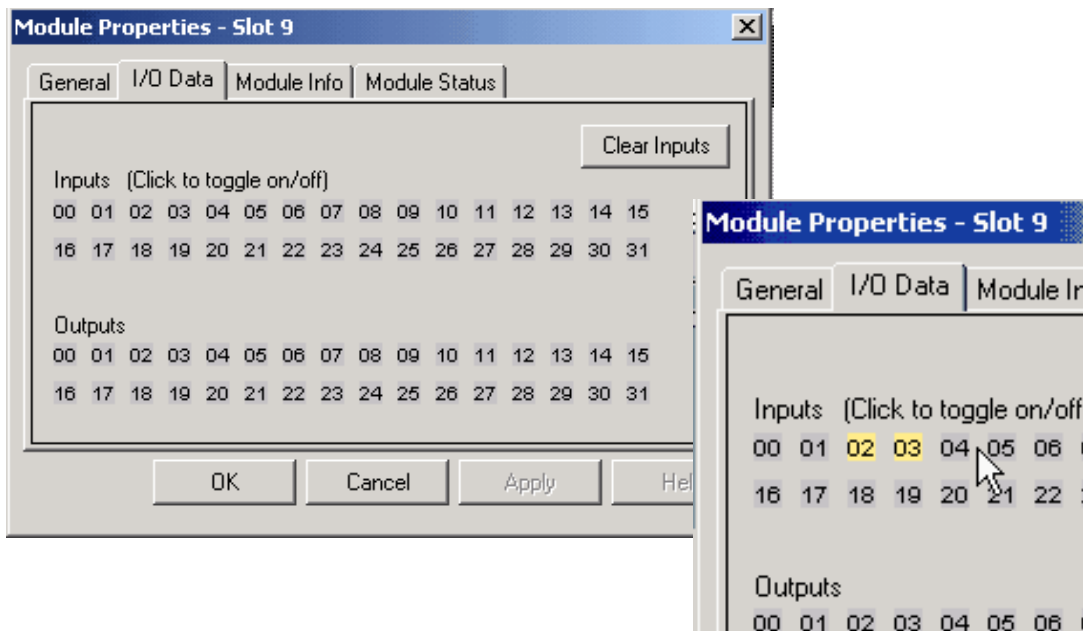

2. Click the I/O tab.
3. Click a specific input bit to toggle it on or off.

This tab also shows the state of the output bits. This is the same state that is displayed when you open the module door from the chassis monitor.

Outputs remain in last state when the controller is in Program mode (this is not user configurable). If the I/O connection is broken to the module, all of the outputs reset to OFF.

## Turn On or Force a Bit

You can use the second address of input I/O tags to turn on, or force an I/O bit, in the SIM module.

Notice that there is one output value tag address available in the tag database, but two input value tag addresses that can be used. Always use the second input bit value address to force or turn on a bit (Local:9:I.Data[1]).

1

	[-] Local:9:I	{...}	{...}		AB:1789_MC
	[-] Local:9:I.Data	{...}	{...}	Decimal	DINT[2]
2	➔ [+Local:9:I.Data[0]	0		Decimal	DINT
3	➔ [+Local:9:I.Data[1]	0		Decimal	DINT
	[-] Local:9:O	{...}	{...}		AB:1789_MC
	[-] Local:9:O.Data	{...}	{...}	Decimal	DINT[1]
4	➔ [+Local:9:O.Data[0]	0		Decimal	DINT

Item	Description
1	Tag database is the location where tag data is stored for the project.
2	+Local:9:I.Data[0] - Input tag address.
3	+Local:9:I.Data[1] - Input tag address used to turn on or force a bit.
4	+Local:9:O.Data[0] - Output tag address.

---

**IMPORTANT** You must use +Local:9:I.Data[1] when trying to turn on or force a bit for the SIM module.

---

## Example: Move Application Data into the 1789-SIM Tags

This example uses MOV instructions to copy:

- Input data from the 1789-SIM module into the application's input tags
- Application's output tags into the output data for the 1789-SIM module

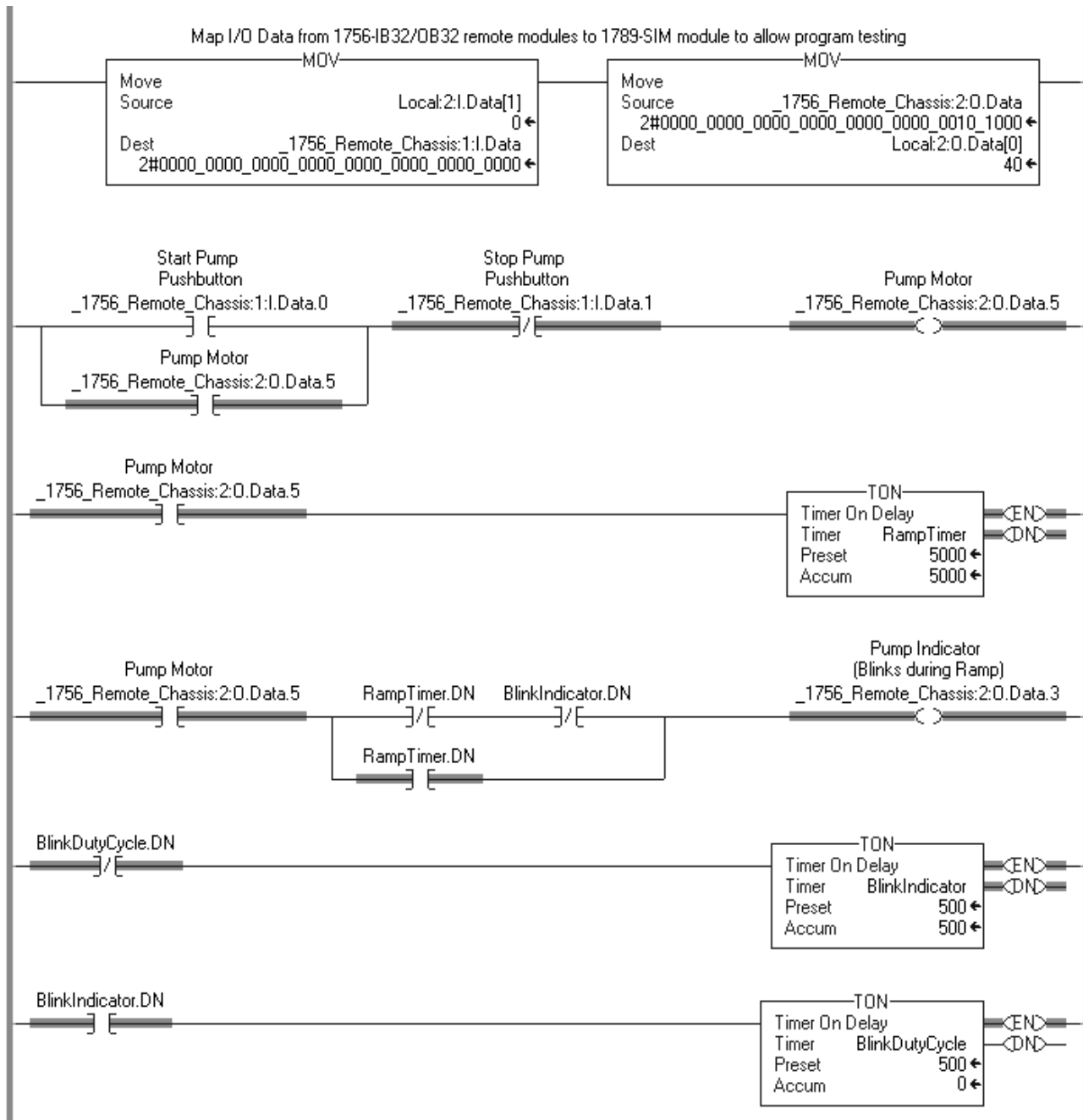

**Notes:**



## Execute External Routines

Topic	Page
Configure Your System to Execute an External Routine	105
Add an External Routine to the Controller Organizer	106
Call an External Routine	112
Type Checking	114

This chapter explains how to add external routines to your project.

External routines are programs or functions developed outside of the Studio 5000 environment by using commonly available programming languages, such as C or C++. If an external routine is properly developed as a Windows DLL, the SoftLogix controller can execute the routine as part of a Logix Designer application project.

### Configure Your System to Execute an External Routine

For the SoftLogix controller to execute an external routine, you need to do the following:

- Add the external routine to the Controller Organizer.
- Use a JXR instruction within a relay ladder routine to call the external routine.

## Add an External Routine to the Controller Organizer

You add an external routine to the Controller Organizer the same way you create a new ladder routine.

Follow these steps.

1. In the Logix Designer application, right-click Main Program folder in the Controller Organizer and choose New Routine.

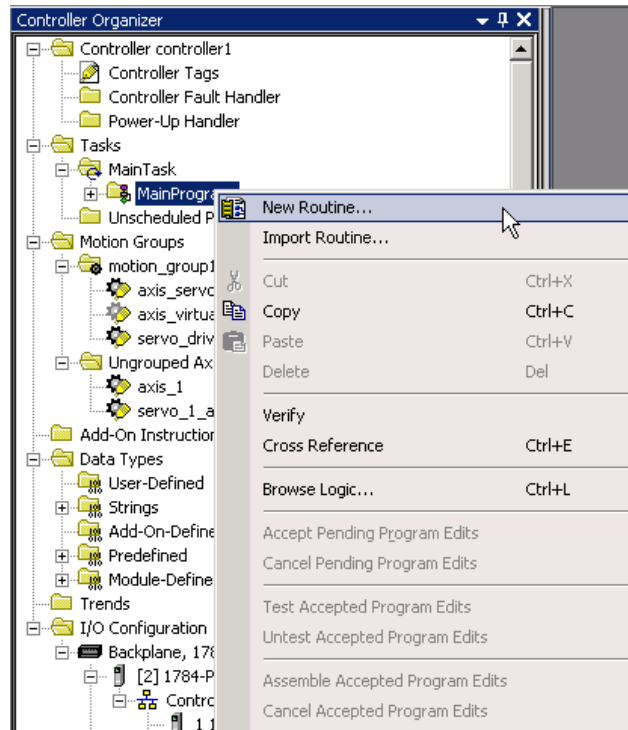

The New Routine dialog box appears.

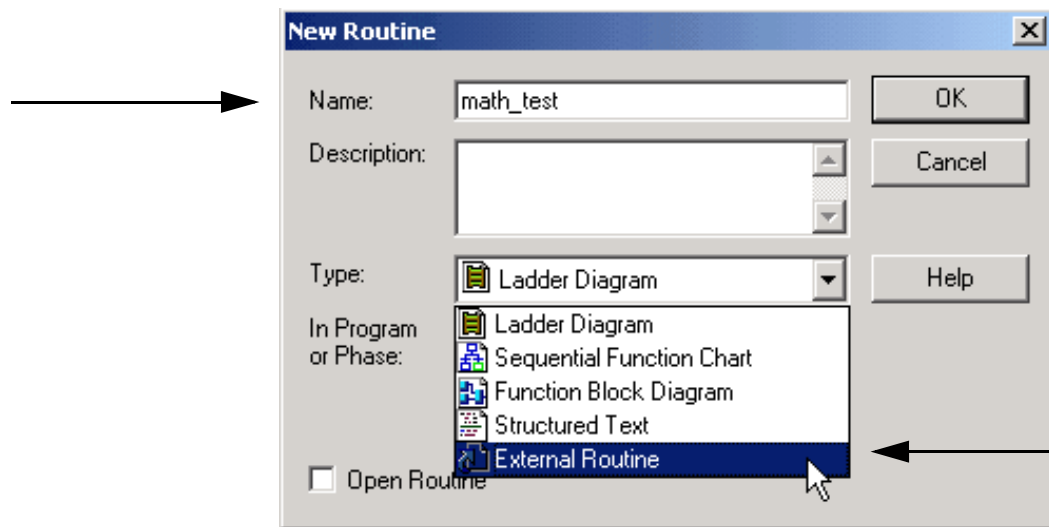

2. Name the new routine.

In this example, we named it 'math\_test.'

3. From the Type pull-down menu, choose External Routine.
4. Click OK.

The new routine now appears in the Controller Organizer under the Main Program.

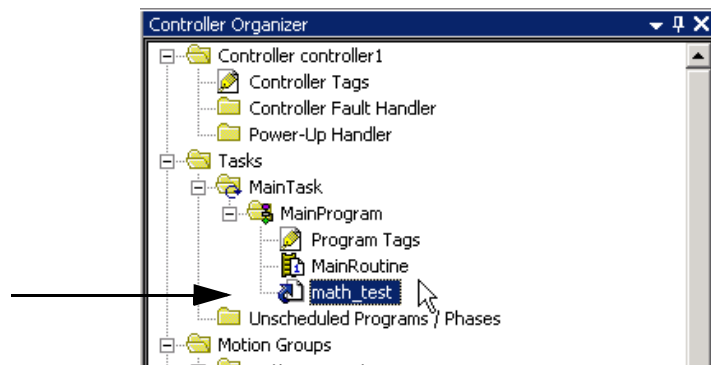

5. Right-click new routine and choose Open.

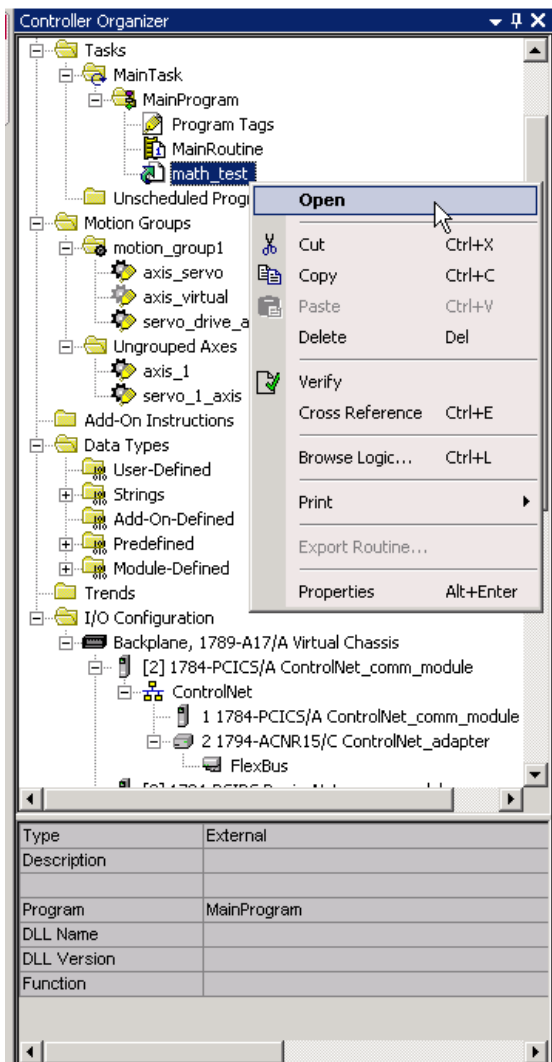

Use the quick view pane of the Controller Organizer to verify that you specified the external routine DLL and function that you wanted.

The Routine Properties dialog box appears.

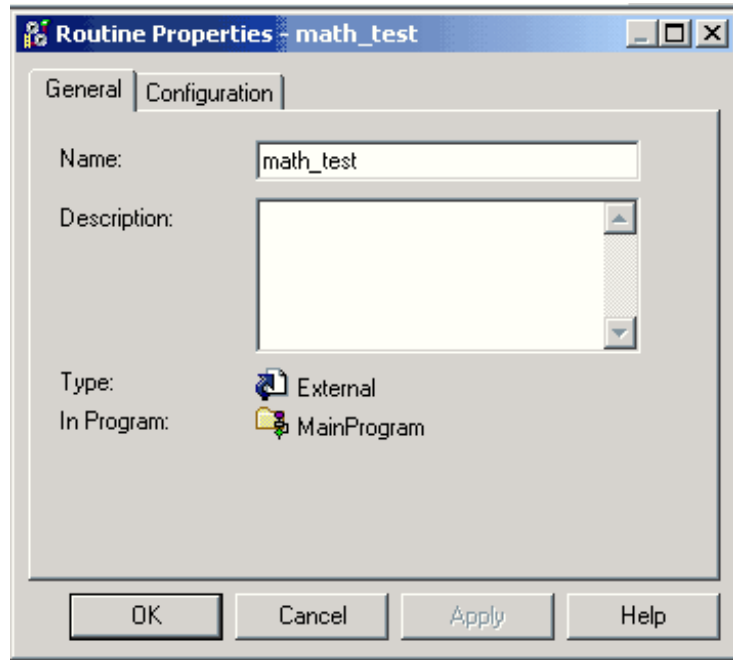

6. On the General tab, verify that the information for the external routine is correct and that it appears this way in the Controller Organizer.
7. On the Configuration tab, click Browse to select the DLL file that contains the function you want to execute.

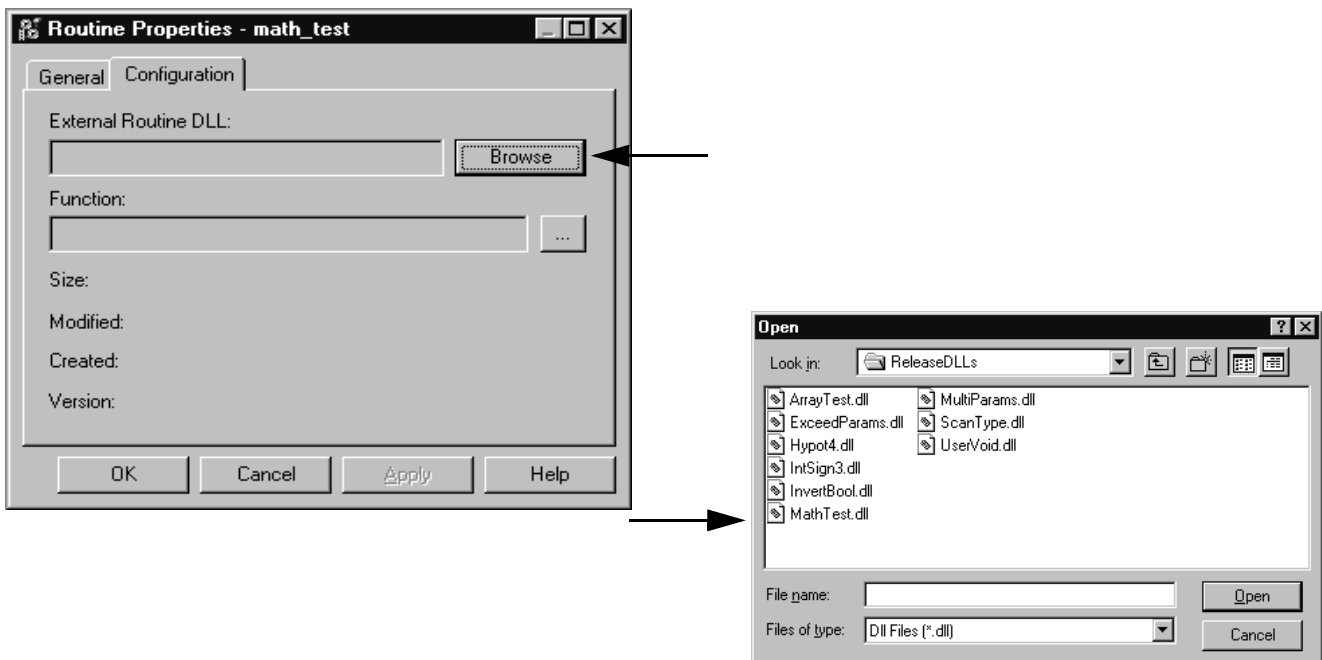

8. On the Configuration tab, click Function and choose the DLL you want to execute.

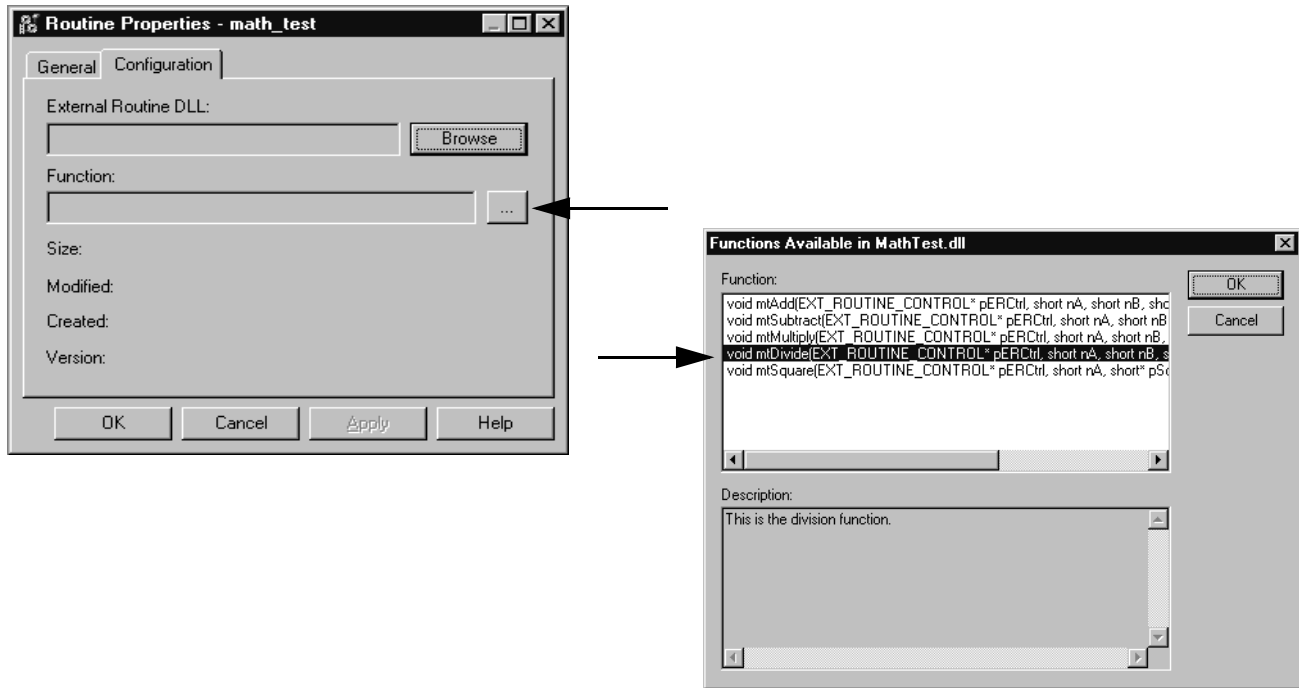

9. Click OK.

## How the Project Stores and Downloads an External Routine

To use an external routine, you must associate (also known as ‘map’) a DLL file to an external routine that you create in the Controller Organizer of a project (see [Add an External Routine to the Controller Organizer](#)). You choose the DLL file that contains the function you want to execute. The software makes a copy of that DLL and stores it in the external routine folder located in the project directory, in a sub-folder named the same as the project file. For example, if the project MyProject.ACD is in

C:\Users\

mapping a DLL to that project stores a copy of the DLL file in the directory:

C:\Users\

When you download the project to the controller, the mapped DLL is also downloaded to the target controller and a copy of the DLL is placed in the slot directory of the controller. For example, if you download MyProject.ACD to a controller in slot 4, the external routine DLL file is downloaded to the location C:\Program Files\Rockwell Automation\SoftLogix5800\Data\slot04 on the SoftLogix controller.

Because this process creates copies of the original DLL file, you can execute different versions of the same DLL on SoftLogix controllers in different slots of the same virtual chassis. The DLL used by a controller in one slot is completely independent of the DLL used by a controller in another slot. For this reason, if you update a DLL, you re-map the DLL in each project and re-download the updated projects to the appropriate controllers.

Linking an individual DLL file to a specific controller and slot is useful for debugging changes or testing new versions of an external routine. You can load different versions into controllers in different slots without having to actually update controllers that are performing plant control.

---

**IMPORTANT** If you want to use a copy of a project on another workstation, take care when making a copy of a project that includes an external routine. In addition to the ACD file, you must also copy the external routines folder that contains all of the DLL files associated with that ACD file.

---

## Call an External Routine

Use the Jump to External Routine (JXR) instruction to call the external routine from a ladder routine in your project. The JXR instruction supports multiple parameters so you can pass values between the ladder routine and the external routine.

### Jump to External Routine (JXR)

The JXR instruction executes an external routine. This instruction is supported only by the SoftLogix5800 controllers.

### Operands

Table 7 - Relay Ladder

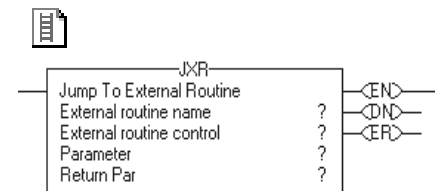

Operand	Type	Format	Description
External routine name	ROUTINE	Name	External routine to execute.
External routine control	EXT_ROUTINE_CONTROL	Tag	See <a href="#">page 113</a> .
Parameter	BOOL SINT INT DINT REAL Structure	Immediate Tag Array tag	Data from this routine that you want to copy to a variable in the external routine: <ul style="list-style-type: none"> <li>Parameters are optional.</li> <li>Enter multiple parameters, if needed.</li> <li>You can have as many as 10 parameters.</li> </ul>
Return parameter	BOOL SINT INT DINT REAL	Tag	Tag in this routine to which you want to copy a result of the external routine: <ul style="list-style-type: none"> <li>The return parameter is optional.</li> <li>You can have only one return parameter.</li> </ul>



**Table 8 - EXT\_ROUTINE\_CONTROL Structure**

Mnemonic	Data Type	Description	Implementation
ErrorCode	SINT	If an error occurs, this value identifies the error. Valid values are from 0...255.	There are no predefined error codes. The developer of the external routine must provide the error codes.
NumParams	SINT	This value indicates the number of parameters associated with this instruction.	Display only - this information is derived from the instruction entry.
ParameterDefs	EXT_ROUTINE_PARAMETERS[10]	This array contains definitions of the parameters to pass to the external routine. The instruction can pass as many as 10 parameters.	Display only - this information is derived from the instruction entry.
ReturnParamDef	EXT_ROUTIN_PARAMETERS	This value contains definitions of the return parameter from the external routine. There is only one return parameter.	Display only - this information is derived from the instruction entry.
EN	BOOL	When set, the enable bit indicates that the JXR instruction is enabled.	The external routine sets this bit.
ReturnsValue	BOOL	If set, this bit indicates that a return parameter was entered for the instruction. If cleared, this bit indicates that no return parameter was entered for the instruction.	Display only - this information is derived from the instruction entry.
DN	BOOL	The done bit is set when the external routine has executed once to completion.	The external routine sets this bit.
ER	BOOL	The error bit is set if an error occurs. The instruction stops executing until the program clears the error bit.	The external routine sets this bit.
FirstScan	BOOL	This bit identifies whether this is the first scan after switching the controller to Run mode. Use FirstScan to initialize the external routine, if needed.	The controller sets this bit to reflect scan status.
EnableOut	BOOL	Enable output.	The external routine sets this bit.
EnableIn	BOOL	Enable input.	The controller sets this bit to reflect rung-condition-in. The instruction executes regardless of rung condition. The developer of the external routine should monitor this status and act accordingly.
User1	BOOL	These bits are available for the user. The controller does not initialize these bits.	Either the external routine or the user program can set these bits.
User0	BOOL		
ScanType1	BOOL	These bits identify the current scan type: <b>Bit Values      Scan Type</b> 00              Normal 01              Pre Scan 10              Post Scan (not applicable to relay ladder programs)	The controller sets these bits to reflect scan status.
ScanType0	BOOL		

## Description

The JXR instruction is similar to the Jump to Subroutine (JSR) instruction. The JXR instruction initiates the execution of the specified external routine:

- The external routine executes one time.
- After the external routine executes, logic execution returns to the routine that contains the JXR instruction.

## Arithmetic Status Flags

Arithmetic status flags are not affected.

## Fault Conditions

This table describes major fault conditions.

A major fault occurs if	Fault type	Fault code
<ul style="list-style-type: none"> <li>An exception occurs in the external routine DLL.</li> <li>The DLL could not be loaded.</li> <li>The entry point was not found in the DLL.</li> </ul>	4	88

## Execution

The JXR can be synchronous or asynchronous depending on the implementation of the DLL. The code in the DLL also determines how to respond to scan status, rung-condition-in status, and rung-condition-out status.

## Type Checking

This table describes the type checking that occurs between the Logix Designer application and the external routine for the parameters that they pass.

Data Type	C++ Type	Passing Method	Type Checking	Arrays
BOOL	Bool	By reference	Strong type checking	By reference Array sizes are not checked, but the size information is passed through the control structure
INT	Short	By value		
DINT	Long Int			
SINT	Char			
REAL	Float			
User-defined structure	Structure	By reference	Weak type checking The check determines whether a structure is being passed to a structure parameter. Data types and sizes are not checked.	By reference Array sizes are not checked, but the size information is passed through the control structure

For more details on creating a DLL by using Visual Studio, see [Create a Visual Studio Project on page 117](#).

## Develop External Routines

Topic	Page
Considerations For External Routines	115
How the SoftLogix Controller Executes External Routines	116
Create Synchronous, Single-threaded External Routines	117
Project Files	118
Create an HTML Resource	123
Add Version Information to an External Routine DLL	128
Build and Download External Routines	130
Update an Existing External Routine	130
Create Multi-threaded External Routines	130
Debug External Routines	136
Data Type Support	138
Export Functions by Using C++ Export Style	145
Other Considerations	147

This chapter describes how to use Microsoft Visual Studio to create external routines. Instructions include how to use ‘Test Mode’ in detail, so that you can test your external routine prior to running the routine with the controller’s outputs enabled.

A SoftLogix 5800 controller executes an external routine as specified by a JXR instruction.

### Considerations For External Routines

The external routines feature is an extremely flexible and powerful capability of the SoftLogix 5800 product. The routines can be written in C or C++ when using any commercial off-the-shelf development tool, such as Microsoft Visual Studio, that can generate a Windows compatible DLL (dynamic link library). The SoftLogix controller at runtime performs a ‘LoadLibrary’ to invoke the external routine DLL’s code from within the memory and process space of the SoftLogix 5800 controller.

Because the user’s external routine DLL runs in the memory and process space of the SoftLogix 5800 controller, it is possible that incorrectly written user code can errantly overwrite memory locations that are being used by the controller. Care must also be taken when creating threads and assigning priorities, because this can also impact the operation of the SoftLogix 5800 controller.

---

**IMPORTANT** If proper procedures are not followed, it is possible that the controller may respond in an unpredictable manner.

---

Due to the requirements of this feature it is not possible for Rockwell Automation to safeguard and protect from certain scenarios that may interfere with the operation of the controller and result in unpredictable behavior.

Carefully read and follow the recommendations in this chapter. This chapter describes how to test an external routine in the Microsoft debugger and run it under normal operation with the controller placed in 'Test Mode' so that outputs are not energized. Thorough testing must be performed in Test Mode prior to running the external routine with the controller's outputs enabled.

Because of the variety of uses for external routines, those responsible for the application and use of this control equipment must satisfy themselves that all necessary steps have been taken to assure that the application and use meets all performance and safety requirements, including any applicable laws, regulations, codes and standards. Rockwell Automation does not assume responsibility or liability (to include intellectual property liability) for actual use of the external routines feature in a control system application.

## How the SoftLogix Controller Executes External Routines

An external routine lets the SoftLogix controller execute a function that was developed outside of the Studio 5000 environment. The external routine must be a standard Windows DLL and it can contain one or more functions. An external routine can execute synchronously or asynchronously, depending on how the code is written in the external routine DLL. You can develop the DLL in C or C++ and export the functions of that DLL in C or C++.

You make these exported functions available to the SoftLogix controller by including XML information. The XML information describes the exported function.

Once you add an external routine to a project, the DLL is downloaded to the SoftLogix controller when you download the project. The SoftLogix controller loads the DLL by using a LoadLibrary Windows call during the download process. The SoftLogix controller uses a GetProcAddress Windows call to locate the exported function so that the function can be executed by an associated JXR instruction in the ladder program.

The external routine is executed in the process space of the SoftLogix controller. Spawning threads and processes are techniques you can use to make the JXR instruction for the external routine execute asynchronous to the ladder scan. If you spawn a thread, the external routine and the spawned thread both run in the process space of the controller. If you spawn another process, the external routine runs in the process space of the controller while the newly spawned process runs in its own process space.

## How the Project Stores and Downloads an External Routine

To use an external routine, you must associate (also known as ‘map’) a DLL file to an external routine that you create in the Controller Organizer of a project (as shown in [Chapter 6](#)). You choose the DLL file that contains the function you want to execute. The Logix Designer application makes a copy of that DLL and stores it in the external routine folder located in the project directory, in a sub-folder named the same as the project file. For example, if the project MyProject.ACD is in C:\Users\\Documents\Studio5000\Projects, mapping a DLL to that project stores a copy of the DLL file in the directory: C:\Users\\Documents\Studio5000\Projects\ExternalRoutines\MyProject\.

When you download the project to the controller, the mapped DLL is also downloaded to the target controller and a copy of the DLL is placed in the slot directory of the controller. For example, if you download MyProject.ACD to a controller in slot 4, the external routine DLL file is downloaded to the location C:\Program Files\Rockwell Automation\SoftLogix 5800\Data\slot04 on the SoftLogix controller.

Because this process creates copies of the original DLL file, you can execute different versions of the same DLL on SoftLogix controllers in different slots of the same virtual chassis. The DLL used by a controller in one slot is completely independent of the DLL used by a controller in another slot. For this reason, if you update a DLL, you re-map the DLL in each project and re-download the updated projects to the appropriate controllers.

Linking an individual DLL file to a specific controller and slot can be useful for debugging changes or testing new versions of an external routine. You can load different versions into controllers in different slots without having to actually update controllers that are performing plant control.

---

**IMPORTANT** If you want to use a copy of a project on another workstation, take care when making a copy of a project that includes an external routine. In addition to the ACD file, you must also copy the external routines folder that contains all of the DLL files associated with that ACD file.

---

## Create Synchronous, Single-threaded External Routines

This type of external routine runs synchronously in the process space of the control engine. Use this type of routine when the execution time of the function does not significantly impact the overall ladder scan time or cause a watchdog fault in the controller. A watchdog fault is a major fault that occurs because a scan of the routine did not complete within the expected amount of time.

## Create a Visual Studio Project

Complete these steps to create a project in Visual Studio.

1. Launch Visual Studio software.
2. From the File menu, choose New and name the project.

For this example, our Project name is InlineExample.

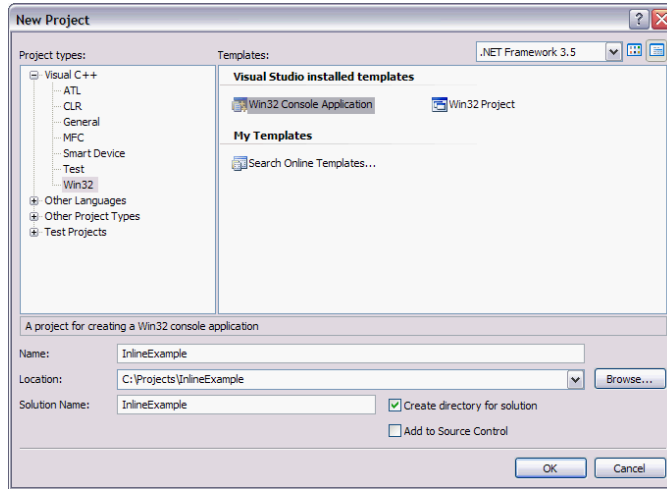

3. From the Visual C++ folder, choose Win32, and choose the Win32 Console Application template.

The Win32 Application Wizard launches.

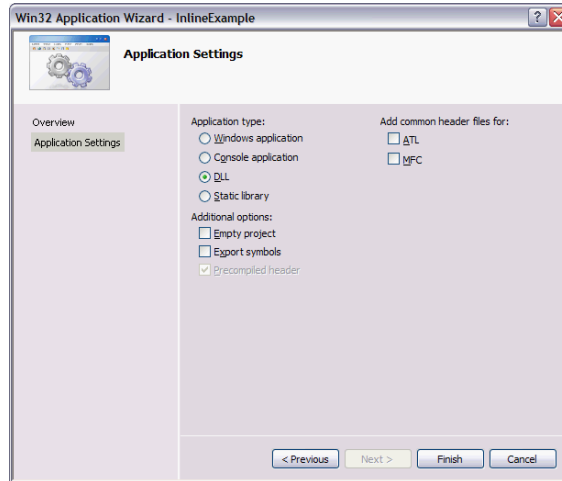

4. Click the DLL Application type.
5. Click Finish.

The software displays the type of files it will generate for the project.

## Project Files

Add external routine code to the project files. All calls to external routines require that you pass an external routine control structure as the first parameter in the call. The DLL developer must use the Rockwell Automation supplied header file that describes the control structure. Below is the text of the header file along with a description of how various parts of the control structure should be used by the external routine DLL developer.

**RA\_ExternalRoutines.h**

```

#ifndef __RA_EXTROUTINE_H__
#define __RA_EXTROUTINE_H__

#define MAX_PARAMS 10

/*          MSC assumes LSB first, 32 bit integers */

#pragma pack(push,1)

struct RoutineControlWord          // 4 bytes (32 bit word) total
{
    unsigned ErrorCode : 8;        // Error code if ER bit is set.
    // -- end byte 0 --
    unsigned NumParams : 8;       // From 0 to MAX_PARAMS,
    // -- end byte 1 --          excludes control structure
    unsigned ScanType : 2;        // 16-17 Normal, Pre, Post (0, 1, 2)
    unsigned ReservedA : 2;       // 18-19 Reserved Set A: DO NOT USE
    unsigned User : 2;           // 20-21 Defined by Ext Rtn developer
    unsigned ReservedC : 2;       // 22-23 Reserved Set C: DO NOT USE
    // -- end byte2 --
    unsigned EnableIn : 1;        // 24 Incoming rung status
    unsigned EnableOut : 1;       // 25 Returning rung status
    unsigned FirstScan : 1;       // 26 First Normal Scan occurring
    unsigned ER : 1;             // 27 Control ERROR
    unsigned ReservedB : 1;       // 28 Reserved Set B: DO NOT USE
    unsigned DN : 1;             // 29 Control DONE
    unsigned ReturnsValue : 1;    // 30 Indicates if routine returns anything
    unsigned EN : 1;             // 31 Control ENABLE
    // -- end byte 3 --
};

#pragma pack(pop)
enum EXT_ROUTINE_PARAM_TYPE_E // 4 bytes long

{
    FloatingPointValue = 0,      // e.g., float p
    FloatingPointAddress,       // e.g., float* p
    IntegerValue,               // e.g., short p
    IntegerAddress,             // e.g., long* p
    ArrayAddress,               // e.g., int p[]
    StructureAddress,           // e.g., MyStructT* p
    VoidAddress,                // e.g., void* p
    Void,                       // e.g., "No return value"
    LastEntryInEnum
};

// Structure representing the type of the parameter defined
// for the External Routine.
struct EXT_ROUTINE_PARAMETERS // 12 bytes long
{
    // Size of parameter/array element in bits
    unsigned long bitsPerElement;

    // If array, number of elements else 1.
    unsigned long numberOfElements;

    // Numeric representation and reference type.
    EXT_ROUTINE_PARAM_TYPE_E paramType;
};

```

The control structure for an external routine contains control, status, and meta information for that routine. The control structure is accurate at the time of its invocation and it enables the external routine to validate and influence its operation. Upon routine completion, the control structure contains status about the routine's execution as to its degree of success or failure. Other data areas are either reserved or defined by you.

The meta information includes the definitions of the parameters passed to the external routine (`paramDefs`) and the parameter that is returned from the routine (`returnDef`). The meta information is read-only. It is derived at download time and then set upon every call to its corresponding external routine. These definitions let the external routine determine if it is being used in the proper context. The routine can check this information, which includes a parameter's type, the number of elements in the event of an array, and the number of bits in each of these elements.

The remaining meta information exists in the `ctrlWord`: the number of parameters (`numParams`), whether a return value (`ReturnsValue`) is expected by the caller, and whether it's executing during Normal, Pre, or Post scan (`ScanType`). All the meta information is set by the system and the external routine developer should treat it as read-only. Any modifications to this information is disregarded.

Control and status information exist in one location inside the `RoutineControlWord` structure (`ctrlWord`) within the external routine control. Control information consists of `EnableIn` and `FirstScan`. This information is set upon every invocation of the external routine. `EnableIn` reflects the rung status at the time of the call. `FirstScan` indicates whether this is the first scan after switching the controller to Run mode. Use `EnableIn` to enable operation of the external routine and use `FirstScan`, or possibly `Prescan`, to perform any necessary initialization in the external routine.

Status information is set by the external routine. The `Enable (EN)`, `Done (DN)`, and `Error (ER)` bits are used much like other ladder control structures. Set the `EN` bit when the external routine is enabled. Set the `DN` bit when the operation is complete. If an error occurs during execution, set the `ER` bit and store an error code in the `ErrorCode` member.

Another piece of status information is `EnableOut`. Set this bit if the external routine is used to compute rung status and the result indicates a `TRUE` condition. The system does not however update system rung status based on this information. It is used as an indication to the caller.

The controller does not modify or initialize the user defined bits (`User`). The use of these bits is up to the external routine developer.

```
// Fixed size structure defining JXR's signature and control.
struct EXT_ROUTINE_CONTROL // 4 + 120 + 12 = 136 bytes long
{
    RoutineControlWord          ctrlWord;
    EXT_ROUTINE_PARAMETERS     paramDefs[MAX_PARAMS];
    EXT_ROUTINE_PARAMETERS     returnDef;
};
```



**InlineExample.cpp**

```

// InlineExample.cpp : Defines the entry point for the DLL application.

#include "stdafx.h"
//Include file for External Routine interface
#include "RA_ExternalRoutines.h"

BOOL APIENTRY DllMain( HANDLE hModule,
                      DWORD ul_reason_for_call,
                      LPVOID lpReserved
                      )
{
    switch (ul_reason_for_call)
    {
        case DLL_PROCESS_ATTACH:
        case DLL_THREAD_ATTACH:
        case DLL_THREAD_DETACH:
        case DLL_PROCESS_DETACH:
            break;
    }
    return TRUE;
}
// This is an example of an exported function.
extern "C" __declspec(dllexport) int SumArray(
                                EXT_ROUTINE_CONTROL* pERCtrl,
                                int Val[])
{
    // Add all array elements provided, then return the Sum.

    pERCtrl->ctrlWord.EN = pERCtrl->ctrlWord.EnableIn;
    pERCtrl->ctrlWord.EnableOut = pERCtrl->ctrlWord.EnableIn;

    BOOL bFail = FALSE;

    // Number of parameters expected is 1 (exclude ctrl struct*), and
    // Check type of parameter against what is expected, and
    // Check size of array elements to make sure they agree with int type.
    if (pERCtrl->ctrlWord.NumParams != 1)
        bFail = TRUE;
    else if ( (pERCtrl->paramDefs[0].paramType != ArrayAddress) ||
              (pERCtrl->paramDefs[0].bitsPerElement != 8*sizeof(int)) )
        bFail = TRUE;

    // Check number of array elements
    int nNoElems = pERCtrl->paramDefs[0].numberOfElements;

    if (nNoElems == 0)
        bFail = TRUE;

    int itemp = 0; // Initialize sum to zero

    if (pERCtrl->ctrlWord.EnableIn)
    {
        // Rung enabled, run the function's implementation
        if (!bFail)
        {
            // Sum all array elements
            for (int j = 0; j < nNoElems; j++)
                itemp += Val[j];
        }
    }
}

```

```
        // Set Error bit to zero if successful.
        pERCtrl->ctrlWord.ER = 0;
    }
    else
    {
        // Some error
        // Set Error bit to indicate error occurred
        pERCtrl->ctrlWord.ER = 1;
        pERCtrl->ctrlWord.ErrorCode = 1; // Set ErrorCode
    }

    // Set Done bit before exit of this XR.
    pERCtrl->ctrlWord.DN = 1;
}
else
{
    // Rung not enabled
    pERCtrl->ctrlWord.DN = 0;
}

return itemp; // returns 0.0 if error
}
```

### InlineExample.h

```
// Exported Functions:
extern "C" __declspec(dllimport) int SumArray(
    EXT_ROUTINE_CONTROL* pERCtrl,
    int Val[]);
```

## Create an HTML Resource

The HTML resource does the following:

- Describes the external routines that are contained in the DLL
- Provides descriptions that the Logix Designer application uses
- Provides type checking in the JXR instruction
- Gets the name of the routine to be used in the GetProcAddress call

The information stored in the HTML resource is in XML. Use an HTML resource because Visual Studio does not support an XML resource.

Complete these steps to create an HTML resource.

1. From the View menu, choose Resource View.

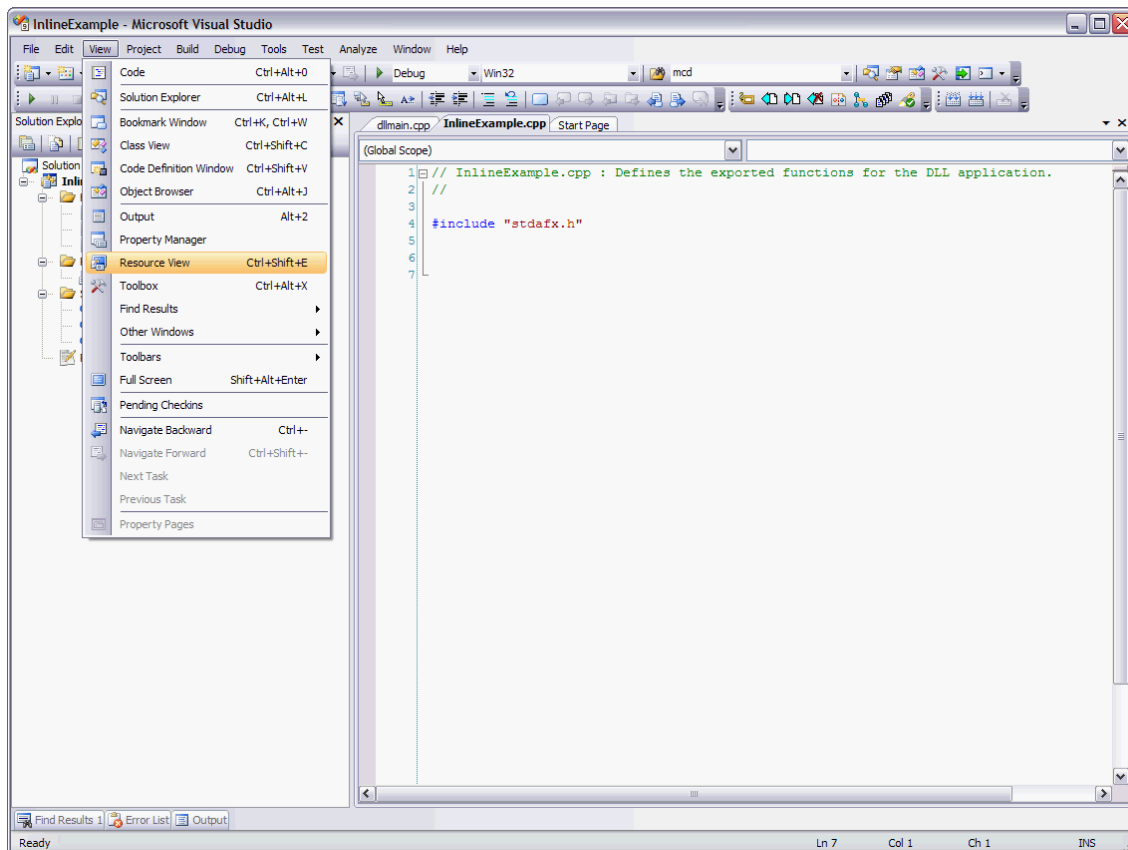

The Resource View dialog box appears.

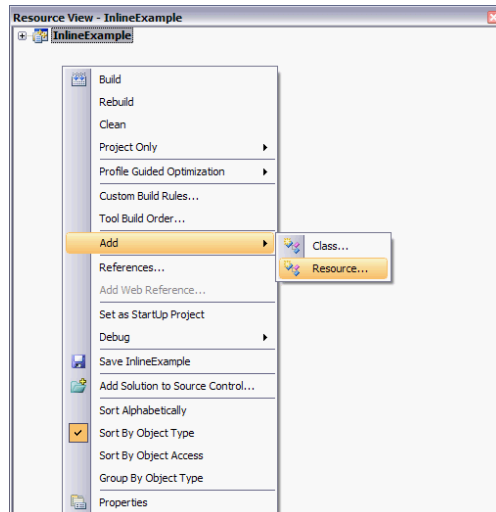

2. In the InlineExample, right-click Add and choose Resource.

The Add Resource dialog box appears.

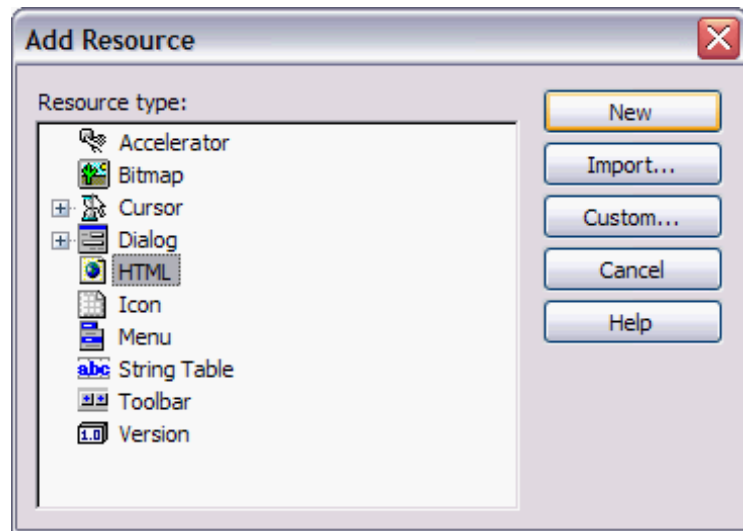

3. Choose HTML as the resource type and click New.

- Open the new resource. Choose the IDR\_HTML1 file from the HTML folder.

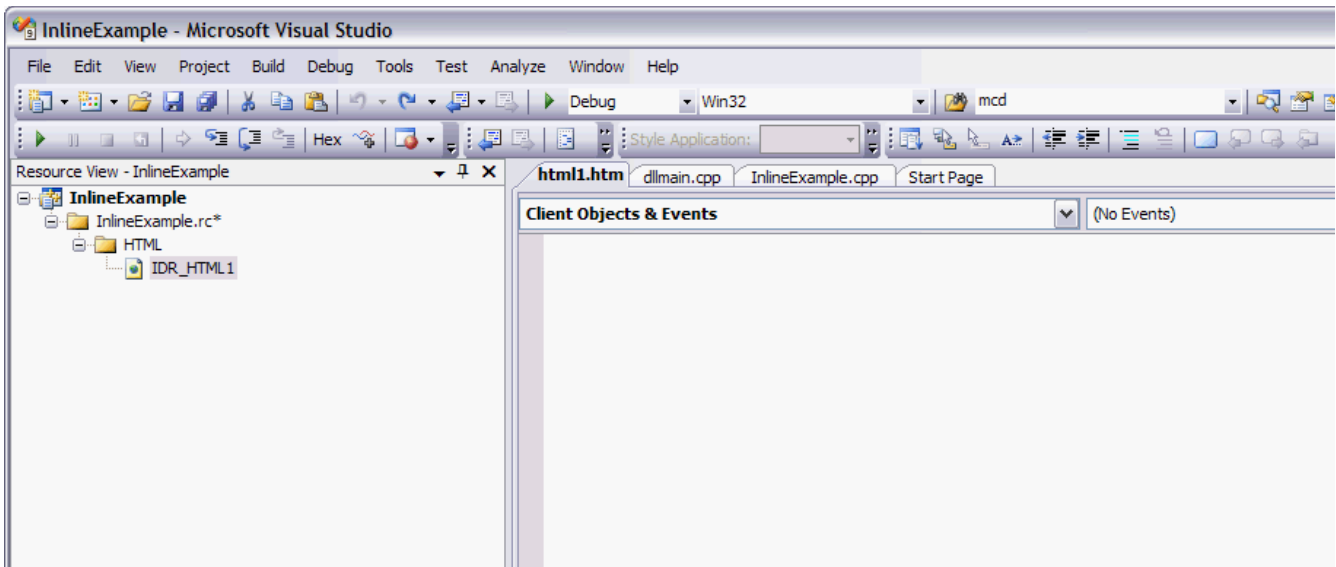

- Choose the Client Objects & Events.

The HTML code for the project example appears.

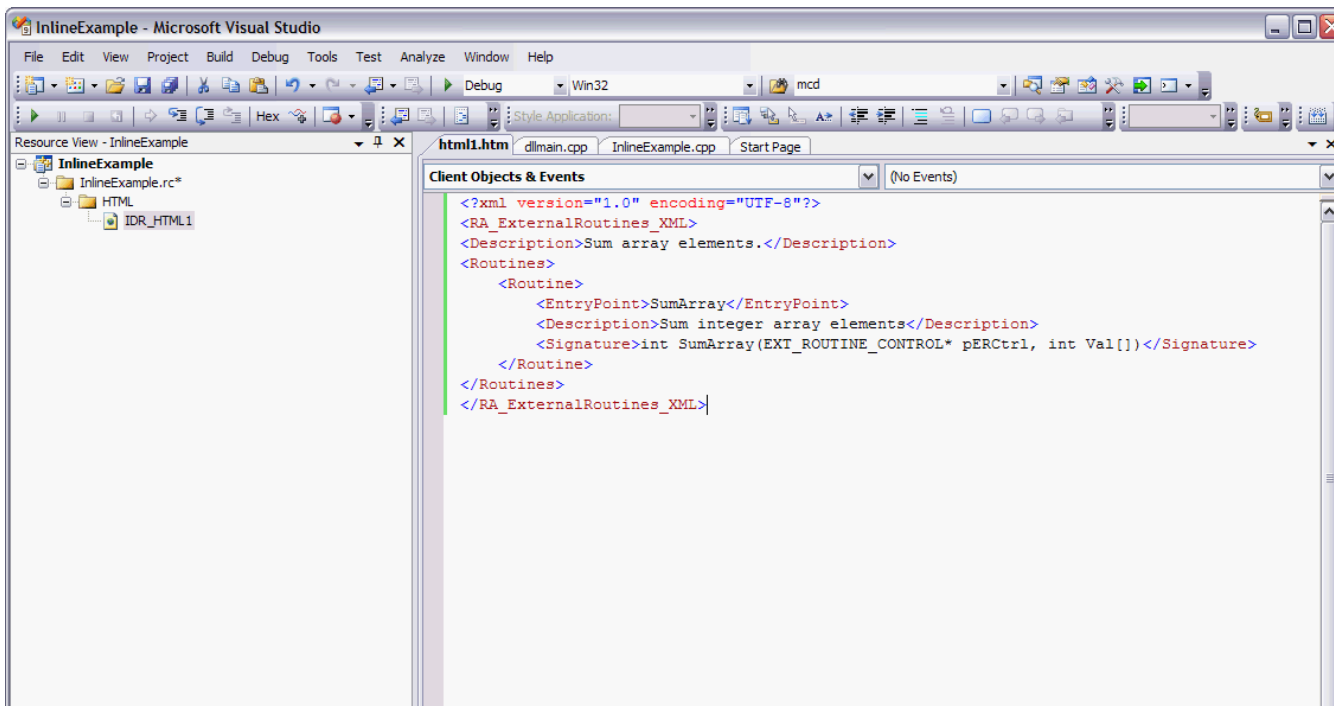

- Edit the HTML file and put in the XML descriptions of the external routines.

These tags are required.

Tag	Description
<RA_ExternalRoutines_XML>	This tag indicates that the following information is related to external routines.
<Description>	This tag documents the type of routines that are contained in the DLL. The information provided here is completely up to the developer. This information is not used by the Logix Designer application and is not displayed to the user. This information is for internal documentation purposes only.
<Routines>	This tag indicates that the following information contains the description of the exported functions in the DLL.
<Routine>	This tag describes information that relates to one external routine. You can have more than one exported function per DLL, so you can have multiple <Routine> blocks. There is one <Routine> tag for each exported function in the DLL. Each <Routine> tag contains the following XML tags: <EntryPoint>, <Description>, and <Signature>.
<EntryPoint>	This tag contains the name of the function that is exported from the DLL. If the routine is exported by using C style exporting, then the name is the same as the name of the function. If the routine is exported by using C++ style exporting, then the name needs to match the C++ decorated name exported by the C++ compiler. Details on how to obtain the C++ decorated name are described in a later section of this document.
<Description>	This tag documents the functionality of an individual function. The information provided here is at the discretion of the developer. This description is displayed by the Logix Designer application during the mapping procedure.
<Signature>	This tag describes the interface to the routine, its parameters, and its return value. This tag is used for two purposes: to display to the user during the mapping process and to verify parameters in the JXR instruction during verification of the project in the Logix Designer application. The number of parameters and parameter types must match exactly with what the routine requires.

7. To change the ID field, choose View>Other Windows> Properties Windows.

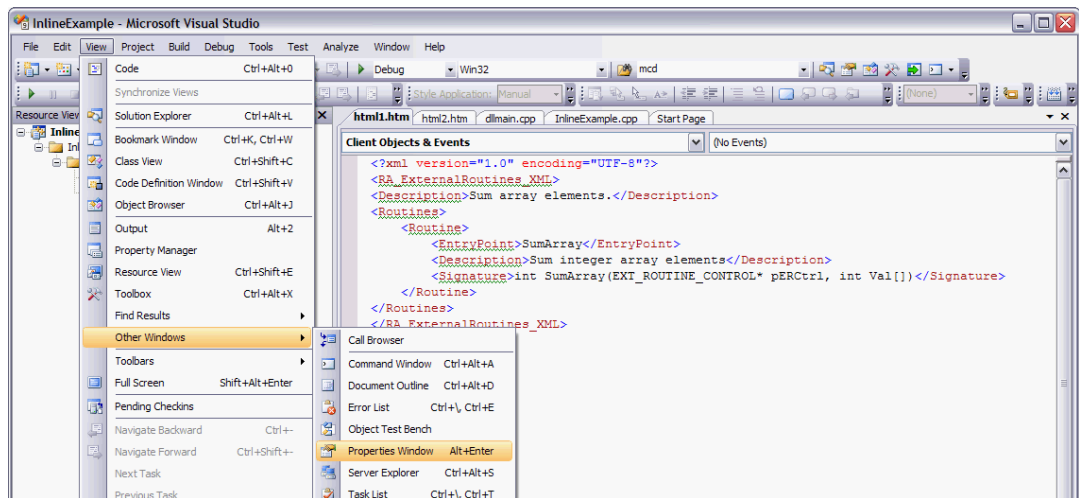

The Resource Properties dialog box appears.

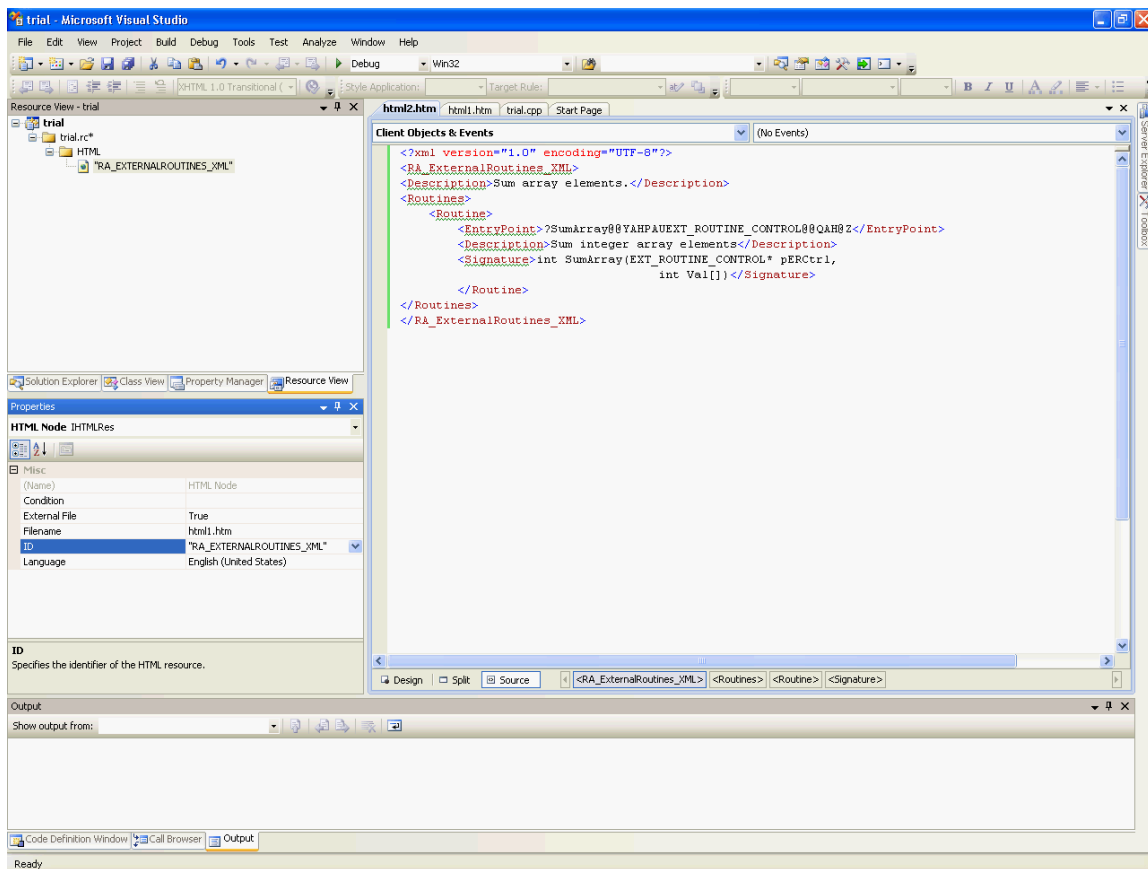

- Change the name of the resource to 'RA\_EXTERNALROUTINES\_XML.' Do this by editing the ID field of the resource properties dialog box.

---

**IMPORTANT** The quotes in the code are required.

---

- From the File menu, choose Save.

## Add Version Information to an External Routine DLL

Add version information to your DLL to keep track of your development changes. Follow these steps.

1. From the View menu, choose Resource View.

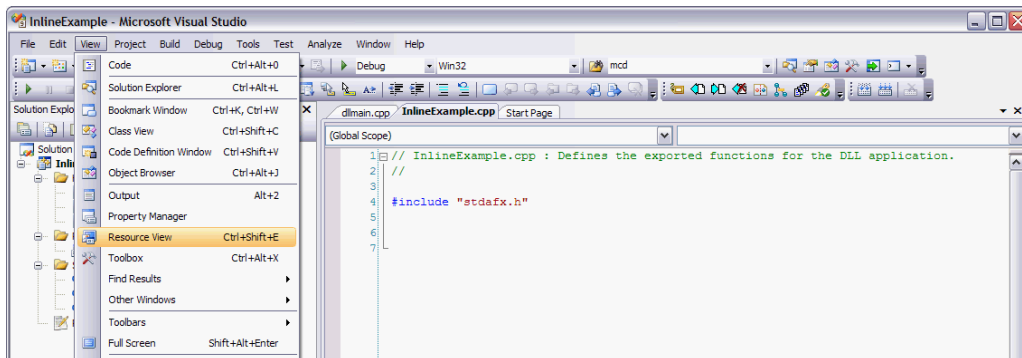

The Resource View dialog box appears.

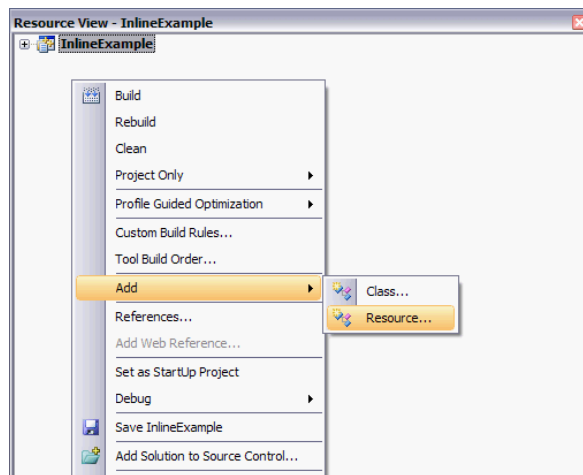

2. Right-click InlineExample and choose Add>Resource.

The Add Resource dialog box appears.

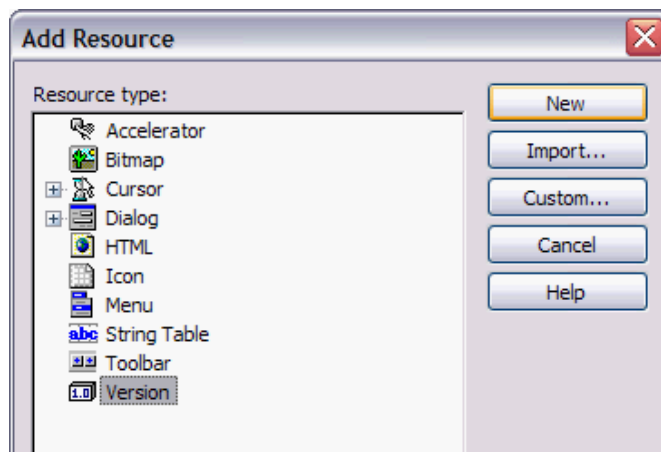

3. Select Version as the Resource type and click New.



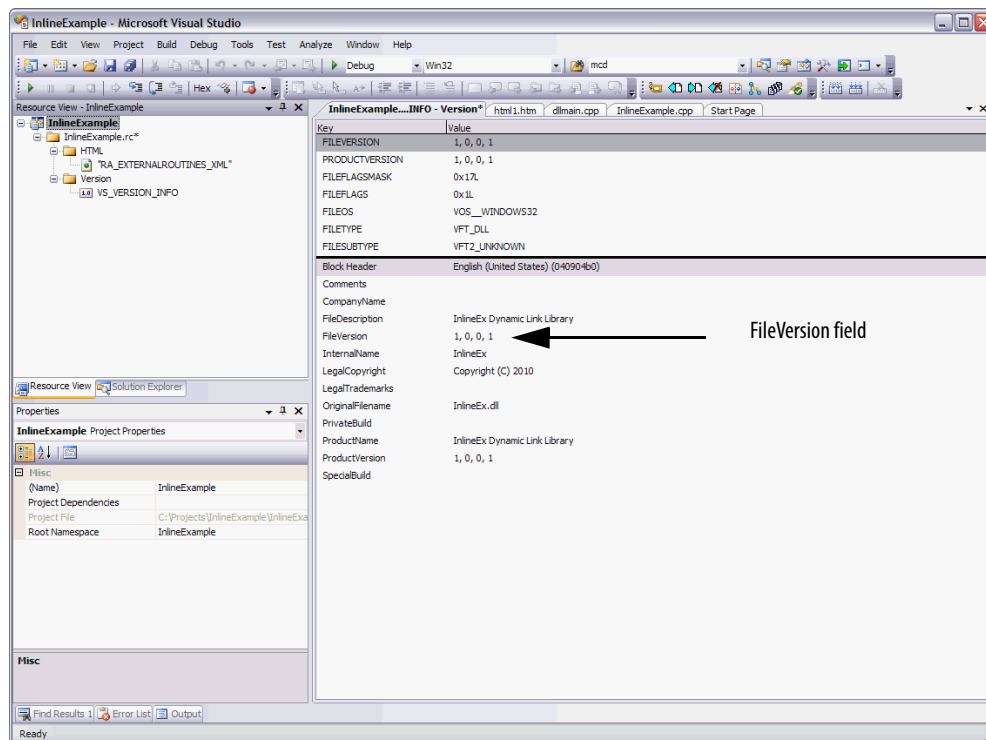

#### 4. Choose the FileVersion field.

The application uses the FileVersion field under the Block Header English (United States) to display version information for the external routine DLL. The software uses only this field; not the FILEVERSION (all capital letters) or any other FileVersion field located in any other language sections.

The FileVersion field is a string and is completely under the control of the developer. Whatever you enter in this field is what the Logix Designer application displays.

The Logix Designer application displays this version information in two places:

- On the properties/configuration screen for the external routine
- In the quick-view pane when you place the cursor on an external routine within the Controller Organizer

## Build and Download External Routines

Before you build an external routine, make sure that `RA_ExternalRoutines.h` is in the include path for the project. Then, follow these steps.

1. Build the project.
2. Map the external routines into a project.
3. Download the project to a SoftLogix controller.

The external routine DLL is downloaded as a part of the project download.

## Update an Existing External Routine

To update an existing external routine do the following.

1. Edit the source code in Visual Studio software.
2. Rebuild the project.
3. Re-map the external routines into a project.

If you re-map one function from a DLL, all of the other functions that you use from the same DLL are also re-mapped. When a DLL is re-mapped, a re-verification is done on all of the routines that reference the DLL. Routines that reference a DLL different from the one re-mapped are unaffected by this process.

4. Re-download the project to the SoftLogix controller.

The external routines must be re-mapped and the project must be re-downloaded to the controller for the changes to be made in the SoftLogix controller.

## Create Multi-threaded External Routines

The following example shows an external routine that creates threads to do the majority of the processing. Consider using this approach when the amount of time required to execute is large enough that it causes a watchdog fault in the controller. Applications that have disk I/O or, as in the following example, play \*.wav files, are created in this manner.

The following example also shows how to synchronize the threads with the controller so that they can react properly to changes of state in the controller.

## Sounds.cpp

```
// Sounds.cpp : Defines the entry point for the DLL application.

#include "stdafx.h"
#include "RA_ExternalRoutines.h"
#include <Mmsystem.h>
#include <process.h>

HANDLE          hTerminate = NULL;

// DllMain needs to create a global event which all threads need to check for.
// This event will be used to tell the threads that the DLL is being unloaded
// and that it is time to terminate.
//
// Not creating and using this event can lead to access violations in the threads which
// will cause the SoftLogix controller to terminate and display a red X across the module.

BOOL APIENTRY DllMain( HANDLE hModule,
                      DWORD  ul_reason_for_call,
                      LPVOID lpReserved
                      )
{
    switch (ul_reason_for_call)
    {
    case DLL_PROCESS_ATTACH:
        hTerminate = CreateEvent (NULL, TRUE, FALSE, NULL);
        return (TRUE);

    case DLL_PROCESS_DETACH:
        SetEvent (hTerminate);
        Sleep (50); // give threads the chance to act on termination notice.
        return (TRUE);

    case DLL_THREAD_ATTACH:
    case DLL_THREAD_DETACH:
        return (TRUE);
    }

    return (FALSE);
}

typedef enum rungStates {
    FIRST_SCAN,
    RUNG_TRUE,
    RUNG_FALSE,
    INVALID_STATE
} RUNGSTATES;

RUNGSTATES rungState = INVALID_STATE;

HANDLE          hControllerState;

void PlaySound(char * Snd)
{
    HGLOBAL hResLoad;           // handle to loaded resource
    HRSRC hRes;                // handle/ptr. to res. info. in hDLL
    LPTSTR lpResLock;          // pointer to resource data
    BOOL bRes = TRUE;
}
```

```

// By building the sound resourced into the dll and doing a load
// library on the dll we ensure that the resources are written
// down to the controller with the dll. This means that we do not
// have to worry about copying the resources to the controller on our own.
HINSTANCE MyLib = LoadLibrary("Sounds.dll");
if (MyLib == NULL)
{
    return;
}

hRes = FindResource(MyLib, Snd, "SOUNDS");
if (hRes == NULL)
{
    return;
}

hResLoad = LoadResource(MyLib, hRes);
if (hResLoad == NULL)
{
    return;
}

lpResLock = (LPTSTR)LockResource(hResLoad);
if (lpResLock == NULL)
{
    return;
}

sndPlaySound(lpResLock, SND_SYNC | SND_MEMORY);

FreeLibrary(MyLib);
}

void RungStateThread(void *p )
{
    bool    exitThread = FALSE;
    rungStates    oldRungState = rungState;
    DWORD    status;
    HANDLE    hController = p;
    HANDLE    hArrayHandles [2];

    hArrayHandles[0] = hController;
    hArrayHandles[1] = hTerminate; // used to check if thread should terminate.

    while (!exitThread)
    {
        // This example uses an arbitrary timeout of 5 seconds
        // to determine whether the controller is still in run mode.
        // If this time expires, we can assume that the controller
        // is no longer in run mode, and we can terminate this thread.

        // Note: The 5000 millisecond timeout value can be adjusted
        // to a value that fits the requirements for your specific
        // application.

        status = WaitForMultipleObjects (2, hArrayHandles, FALSE, 5000);
        switch (status)
        {
            case WAIT_OBJECT_0:

```

```

        if (oldRungState != rungState)
        {
            oldRungState = rungState;
            switch (oldRungState) {
                case FIRST_SCAN:
                    PlaySound("FIRSTSCAN");
                    break;
                case RUNG_TRUE:
                    PlaySound("RUNGTRUE");
                    break;
                case RUNG_FALSE:
                    PlaySound("RUNGFALSE");
                    break;
                default:
                    exitThread = TRUE;
            }
        }
        break;
    case WAIT_OBJECT_0 + 1:
        exitThread = TRUE;
    case WAIT_TIMEOUT:
    case WAIT_ABANDONED:
    case WAIT_FAILED:
        exitThread = TRUE;
    }
}

CloseHandle(hController);
_endthread();
}

extern "C" __declspec(dllexport) void SayRungState(EXT_ROUTINE_CONTROL * pERCtrl)
{
    pERCtrl->ctrlWord.EN = pERCtrl->ctrlWord.EnableIn;

    rungState = INVALID_STATE;

    // Only create the thread on prescan.
    if (pERCtrl->ctrlWord.ScanType == 1)
    {
        hControllerState = CreateEvent(NULL, FALSE, TRUE, NULL);
        if (hControllerState)
        {
            HANDLE hThread;

            hThread = (HANDLE) _beginthread (RungStateThread,
                                           0, // stack size
                                           hControllerState); // arglist

            if (hThread != INVALID_HANDLE_VALUE)
            {
                // The following code will set the thread's priority to the
                // same priority as the task that invoked the external routine.
                // If the thread is not performing time-critical work, then
                // it is recommended that you set its priority to
                // THREAD_PRIORITY_IDLE, i.e.
                // SetThreadPriority (hThread, THREAD_PRIORITY_IDLE);
                SetThreadPriority (hThread,
                                GetThreadPriority(GetCurrentThread()));
            }
        }
    }
}

```

```
    }
    else
    {
        if (pERCtrl->ctrlWord.FirstScan)
        {
            rungState = FIRST_SCAN;
        }
        else if (pERCtrl->ctrlWord.EnableIn)
        {
            rungState = RUNG_TRUE;
        }
        else
        {
            rungState = RUNG_FALSE;
        }

        SetEvent(hControllerState);
    }
    return;
}
```

## Thread Priorities in a Multithreaded External Routine DLL

If you use Microsoft C or C++ to develop your external routine, use only the ‘\_beginthread’ C runtime function, as shown above in the example. By using the ‘\_beginthread’ and ‘\_endthread’ calls verifies that the system resources are properly allocated by the Microsoft C runtime library.

When developing a multithreaded DLL, you must link with the multithreaded version of the C runtime library. Use the Multithreaded DLL option in your project settings for the run-time library option.

Keep in mind that the default priority assigned to a thread upon its creation is `THREAD_PRIORITY_NORMAL`. This priority level (priority level 2) is reserved for running the controller's periodic tasks. Set the priority of the newly created thread to something more appropriate so as not to interfere with the execution of periodic tasks in the controller. The example above shows how to set the thread priority to be equal to the priority of the parent thread, or `THREAD_PRIORITY_IDLE` if the thread does not perform any time-critical operations.

The following table shows the mapping between thread priorities and the controller's task priorities:

Continuous Task	<code>THREAD_PRIORITY_LOWEST</code>
Periodic Task (pri. 3)	<code>THREAD_PRIORITY_BELOW_NORMAL</code>
Periodic Task (pri. 2)	<code>THREAD_PRIORITY_NORMAL</code>
Periodic Task (pri. 1)	<code>THREAD_PRIORITY_ABOVE_NORMAL</code>

If you do not set the priority of a thread created via the “\_beginthread” runtime function to the recommended values, periodic task overlap faults or watchdog faults can occur.



**ATTENTION:** Do not set the priority of any thread to a value greater than `THREAD_PRIORITY_ABOVE_NORMAL` because it will interfere with the operation of critical controller system threads and may result in unpredictable behavior of the controller.

---

## Debug External Routines

You can debug external routines by setting up a debug session.

### Set Up the Debug Session

If you built your DLL with Program Database Symbolic Information (PDB), you must copy the PDB file into the directory where the External Routine DLL is copied during a download to the controller. This file is not copied as a part of the normal download to the SoftLogix controller.

For example, if you have a controller in slot 3 that is using an External Routine DLL called `InlineExample.dll`, copy `InlineExample.pdb` to:

`C:\Program Files\Rockwell Automation\SoftLogix 5800\data\slot03.`

The location `C:\Program Files\Rockwell Automation\SoftLogix 5800` is where the SoftLogix controller is installed. The location `'data\slot03'` is where data related to a particular instance of the controller resides. The slot directory is created as needed when a controller is inserted into the SoftLogix Chassis Monitor.



## Start a Debug Session

To debug an external routine, execute the SoftLogix controller (SoftLogix5800.exe) from the Visual Studio debugger. Create an empty project and edit the project settings.



**ATTENTION:** Do not attempt to control equipment while debugging external routines.

1. Set the debug dialog box as follows.

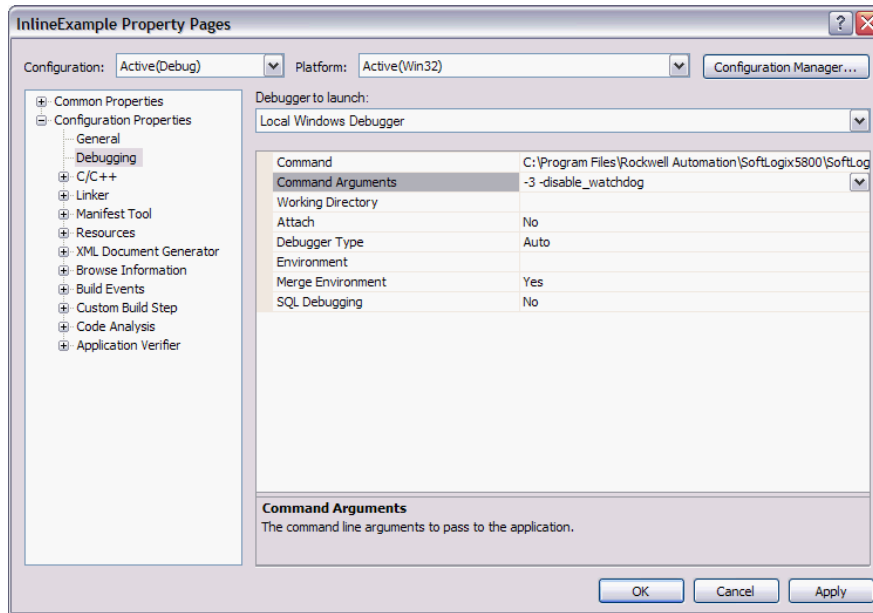

Debug Dialog Box Item	Description
Executable for debug session	C:\Program Files\Rockwell Automation\SoftLogix 5800\ SoftLogix5800.exe
Program arguments	-n -disable_watchdog Where <i>n</i> is a number that represents the slot number of the controller. Make sure to include a space between both arguments For example, -3 -disable_watchdog. The 3 flag indicates that the controller is in Slot 3. The disable_watchdog flag lets you run the controller in the debugger and it disables the watchdog so you can step through your code without faulting the controller. This flag also forces the controller to run in Test mode (transition to Run mode is disabled), which causes output modules to be set to their Program mode.

Make sure you choose the Softlogix5800.exe executable from the install path for SoftLogix 5800 controller (by default, the Rockwell Automation folder).

Be sure you disable the watchdog timeout by entering - (slot#) - disable\_watchdog (as shown above).

2. Perform a Build → Clean and then a Build → Batch Build. Verify that both Debug and Release are selected and then Rebuild All.

This should produce debug information within the DLL.

3. Copy the *external\_routine.pdb* file produced by visual studio to the SoftLogix 5800\data\slot# folder.
4. Map over the DLL file produced into the Logix Designer application project for all JXR instructions
5. Download the project to the controller and go offline
6. Remove the controller from the chassis.
7. Go back to Visual Studio and set your break points (see [Set Breakpoints in External Routine Code](#)).
8. Start the Visual Studio Project into Debug Mode by pressing F5.
9. If you watch the SoftLogix Chassis Monitor, you should see a SoftLogix controller inserted into the chassis.

Now you can step through your code in Visual Studio.

## Set Breakpoints in External Routine Code

When you download a project to the controller, this loads (or re-loads) the DLLs containing your external routines. Once the external routine DLLs are loaded, you can set breakpoints in any of the external routines.

## Data Type Support

The table defines the supported data types.

Data Type	C++ Data Type	Passing Method	Type Checking
BOOL	Bool	By reference By value	Strong
INT	Short	By reference By value	Strong
DINT	Long Int	By reference By value	Strong
SINT	Char	By reference By value	Strong
REAL	Float	By reference By value	Strong
UDT	Structure	By reference	Weak The type declaration must have the struct keyword.
Others	Foid*	By reference	Weak All nonliterals are accepted.

The Logix Designer application arrays pass type checking if the external routine parameter is declared `void *` or uses `'arrayType arrayName[ ]'` convention. Arrays are passed by reference. Their element size and number are passed to an external routine via a control structure that can be checked at run time if desired by the external routine developer.

## ARRAY Example

### C Declaration

```
extern "C" __declspec(dllexport) float SumArray(EXT_ROUTINE_CONTROL* pERCtrl,
                                               float Val[])
```

### XML Declaration

```
<Routine>
  <EntryPoint>SumArray</EntryPoint>
  <Description>Sum floating point array elements</Description>
  <Signature>float SumArray(EXT_ROUTINE_CONTROL* pERCtrl,
                            float Val[])</Signature>
</Routine>
```

### Software Declaration

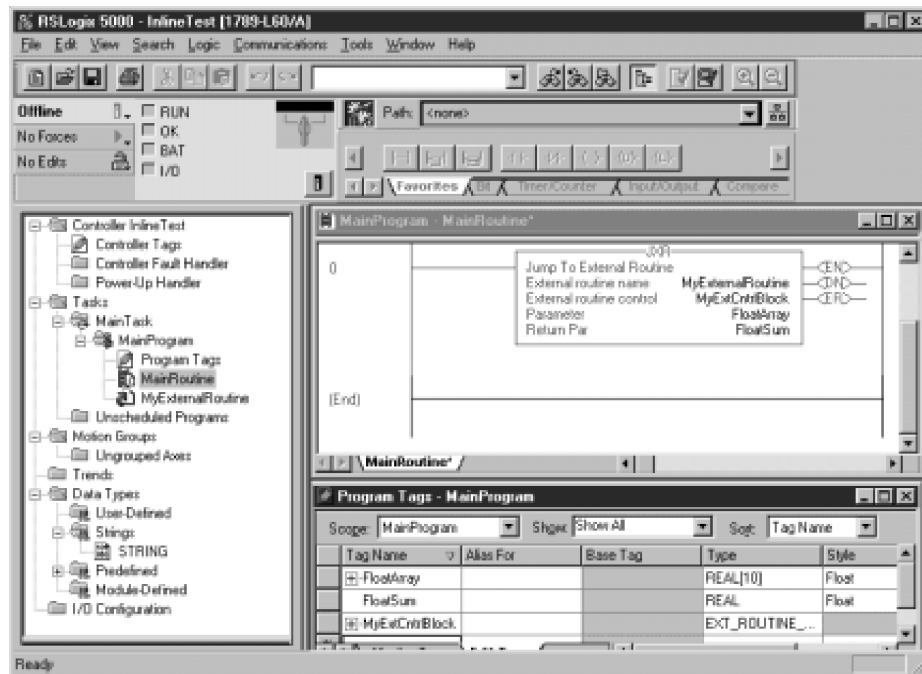

## INTEGER Example

### C Declaration

```
extern "C" __declspec(dllexport) int SomeCalculation(EXT_ROUTINE_CONTROL* pERCtrl,
                                                    int Val)
```

### XML Declaration

```
<Routine>
  <EntryPoint> SomeCalculation </EntryPoint>
  <Description>Do an important calculation</Description>
  <Signature>int SomeCalculation (EXT_ROUTINE_CONTROL* pERCtrl,
                                  int Val)</Signature>
</Routine>
```

### Software Declaration

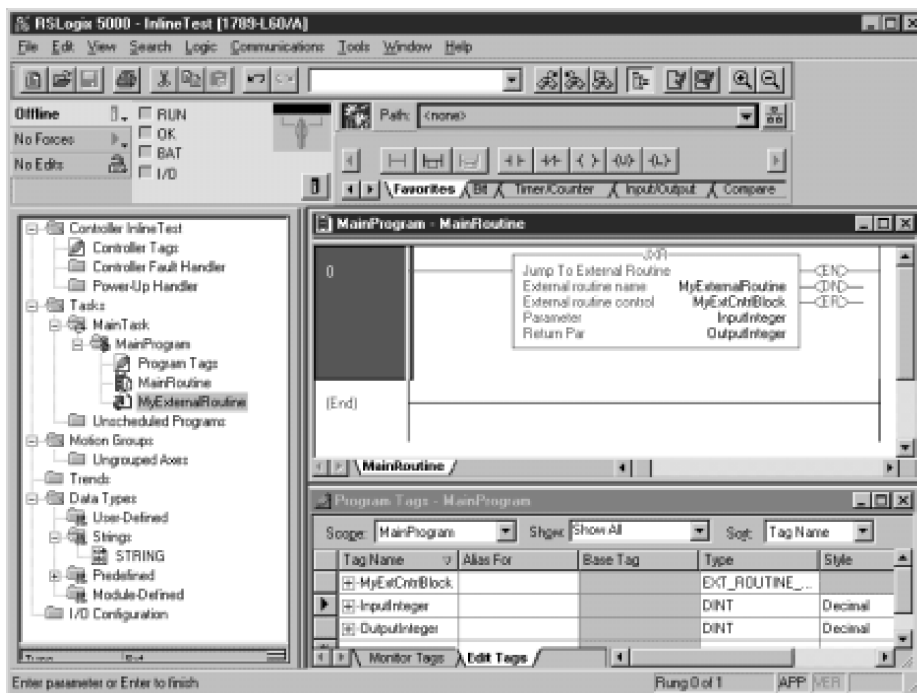

## STRUCTURE Example

### *C Declaration*

```
struct MyStruct
{
    // Structure with four integers
    int n1;
    int n2;
    int n3;
    int sum;
};

extern "C" __declspec(dllexport) int uvUDT(EXT_ROUTINE_CONTROL* pERCtrl,
                                           MyStruct* pMS)
```

### *XML Declaration*

```
<Routine>
  <EntryPoint>uvUDT</EntryPoint>
  <Description>This function accepts a pointer to a UDT</Description>
  <Signature>int uvUDT(EXT_ROUTINE_CONTROL* pERCtrl,
                       struct MyStruct* pMS)</Signature>
</Routine>
```

### *Software Declaration*

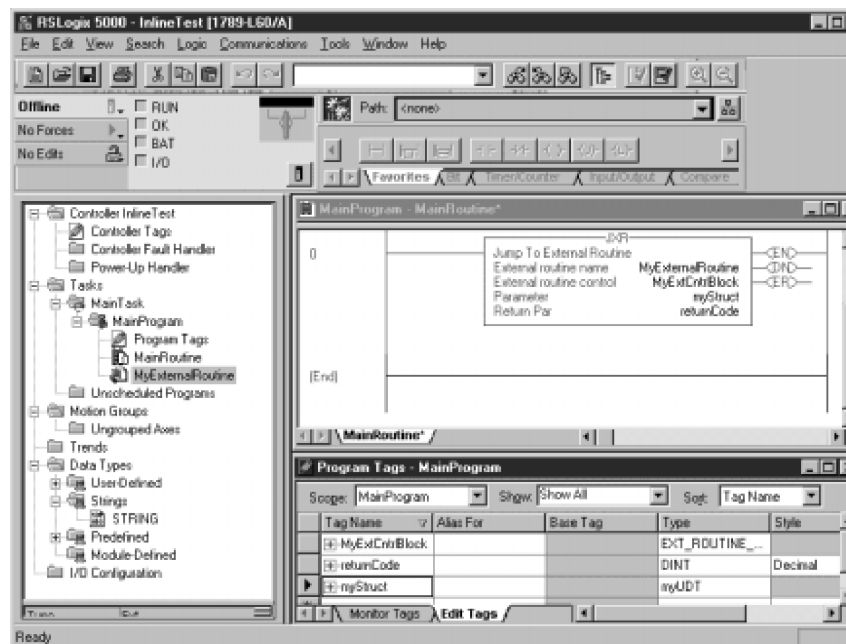

## STRING Example

### C Declaration

```
struct RA_String
{
    unsigned long Len;
    char Data[82];
};

extern "C" __declspec(dllexport) void StringFunc(EXT_ROUTINE_CONTROL* pERCtrl,
        RA_String* pInRA_String, RA_String* pOutRA_String)
```

### XML Declaration

```
<Routine>
  <EntryPoint>StringFunc</EntryPoint>
  <Description>This function accepts two strings. </Description>
  <Signature>void StringFunc(EXT_ROUTINE_CONTROL* pERCtrl,
        struct RA_String* pIn, struct RA_String* pOut)</Signature>
</Routine>
```

### Software Declaration

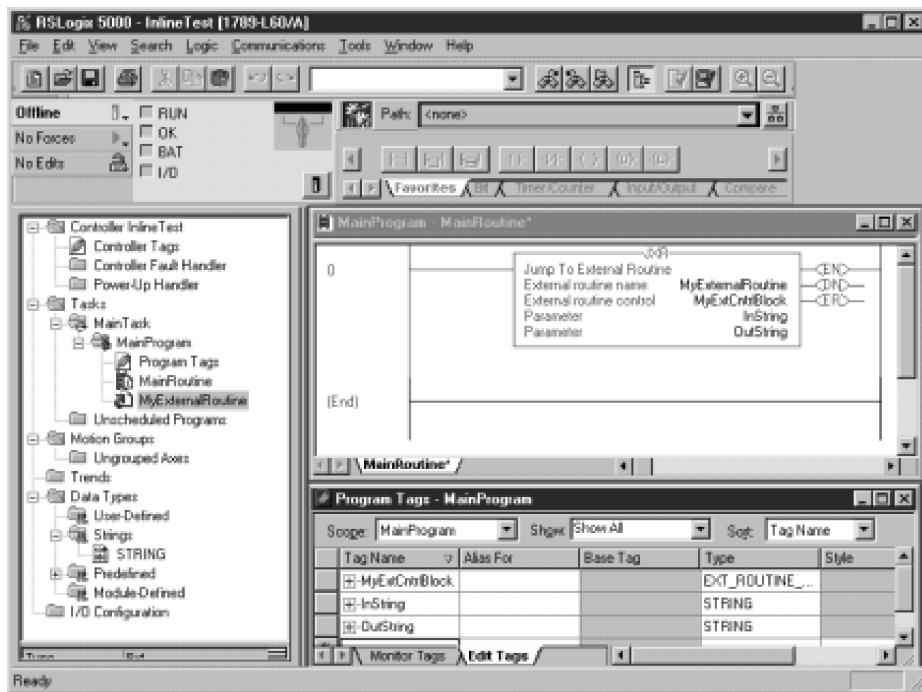

## Packing in Structures

Take care when designing user-defined structures that are shared between the SoftLogix controller and external routines. The packing mechanisms vary between the Visual Studio compiler and the Logix Designer compiler. This table and guidelines help illustrate this situation.

Logix Designer Application Structure Storage			
Member Data Type	Alignment	Packing	Storage
Consecutive BOOLs	4 byte boundaries	bit packed across storage	$((N-1 \text{ bits} / 32) + 1) * 4 \text{ bytes}$
Array <BOOL>	4 byte boundaries	bit packed across storage	$((N-1 \text{ bits} / 32) + 1) * 4 \text{ bytes}$
BOOL	1 byte boundaries	1 per byte of storage	1 byte
SINT	1 byte boundaries	1 per byte of storage	1 byte
INT	2 byte boundaries	1 per 2 bytes of storage	2 bytes
DINT	4 byte boundaries	1 per 4 bytes of storage	4 bytes
REAL	4 byte boundaries	1 per 4 bytes of storage	4 bytes
Array <nonBOOL>	4 byte boundaries	1 per N bytes of storage	$(\text{eleSize} * \text{eleCount}) \text{ bytes}$
<StructureT> (such as, UDT)	4 byte boundaries	1 per N bytes of storage	$\text{Ceiling}(\text{sizeof}(\text{StructureT}) / 4) * 4 \text{ bytes}$

- Aggregates like arrays and structures start on 4-byte boundaries.
- Consecutive BOOLs are bit-packed, as are boolean arrays.
- SINTs and BOOLs are one-byte aligned unless noted above.
- INT is 2-byte aligned.
- REAL and DINT are 4-byte aligned.
- Gaps of one or more bytes may exist between items.

This table shows the Microsoft packing for Visual Studio software, version 6.0. If you are not using this version of Visual Studio software, consult your documentation for appropriate packing information.

Microsoft Win32 Structure Storage (default n=8)			
Member Data Type	Alignment	Packing	Storage
BOOL	Min(1,n) byte boundaries	1 per byte of storage	1 byte
Char	Min(1,n) byte boundaries	1 per byte of storage	1 byte
Short	Min(2,n) byte boundaries	1 per 2 bytes of storage	2 bytes
Int	Min(4,n) byte boundaries	1 per 4 bytes of storage	4 bytes
Long	Min(4,n) byte boundaries	1 per 4 bytes of storage	4 bytes
Float	Min(4,n) byte boundaries	1 per 4 bytes of storage	4 bytes
Array <AnyT>	Min(eleAlignment,n) byte boundaries	1 per N bytes of storage	$(\text{eleSize} * \text{eleCount}) \text{ bytes}$
<StructureT> (such as, struct)	Min(largestOfMember,n) byte boundaries	1 per N bytes of storage	$\text{Sizeof}(\text{StructureT}) \text{ bytes}$

## Parameter Type Checking

Logix Designer Application Data Type	Formal Parameter Enumeration	Allowed C Language Types (XML)
Literal integer value (such as 121)	IntegerValue	Char, short, int, long, bool
DINT	IntegerAddress IntegerValue VoidAddress	Int*, long* Int, long Void*
INT	IntegerAddress IntegerValue VoidAddress	Short* Short Void*
SINT	IntegerAddress IntegerValue VoidAddress	Char* Char Void*
Literal floating point values (such as 12.345)	FloatingPointValue	Float
REAL	FloatingPointAddress FloatingPointValue VoidAddress	Float* Float Void*
BOOL	IntegerAddress IntegerValue VoidAddress	Bool* Bool Void*
Literal BOOL	IntegerValue	Bool
UDT	StructureAddress VoidAddress	Struct AnyStructT* s Void*
Arrays	ArrayAddress  VoidAddress	Char var[], short var[], int var[], long var[], Bool var[], float var[], struct AnyStructT var[] Void*

## Return Parameter

Only floating point and integer values can be returned from the external routine. You cannot pass a pointer to a memory location as the return parameter. This is enforced to maintain the integrity of the controller. Note that all memory that is referenced by both the controller and an external routine must have been allocated by the controller.

Logix Designer Application Data Type	Formal Parameter Enumeration	Allowed C language Types (in XML)
DINT	IntegerValue	Int Long
INT	IntegerValue	Short
SINT	IntegerValue	Char
REAL	FloatingPointValue	Float
BOOL	IntegerValue	Bool



## Export Functions by Using C++ Export Style

If you export your external routine functions by using the C++ export style, make sure that the EntryPoint value in your XML resource exactly matches the C++ decorated name that is exported by your C++ compiler.

Visual Studio software includes a tool (dumpbin.exe) that you can use to obtain the C++ decorated name from your DLL file. The dumpbin.exe tool is installed as part of Visual Studio product. The examples below show how to use this tool.

### InlineExample.h

```
// Exported Functions:
__declspec(dllimport) int SumArray(EXT_ROUTINE_CONTROL* pERCtrl,
                                   int Val[]);
```

### InlineExample.cpp

```
__declspec(dllexport) int SumArray(EXT_ROUTINE_CONTROL* pERCtrl,
                                   int Val[])
{
    // body of function.
```

### Run dumpbin.exe

Run dumpbin.exe with the /exports flag set to display the decorated names for all of the exported routines. The following is the output running dumpbin /exports on a C++ DLL.

For example, entering this command:

```
Dumpbin.exe /exports InlineExample.dll
```

displays this output information.

```
Microsoft (R) COFF Binary File Dumper Version 6.20.8700
Copyright (C) Microsoft Corp 1992-2000. All rights reserved.
```

```
Dump of file InlineExample.dll
```

```
File Type: DLL
```

```
Section contains the following exports for InlineExample.dll
```

```
    0 characteristics
3BA9F7A0 time date stamp Thu Sep 20 10:05:20 2001
    0.00 version
    1 ordinal base
    1 number of functions
    1 number of names
```

```
ordinal hint RVA      name
```

```
1      0 0000100A ?SumArray@@YAHPAUEXT_ROUTINE_CONTROL@@@QAH@Z
```

## Summary

```
4000 .data
1000 .idata
2000 .rdata
2000 .reloc
1000 .rsrc
28000 .text
```

## Edit XML Resource

Change the <EntryPoint> tag to be the decorated name (found when you ran dumpbin.exe). The XML EntryPoint name must EXACTLY match the decorated named displayed by the dumpbin.exe utility.

```
<?xml version="1.0" encoding="UTF-8"?>
<RA_ExternalRoutines_XML>
<Description>Sum array elements.</Description>
<Routines>
  <Routine>
    <EntryPoint>?SumArray@@YAHPAUEXT_ROUTINE_CONTROL@@QAH@Z</EntryPoint>
    <Description>Sum integer array elements</Description>
    <Signature>int SumArray(EXT_ROUTINE_CONTROL* pERCtrl,
                          int Val[])</Signature>
  </Routine>
</Routines>
</RA_ExternalRoutines_XML>
```

## Other Considerations

Consider these suggestions for your external routines.

### Pass Tags by Reference

You can pass tags by reference in a synchronous, single-threaded routine. You should not pass these memory addresses to another thread or process because it is possible for the originating tag to be deleted. Then, the reference to the originating tag in the thread or process becomes invalid and causes an access violation.

### External Routine DLL that Uses Other DLLs

If you create an external routine DLL that uses other DLLs, make sure that the additional DLL files are accessible to the SoftLogix engine at runtime. For example, assume external routine MyER.DLL uses another file called MyAdditionalFile.DLL. The Logix Designer application copies MyER.DLL into the project area and downloads MyER.DLL to the appropriate controller slot during download. However, the Logix Designer application does not copy or download MyAdditionalFile.DLL.

To make MyAdditionalFile.DLL available on the target machine, put the MyAdditionalFile.DLL file into the Windows system32 directory on the target machine. This makes sure that the file is available when needed. Otherwise, when the controller attempts to perform the Windows LoadLibrary call for MyER.DLL it will fail because the MyAdditionalFile.DLL cannot be found.

As a better solution, statically link any additional DLL files that are needed right into the external routine DLL. This leaves only one file and the Logix Designer application takes care of copying the DLL to the correct places.

**Notes:**

## Program Windows Events to Monitor and Change Controller Execution

Topic	Page
Use Outbound Events	149
Configure Windows Events to Launch Tasks within the SoftLogix Controller	153
Programmatically Saving the Controller	158

This chapter discusses how to program Windows events to control and monitor execution of the SoftLogix controller. There are different ways to programmatically use Windows events to monitor and change SoftLogix controller execution.

### Use Outbound Events

Use outbound events in asynchronous external routines to detect a change in the mode of a controller, allowing the external routine to start and stop asynchronous code appropriately.

Use the standard Windows 'wait' functions to test or wait for these events. Replace the 'xx' with the 2-digit slot number where the controller resides. For example, if you want to detect if the controller in slot 4 is in Run mode, check the SOFTLOGIX\_04\_RUN event.

Windows Event	Description
SOFTLOGIX_XXX_STARTUP	This event is set after the controller in slot XXX completes its power-up sequence. This event is reset when the controller is removed from the chassis or is shut down by the Windows operating system.
SOFTLOGIX_XXX_SHUTDOWN	This event is set when the controller in slot XXX is removed from the chassis or is shut down by the Windows operating system. This event is reset otherwise.
SOFTLOGIX_XXX_MODE_CHANGE	This event is set whenever the controller in slot XXX changes mode. This event is created as an automatic reset event.
SOFTLOGIX_XXX_PROGRAM	This event is set when the controller in slot XXX is in Program mode. This event is reset when the controller in slot XXX is not in Program mode.
SOFTLOGIX_XXX_RUN	This event is set when the controller in slot XXX is in Run mode. This event is reset when the controller in slot XXX is not in Run mode.
SOFTLOGIX_XXX_TEST	This event is set when the controller in slot XXX is in Test mode. This event is reset when the controller in slot XXX is not in Test mode.
SOFTLOGIX_XXX_FAULT	This event is set when the controller in slot XXX is faulted. This event is reset when the controller in slot XXX is not faulted.

## Programming Example: Outbound Events

This example monitors a controller for mode changes and displays the controller mode whenever a change occurs.

```

/*****
**
** SOFTLOGIX 5800 OUTBOUND EVENTS EXAMPLE CODE
** COPYRIGHT (c) 2003 ALLEN-BRADLEY COMPANY, L.L.C.
**
** All rights reserved, except as specifically licensed in writing.
** The following work constitutes example program code and is intended
** merely to illustrate useful programming techniques. The user is
** responsible for applying the code correctly. The code is provided
** AS IS without warranty and is in no way guaranteed to be error-free.
*****/

/*****
*
* FILE: OutBoundEventExample.cpp
*
* FULL DESC:
*
* This is an example command mode application that will indicate when
* a SoftLogix5800 controller changes modes. It uses the new Outbound
* Event support that is being introduced with version 12 of the
* SoftLogix5800 product.
*
* It should be compiled using the Microsoft Visual Studio compiler.
* You can use the following steps to compile and run this example.
*
* 1) Open a Windows command prompt window by choosing
* Start->Run, and entering cmd for the command line.
* 2) Make sure that the Microsoft Visual Studio compiler bin
* directory is in your path.
* 3) Execute the compiler using the following command
* cl OutBoundEventExample.cpp
* 4) Run the resultant executable using the following command
* OutBoundEventExample 3
* The 3 in the example above indicates the slot number for
* the controller for which you want to monitor mode changes.
*
* This example code waits for the controller mode change event,
* and after receiving the mode change event, checks the controller
* mode events to determine and display the new controller mode.
*
* Copyright Allen-Bradley Company, Inc. 2003
*
*****/
#include <stdio.h>
#include <windows.h>
#include <tchar.h>

// Define event handle variables
HANDLE hModeChange = 0;
HANDLE hProgramMode = 0;
HANDLE hRunMode = 0;
HANDLE hTestMode = 0;
HANDLE hFaultMode = 0;

```

```

// Use strings to define the event names in which we are interested
// The user will pass in the slot number via the command line
TCHAR sa_mode_change_event_fmt[] = _T("SOFTLOGIX_%02d_MODE_CHANGE");
TCHAR sa_program_event_fmt[]     = _T("SOFTLOGIX_%02d_PROGRAM");
TCHAR sa_run_event_fmt[]         = _T("SOFTLOGIX_%02d_RUN");
TCHAR sa_test_event_fmt[]        = _T("SOFTLOGIX_%02d_TEST");
TCHAR sa_fault_event_fmt[]       = _T("SOFTLOGIX_%02d_FAULT");

int main(int argc, char *argv[])
{
    int slot = 0;
    DWORD status = 0;
    TCHAR eventname[_MAX_PATH];
    // We will keep the mode event handles in an array for the WaitForMultipleObjects call
    HANDLE EventArray[4];
    HANDLE *events = &EventArray[0];
    int numevents = 0;

    // Make sure a slot number is passed in on the command line
    argc--, argv++;
    if (argc != 1)
    {
        _tprintf(_T("You must enter a slot number on the command line.\n"));
        fflush(stdout);
        return 1;
    }

    slot = atoi(*argv);
    (void) GetLastError();

    // Create the mode change event. Note: it must be created as auto reset.
    _stprintf(eventname, sa_mode_change_event_fmt, slot);
    hModeChange = CreateEvent (NULL, FALSE, FALSE, eventname);
    if (hModeChange == NULL)
    {
        _tprintf(_T("Bad mode change handle\n"));
        _tprintf(_T("GetLastError() = %d\n"), GetLastError());
        return 1;
    }

    // Create the program mode event. Note: it must be created as manual reset.
    _stprintf(eventname, sa_program_event_fmt, slot);
    hProgramMode = CreateEvent (NULL, TRUE, FALSE, eventname);
    if (hProgramMode == NULL)
    {
        _tprintf(_T("Bad program mode event handle\n"));
        _tprintf(_T("GetLastError() = %d\n"), GetLastError());
        return 1;
    }
    else
    {
        // Add the program mode event to the event array
        EventArray[numevents] = hProgramMode;
        numevents++;
    }

    // Create the run mode event. Note: it must be created as manual reset.
    _stprintf(eventname, sa_run_event_fmt, slot);
    hRunMode = CreateEvent (NULL, TRUE, FALSE, eventname);
    if (hRunMode == NULL)

```

```

{
    _tprintf(_T("Bad run mode event handle\n"));
    _tprintf(_T("GetLastError() = %d\n"), GetLastError());
    return 1;
}
else
{
    // Add the run mode event to the event array
    EventArray[numevents] = hRunMode;
    numevents++;
}

// Create the test mode event. Note: it must be created as manual reset.
_stprintf(eventname, sa_test_event_fmt, slot);
hTestMode = CreateEvent (NULL, TRUE, FALSE, eventname);
if (hTestMode == NULL)
{
    _tprintf(_T("Bad test mode event handle\n"));
    _tprintf(_T("GetLastError() = %d\n"), GetLastError());
    return 1;
}
else
{
    // Add the test mode event to the event array
    EventArray[numevents] = hTestMode;
    numevents++;
}

// Create the fault mode event. Note: it must be created as manual reset.
_stprintf(eventname, sa_fault_event_fmt, slot);
hFaultMode = CreateEvent (NULL, TRUE, FALSE, eventname);
if (hFaultMode == NULL)
{
    _tprintf(_T("Bad fault mode event handle\n"));
    _tprintf(_T("GetLastError() = %d\n"), GetLastError());
    return 1;
}
else
{
    // Add the fault mode event to the event array
    EventArray[numevents] = hFaultMode;
    numevents++;
}

// We are now ready to start waiting for mode changes!
_tprintf(_T("Ready\n"));
fflush(stdout);

// Loop forever, waiting for mode changes. The user must perform a control-c to
// stop the application
while (1)
{
    // First we wait for the single mode change event. The mode change event is an
    // automatic reset event that is set by the SoftLogix controller every time the
    // controller is changing modes. Once the mode change event is set, we need to
    // check the state of the actual mode events.
    status = WaitForSingleObject(hModeChange, INFINITE);
    switch (status)
    {
        case WAIT_OBJECT_0:

```



```

        _tprintf(_T("Mode change occurred: "));
        fflush(stdout);
        break;
    }

    // A mode change occurred. Now we have to check to determine the new controller mode.
    // This is done by performing a WaitForMultipleObjects on the mode event handles.
    // These events are manual reset events that are controlled by the SoftLogix
    // controller.
    // Only one of these events can be set at any given time.
    // Log a message to the screen indicating the new controller mode, and then go back
    // to waiting for the mode change event above.
    status = WaitForMultipleObjects(numevents, EventArray, FALSE, INFINITE);
    switch (status)
    {
        case WAIT_OBJECT_0:
            _tprintf(_T("now in program mode\n"));
            fflush(stdout);
            break;
        case WAIT_OBJECT_0+1:
            _tprintf(_T("now in run mode\n"));
            fflush(stdout);
            break;
        case WAIT_OBJECT_0+2:
            _tprintf(_T("now in test mode\n"));
            fflush(stdout);
            break;
        case WAIT_OBJECT_0+3:
            _tprintf(_T("now in fault mode\n"));
            fflush(stdout);
            break;
    }
}
return 0;
}

```

## Configure Windows Events to Launch Tasks within the SoftLogix Controller

Windows event tasks are functionality associated with Microsoft's Windows 2000 and Windows XP operating systems. Applications outside of the Logix Designer application (Visual Basic, RSVIEW, Custom C applications, external routines, and so forth) can cause a task within the SoftLogix5800 controller to execute.

### Configure a Windows-event Task in the Controller

In the SoftLogix project, we will create a task and configure the trigger as a Windows event on the controller. Follow these steps.

1. Launch the Logix Designer application.
2. Open the controller1 project we created previously.
3. In the Controller Organizer, right-click Tasks folder and choose New Task.

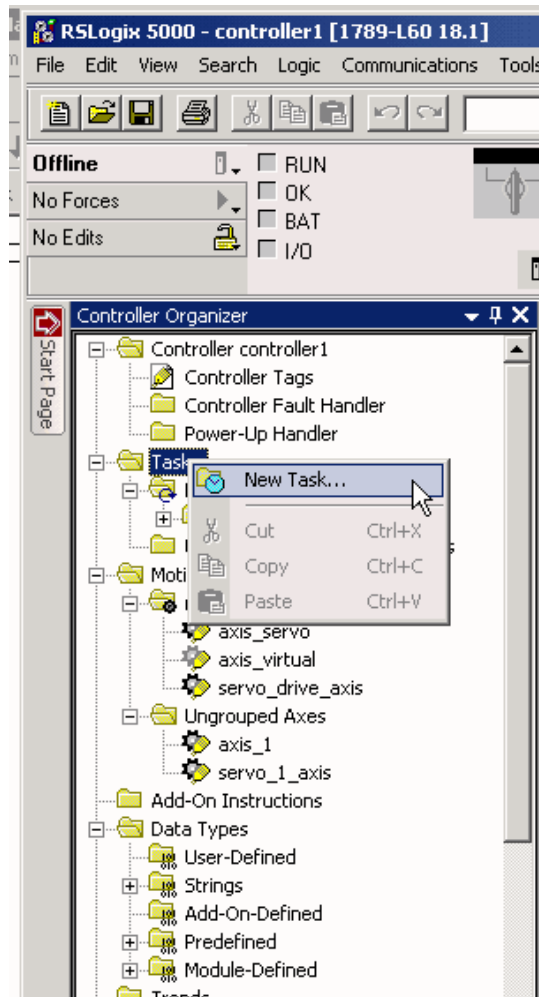

The New Task dialog box appears.

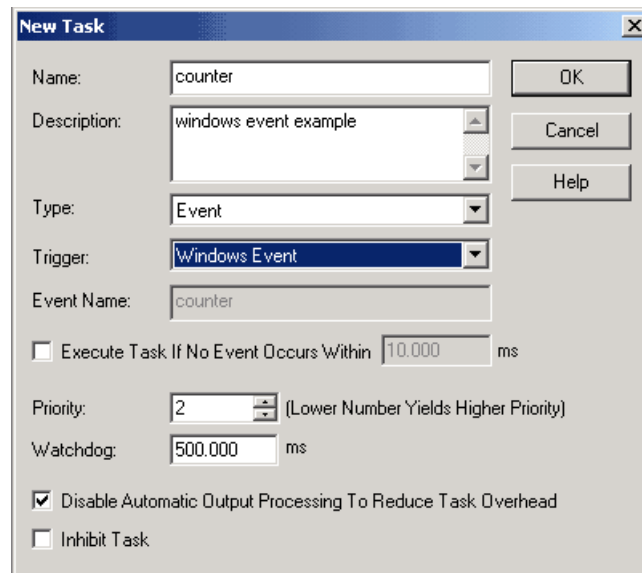

4. Type the information in the fields specific to the task.

Field	Description
Name	Type a task name.
Description	Type a description for the task.
Type pull-down menu	Choose the Event type.
Trigger pull-down menu	Choose the action that will trigger the task's execution.
Execute Task If No Event Occurs Within	Check the box if you want to allow the task to execute if the timeout period expires before an event triggers the task.
Priority	Type the priority level for the task.
Watchdog field	Type the value in milliseconds for the watchdog timer. If a watchdog timer expires, a Major fault occurs.
Disable Automatic Output Processing to Reduce Task Overhead	Click the checkbox if you want to prevent the external output modules to be updated to the controller's data table values at the end of the task scan.
Inhibit Task	Click the checkbox if you want to prevent the controller from executing this task. If the checkbox is checked, the task still is prescanned. If the task is then enabled when the controller is already in Run mode, the task is not rescanned again. This feature can be useful to test, diagnose, or start up your project.

5. Click OK.

The task appears in the Controller Organizer under the Tasks folder. Tasks are listed in alphabetical order.

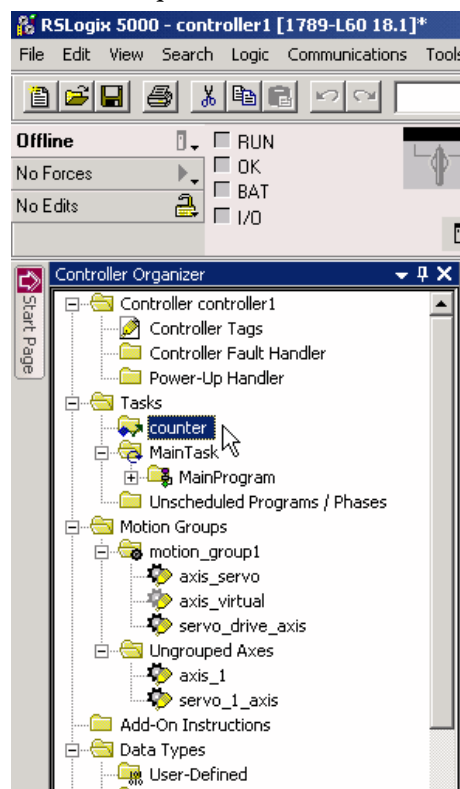

For more detailed information on planning specific types of event tasks, see the Logix5000 Controllers Common Procedures Programming Manual, publication [1756-PM001](#).

## Trigger a Controller Task from a Windows Application

In your application, such as Visual Basic or FactoryTalk software, use standard Windows API functions to open and set the Windows event in the controller.

Make sure you do the following:

- Name the Windows-event task in the controller with the same name as the Windows event in the external application.
- Open or create the Windows event in the external application as an 'automatic reset' event, otherwise the task within the controller executes continuously once the Windows event is set.
- Use a CreateEvent call to create the Windows event; use a SetEvent call to signal the Windows event.

### Programming Example: Windows Event

This example, a Visual Basic application, uses Windows events to communicate to a SoftLogix controller. The application passes data via a memory-mapped file by using the Win32 standard library.

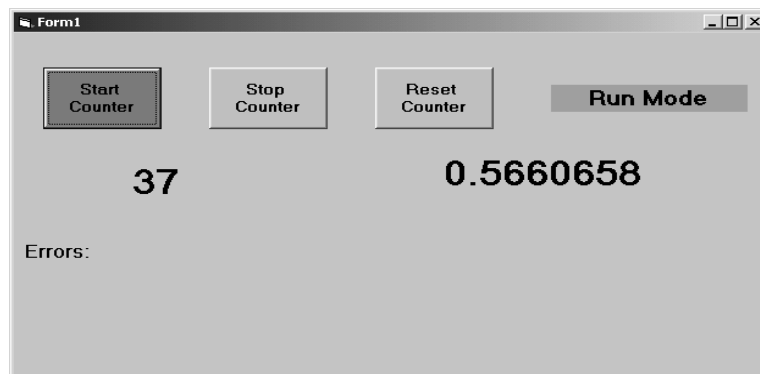

The following example code shows how you can create the public declarations:

```
Public Declare Function CreateEvent Lib "kernel32" Alias "CreateEventA" _
(lpEventAttributes As Any, ByVal bManualReset As Long, _
ByVal bInitialState As Long, ByVal lpName As String) As Long

Public Declare Function SetEvent Lib "kernel32" (ByVal hEvent As Long) As Long
```

The following example code shows how you can use the CreateEvent and SetEvent calls. This example uses the shutdown, program, and run outbound events (see [page 149](#)) before executing the Windows event named 'counter.' There is a corresponding Windows-event task in the controller named 'counter.'

```
Dim hCounter As Long
Dim hOutbound(3) As Long
Dim hCounter As Long

Private Sub Form_Load()
    Dim ErrorCodeEvent1 As Long
```

```

On Error GoTo noHandle
ErrorCodeEvent1 = 0

hOutbound(0) = CreateEvent(ByVal 0&, 0, 0, "SOFTLOGIX_01_SHUTDOWN")
ErrorCodeEvent1 = Err.LastDllError
hOutbound(1) = CreateEvent(ByVal 0&, 0, 0, "SOFTLOGIX_01_PROGRAM")
ErrorCodeEvent1 = Err.LastDllError
hOutbound(2) = CreateEvent(ByVal 0&, 0, 0, "SOFTLOGIX_01_RUN")
ErrorCodeEvent1 = Err.LastDllError
hCounter = CreateEvent(ByVal 0&, 0, 0, "Counter")
ErrorCodeEvent1 = Err.LastDllError
If ErrorCodeEvent1 <> 183 Then '183 = Event already exists which is OK
    'handle error
End If

noHandle:

End Sub

Private Sub Form_Unload(Cancel As Integer)
    CloseHandle (hCounter)
    CloseHandle (hOutbound(0))
    CloseHandle (hOutbound(1))
    CloseHandle (hOutbound(2))
End Sub

Private Sub pbCounter_Click(Index As Integer)
    Dim ErrorCodeEvent1 As Long

    SetEvent (hCounter)
    ErrorCodeEvent1 = Err.LastDllError
    If ErrorCodeEvent1 Then
        'Handle error
    End If
End Sub

Private Sub Timer1_Timer()
    Dim inMode As Long
    Dim ErrorDescription As String

    inMode = WaitForMultipleObjects(3&, hOutbound(0), False, 0)
    Select Case inMode
        Case WAIT_OBJECT_0 + 2
            Label13.BackColor = &HFF00&
            Label13.Caption = "Run Mode"
        Case WAIT_OBJECT_0 + 1
            Label13.BackColor = &HFF8080
            Label13.Caption = "Program Mode"
        Case WAIT_OBJECT_0
            Label13.BackColor = &HFF00FF
            Label13.Caption = "SHUTDOWN Mode"
        Case Else
            Label13.BackColor = &HFFFFFF
            Label13.Caption = "Other Mode"
    End Select
End Sub

```

## Programmatically Saving the Controller

From an external routine or application, you can programmatically save the current controller information (tag data values and configuration information).

A programmatic save can use these pre-defined Windows events. Replace the 'xx' with the 2-digit slot number where the controller resides.

Windows Event	Description
SOFTLOGIX_XX_KICKSAVE	This incoming event indicates that a save is to be forced in the controller in slot xx.
SOFTLOGIX_XX_SAVEPERMITTED	This outbound event indicates that a save is permitted in the controller in slot xx.
SOFTLOGIX_XX_SAVESTART	This outbound event indicates that a save has started in the controller in slot xx.
SOFTLOGIX_XX_SAVEDONE	This outbound event indicates that a save has completed in the controller in slot xx.
SOFTLOGIX_XX_SAVELOCK	This event is a handshake between multiple clients. Use this event to prevent multiple clients from attempting to start a save at the same time in the controller in slot xx.

### Programming Example: Programmatic Save of Controller

The following example codes show how you can use all of the above events to programmatically save the contents of a controller. This code uses printf statements to help track progress through the application.

```
int savenow(int slot)
{
    DWORD status;
    WCHAR eventname[_MAX_PATH];
    SECURITY_ATTRIBUTES sa;
    PSECURITY_DESCRIPTOR pSD;

    // Create a NULL DACL to allow other tasks to access the external events.
    pSD = (PSECURITY_DESCRIPTOR) LocalAlloc(LPTR, SECURITY_DESCRIPTOR_MIN_LENGTH);
    if (pSD == NULL)
        return 1;

    if (!InitializeSecurityDescriptor(pSD, SECURITY_DESCRIPTOR_REVISION))
        return 1;

    // Add a NULL DACL for full permission for all
    if (!SetSecurityDescriptorDacl(pSD, TRUE, (PACL) NULL, FALSE))
        return 1;
    sa.nLength = sizeof(sa);
    sa.lpSecurityDescriptor = pSD;
    sa.bInheritHandle = TRUE;

    // CreateEvent(security, manuallyReset, initialState, eventName);
    swprintf(eventname, sa_kicksave_event_fmt, slot);
    h_kicksaveEvent = CreateEvent (&sa, FALSE, FALSE, eventname);
    printf("h_kicksaveEvent = %d\n", h_kicksaveEvent);

    swprintf(eventname, sa_savepermitted_event_fmt, slot);
    h_savePermittedEvent = CreateEvent (&sa, TRUE, FALSE, eventname);
    printf("h_savePermittedEvent = %d\n", h_savePermittedEvent);

    swprintf(eventname, sa_savestart_event_fmt, slot);
    h_saveStartEvent = CreateEvent (&sa, TRUE, FALSE, eventname);
    printf("h_saveStartEvent = %d\n", h_saveStartEvent);
}
```

```

swprintf(eventname, sa_savedone_event_fmt, slot);
h_saveDoneEvent = CreateEvent (&sa, TRUE, FALSE, eventname);
printf("h_saveDoneEvent = %d

swprintf(eventname, sa_savelock_event_fmt, slot);
h_saveLockEvent = CreateEvent (&sa, TRUE, FALSE, eventname);
printf("h_saveLockEvent = %d

    // Yield remainder of timeslice to make it less likely that a
    // context switch will occur between the wait for lock event and
    // corresponding SetEvent().
    // If saves not permitted (download in progress) OR
    // a save is in progress
    // Explain
    // Else
    // Set lock event
    // Kick save event
    // Endif
    // Wait for save started (if desired)
    // Wait for save done (if desired)
    SwitchToThread();
    if ((WaitForSingleObject(h_savePermittedEvent, 0) != WAIT_OBJECT_0) ||
        WaitForSingleObject(h_saveLockEvent, 0) == WAIT_OBJECT_0)
    {
        printf("Save not permitted or save already running

        return 1;
    }
    else
    {
        SetEvent(h_saveLockEvent); // Save in progress
        printf("Kicking save

        SetEvent(h_kicksaveEvent);
    }

    WaitForSingleObject(h_saveStartEvent, INFINITE);
    printf("Save started

    WaitForSingleObject(h_saveDoneEvent, INFINITE);
    printf("Save complete

    return 0;
}

```

**Notes:**



## Communicate with Devices on a DeviceNet Network

Topic	Page
Configure Your System for a DeviceNet Network	162
Perform DeviceNet Test	181
DeviceNet I/O Data	188
Place the Communication Card in Run Mode	190
StatusRegister	191
Example: SoftLogix Controller and DeviceNet I/O	193

This chapter explains how to configure your SoftLogix controller on a DeviceNet network.

---

**IMPORTANT** DeviceNet modules are not currently supported in RSLogix 5000 software on 64-bit Windows operating systems.

DeviceNet is supported in SoftLogix software, version 20 or earlier.

DeviceNet is not supported for SoftLogix controllers in the Studio 5000 environment.

---

The DeviceNet network is an open standard network used for device layer networking and is responsible for these parameters:

- Node number
- Transmit size
- Receive size
- Message type
- Input data address
- Output data

For additional information about communicating with DeviceNet devices, see the DeviceNet Network Configuration User Manual, publication [DNET-UM004](#).

## Configure Your System for a DeviceNet Network

For the SoftLogix controller to operate on a DeviceNet network, you need the following:

- 1784-PCIDS DeviceNet communication card
- RSLinx software to install the DeviceNet communication driver
- RSLinx software to install the virtual backplane driver

You install the virtual backplane driver only once on the computer running the SoftLogix controller. This chapter assumes you have already installed these tools:

- Driver
- RSLogix 5000 software to configure the communication card as part of the SoftLogix system
- RSNetWorx for DeviceNet software to configure the devices on the network
- IOLinx software so that the SoftLogix controller is able to read and write I/O data

### Step 1: Install the Hardware

Make sure the 1784-PCIDS communication card is properly installed in the computer. These instructions describe how to do the following:

- Install the card in a PCI slot
- Find the instructions to install the IOLinx software
- Label the card

This section describes these steps in detail.

1. Install the card in any PCI slot within the computer.

It does not matter which PCI slot you use for the communication card. The PCI slot in the computer does not correspond to the backplane slot in the SoftLogix Chassis Monitor. You use the SoftLogix Chassis Monitor to place the communication card in a specific backplane slot.

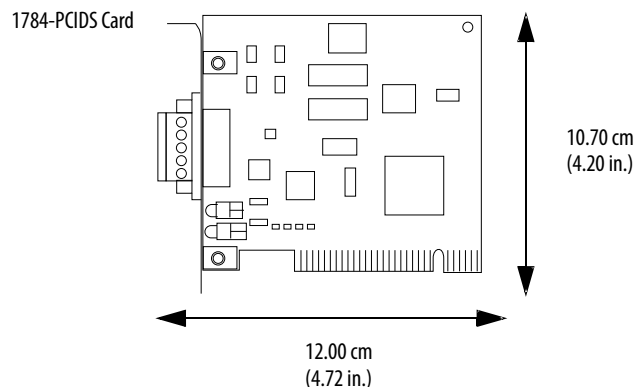

2. Install IOLinx software so the SoftLogix controller can use the 1784-PCIDS communication card to control DeviceNet I/O.

See the DeviceNet Universal PCI Scanner Card Installation Instructions, publication [1784-IN004](#).

3. Make a label to place on the mounting bracket of the card, or use a pen to write on the mounting bracket of the card.

The label should include the serial number of the card and a name you can use to identify the card from any others you might install in the computer.

---

**IMPORTANT** Remember the serial number of each communication card you install. You use the serial number to identify which card you want in a particular slot of the SoftLogix Chassis Monitor.

---

## Step 2: Create the Communication Card in the SoftLogix Chassis Monitor

Before you can connect the SoftLogix system to the DeviceNet network, you must create the 1784-PCIDS card as part of the SoftLogix Chassis Monitor.

1. In the SoftLogix Chassis Monitor, from the Slot menu, choose Create Module.
2. Click Create.

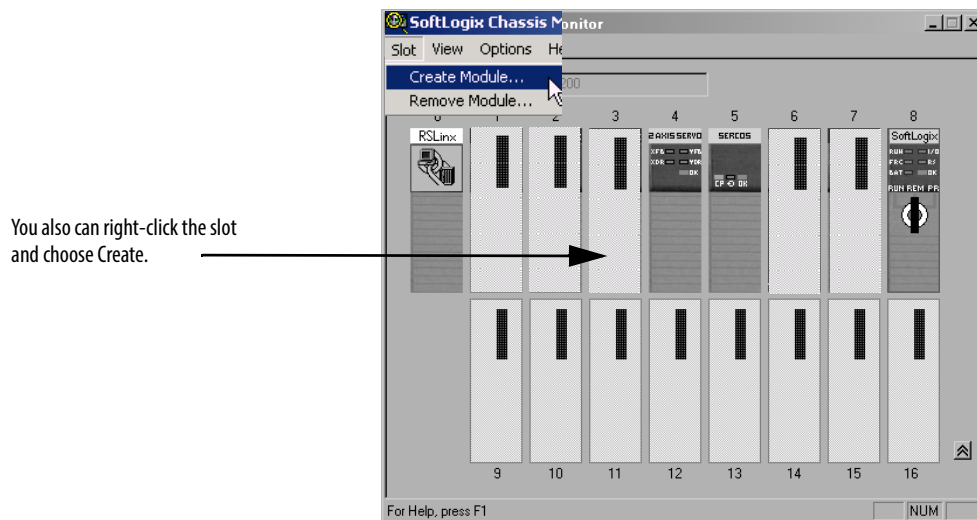

The Select Module dialog box appears.

- In the Select Module dialog box, select the 1784-PCIDS card.

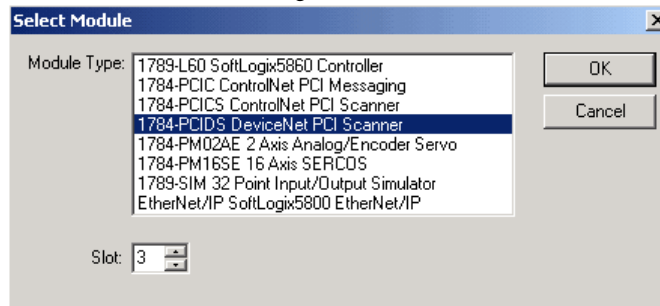

- Enter the backplane slot number.

For this example, we chose 3 as the slot number.

- Click OK.
- When the Select Device dialog box opens, choose the serial number of the 1784-PCIDS card that you want.

If you previously configured the 1784-PCIDS card that you selected by serial number, the Chassis Monitor remembers the configuration from the last time you used the card (whether in the same or different slot.)

- Click Next.

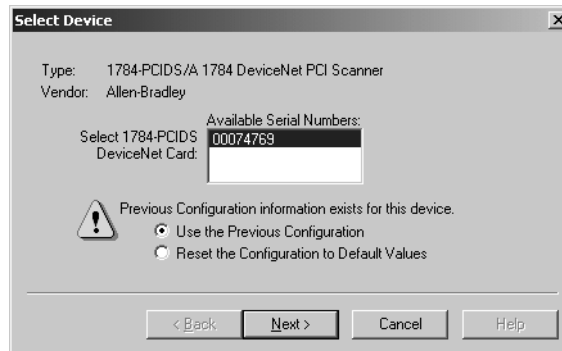

- Specify configuration settings for the 1784-PCIDS card:
  - Specify the node address (MAC ID) on the DeviceNet network.
  - Specify the Baud Rate.

- Enter the label name for the card (this is the name you wrote on the label of the card to help you identify the card from others in the same computer).

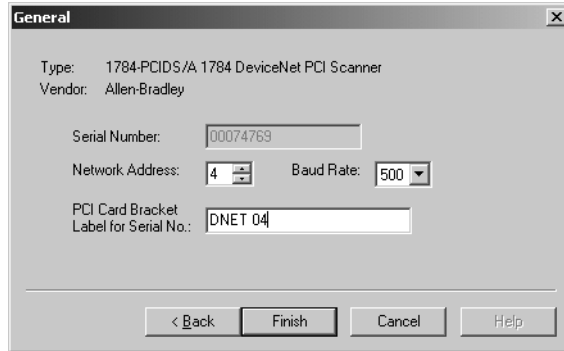

9. Click Finish.

**IMPORTANT** When you add a 1784-PCIDS card to the SoftLogix Chassis Monitor, the card must be connected to a valid, powered DeviceNet network. The baud rate you choose for the card must be the same as the baud rate for the DeviceNet network, otherwise, the card fails to insert in the SoftLogix Chassis Monitor.

For RSLogix 5000 software, version 20.00.00 or later, you can specify any slot number for the communication card, as long as the RSLinx software module is positioned in a slot other than its default 0. See [page 29](#).

This example shows the 1784-PCIDS card as a virtual module in the SoftLogix Chassis Monitor. The status indicators on the virtual monitor emulate a 1756-DNB communication module.

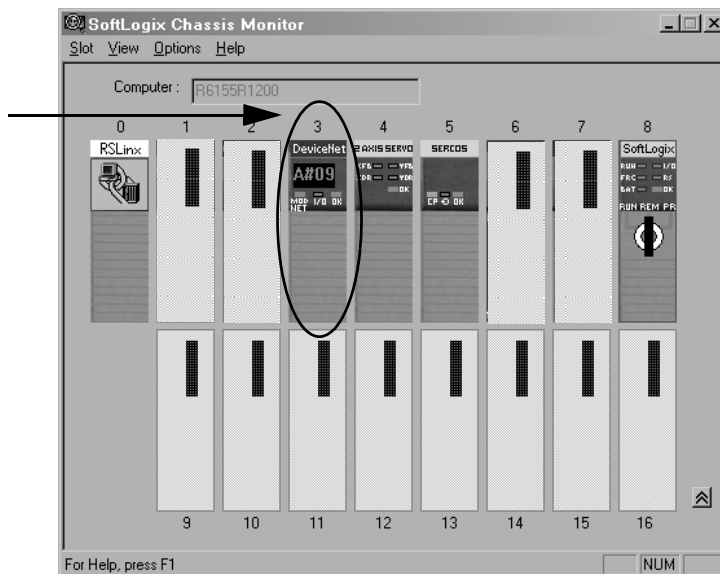

This chassis monitor has a 1784-PCIDS card installed in Slot 3.

### Step 3: Install the Communication Driver

Use RSLinx software to configure the DeviceNet communication driver for the 1784-PCIDS communication card. RSLinx software is a communication server providing device connectivity. For additional user information on RSLinx software, see the RSLinx Classic Getting Results Guide, publication [LINX-GR001](#).

Follow these steps to install and configure the DeviceNet communication driver.

1. Launch RSLinx software.
2. From the Communications menu, choose Configure Drivers.

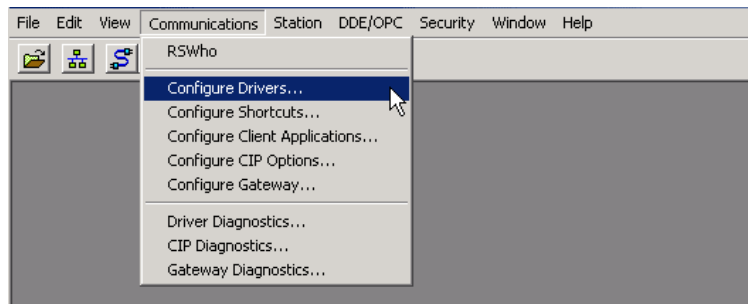

The Configure Drivers dialog box appears.

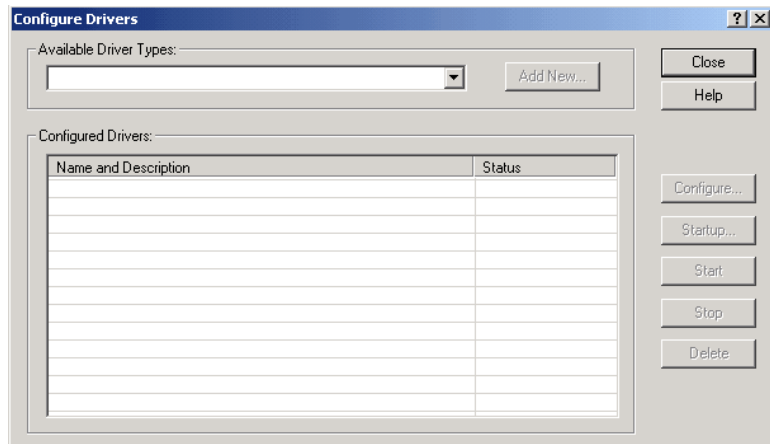

- From the Available Driver Types pull-down menu, choose the appropriate DeviceNet driver.

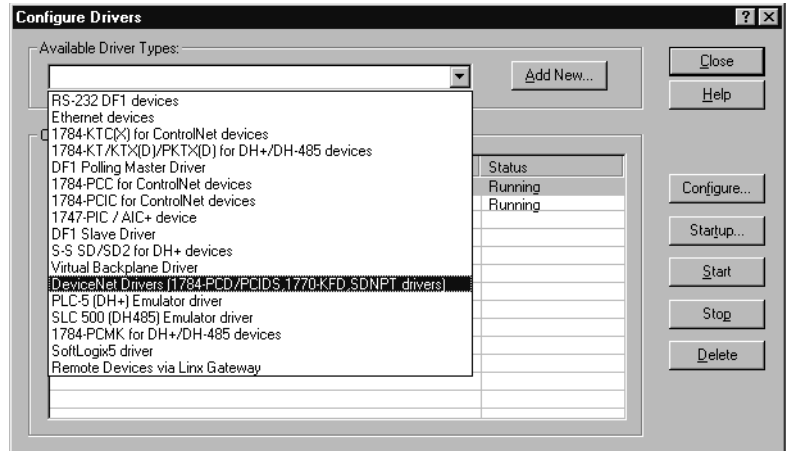

**TIP** The device settings are grayed out because you specified the baud rate and node address when you created the module in the SoftLogix Chassis Monitor.

- Click Add New.

The DeviceNet Driver Selection dialog box appears.

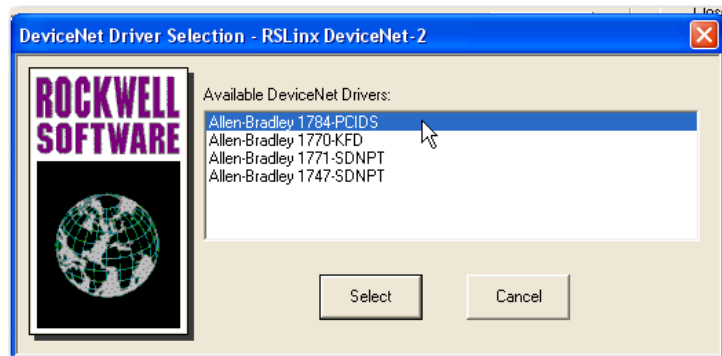

- Select the 1784-PCIDS driver and click Select.

The 1784-PCIDS Driver Configuration dialog box appears.

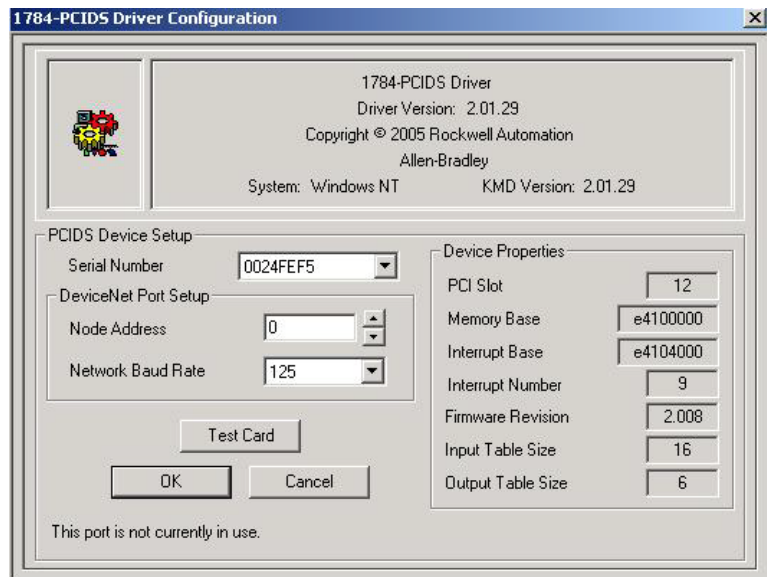

6. Click OK.

The Add New RSLinx Classic Driver dialog box appears.



7. Name the driver.
8. Click OK.

You will see the driver running.

9. Click Close.

---

**IMPORTANT** You install the DeviceNet communication driver only on the computer that you use to run RSNetWorx for DeviceNet software. This example assumes that you are running the SoftLogix controller and RSNetWorx software on the same computer.

---



## Step 4: Configure the Communication Card as Part of the Project

Use RSLogix 5000 software to map the 1784-PCIDS communication card as part of the SoftLogix project. In the Controller Organizer, add the communication card to the I/O Configuration folder.

You should already have added the SoftLogix controller to the project. See [Step 1: Create and Configure the Controller in the SoftLogix Chassis Monitor on page 27](#).

Your controller is offline.

1. In RSLogix 5000 software, right-click the I/O Configuration folder and choose New Module.

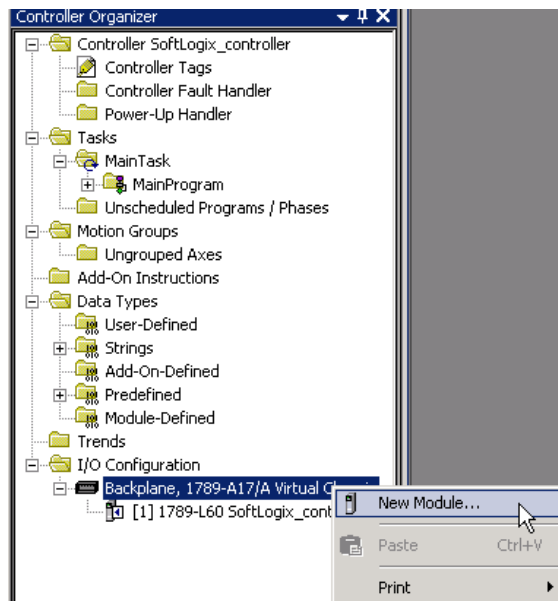

2. Expand the Communications list and select the 1784-PCIDS communication card.

The Select Module dialog box appears.

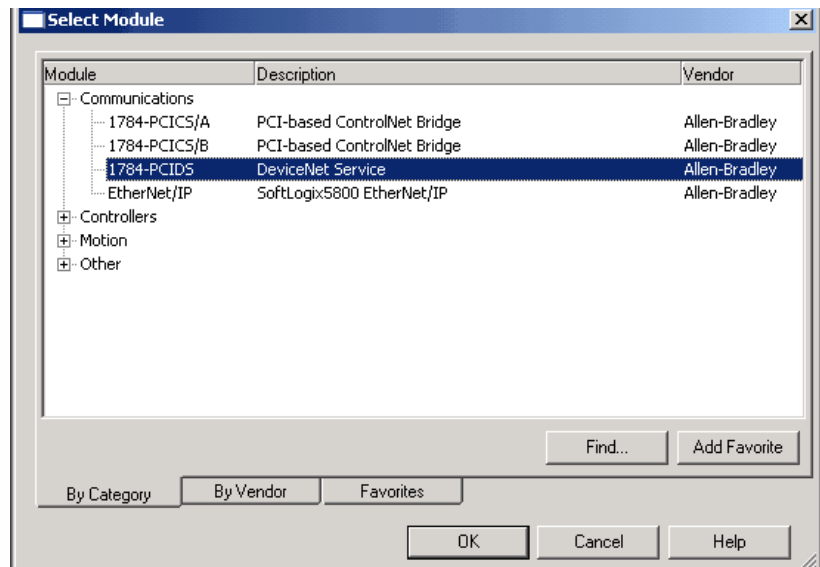

3. Click OK.

The Select Major Revision dialog box appears.

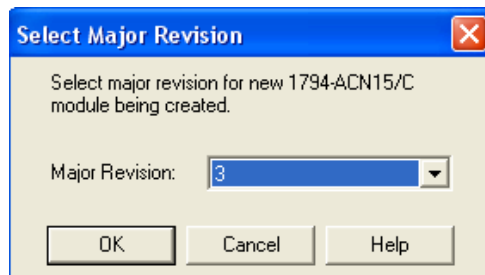

4. Choose the Major Revision number for this module.
5. Click OK.

The New Module dialog box appears.

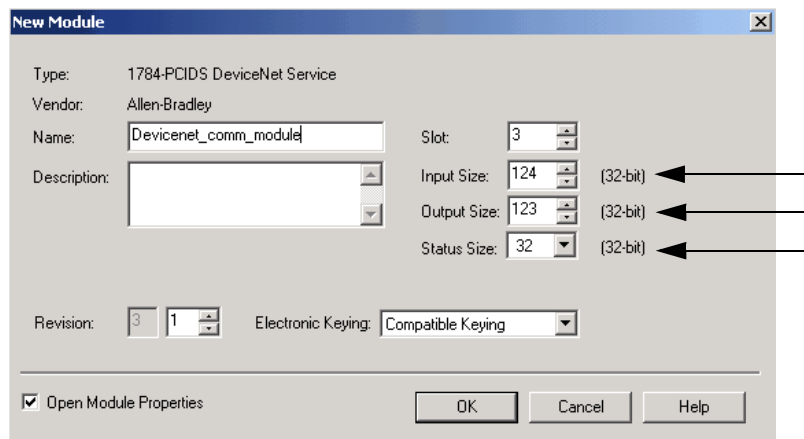

6. Enter the name and slot number, (for this example, slot number 3 is used, which matches the SoftLogix Chassis Monitor location), Input Size, Output Size, and Status Size.

Make sure your selections for Input Size, Output Size, and Status Size are large enough to hold the data you expect. If the sizes are too small, data truncates. If the sizes are too large, the software zero pads the data blocks.

7. Click the Open Module Properties box and click OK to complete the system configuration and develop your program logic.

### Step 5: Download the Project to the Controller

1. From the Communications menu, choose Who Active.

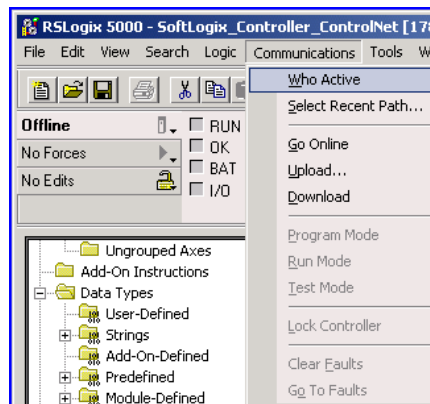

The Who Active dialog box appears.

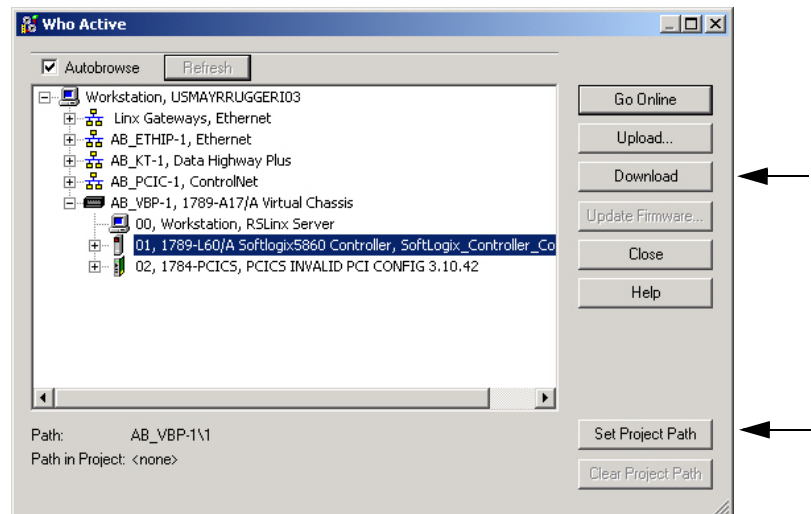

2. Browse to the SoftLogix controller.
3. Click Set Project Path button to cause this controller's path to be saved as part of the .acd and will link the .acd project with this path to the controller.

#### 4. Click Download.

The Download dialog box appears.

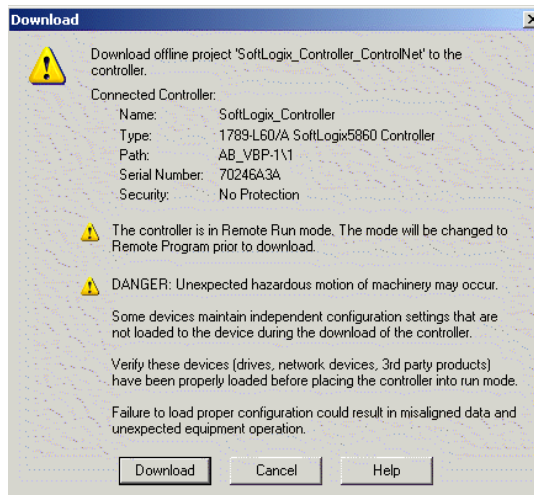

#### 5. Click Download on the Download dialog box.

This will download the .acd project into the controller and put you online with the controller.

---

**IMPORTANT** The virtual backplane driver must be installed via RSLinx software before you can download a project to the SoftLogix controller.

---

## Step 6: Define the Scanlist

Use RSNetWorx for DeviceNet software to survey the scanlist. This is assuming that you have already set up a network configuration in RSNetWorx for DeviceNet software. For more detailed information about how to set up multiple devices on your network, see the DeviceNet Network Configuration User Manual, publication [DNET-UM004](#).

The SoftLogix controller supports 32-bit words of data. You can have 124 words of input data, 123 words of output data, and 32 words of device status data. How you configure the DeviceNet devices determines how many words you use per device.

Most DeviceNet devices support 16-bit words. Take care how you map these into the 32-bit words used in RSLogix 5000 software. RSNetWorx for DeviceNet software lets you word-align the device data. While this might simplify the organization of the data, it might also limit the data you have available.

For detailed information on how to use RSNetWorx for DeviceNet software, see the RSNetWorx for DeviceNet Getting Results Guide, publication [DNET-GR001](#).

**IMPORTANT** The project must already be downloaded from RSLogix 5000 software to the controller and the controller must be in Program or Remote Program mode.

1. Launch RSNetWorx for DeviceNet software.
2. Go online to begin browsing the network.

Click to go online.

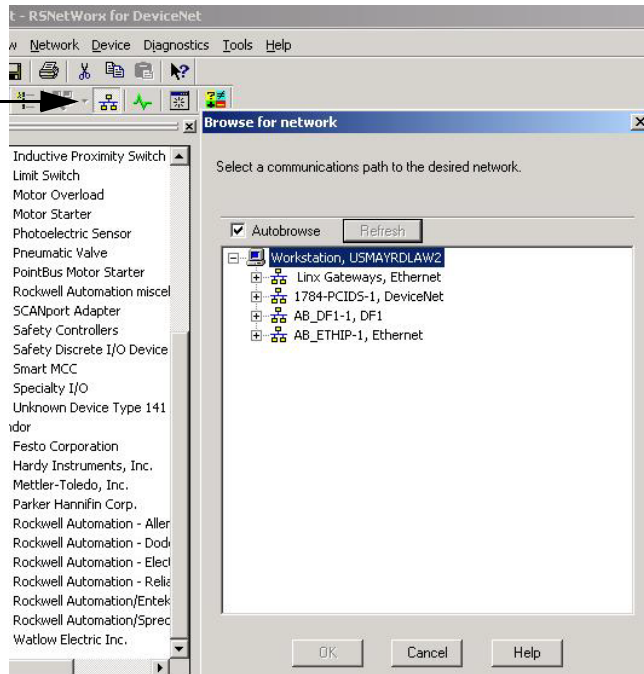

3. Browse to the DeviceNet network.

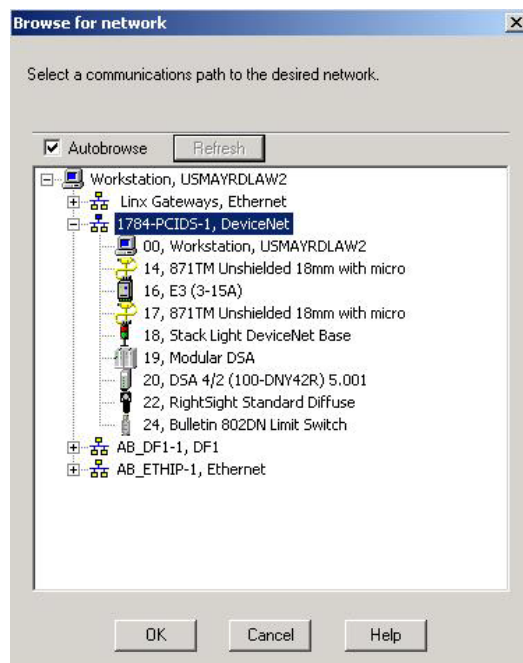

4. Click OK.

An upload/download prompt dialog box appears.

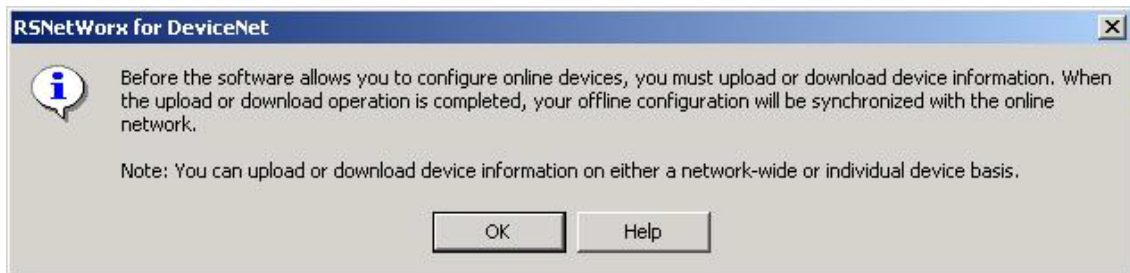

5. Click OK.

---

**IMPORTANT** If you cannot browse the network after installing the 1784-PCIDS card, check and make sure the status indicator on the card is green. If it is red, see the DeviceNet Universal PCI Scanner Card Installation Instructions, publication [1784-IN004](#), for detailed troubleshooting information about status indicators.

---

The RSNetWorx for DeviceNet network appears.

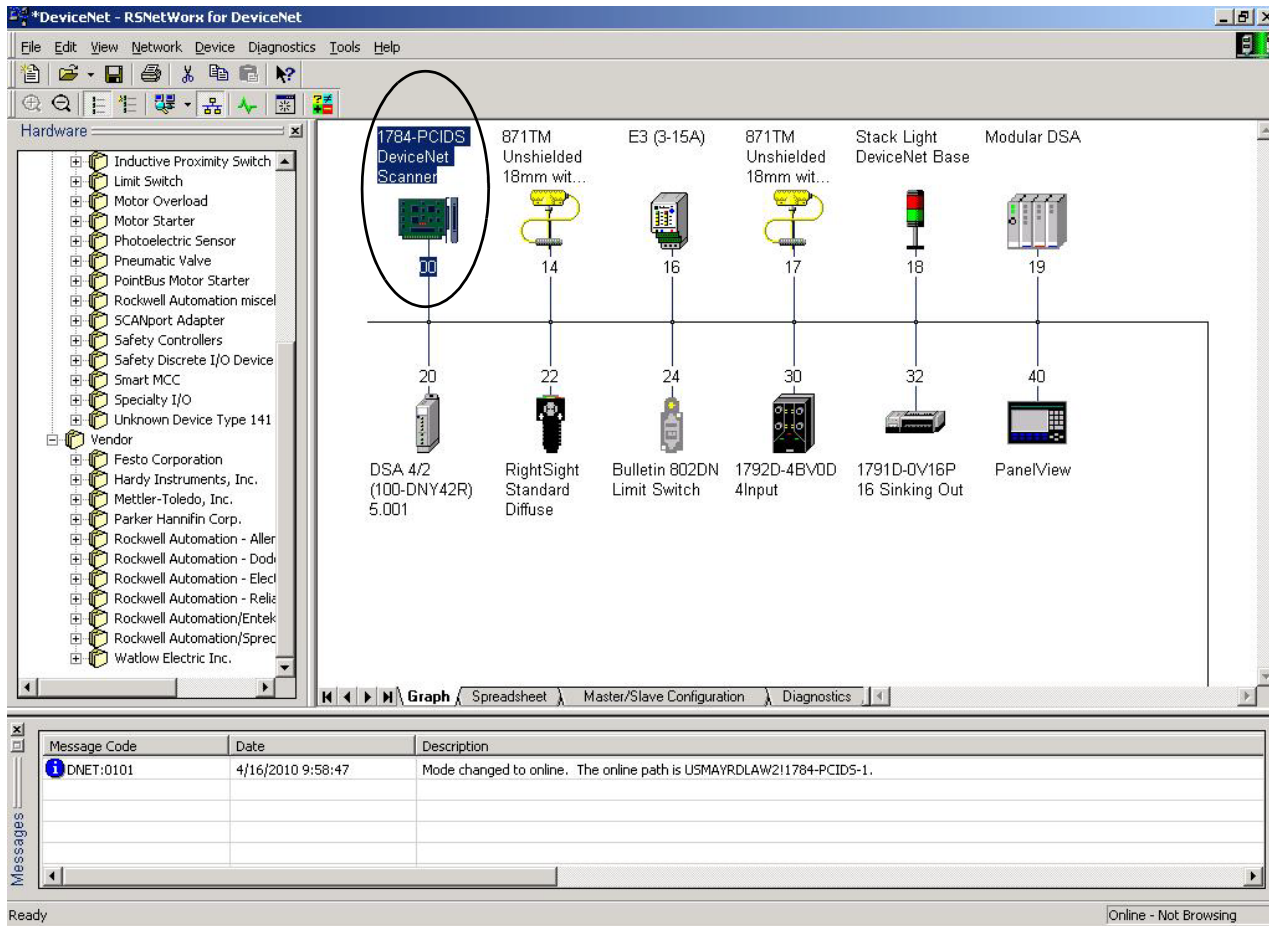

At this point, you can configure your device's network parameters so that I/O data lengths and contents are in the desired formats. Devices default to transmit and receive data format. Some device formats can be changed. Changes should be made to such devices prior to creating the scanlist.

For more detailed information about configuring parameters for specific devices, see the DeviceNet Network Configuration User Manual, publication [DNET-UM004](#).

6. Make any changes to specific device parameters as needed.
7. From the File menu, choose Save, to save the network changes to the project.

8. Double-click the 1784-PCIDS card in the RSNetWorx for DeviceNet Network Configuration dialog box.

The 1784-PCIDS General Device Properties dialog box appears.

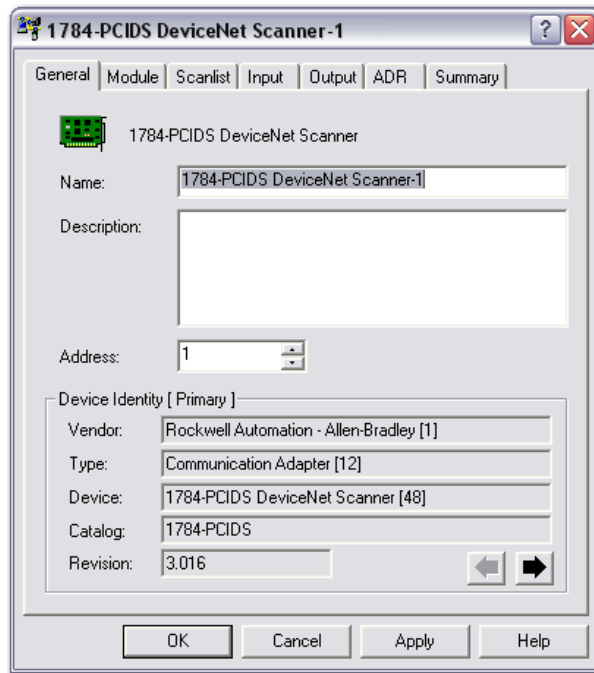

**Table 9 - General Device Properties Tab Descriptions**

Tab	Definition
General	On the General tab, view the device properties (including catalog or product name, current slot number address, and identification information).
Module	On the Module Configuration property tab, you can configure an adapter or any of the associated modules that reside in the selected chassis by: <ul style="list-style-type: none"> <li>• Altering appropriate chassis parameters (for example, chassis type and display hardware by fields).</li> <li>• Adding or deleting a module.</li> <li>• Changing the slot position of a module in the chassis.</li> <li>• Downloading/uploading individual adapter/module information to/from the network.</li> <li>• Configuring individual adapter or module parameters.</li> </ul>
Scanlist	On the Scanlist property tab, you can configure the scanner's scanlist table (SLT) and device-based I/O messaging parameters either online or offline. You define the scanning order of the DeviceNet scanlist here. The scanlist determines which devices of all of those available on the DeviceNet network the scanner may communicate with. The scanner itself, and the host personal computer, are not included in the scanlist, only I/O devices. The I/O messaging parameters determine how the scanner communicates with each I/O device that appears in the scanlist. By clicking the Edit I/O Parameters box on the Scanlist page, you can define how many inputs (Rx) and Outputs (Tx) you expect from each DeviceNet device. The parameters you specify here must match those of each particular I/O device.
Input	On the Input property tab, you can map device input data into the scanner's data table either online or offline and either automatically or manually. This information is uploaded to the software and downloaded to the scanner when you respectively upload and download the scanlist on the Scanlist property tab. The input map determines where the input data (the data received from each device) is mapped into the scanner's data tables. You can choose the name of the data table memory you want the input data mapped to and a start word offset, if desired. Input data is read from input image tables. The size of these tables is processor dependent. Mapping to and from these tables is done as a word index, offset from zero. No other mapping choices are available. There is no reserved status or command bytes in the mapped image tables.
Output	On the Output property tab, you can map device output data into the scanner's data table either online or offline and either automatically or manually. This information is uploaded to the software and downloaded to the scanner when you respectively upload and download the scanlist on the Scanlist tab. The output map determines where the output data (the data that is sent to each device) is mapped into the scanner's data tables. You can choose the name of the data table memory you want the output data mapped to and a start word offset, if desired. Output data is written to output image tables. The size of these tables is processor-dependent. Mapping to and from these tables is done as a word index, offset from zero. No other mapping choices are available. There is no reserved status or command bytes in the mapped image tables.

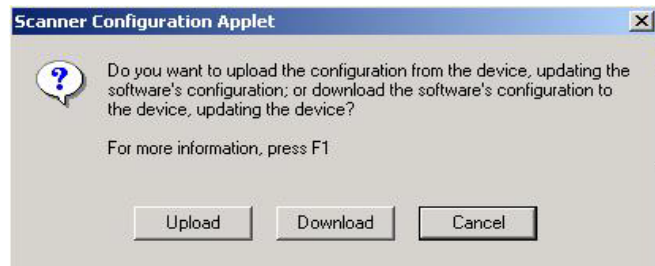

**Table 9 - General Device Properties Tab Descriptions**

Tab	Definition
ADR	On the ADR property tab, you can configure the automatic device replacement (ADR) parameters for scanners that support the ADR feature, which automates the replacement of a failed slave device on a DeviceNet network by returning it to the prior level of operation. This feature includes Configuration Recovery (CR) and Auto-address Recovery (AAR). By using the controls on this tab, you can choose ADR parameters and enable/disable this functionality either globally or on a device-specific basis.
Summary	Shows a summary of the configuration. This screen is read-only.

- Click the Scanlist tab to upload the configuration from the device to the software configuration.

The Scanner Configuration Applet dialog box appears.



- Click Upload.

The Scanlist 1784-PCIDS DeviceNet Scanner dialog box appears.

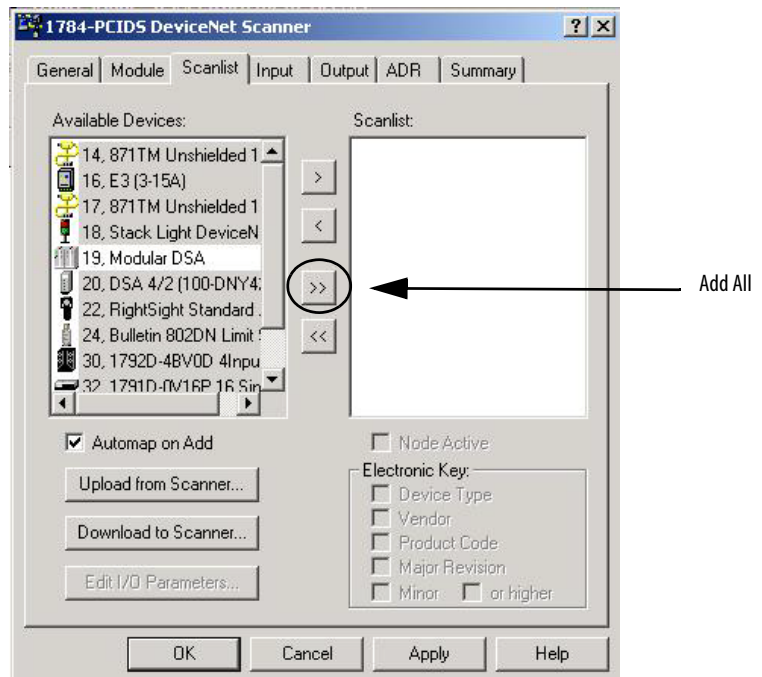

- Click Add All to add all of the available devices to the Scanlist.

The Full Scanlist dialog box appear.

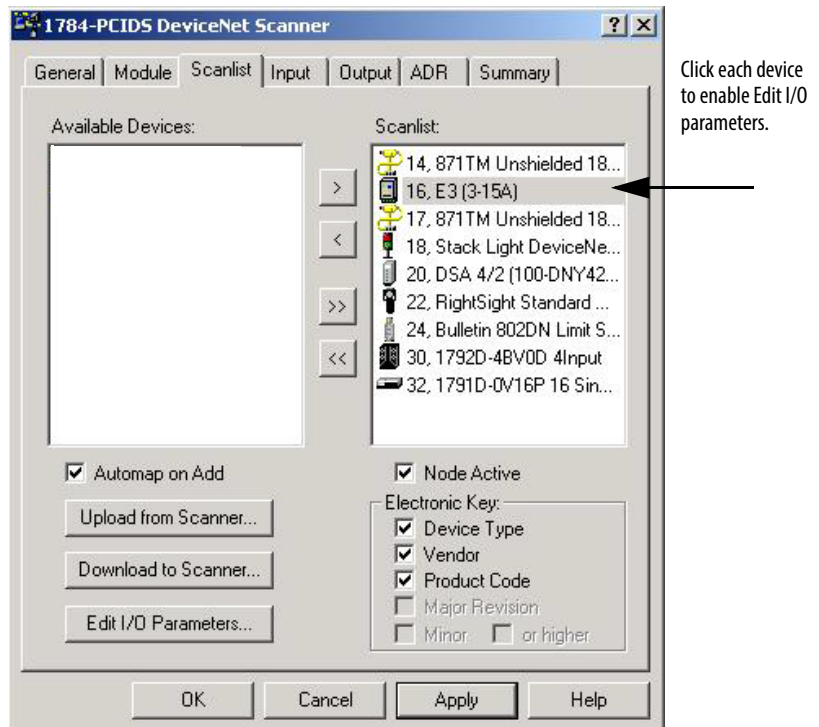

The I/O data is automatically loaded into the scanlist from the device's EDS file with default parameters set. If you want to change I/O Parameters for a device, perform the following steps.

- a. Click each device to enable the Edit I/O Parameters dialog box.

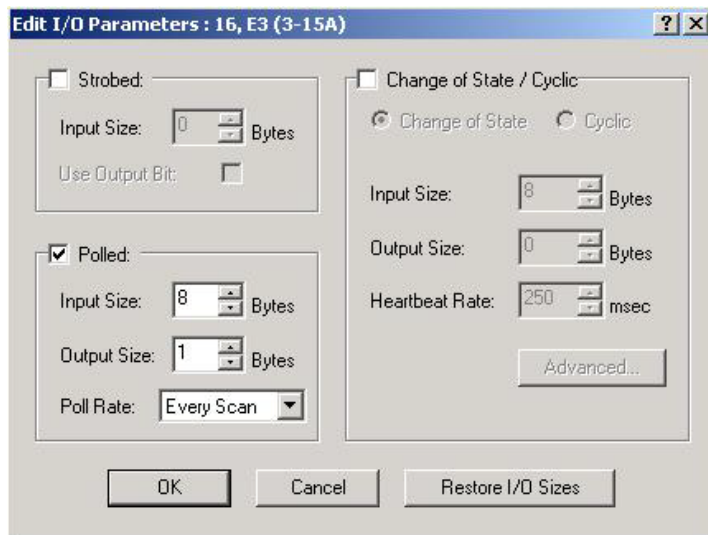

- b. Set the parameters for each device and click OK.

12. Click the Input tab.

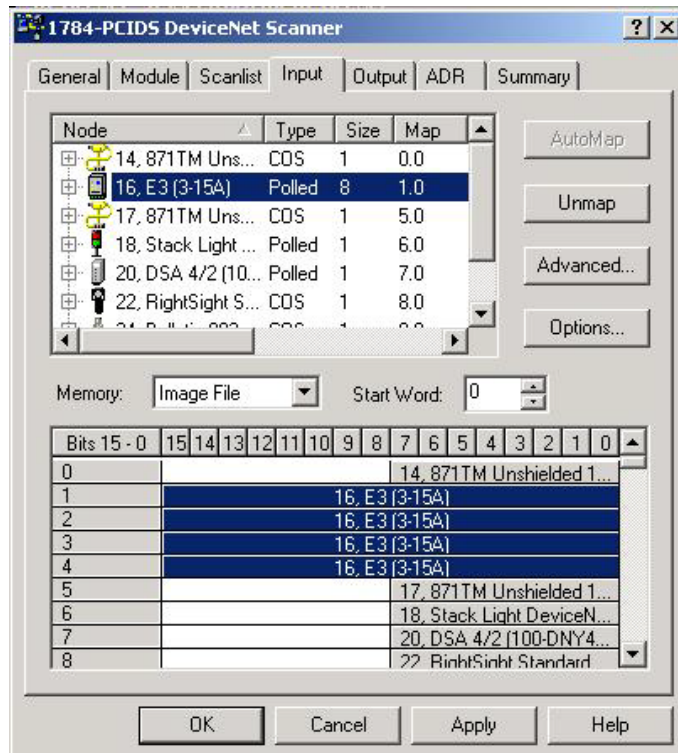

13. Verify input mapping.

14. Click the Output tab.

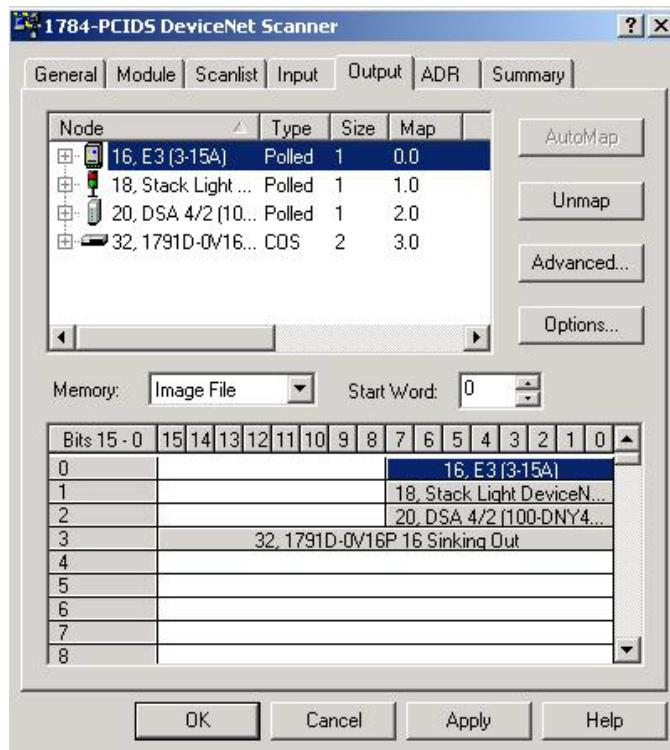

15. Verify output mapping.

16. Click Apply to download the parameters to the device.

The Scanner Configuration Applet dialog box appears.



17. Click Yes.
18. When finished, click OK.
19. From the main menu, choose Save to save the scanlist configuration.

**TIP** If you place the SoftLogix 5800 controller in Program mode with DeviceNet I/O currently mapped through a 1784-PCIDS module, and then you use RSNetWorx software to change the data mapping on the network, the controller does not detect this change until the 1784-PCIDS module is reset.

You can reset the module in the RSLogix 5000 Controller Organizer by following these steps.

1. Right-click the module and choose Properties.
2. Click the Module Info tab.

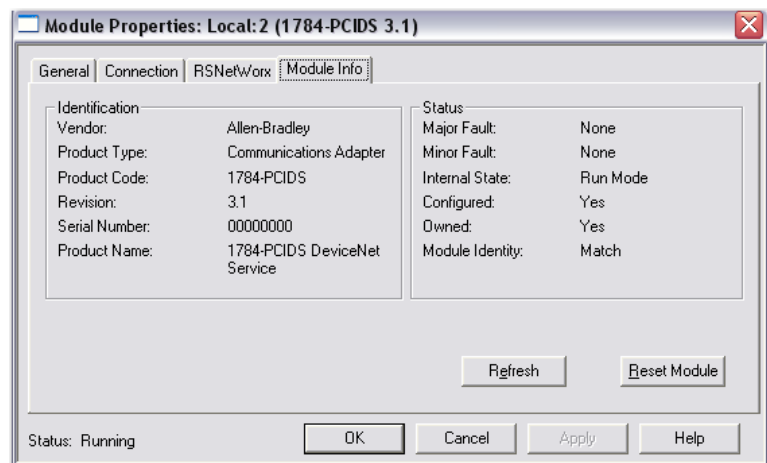

3. Click Reset Module.

You can also reset the module by removing and reinserting the module in the SoftLogix Chassis Monitor, which can be done while the SoftLogix controller is running. The connections are automatically reestablished after the 1784-PCIDS module is reset.



**WARNING:** Do not reset a module that is currently being used for control. The connection to the module is broken and control might be interrupted.

## Perform DeviceNet Test

The IOLinx 1784-PCIDS/CPCIDS Driver CD includes a stand-alone test application (called DNetTest.exe) that lets you diagnose simple anomalies over the network before the control application is available for integration.

In addition, you can use the application to make certain that the 1784-PCIDS card has been correctly installed and is functioning in the personal computer.

### Step 1: Start the Test Application

The test application is automatically installed as part of the driver installation procedure.

To start the test application, choose Start>Programs>Rockwell Software >IOLinx>IOLinx for DeviceNet>DeviceNet Test.

The DeviceNet Test Application dialog box appears.

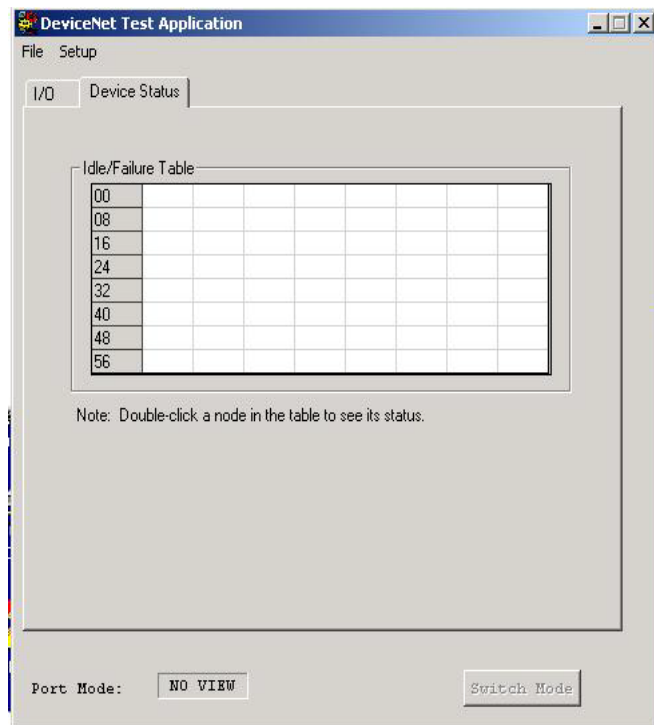

If the driver cannot establish communication with the module, an error message is displayed.

## Step 2: Configure the Port

You must configure the port the first time you use a 1784-PCIDS card.

To configure the port, follow these steps.

1. From Setup menu, choose Configure Port.

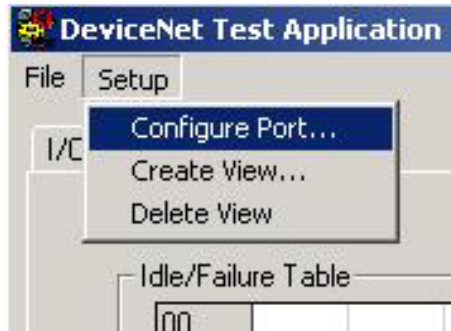

The DeviceNet Driver Selection dialog box appears.

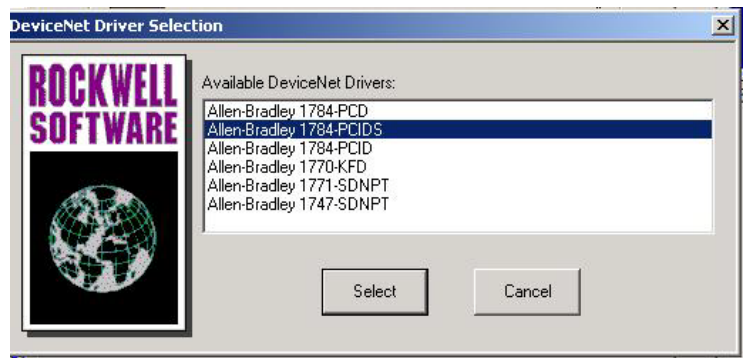

2. Select the Allen-Bradley 1784-PCIDS driver and click Select.

The 1784-PCIDS Drive Configuration dialog box appears.

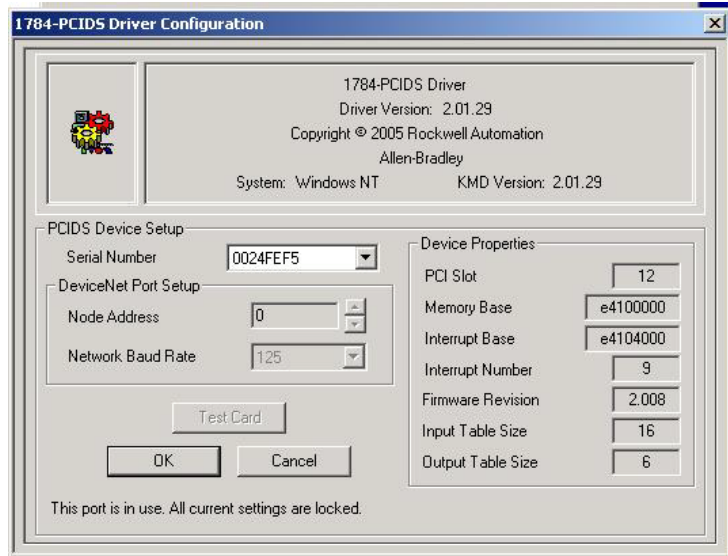

3. Click OK.

The DNetTest dialog box appears indicating the operation was successful.



4. Click OK.

The Port Configuration dialog appears indicating that the port has been configured.



5. Click OK.

### Step 3: Create a View

1. From the Setup menu, choose Create View.

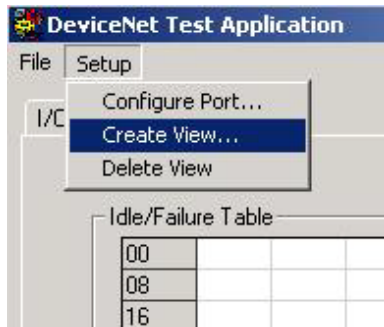

The View Creation Parameters dialog box appears.

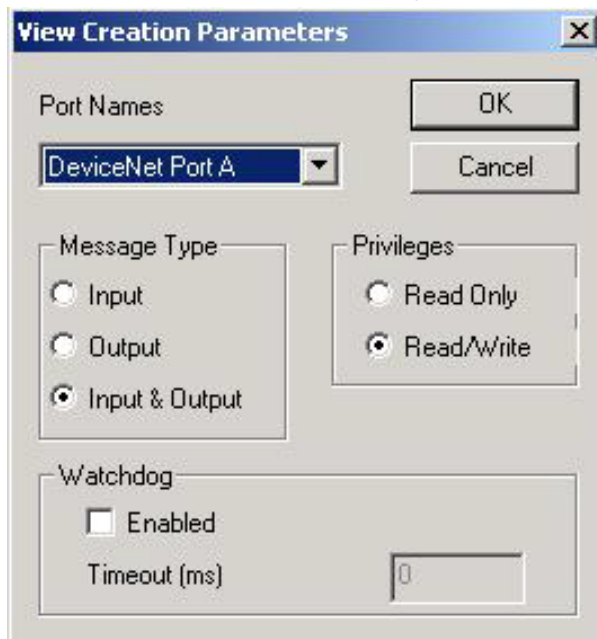

2. Choose the port name matching the port for the view you are creating.
3. Click the Message Type (input, output, or input/output) that you want to use for the view you are creating.



4. Click the Privileges (read only, read/write) that you want to use for the view that you are creating.
5. If you want to use the Watchdog timer for the view you are creating, check Enabled and enter the watchdog timeout value (in milliseconds) that you want to use.
6. Click OK.

The DNetTest dialog box appears indicating the operation was successful.

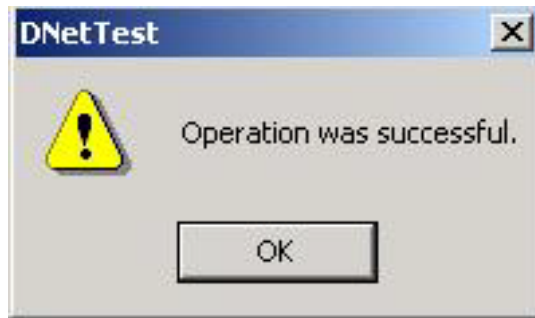

7. Click OK.

The DeviceNet Test Application dialog box appears.

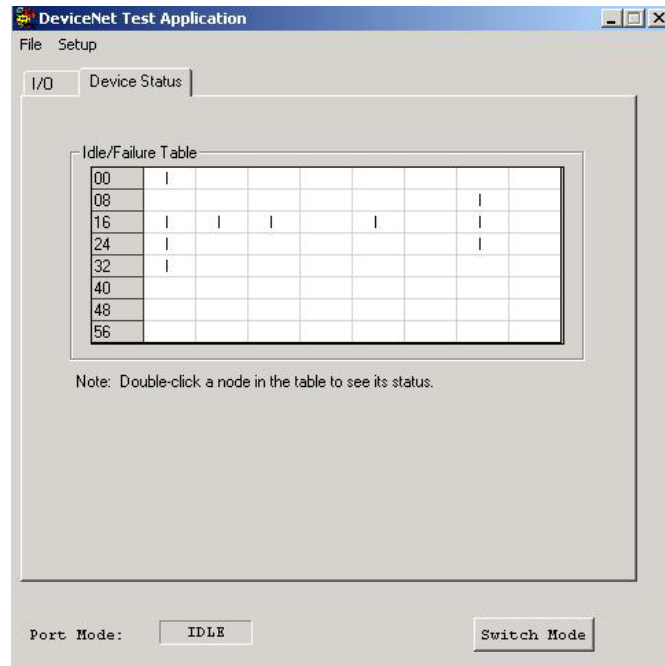

8. Click the Device Status tab to view the status.

The Device Status tab displays an Idle/Failure Table where you can double-click a node to see its status, for example, MAC ID, status code, and status messages such as .device stopped communicating.

If you double-click an empty node, you see the message 'OK' or 'Not In Scan List'.

## Step 4: Read Inputs and Write Outputs

1. Click the I/O tab.

The I/O dialog box appears.

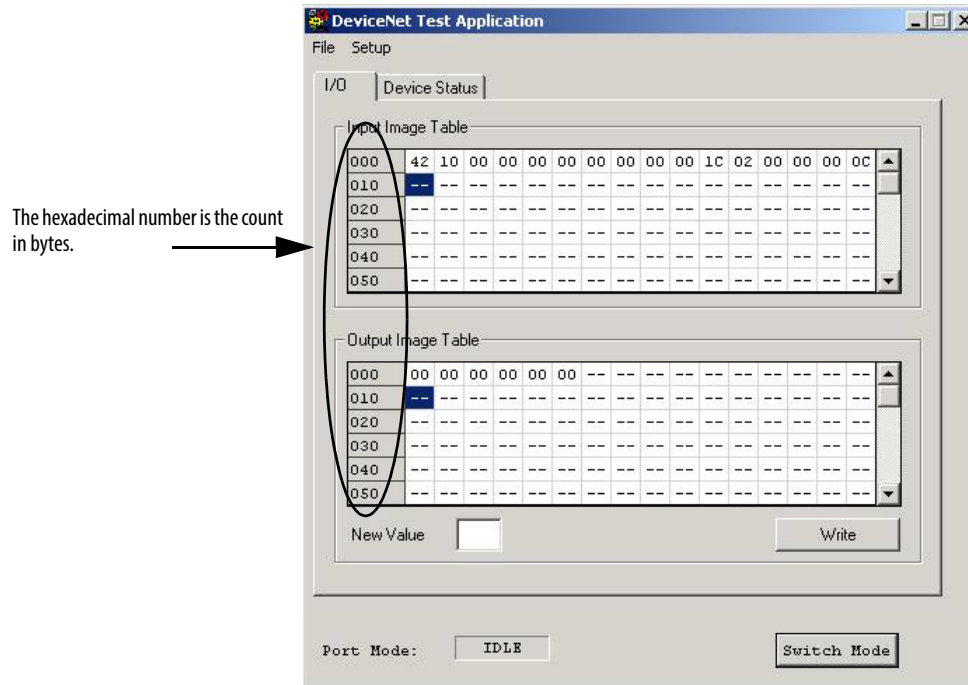

The DeviceNet Test Application lets you read as many as 2048 bytes from the input image table of the 1784-PCIDS card. The Input Image Table is displayed and is automatically updated when inputs change.

The DeviceNet Test Application lets you write as many as 2048 bytes to the output image table of the scanner.

2. On the I/O tab, choose the desired bytes in the Output Image Table.
3. Type the desired values in the New Value field.
4. Click Write to perform the data transfer.

**TIP** The hexadecimal number on the left side of the input or output table is the count in bytes.

## Step 5: Change the Scanner Mode

The Port Mode window displays the current mode of the scanner: Run, Idle, No View.

When the view is initially created, the scanner mode is set to Idle. The view state must be set to Run for the I/O devices to energize their outputs based on the output data from the scanner.



**WARNING:** Changing the view state to Run will cause the I/O devices to energize their outputs based on the output data from the scanner.

To avoid personal injury and property damage, before setting the view state to Run, verify that the output values are appropriate for the I/O devices.

---

Use Switch Mode to change the mode between Run and Idle. Once the mode is set to Run, active outputs are sent to the associated I/O devices.

For more detailed information about the IOLinx DeviceNet Test utility, see the DeviceNet Universal PCI Scanner Card Installation Instructions, publication [1784-IN004](#).

## DeviceNet I/O Data

I/O information is presented as a structure of multiple fields that depend on the specific features of the I/O module. The name of the structure is based on the location of the I/O module in the system. Each I/O tag is automatically created when you configure the I/O module through the programming software. Each tag name follows this format:

Location:SlotNumber:Type.MemberName.SubMemberName.Bit

Tag Name	Description
Location	Identifies network location. LOCAL = identifies communication card within the computer.
SlotNumber	Slot number of I/O module in its chassis.
Type	Type of data: I = input O = output C = configuration S = status
MemberName	Specific data from the I/O module; depends on the type of data the module can store. For example, Data and Fault are possible fields of data for an I/O module. Data is the common name for values that are sent to or received from I/O points.
SubMemberName	Specific data related to a MemberName.
Bit (optional)	Specific point on the I/O module; depends on the size of the I/O module (0...31 for a 32-point module).

**EXAMPLE** The 1784-PCIDS card in this example is slot 3.

**ATTENTION:** The data for a 1784-PCIDS card is always configured as a rack-optimized connection.

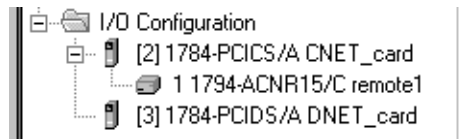

The rack-optimized connection creates a DINT element for each possible I/O module connected to the device in slot 3, 'Local:3.' The array Local:3:I.Data contains the possible input elements; the Local:3:O.Data contains the possible output elements.

Tag Name	Value	Force Mask	Style	Type
[-] Local:3:I	{...}	{...}		AB:1784_PCIDS_500Bytes:I:0
[-] Local:3:I.StatusRegister	{...}	{...}		AB:1784_PCIDS_StatusRegister:I:0
[+] Local:3:I.Data	{...}	{...}	Decimal	DINT[124]
[-] Local:3:O	{...}	{...}		AB:1784_PCIDS_496Bytes:O:0
[-] Local:3:O.CommandRegister	{...}	{...}		AB:1784_PCIDS_CommandRegister:O:0
[-] Local:3:O.CommandRegister.Run	0		Decimal	BOOL
[-] Local:3:O.CommandRegister.Fault	0		Decimal	BOOL
[-] Local:3:O.CommandRegister.DisableNetwork	0		Decimal	BOOL
[-] Local:3:O.CommandRegister.HaltScanner	0		Decimal	BOOL
[-] Local:3:O.CommandRegister.Reset	0		Decimal	BOOL
[+] Local:3:O.Data	{...}	{...}	Decimal	DINT[123]
[+] Local:3:S	{...}	{...}		AB:1784_PCIDS_Status_128Bytes:S:0

The index number on the array element refers to the same numbered word mapped to the device in RSNetWorx for DeviceNet. Depending on the device, there can be several words mapped to one device. You can create aliases to the elements you actually use to more accurately identify the data you need.

### Determine How Often to Update Data

When you configure the 1784-PCIDS card, you can specify a requested packet interval (RPI) time. The RPI you set specifies the maximum amount of time between data updates.

The 1784-PCIDS card supports an RPI range of 2.0...750.0 ms. The default is 5.0 ms.

## Place the Communication Card in Run Mode

To place the 1784-PCIDS card in Run mode, your program logic needs to set the CommandRegister.Run bit in the output word for the card.

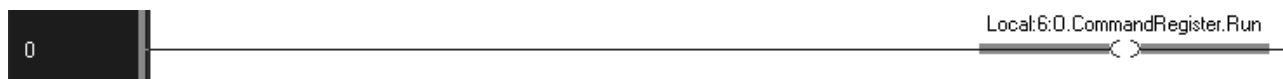
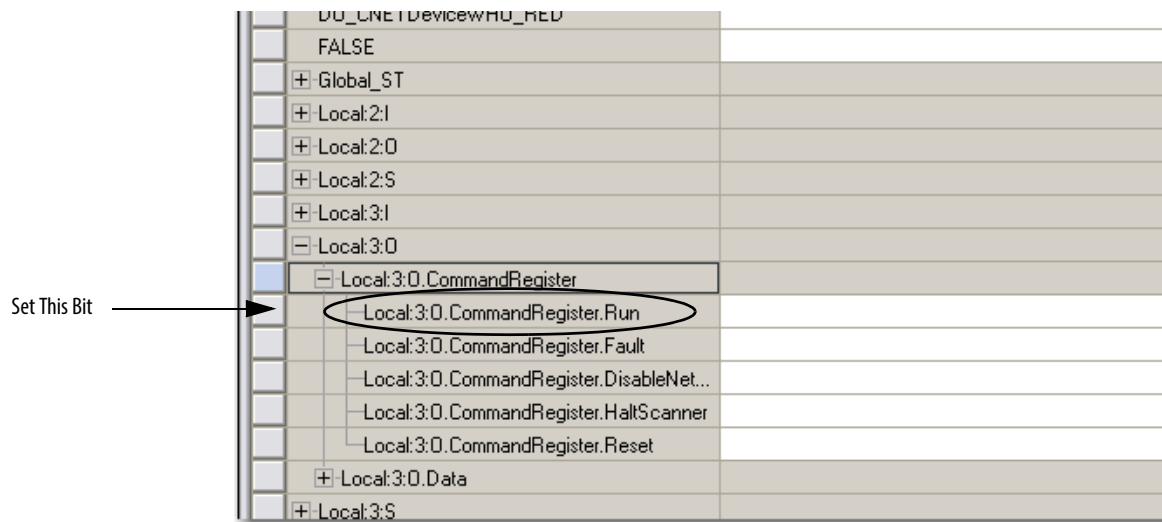

## CommandRegister Bits

This table describes how the 1784-PCIDS card uses the CommandRegister bits.

CommandRegister.Run Bit	Description
Zero (0)	Idle mode. In Idle mode, the card still receives inputs from its slave devices on the network, but the card does not send active output data to the devices.
One (1)	Run mode. In Run mode, the card sends active outputs on the network and receives inputs.

## StatusRegister

The input data for the 1784-PCIDS card includes a StatusRegister.

The screenshot shows a software interface for viewing controller tags. The window title is 'Controller Tags - quick\_start(controller)'. It has a search bar with 'Scope: quick\_start(controller)', 'Show: Show All', and 'Sort: Tag Name'. Below is a table with columns 'Tag Name', 'Value', and 'Force Mask'. The 'Tag Name' column shows a tree structure:
 

- Local:3:1 (expanded)
  - Local:3:1.StatusRegister** (circled in red)
  - Local:3:1.Data
- Local:3:0 (expanded)
  - Local:3:0.CommandRegister (expanded)
    - Local:3:0.CommandRegister.Run
    - Local:3:0.CommandRegister.Fault
    - Local:3:0.CommandRegister.DisableNetwork
    - Local:3:0.CommandRegister.HaltScanner
    - Local:3:0.CommandRegister.Reset
  - Local:3:0.Data
- Local:3:5

 An arrow labeled 'StatusRegister Bits' points to the circled 'Local:3:1.StatusRegister' tag.

This table describes how the 1784-PCIDS card uses the StatusRegister bits.

StatusRegister Bit	Description
StatusRegister.Run	This bit echoes the CommandRegister.Run bit to determine if the card is in Run or Idle mode. A 0 in this bit means the card is in Idle. A 1 means the card is in Run mode.
StatusRegister.Fault	This bit identifies whether the card is in Fault mode. The SoftLogix controller sets this bit based on the corresponding IOLinx status.
StatusRegister.DisableNetwork	The SoftLogix controller does not use this bit. The controller clears this bit to 0.
StatusRegister.DeviceFailure	This bit determines if general communication is OK between the card and its slave nodes. A node falling off the network or experiencing other communication anomalies to any device on the card's scanlist sets this bit to 1. This bit is used in conjunction with the DeviceFailure table in the Status section to determine which nodes are having communication anomalies. A 0 in this bit means that all the slave nodes are being successfully communicated to. A 1 means the card has at least one device with communication anomalies.
StatusRegister.Autoverify	This bit determines if the data Transmit and Receive sizes in the scanlist are correct. Any node that has data sizes that don't match the sizes defined in the scanlist causes the bit to be set to 1. This bit is used in conjunction with the AutoVerify table in the Status section to determine which nodes have incorrect data sizes. A 0 in this bit means that all the slaves have correct data sizes. A 1 means the card has at least one device on its scanlist with an incorrect data size.
StatusRegister.CommFailure	This bit identifies when a channel-wide communication fault happens with the card. For example, if the card detects severe communication anomalies on the network, it goes into a Bus Off condition. This also causes the StatusRegister.CommFailure bit to turn on. A 0 in this bit means that the card is communicating correctly. A 1 means the card detected a channel-wide communication anomaly.
StatusRegister.DupNodeFail	This bit shows if the card is attempting to go online on a DeviceNet network with the same node number as an existing device on the network. A 0 in this bit means that the card has not detected another node on the network with the same node number as the card. A 1 means that the card has the same node number as an existing device on the network.
StatusRegister.DnetPowerDetect	This bit shows if the card has detected that the DeviceNet 24V DC power is connected to its network connector and is energized. A 0 in this bit means that the card has detected DeviceNet power on its network connector. A 1 means that the card has not detected DeviceNet power on its network connector.

## Status Data Elements

The status data for the 1784-PCIDS card includes several elements.

Status Data Elements →

[-] Local:3:S	{...}	{...}		AB:1784_PCIDS_
[-] Local:3:S.ScanCounter	2#0000_000...		Binary	DINT
[-] Local:3:S.DeviceFailureRegister	{...}	{...}	Binary	SINT[8]
[-] Local:3:S.AutoverifyFailureRegister	{...}	{...}	Binary	SINT[8]
[-] Local:3:S.DeviceIdleRegister	{...}	{...}	Binary	SINT[8]
[-] Local:3:S.ActiveNodeRegister	{...}	{...}	Binary	SINT[8]
[-] Local:3:S.StatusDisplay	{...}	{...}	Binary	SINT[4]
[-] Local:3:S.ScannerAddress	16#00		Hex	SINT
[-] Local:3:S.ScannerStatus	16#00		Hex	SINT
[-] Local:3:S.ScrollingDeviceAddress	16#00		Hex	SINT
[-] Local:3:S.ScrollingDeviceStatus	16#00		Hex	SINT
[-] Local:3:S.DeviceStatus	{...}	{...}	Hex	SINT[64]
[-] motion_group1	{...}	{...}		MOTION_GROUP
[-] servo_1_axis	{...}	{...}		AXIS_SERVO
[-] servo_drive_axis	{...}	{...}		AXIS_SERVO_D...

This table describes the status data for a 1784-PCIDS card.

Status Element	Data Type	Default Display Style
S.ScanCounter	DINT	Binary
S.DeviceFailureRegister	SINT[8]	Binary
S.AutoverifyFailureRegister	SINT[8]	Binary
S.DeviceIdleRegister	SINT[8]	Binary
S.ActiveNodeRegister	SINT[8]	Binary
S.StatusDisplay	SINT[4]	Binary
S.ScannerAddress	SINT	Hex
S.ScannerStatus	SINT	Hex
S.ScrollingDeviceAddress	SINT	Hex
S.ScrollingDeviceStatus	SINT	Hex
S.DeviceStatus	SINT[64]	Hex



## Example: SoftLogix Controller and DeviceNet I/O

In this example, one SoftLogix controller controls I/O modules through a 1784-PCIDS communication card.

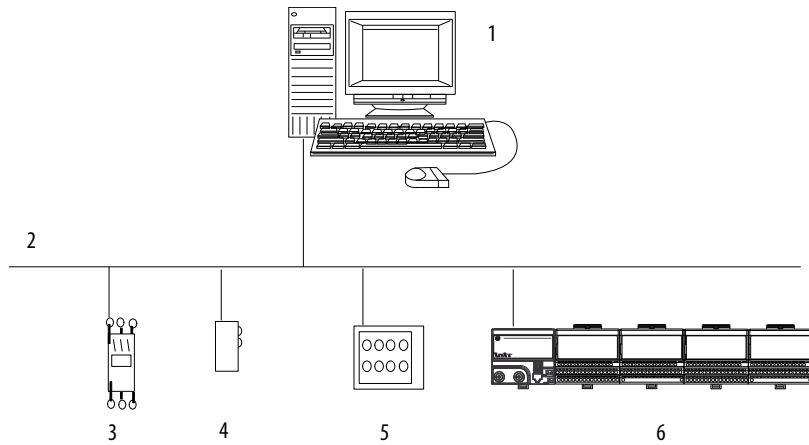

Item	Description
1	SoftLogix Controller
2	DeviceNet Network
3	Device 1
4	Device 2
5	Device 3
6	Device 4

This example has a SoftLogix controller controlling four DeviceNet devices. The controller automatically creates a rack-optimized connection for the I/O data.

The tag name for the rack-optimized array tag is based on the slot number of the 1784-PCIDS card. For example, if you install the 1784-PCIDS card in slot 3 of the controller, the software automatically creates Local:3:I and Local:3:O data structures.

## Create Alias Tags

You might want to create alias tags to better represent the elements of the input and output array tags. An alias for an I/O point does the following:

- Provides a descriptive name for the device that is wired to the point.
- Represents the value of the point. When one changes, the other reflects the change.

When you enter an alias tag into programming logic, the programming software displays the original tag, along with the alias.

### EXAMPLE

The following logic was initially programmed by using descriptive tag names, such as start and motor. Later, the tags were converted to aliases for the corresponding I/O devices.

- Start is an alias for the push button at bit 1 of word 0 of the module in slot 5 of the local chassis. When the push button is on, start is on.
- Motor is an alias for the starter contractor at bit 0 of word 0 of the module in slot 5 of the local chassis. When motor turns on, the starter contractor turns on.

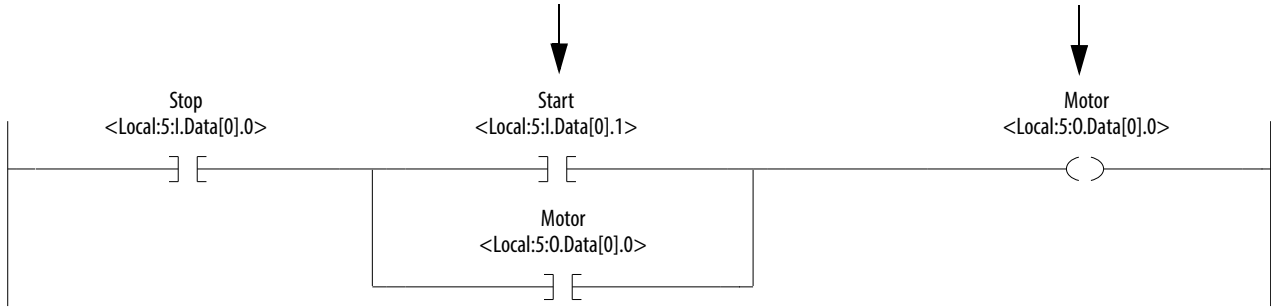

If you want to choose the 1784-PCIDS card from an online list of available devices, such as Browse Network in RSNetWorx for DeviceNet software, choose the 1784-PCIDS card from outside of the virtual chassis.

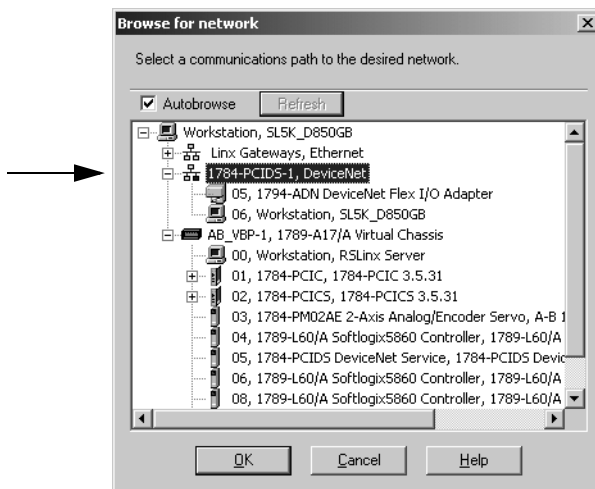

## Communicate with Devices on a ControlNet Network

Topic	Page
Configure Your System for a ControlNet Network	195
ControlNet I/O Data	219
Example 1: SoftLogix Controller and ControlNet I/O	222
Example 2: SoftLogix Controller to SoftLogix Controller	223
Example 3: SoftLogix Controller to Other Devices	228
Example 4: Use the SoftLogix Controller as a Gateway	234

This chapter provides detailed information about configuring and accessing your SoftLogix controller on a ControlNet network.

**IMPORTANT** ControlNet modules are not currently supported in RSLogix 5000 software on 64-bit Windows operating systems.

ControlNet is supported in SoftLogix software, version 20 or earlier.

ControlNet is not supported for SoftLogix controllers in the Studio 5000 environment.

For additional information about communicating with ControlNet devices, see the ControlNet Network Configuration User Manual, publication [CNET-UM001](#). The manual provides information about how to send messages and about the production and consumption of data over a ControlNet network.

### Configure Your System for a ControlNet Network

For the SoftLogix controller to operate on a ControlNet network, you need the following:

- ControlNet communication card to send messages or control I/O over the ControlNet network.

If you want to	Use this card
Send messages only	1784-PCIC
Any combination of sending messages, I/O control, and produced/consumed tags	1784-PCICS

- RSLink software to install the virtual backplane driver.

You install the virtual backplane driver only once on the computer running the SoftLogix controller. (This chapter assumes you have already installed the driver.)

- RSLogix 5000 software to configure the communication card as part of the SoftLogix system.
- RSNetWorx for ControlNet software to schedule the SoftLogix system on the network.

### Step 1: Install the Hardware

Make sure the 1784-PCICS communication card is properly installed in the computer. The following example shows the 1784-PCICS card; the configuration for a 1784-PCIC communication card is very similar. To install the card, you need to do the following:

- Install the card in any available PCI slot within the computer.

It does not matter which PCI slot you use for the communication card. The PCI slot in the computer does not correspond to the backplane slot in the SoftLogix Chassis Monitor. You use the SoftLogix Chassis Monitor to place the communication card in a specific backplane slot.

- Make a label to place on the mounting bracket of the card, or use a pen to write on the mounting bracket of the card. The label should include the serial number of the card and a name you can use to identify the card from any others you might install in the computer.

The example configuration below shows a computer running a SoftLogix controller with a 1784-PCICS communication card that uses redundant cabling.

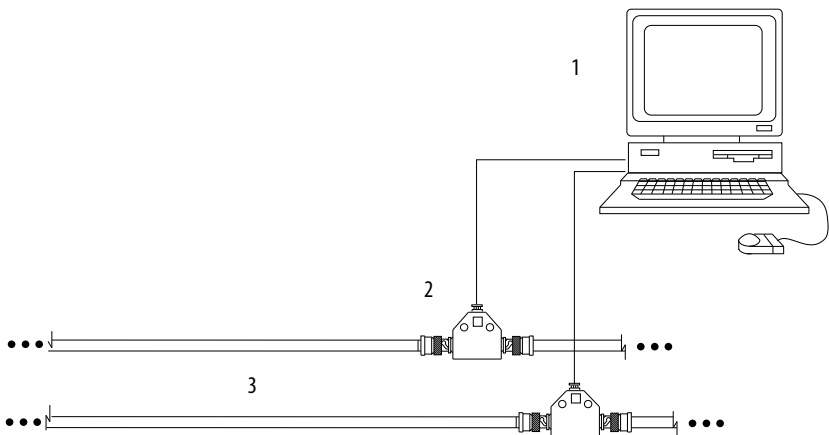

Item	Description
1	Computer running a SoftLogix controller with a 1784-PCICS communication card
2	1786-TPR, 1786-TPS, 1786-TPYR, or 1786-TPYS tap
3	ControlNet network

---

**IMPORTANT** Remember the serial number and name of each communication card you install. You use this information to identify which card you want in which slot of the SoftLogix Chassis Monitor.

---

For more information about installing a 1784-PCICS communication card, see the ControlNet Universal PCI Communication Interface Card Installation Instructions, publication [1784-IN003](#).

## Step 2: Create the Communication Card in the SoftLogix Chassis Monitor

Before you can connect the SoftLogix system to the ControlNet network, you must create the 1784-PCICS card as part of the SoftLogix Chassis Monitor. Follow these steps.

1. In the SoftLogix Chassis Monitor, from the Slot menu, choose Create Module.

Or right-click the appropriate slot and choose Create.



The Select Module dialog box appears.

2. In the Select Module dialog box, choose the 1784-PCICS ControlNet PCI Scanner.
3. Choose the backplane slot number.

If you are using a 1784-PCIC card, choose the 1784-PCIC ControlNet PCI Messaging card.

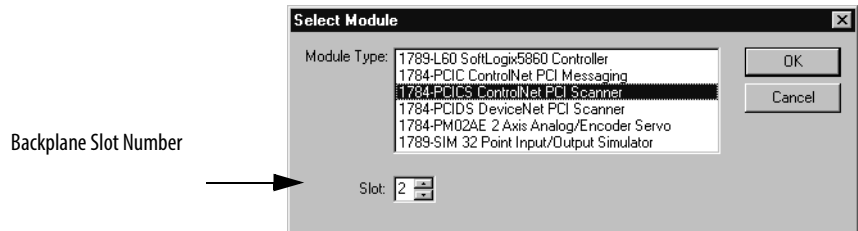

4. Click OK.

The Select Device dialog box appears.

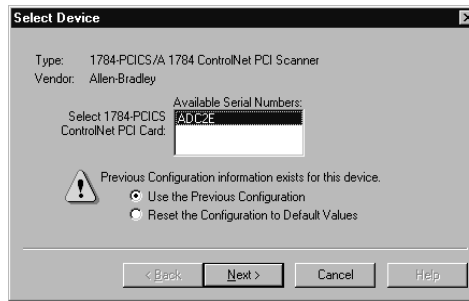

5. Select the serial number of the 1784-PCICS card you want.

If you previously configured the 1784-PCICS card that you selected by serial number, the chassis monitor remembers the configuration from the last time you used the card (whether in the same slot or not).

6. Click Next.

The General dialog box appears.

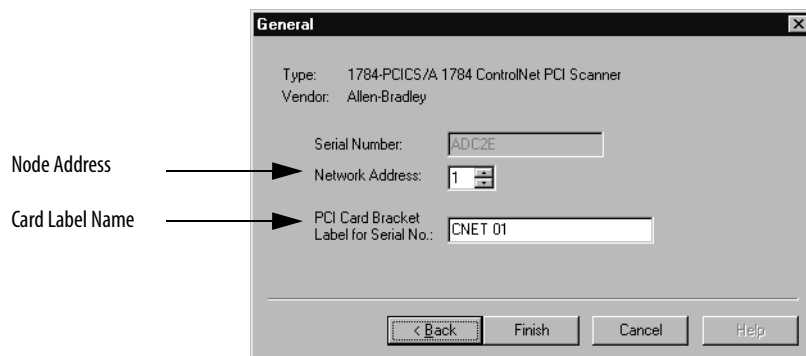

7. In the General dialog box, specify the configuration settings for the 1784 PCICS card. Specify the network node address on the ControlNet network.
8. Enter the label name for the card (this is the name you wrote on the label of the card to help you identify the card from others on the same computer).
9. Click Finish.

For RSLogix 5000 software, version 20.00.00 or later, you can specify any slot number for the communication card, as long as the RSLinx software module is positioned in a slot other than its default 0. See [page 29](#).

By creating the card in the virtual chassis, you automatically install the communication driver information needed by the SoftLogix controller.

---

**IMPORTANT** Do not use RSLinx software to install the communication driver for either the 1784-PCICS or 1784-PCIC communication card. Installing the communication driver through RSLinx software adds the potential for conflicting configuration between RSLinx software and the SoftLogix Chassis Monitor.

---

After you add the card to the chassis monitor, you can browse the network by expanding the Virtual Backplane driver and then expanding the port on the desired 1784-PCICS or 1784-PCIC communication card. Browsing ControlNet through the Virtual Backplane driver provides the same functionality as the RSLinx driver.

This example shows the 1784-PCICS card as a virtual module in the SoftLogix Chassis Monitor in slot 2. The status indicators on the virtual monitor emulate a 1756-CNBR communication module.

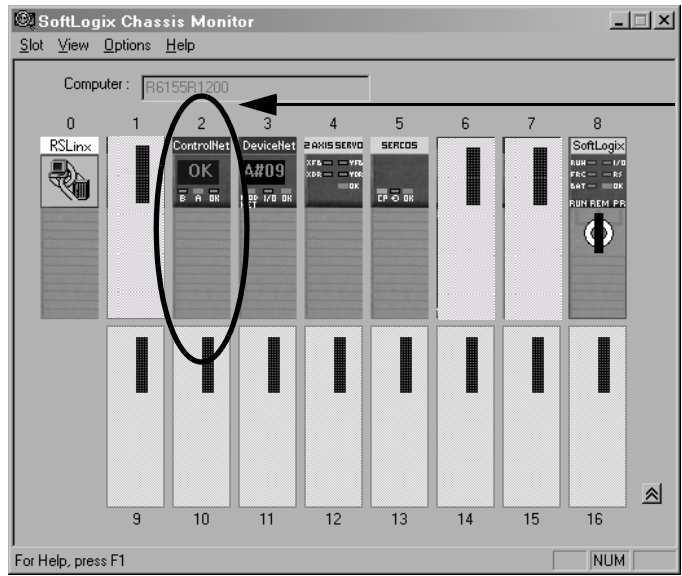

This chassis monitor has a 1784-PCICS card installed in slot 2.

### Step 3: Configure the Communication Card as Part of the Project

Use RSLogix 5000 software to add the communication card as part of the SoftLogix project. In the Controller Organizer, add the communication card to the I/O Configuration folder as outlined below.

You should already have added the SoftLogix controller to the project. See [Step 1: Create and Configure the Controller in the SoftLogix Chassis Monitor on page 27.](#)

Your controller is offline.

1. In RSLogix 5000 software, in the I/O Configuration folder, right-click the Backplane of the 1789-L60 SoftLogix5860 controller and choose New Module.

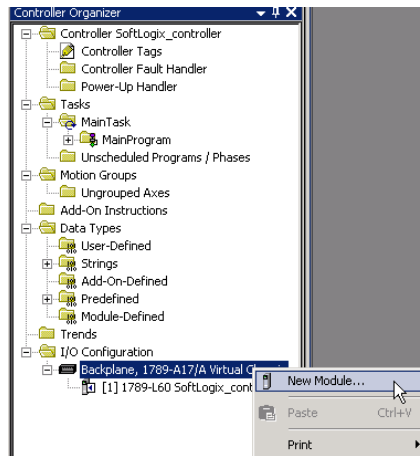

The Select Module dialog box appears.

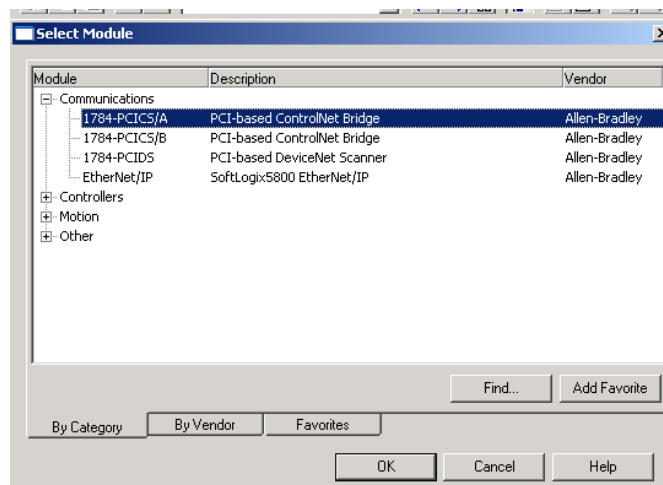

2. Expand the Communications list and choose the 1784-PCICS communication card that matches your module.

In this example, we chose the 1784-PCICS/A card.



3. Click OK.

The Major Revision dialog box appears.

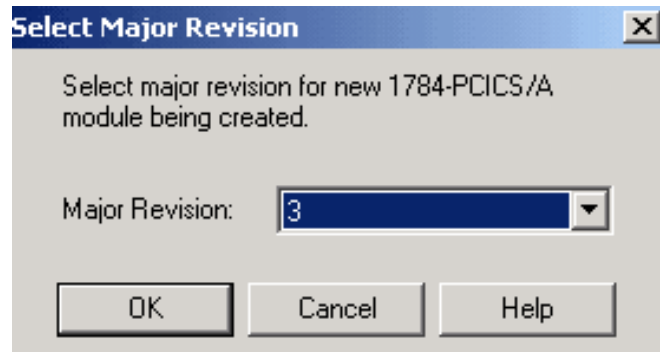

4. Choose the Major Revision number that matches your module and click OK.

The New Module dialog box appears.

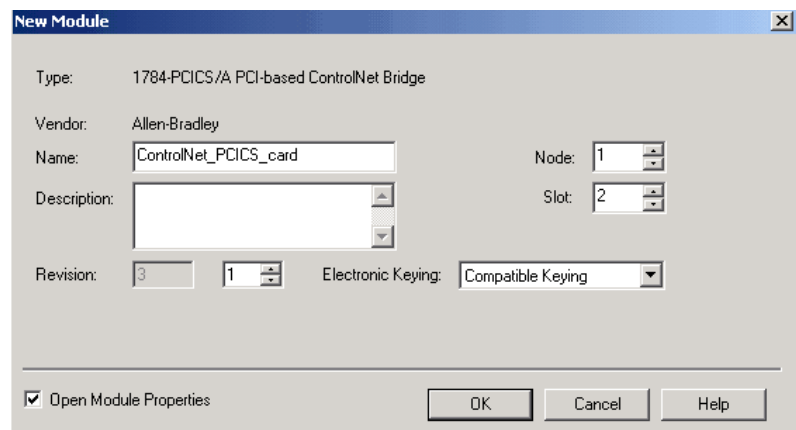

5. Name the module and choose the slot number.

Our example uses slot 2. (The slot number must be the same number you assigned the module to in the SoftLogix Chassis Monitor).

6. Click OK.

The Module Properties dialog box appears.

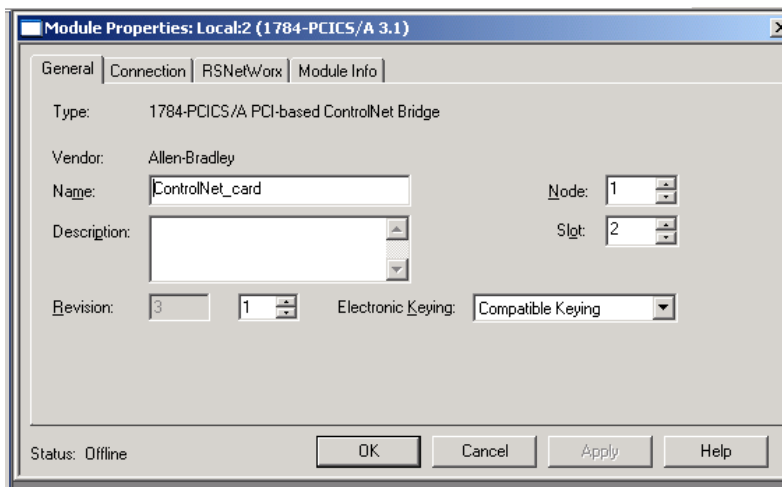

7. In the Module Properties dialog box, click each tab and choose the settings for the module.

Tab	Definition
General	<p>On this tab, you can view the following information:</p> <ul style="list-style-type: none"> <li>Type and description of the module being created.</li> <li>Vendor of the module being created.</li> <li>Status the controller has about the module (only while online).</li> </ul> <p>The tab also lets you enter the following information:</p> <ul style="list-style-type: none"> <li>Name of the module.</li> <li>Description for the module.</li> <li>Slot number where the module resides.</li> <li>Minor revision information for the module.</li> <li>An electronic keying option (not used for SoftLogix).</li> </ul>
Connection	<p>Use this tab to define controller-to-module behavior. On this tab, you can perform the following actions:</p> <ul style="list-style-type: none"> <li>Choose a requested packet interval.</li> <li>Choose to inhibit the module.</li> <li>Configure the controller so that a loss of connection to this module causes a major fault.</li> <li>View module faults.</li> </ul> <p>The data on this tab comes directly from the controller. This tab displays information about the condition of the connection between the module and the controller.</p> <p>Use this tab to do the following:</p> <ul style="list-style-type: none"> <li>Launch RSNetWorx for ControlNet software to view and edit the respective network.</li> <li>Associate a ControlNet project file with the respective module.</li> <li>Schedule a ControlNet network.</li> </ul>
RSNetWorx	<p>Use this tab to do the following:</p> <ul style="list-style-type: none"> <li>Launch RSNetWorx for ControlNet software to view and edit the respective network.</li> <li>Associate a ControlNet project file with the respective module.</li> <li>Schedule a ControlNet network.</li> </ul>
Module Info	<p>The Module Info tab of the Module Properties dialog box displays read-only information about the selected module.</p>

**8.** Click OK.

---

**IMPORTANT** The virtual backplane driver must be installed via RSLinx software before you can download a project to the SoftLogix controller. Even if you plan to remotely program the controller over a ControlNet or Ethernet network, you must add the virtual backplane driver via RSLinx software. If you do not, persistent storage will not function and when you restart the computer, the controller will come up with cleared memory (the program will not get reloaded).

---

## Step 4: Add Remote Communication Devices for the Communication Card

Complete your system configuration by adding the remote communication devices and appropriate I/O modules to your project. Follow these steps.

1. In RSLogix 5000 software, from the Controller Organizer, right-click the 1784-PCICS communication card you added, then choose New Module to add a ControlNet Adapter.

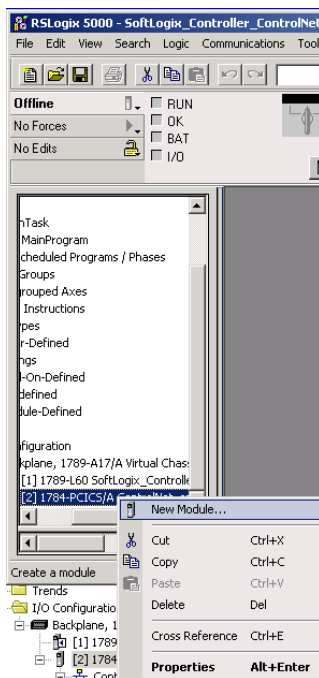

The Select Module dialog box appears.

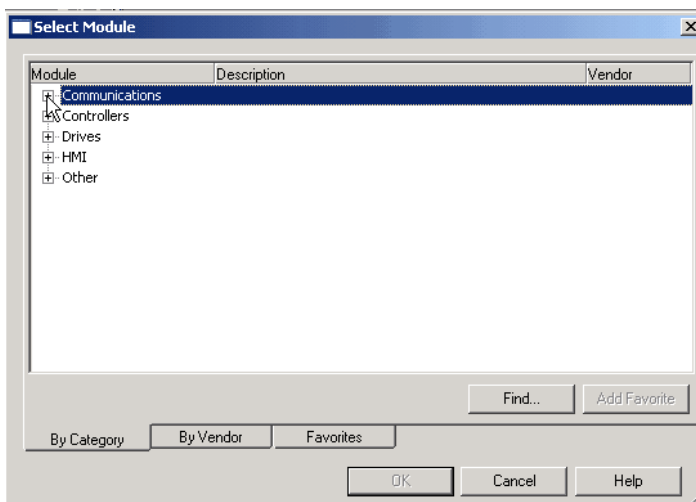

2. Expand the Communications list.

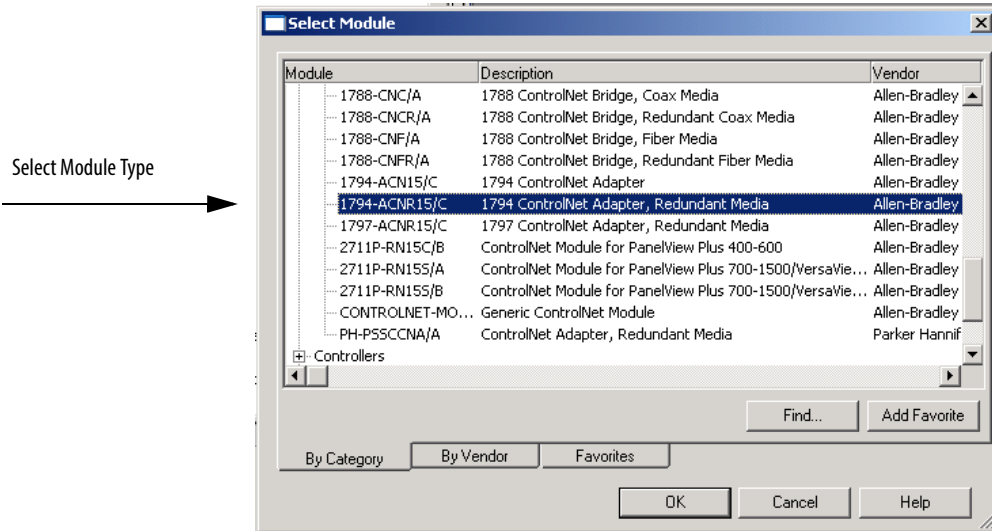

3. Choose the module type.

The 1794-ACNR15/C 1794 ControlNet Adapter, Redundant Media is shown in this example.

4. Click OK.

The Major Revision dialog box appears.

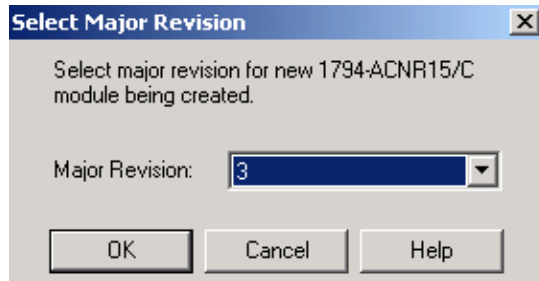

5. Choose the revision number and click OK.

The New Module Properties dialog box appears.

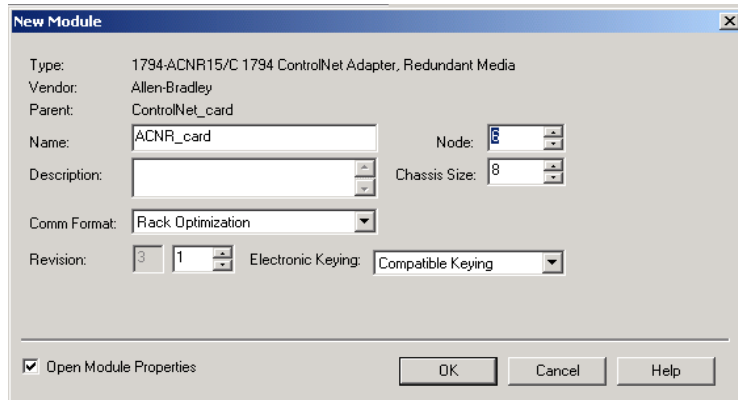

6. In the Module Properties dialog box, name the adapter and choose the appropriate communication settings.
7. Choose the Open Module Properties box.
8. Click OK.

The Module Properties dialog box for the remote module appears.

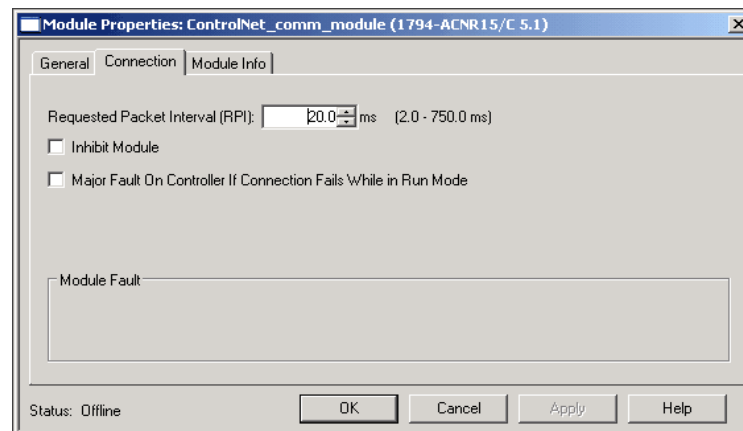
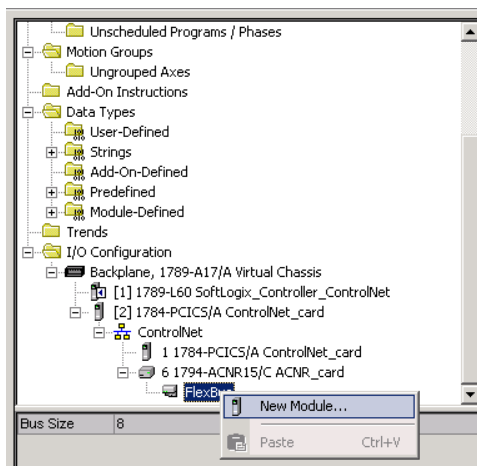

**Table 10 - Module Properties Dialog Box Tab Descriptions**

Tab	Definition
General	<p>On this tab, you can do the following:</p> <ul style="list-style-type: none"> <li>• View the module catalog number and description of the module being created.</li> <li>• View the vendor of the module being created.</li> <li>• View the name of the parent module.</li> <li>• Enter the name of the module.</li> <li>• Enter a description of the module.</li> <li>• Choose the desired communication formats: non-I/O modules.</li> <li>• Specify a minor revision number for the module.</li> <li>• Specify a node.</li> <li>• Specify a chassis size.</li> <li>• Choose an electronic keying option (not used for SoftLogix).</li> </ul>
Connection	<p>Use this tab to define controller-to-module behavior. On this tab, you can perform these actions:</p> <ul style="list-style-type: none"> <li>• Choose a requested packet interval</li> <li>• Choose to inhibit the module</li> <li>• Configure the controller so that a loss of connection to this module causes a major fault</li> <li>• View module faults</li> </ul> <p>The data on this tab comes directly from the controller. This tab displays information about the condition of the connection between the module and the controller.</p>
Module Info	<p>The Module Info tab of the Module Properties dialog box displays read-only information about the selected module.</p>

### Add and Configure I/O Modules for the Remote Communication Module

1. Add an input I/O module, right-click 1794-ACNR15/C adapter card in the I/O Configuration folder and choose New Module.



The Select Module dialog box appears.

2. Expand the Digital list.

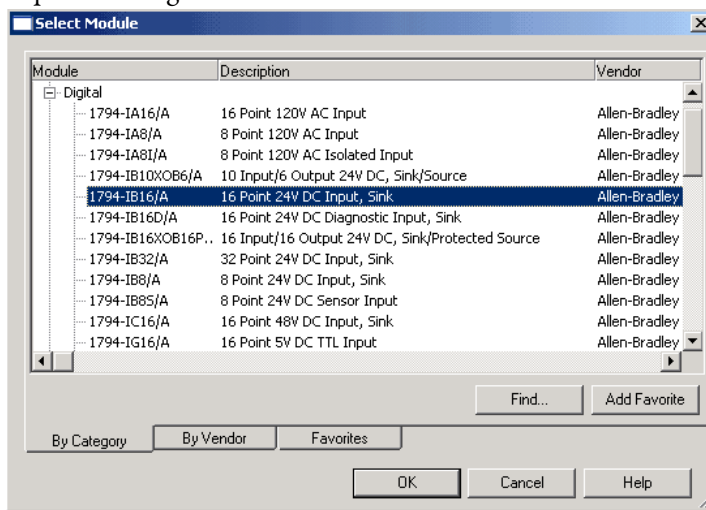

3. Select the input module and click OK.

For this example, we chose the 1794-IB16/A 16 Point 24V DC Input, Sink module.



The New Module dialog box appears.

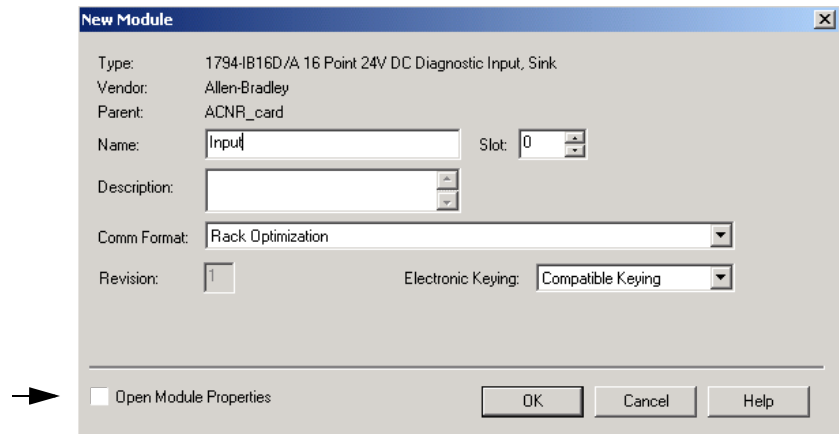

4. Enter the module name and slot number.
5. Make sure the Open Module Properties box is unchecked.
6. Click OK.
7. Add an output I/O module, right-click 1794-ACNR15/C adapter card in the I/O Configuration folder and choose New Module.

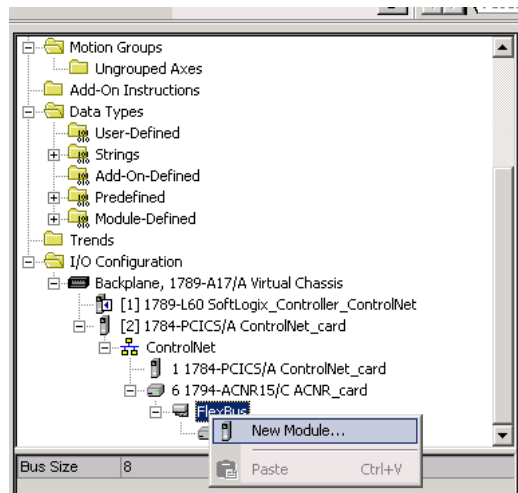

The Select Module dialog box appears.

8. Expand the Digital list.

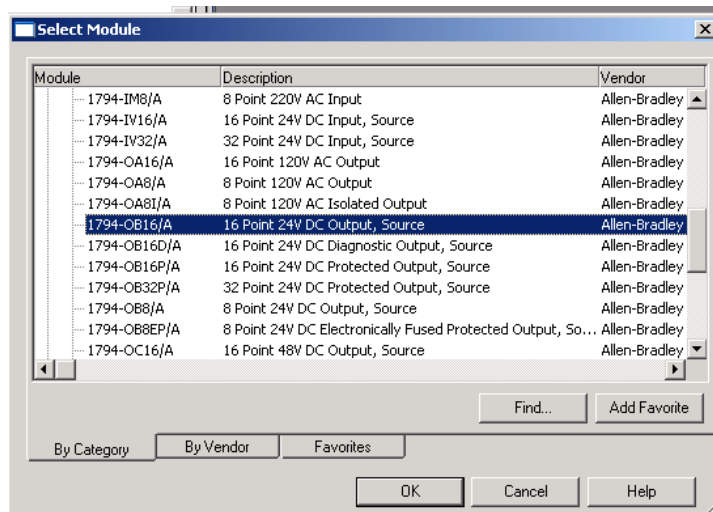

9. Select the output module and click OK.

For this example, we chose the 1794-OB16/A 16 Point 24V DC Output, Source module.

The New Module dialog box appears

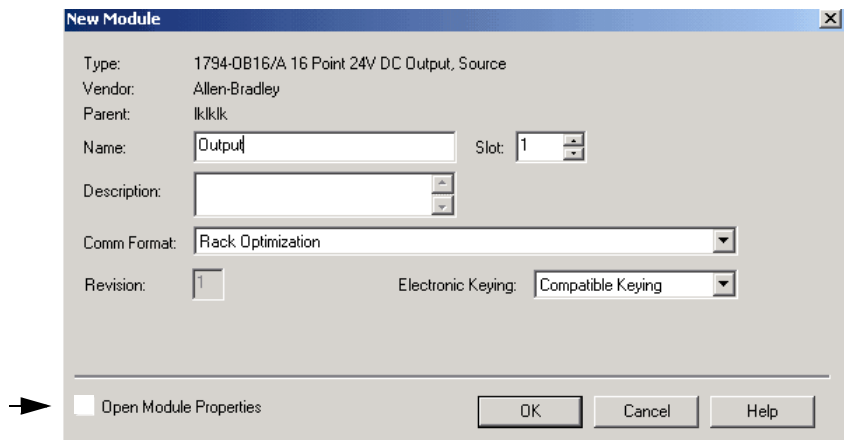

10. Enter the module name and slot number. Make sure the Open Module Properties box is unchecked.

11. Click OK.

Continue to add and configure I/O modules for the remote communication module by adding them as we did in [step 1](#) on [page 204](#).

See the ControlNet Network Configuration User Manual, publication [CNET-UM001](#), for more information.

12. From the File menu, choose Save to save the project.

## Step 5: Download the Project to the Controller

1. From the Communications menu, choose Who Active.

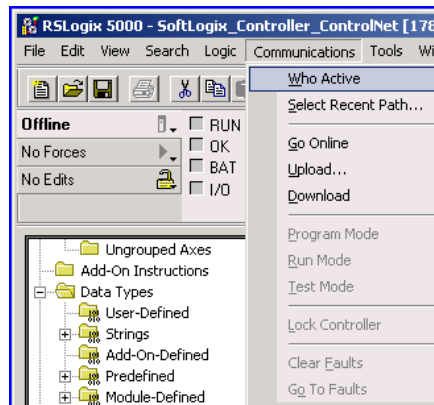

The Who Active dialog box appears.

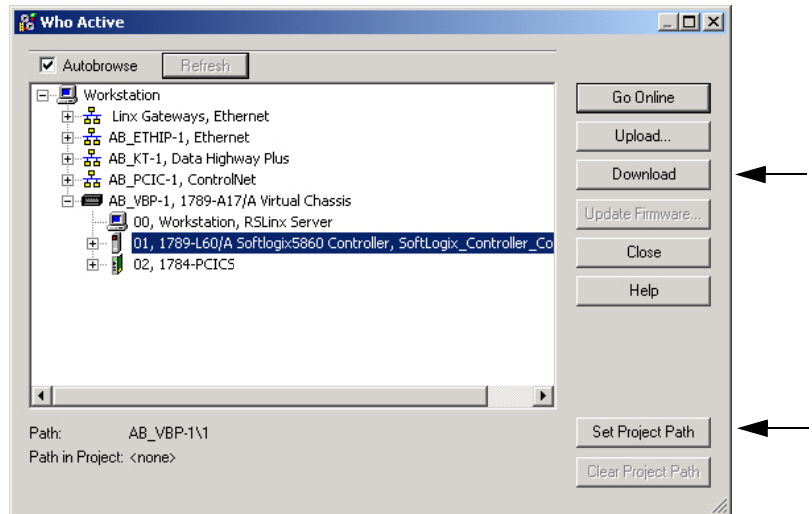

2. Browse to the SoftLogix controller.
3. Click Set Project Path button to cause this controller's path to be saved as part of the .acd and will link the .acd project with this path to the controller.
4. Click Download.

The Download dialog box appears.

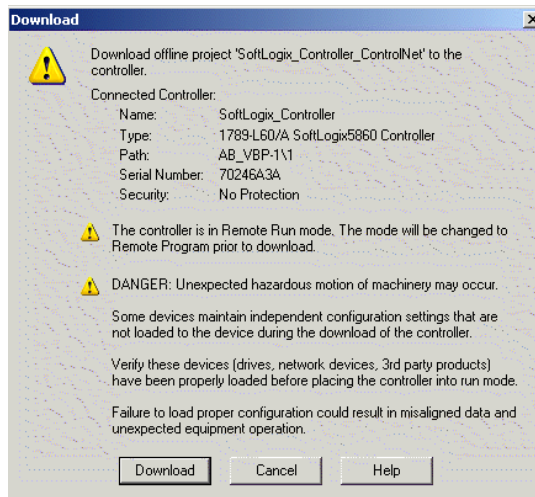

5. Click Download on the Download dialog box.

This will download the .acd project into the controller and put you online with the controller.

## Step 6: Schedule the Network

Use RSNetWorx software to schedule the ControlNet network. The controller project must already be downloaded from RSLogix 5000 software to the controller and the controller must be in Program or Remote Program mode. For more detailed information, see the RSNetWorx for ControlNet Getting Results Guide, publication [CNET-GR001](#).

These steps describe how to schedule the network.

1. Launch RSNetWorx for ControlNet software.

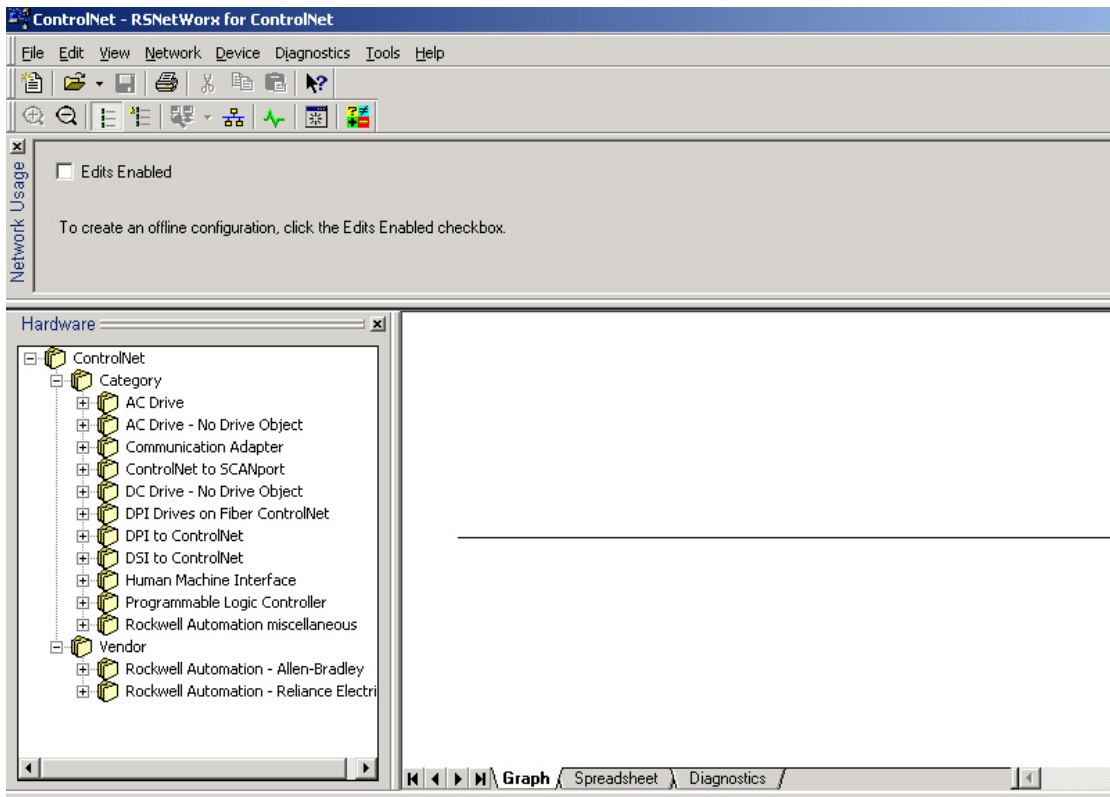

2. From the Network menu, choose Online to go online and survey the network.

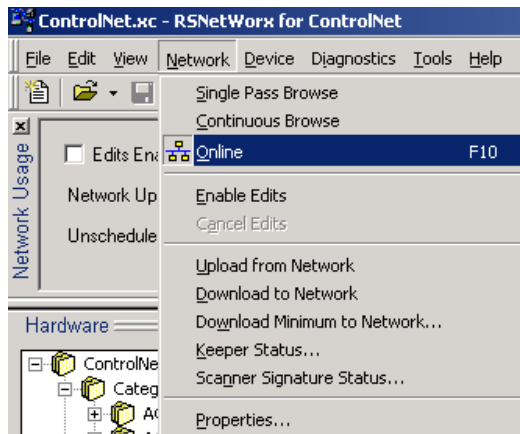

The Network Browser dialog box appears.

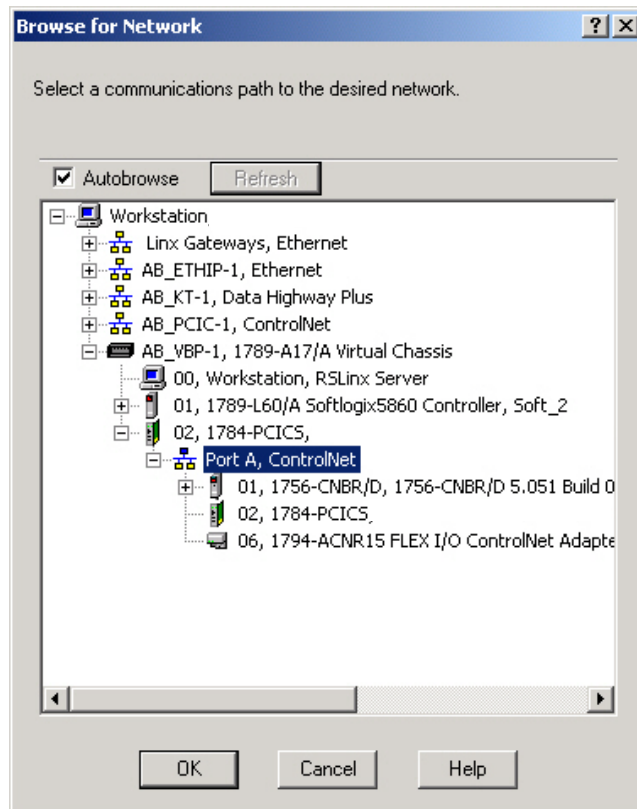

3. Browse to the desired ControlNet Network and select the network.
4. Click OK.

The network window appears.

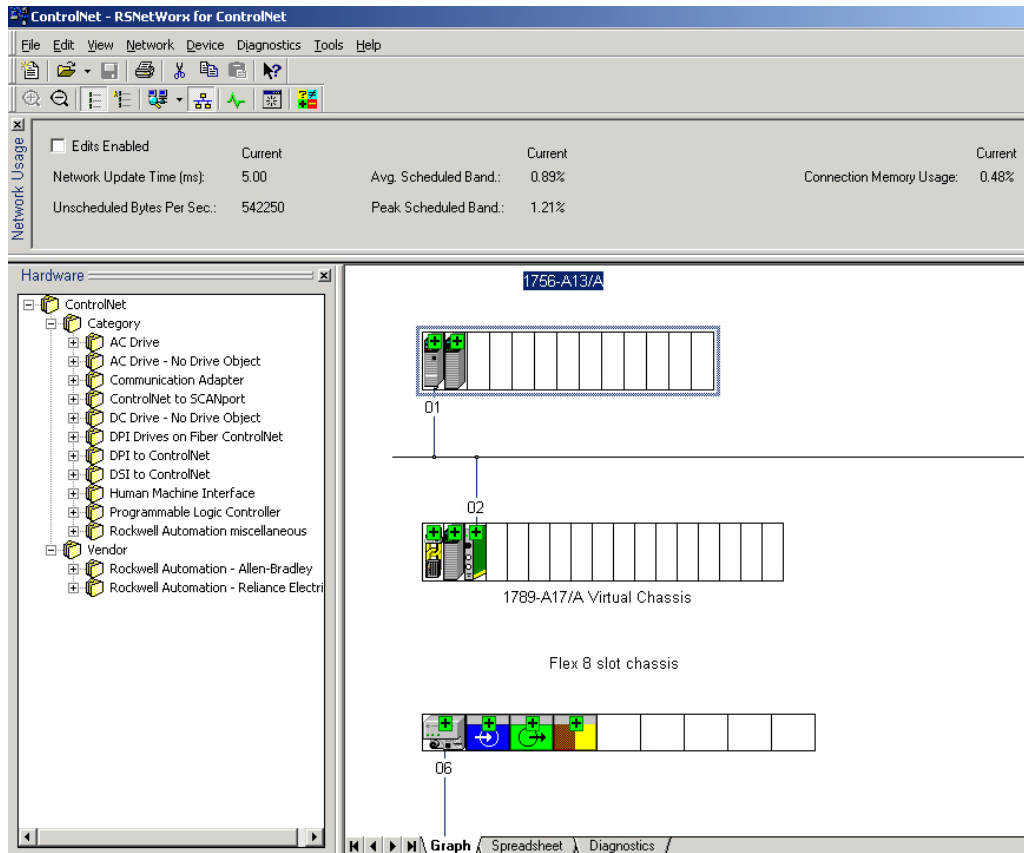

5. Click Edits Enabled.

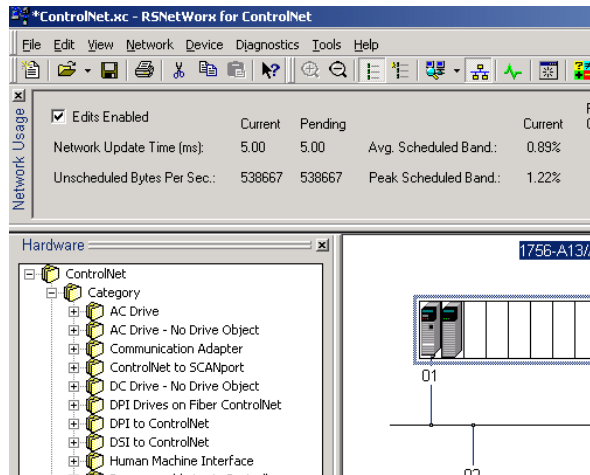

- From the Network menu, choose Properties to set the network's properties.

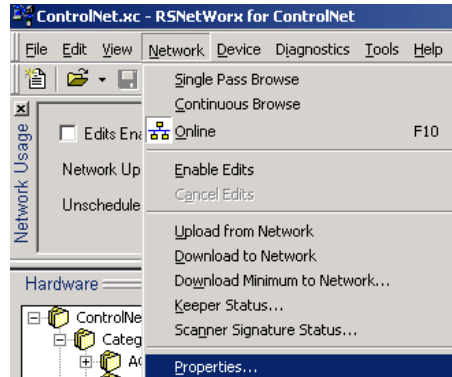

The Network Properties dialog box appears.

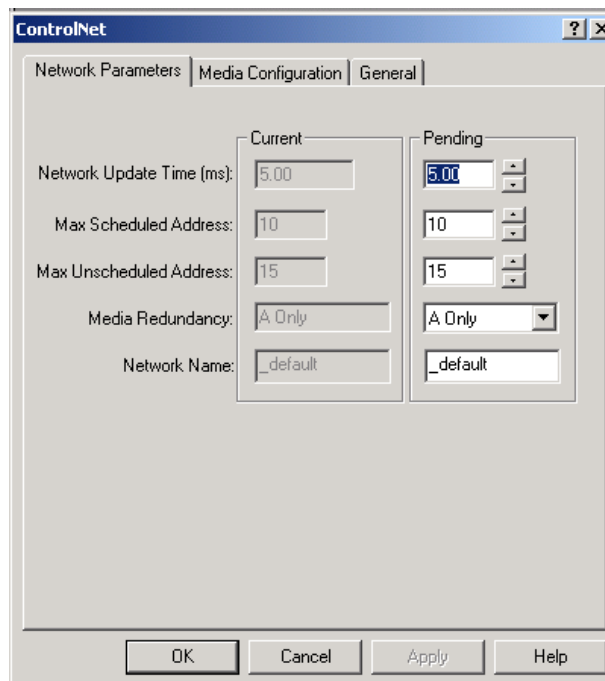

Tab	Description
Network Parameters	On the Network Parameters tab, you can view the current configuration parameters associated with your ControlNet network. In addition, with the Edits Enabled checkbox selected, you can modify the network configuration parameters, including the network update time, maximum scheduled address, maximum unscheduled address, media redundancy, and the network name.
Media Configuration	On the Media Configuration tab, you configure your physical media to optimize data transmission across your ControlNet network. With the Edits Enabled checkbox selected, you can modify the worst case, end-to-end network hardware allocations and specify values for the media components associated with your ControlNet network configuration.
General	On the General tab, you can view high-level properties of your ControlNet network. In addition, you can modify the properties of your ControlNet network, including name, description, and online path.



- On the Network Parameters tab, specify the network update time (NUT).

The default NUT is 5 ms. The NUT you specify must be lower than or equal to the lowest RPI in your system.

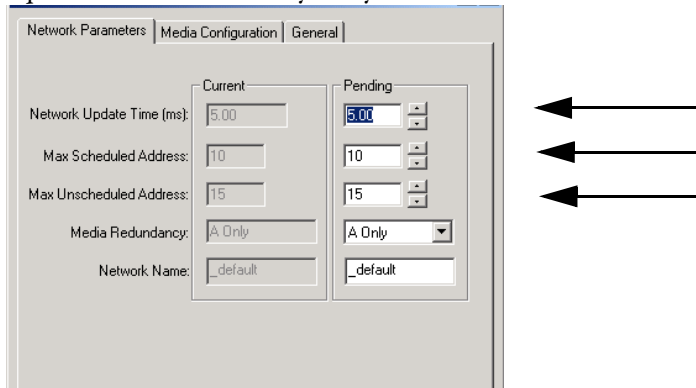

- Enter the Pending Max Scheduled Address and Pending Max Unscheduled Address.
- Click Apply to save the information you entered.
- Click the Media Configuration tab.

The Media Configuration tab appears.

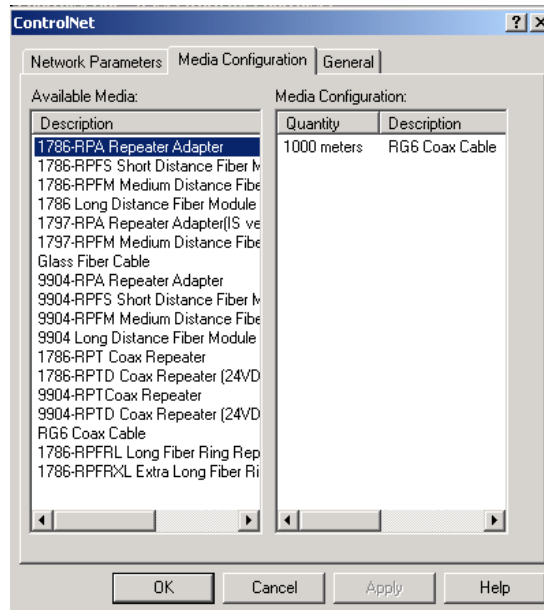

- Enter data on the media tab to match your system.
- Click OK.

- In RSNetWorx software, from the File menu, choose Save to save the network.

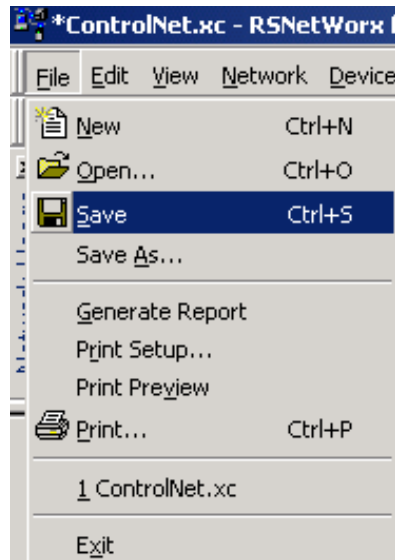

The Save As dialog box appears.

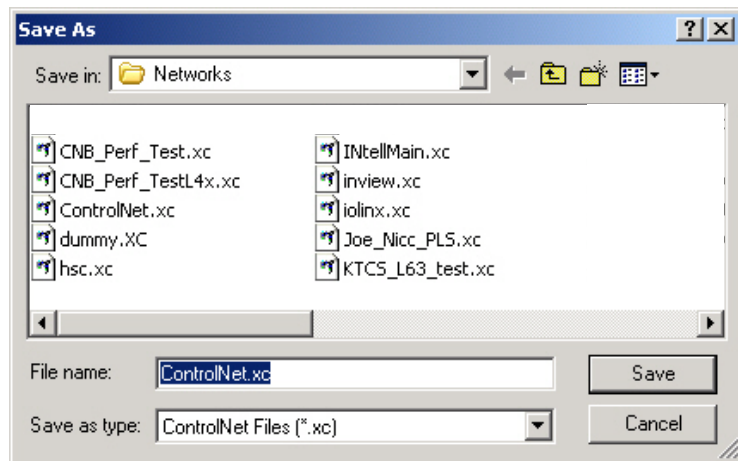

- Name the file and click Save.

The Save Configuration dialog box appears.

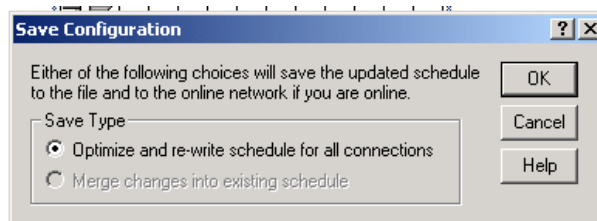

- Click Optimize and re-write schedule for all connections.

16. Click OK.

**IMPORTANT** Every device on the network must be in Program or Remote Program mode for the software to rewrite all of its connections. If a device is not in the correct mode, the software prompts you to let it change the device's mode.

## ControlNet I/O Data

The SoftLogix controller supports as many communication cards as you have PCI slots in the computer.

Each Logix-based communication module supports a limited number of scheduled and unscheduled connections. The 1784-PCICS SoftLogix ControlNet communication module has a maximum of 127 scheduled connections and 128 unscheduled connections.

The I/O information is presented as a structure of multiple fields, which depend on the specific features of the I/O module. The name of the structure is based on the location of the I/O module in the system. Each I/O tag is automatically created when you configure the I/O module through the programming software. Each tag name follows this format:

Location:SlotNumber:Type.MemberName.SubMemberName.Bit

Address Variable	Description
Location	Identifies network location. ADAPTER_NAME = identifies remote adapter or bridge device.
SlotNumber	Slot number of I/O module in its chassis.
Type	Type of data: I = input O = output C = configuration S = status
MemberName	Specific data from the I/O module; depends on the type of data the module can store. For example, Data and Fault are possible fields of data for an I/O module. Data is the common name for values that are sent to or received from I/O points.
SubMemberName	Specific data related to a MemberName.
Bit (optional)	Specific point on the I/O module; depends on the size of the I/O module (0...31 for a 32-point module).

### EXAMPLE

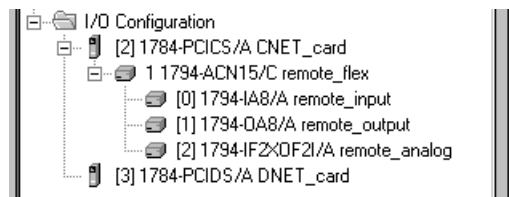

The tags created for the remote device (1794-ACN15 in this example) depend on the communication format you choose for that device when you add the device to the I/O Configuration folder.

If you choose	The automatically-created tags are for a
Rack optimization	rack-optimized connection to the remote communication device.
Listen-only-rack optimization	rack-optimized connection to the remote communication device. (not available on all communication devices)
None	direct connection to the individual I/O modules with no connection to the remote communication device.

### Rack-optimized Connections

The rack-optimized connection creates a DINT element for each possible I/O module connected to the device ‘remote\_flex.’ The array remote\_flex:I.Data contains the possible input elements; the remote\_flex:O.Data contains the possible output elements.

[-] remote_flex:I				AB:1794_ACN15_8SLOT:I:0	
[+] remote_flex:I.SlotStatusBits				DINT	Binary
[-] remote_flex:I.Data				INT[8]	Binary
[+] remote_flex:I.Data[0]				INT	Binary
[+] remote_flex:I.Data[1]				INT	Binary
[+] remote_flex:I.Data[2]				INT	Binary
[+] remote_flex:I.Data[3]				INT	Binary
[+] remote_flex:I.Data[4]				INT	Binary
[+] remote_flex:I.Data[5]				INT	Binary
[+] remote_flex:I.Data[6]				INT	Binary
[+] remote_flex:I.Data[7]				INT	Binary
[-] remote_flex:O				AB:1794_ACN15_8SLOT:O:0	
[+] remote_flex:O.Data				INT[8]	Binary
[+] remote_flex:O:I	remote_flex:I.Data[0]	remote_flex:I.Data[0]		INT	Binary
[+] remote_flex:O:C				AB:1794_DI_Delay8:C:0	
[+] remote_flex:O:1	remote_flex:O.Data[1]	remote_flex:O.Data[1]		INT	Binary
[+] remote_flex:O:2				AB:1794_DO8:C:0	
[+] remote_flex:O:2:I				AB:1794_IF2xOF2:I:0	
[+] remote_flex:O:2:O				AB:1794_IF2xOF2:O:0	
[+] remote_flex:O:2:C				AB:1794_IF2xOF2:C:0	

The tags for the individual, digital I/O modules are actually alias tags backed into the rack-optimized array tag. For example, ‘remote\_flex:O:I’ is an alias tag to ‘remote\_flex:I.Data[0].’ These digital I/O modules were configured with a rack-optimized communication format to take advantage of the rack-optimized array tag created for the communication device.

The index number on the array element refers to the slot number on ‘remote\_flex.’ For example, Data[2] refers to the module in slot 2. You can have only one I/O module in a given slot, so Data[2] is used only in either the input or output array. That same element in the other array still exists even though it does not contain actual data. You can create alias tags for the elements you actually use to more readily identify the data you need.

Note that the tags for the analog module ('remote\_flex:2:I', 'remote\_flex:2:O', and 'remote\_flex:2:C') are not alias tags.

---

**IMPORTANT** Analog modules require direct connections to operate. Do not use the element of the rack-optimized array tag to control the analog module. Use the individual, slot-referenced tag.

---

### Direct Connections

If you choose None for the communication format to the communication device, the software assumes that you want a direct connection for each I/O module connected to that device. The software creates slot-referenced tags for each I/O module, but not for the communication device.

	remote_flex:0:I			AB:1794_DI_8:I:0	
	+ remote_flex:0:I.Fault			DINT	Binary
	+ remote_flex:0:I.Data			SINT	Binary
	+ remote_flex:0:C			AB:1794_DI_Delay8:C:0	
	+ remote_flex:1:I			AB:1794_DO:I:0	
	remote_flex:1:O			AB:1794_DO8:O:0	
	+ remote_flex:1:O.Data			SINT	Binary
	+ remote_flex:1:C			AB:1794_DO8:C:0	
	+ remote_flex:2:I			AB:1794_IF2XOF2:I:0	
	+ remote_flex:2:O			AB:1794_IF2XOF2:O:0	
	+ remote_flex:2:C			AB:1794_IF2XOF2:C:0	

### Example 1: SoftLogix Controller and ControlNet I/O

In this example, one SoftLogix controller controls I/O modules through a 1794-ACN15 module.

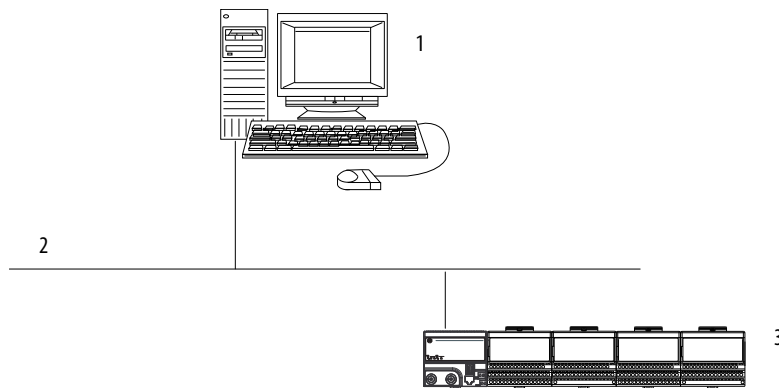

Item	Description
1	SoftLogix controller
2	ControlNet network
3	1784-ACN15 module with I/O (remote FLEX™ I/O)

### Controlling I/O Modules

This example has the SoftLogix controller controlling the I/O modules connected to the remote 1794-ACN15 module. The data the SoftLogix controller receives from the I/O modules depends on how you configure the I/O modules. You can configure each module as a direct connection or as a rack-optimized connection. One location (chassis or DIN rail) can have a combination of some modules configured as a direct connection and others as rack optimized.

### Total Connections Required by the SoftLogix Controller

This table calculates the connections used in this example.

Connection	Amount
SoftLogix controller to 1784-PCICS card.	0
SoftLogix controller to remote 1794-ACNR15 module (communication format is 'none').	0
SoftLogix controller to four I/O modules. (through 1794-ACNR15) All four module types (discrete and analog) can be configured as direct connections.	4
<b>Total Connections Used: 4</b>	

If you configure the 1794-ACNR15 module as rack-optimized and the I/O modules as rack-optimized, you use only one connection to the 1794-ACN15 module, reducing the above example by three connections. This table calculates the connections for this rack-optimized configuration.

Connection	Amount
SoftLogix controller to 1784-PCICS card	0
SoftLogix controller to remote 1794-ACNR15 module (communication format is 'rack optimization').	1
SoftLogix controller to four discrete I/O modules (through module 1794-ACNR15) All four modules configured as rack-optimized connections. Only discrete modules can be configured as rack-optimized connections.	0
<b>Total Connections Used: 1</b>	

## Example 2: SoftLogix Controller to SoftLogix Controller

In this example, one SoftLogix controller communicates with another SoftLogix controller over the ControlNet network. The two controllers can be in separate computers or in the same computer.

Example	Illustration
Each SoftLogix controller resides in its own computer.	
Each SoftLogix controller resides in the same computer.	

## Send a MSG Instruction

To send an MSG from Soft1 to Soft2, follow these steps.

1. For Soft1, create a controller-scoped tag and choose the Message data type.
2. Enter an MSG instruction.

In this example logic, a message is sent when a specific condition is met. When count\_send is set, send count\_msg.



3. Configure the MSG instruction on the Configuration tab.

For this item	Specify
Message Type	CIP Data Table Read or CIP Data Table Write
Source Tag	Tag containing the data to be transferred
Number of Elements	Number of array elements to transfer
Destination Tag	Tag to which the data will be transferred

4. On the Communication tab, specify the communication path.

A communication path requires pairs of numbers. The first number in the pair identifies the port from which the message exits. The second number in the pair designates the node address of the next device.

Item	Specify
Communication Path (each SoftLogix controller resides in its own computer)	1,2,2,27,1,5 Where: 1 is the SoftLogix backplane of Soft1 2 is 1784-PCICS card in slot 2 2 is the ControlNet port 27 is the ControlNet node of Soft2 1 is the SoftLogix backplane of Soft2 5 is the controller slot of Soft2
Communication Path (each SoftLogix controller resides in the same computer)	1,5 Where: 1 is the SoftLogix backplane of Soft1 5 is the controller slot of Soft2

**IMPORTANT** Ladder-triggered messages use the unscheduled portion of ControlNet bandwidth and will work without rescheduling the network.



## Produce and Consume Tags

You can produce a base tag, alias tag, or consumed tag. Produced data can be the following:

- A tag of DINT or REAL data type
- An array of DINT or REAL elements
- A user-defined structure with any type of elements. Use a user-defined structure to group BOOL, SINT, and INT data

The consumed tag must have the same data type as the produced tag in the originating controller. The controller performs type checking to be sure proper data is being received.

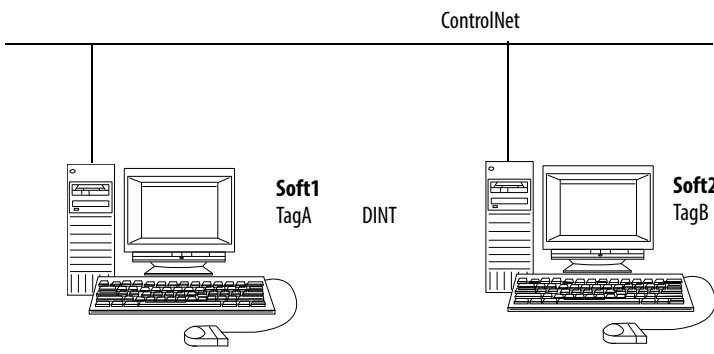
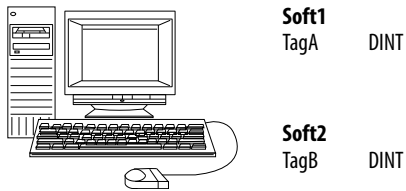
Example	Illustration
Each SoftLogix controller resides in its own computer	 <p style="text-align: center;">ControlNet</p> <p>The diagram shows a horizontal line representing the ControlNet network. Two vertical lines connect this network to two separate computer workstations. The workstation on the left is labeled 'Soft1 TagA DINT' and the workstation on the right is labeled 'Soft2 TagB DINT'. Each workstation includes a monitor, keyboard, and mouse.</p>
Each SoftLogix controller resides in the same computer, by using different CPUs	 <p>The diagram shows a single computer workstation with a monitor, keyboard, and mouse. To the right of the workstation, two SoftLogix controller icons are shown. The top one is labeled 'Soft1 TagA DINT' and the bottom one is labeled 'Soft2 TagB DINT'.</p>

This example shows two controllers in the project. The Soft1 controller produces TagA and the Soft2 controller consumes TagA and stores it as TagB.

1. To add two controllers in the I/O tree named Soft1 and Soft2, right-click I/O Configuration and choose New Module.
2. Name and configure each controller.

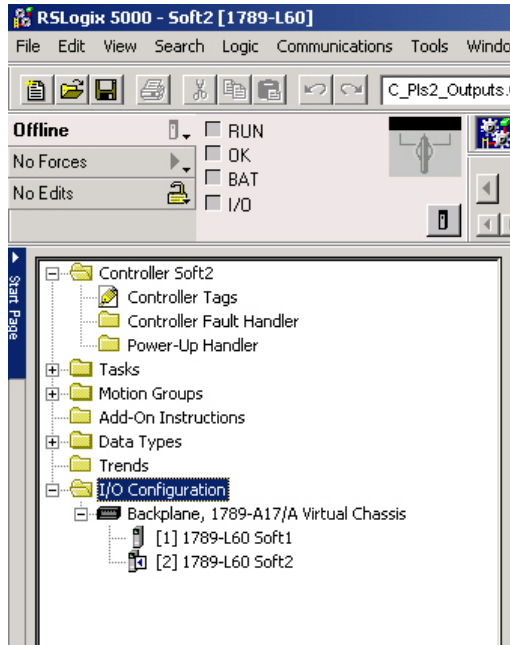

3. Create TagA for Soft1 controller. Enter the Name, Type and Data Type. Click OK.

TagA will look as follows.

Soft1 Controller - Produces TagA

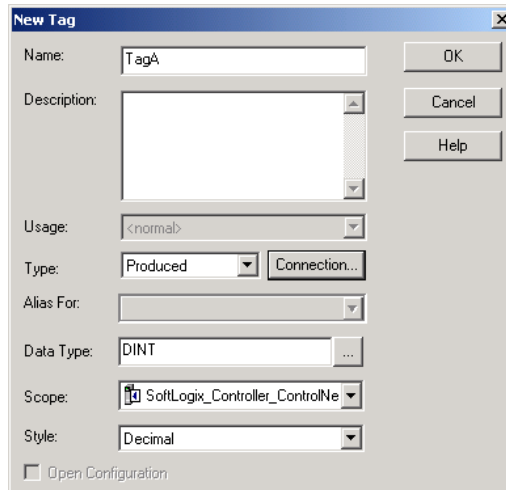

	P	Tag Name	Alias For	Base Tag	Type	Style
	<input checked="" type="checkbox"/>	+ TagA			DINT	Decimal

4. Create TagB for Soft2 controller.
5. Enter the Name, Type and Data Type.

6. Click Connection to complete creating TagB.

Soft2 Controller - Consumes TagA and Stores it in TagB

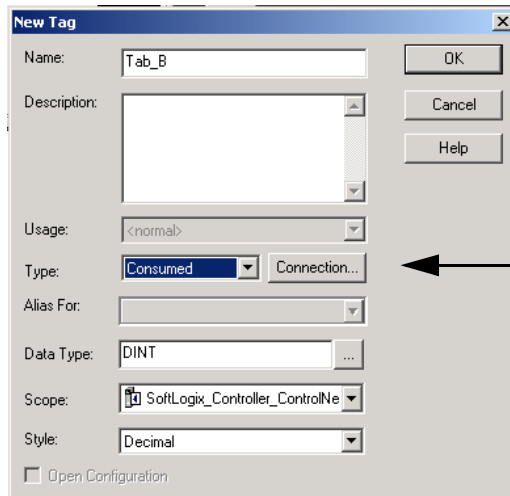

	P	Tag Name	Alias For	Base Tag	Type	Style
	<input type="checkbox"/>	+ TagB		Soft1:TagA	DINT	Decimal

The Consumed Tag Connection dialog box appears.

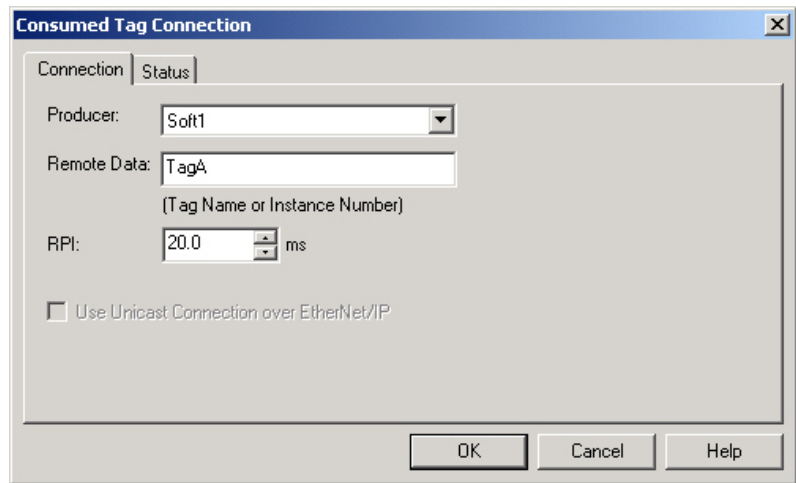

7. Enter the Producer controller's name (Soft1) in the Producer field and the tag to be consumed (TagA) in the Remote Data field and click OK.

For more detailed information on how to create Produced/Consumed tags, see Logix5000 Controllers Produced and Consumed Tags Programming Manual, publication [1756-PM011](#).

---

**IMPORTANT** Produced/Consumed tags can be created only offline and use the Scheduled portion of ControlNet bandwidth. After creating and downloading these tags, the network must be rescheduled.

---

Each produced tag requires one connection for the producing controller and an additional connection for each consuming controller. Each consumed tag requires one connection.

### Total Connections Required by the Soft1 Controller

This table calculates the connections used in this example.

Connection	Amount
Soft1 controller to 1784-PCICS card	0
Soft1 controller to remote 1784-PCICS card	0
Connected, cached MSG from Soft1 to Soft2	1
Produced TagA	
Produced from Soft1 to Soft2	1
Other consumer (2 are configured)	1
Consumed TagB	1
<b>Total Connections Used: 4</b>	

### Example 3: SoftLogix Controller to Other Devices

This example, one SoftLogix controller communicates with other controllers over the ControlNet network.

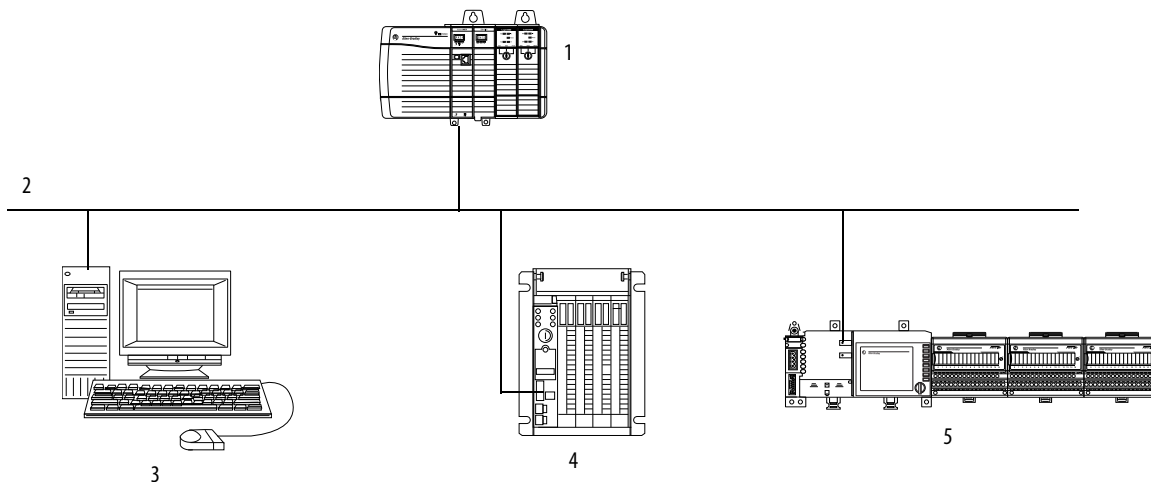

Item	Description
1	ControlLogix controller (Control1)
2	ControlNet network
3	SoftLogix controller (Soft1)
4	PLC-5 controller (PLC5C1) for the ControlNet network
5	FlexLogix™ controller (Flex1)

## Send a MSG Instruction

You configure an MSG instruction to a ControlLogix and FlexLogix controller the same as you do for a SoftLogix controller. All Logix-based controllers follow the same MSG configuration requirements. Configuring an MSG instruction for a PLC-5 controller depends on the originating controller.

For MSG instructions originating from the SoftLogix controller to the PLC-5 controller for the ControlNet network, follow these guidelines.

Type of Logix MSG Instruction	Source	Destination
PLC-5 Typed Read	Any integer element (such as B3:0, T4:0.ACC, C5:0.ACC, N7:0, and so forth)	SINT, INT, or DINT tag
	Any floating point element (such as F8:0, PD10:0.SP, and so forth)	REAL tag
PLC-5 Typed Write	SINT or INT tag	Any integer element (such as B3:0, T4:0.ACC, C5:0.ACC, N7:0, and so forth)
	REAL tag	Any floating point element (such as F8:0, PD10:0.SP, and so forth)
PLC-5 Word Range Read	Any data type (such as B3:0, T4:0, C5:0, R6:0, N7:0, F8:0, and so forth)	SINT, INT, DINT, or REAL
PLC-5 Word Range Write	SINT, INT, DINT, or REAL	Any data type (such as B3:0, T4:0, C5:0, R6:0, N7:0, F8:0, and so forth)

The PLC-5 controller supports logical ASCII addressing. Place the SoftLogix tag name in double quotes (“”).

Type of PLC-5 MSG Instruction	Source	Destination
PLC-5 Typed Write to SoftLogix	Source element	<i>N7:10</i>
	Destination tag	'array_1'
PLC-5 Typed Read from SoftLogix	Source tag	'array_1'
	Destination element	<i>N7:10</i>

**TIP** You can also do PLC-5 Typed Read and Writes messages to a Logix controller without using logical ASCII addressing by creating a PLC-5 compatibility file in the Logix controller for MSG instructions initiated by a PLC-5 controller.

## Produce and Consume Tags

You can produce and consume tags with any Logix controller the same as you do with a SoftLogix controller. All Logix controllers follow the same requirements for producing and consuming tags.

Producing and consuming tags with a PLC-5 controller for the ControlNet network depends on the type of data.

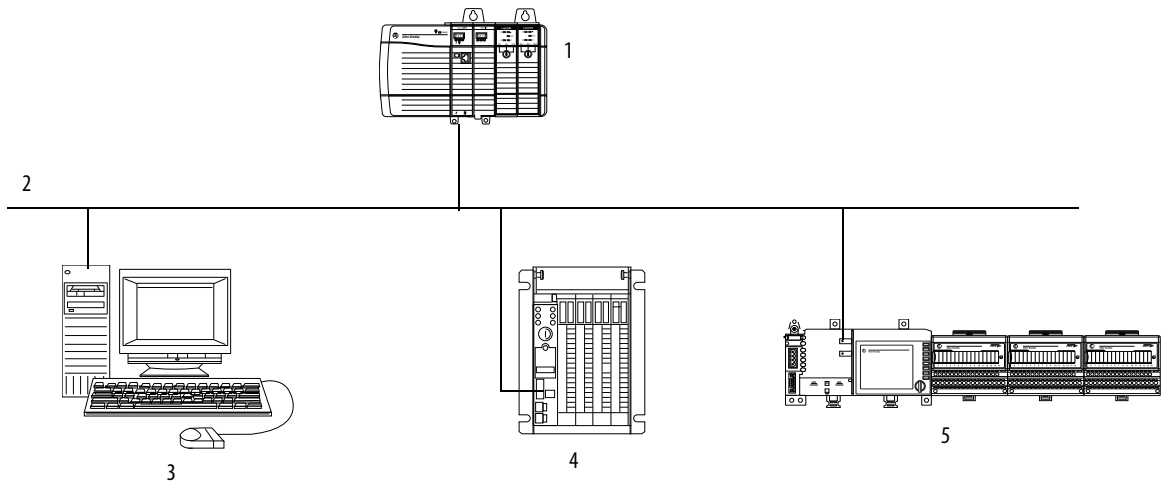

Item	Definition
1	ControlLogix controller (Control1)
2	ControlNet network
3	Soft1 TagA DINT TabB REAL
4	PLC-5 controller (PLC5C1) for the ControlNet network
5	FlexLogix controller (Flex1)

*Produce a Tag to a PLC-5 Controller for the ControlNet Network*

Complete these steps to produce a tag that a PLC-5 controller for the ControlNet network can consume.

1. Determine the type of data to produce..

<b>If</b>	<b>And you are producing</b>	<b>Then</b>
INT	N/A	Create a user-defined data type that contains an array of INTs with an even number of elements, such as INT[2]. When you produce INTs, you must produce two or more. Create a produced tag and choose the user-defined data type you created.
DINT or REAL	Only one DINT or REAL value	Create a produced tag and choose the DINT or REAL data type, as appropriate.
	More than one DINT or REAL	Create a user-defined data type that contains an array of DINTs or REALs, as appropriate. Create a produced tag and choose the user-defined data type you created.

2. In RSNetWorx software, open the ControlNet configuration for the target PLC-5 controller for the ControlNet network, insert a Receive Scheduled Message and enter the following Message size.

<b>If the produced tag contains</b>	<b>For the Message Size Enter</b>
INTs	The number of integers in the produced tag
DINTs	Two times the number of DINTs or REALs in the produced tag. For example, if the produced tag contains 10 DINTs, enter 20 for the Message size.
REALs	

3. In the RSNetWorx software, reschedule and save the network.

The PLC-5 controller for the ControlNet network does not perform type checking. Make sure the PLC-5 data type can correctly receive the SoftLogix produced tag to be sure proper data is being received.

When a PLC-5 controller for the ControlNet network consumes a tag that is produced by a Logix5000 controller, it stores the data in consecutive 16-bit integers. The PLC-5 controller stores floating-point data, which requires 32-bits regardless of the type of controller, as follows:

- The first integer contains the upper (left-most) bits of the value.
- The second integer contains the lower (right-most) bits of the value.

To reconstruct the floating point data within the PLC-5 controller, first reverse the order of the integers and then copy them to a floating-point file.

### Consume a Tag from a PLC-5 Controller for the ControlNet Network

Complete these steps to consume a tag from a PLC-5 controller for the controlNet network.

1. In RSNetWorx software, open the ControlNet configuration of the PLC-5 controller and insert a Send Scheduled Message.
2. In RSLogix 5000 software, add the PLC-5 controller to the Controller Organizer.
3. Create a user-defined data type that contains these members.

Data Type	Description
DINT	Status
INT[x], where 'x' is the output size of the data from the PLC-5 controller (If you are consuming only one INT, no dimension is required)	Data produced by a PLC-5 controller

4. Create a consumed tag with the following properties.

Tag Property	Type or Choose
Tag type	Consumed.
Controller	The PLC-5 for the ControlNet network that is producing the data.
Remote instance	The message number from the ControlNet configuration of the ControlNet PLC-5 controller.
RPI	A power of two times the NUT of the ControlNet network. For example, if the NUT is 5 ms, choose an RPI of 5, 10, 20, 40, and so forth.
Data type	The user-defined data type that you created.

5. In the RSNetWorx for ControlNet software, reschedule and save the network.



## Total Connections Required by the Soft1 Controller

This table calculates the connections used in this example.

Connection	Amount
Soft1 controller to 1784-PCICS card	0
Soft1 controller to remote 1756-CNB module	0
Soft1 controller to remote 1788-CNC card	0
Soft1 controller to remote PLC5C1	1
Connected, cached MSG from Soft1 to Control1	1
Connected, cached MSG from Soft1 to Flex1	1
Connected, cached MSG from Soft1 to PLC5C1	1
Produced TagA:	
Produced from Soft1 to Control1	1
Consumed by PLC5C1	1
Consumed TagB from Control1	1
<b>Total Connections Used:</b>	<b>7</b>

The remote 1756-CNB and 1788-CNC card are configured as 'none' for the communication format, so the SoftLogix controller would require a direct connection for any I/O modules connected to these devices that you want in the configuration for the SoftLogix controller.

## Example 4: Use the SoftLogix Controller as a Gateway

The SoftLogix controller supports bridging over a ControlNet network. Any SoftLogix MSG instruction that bridges one network has multiple pairs of numbers in its communication path. To construct a communication path, follow these steps.

1. Specify the port where the message exits.

For Port	Specify
Backplane port	1
DF1 port from the controller	2
ControlNet port from a communication card/module	
Ethernet port from a communication card/module	
DH+ port over channel A from a 1756-DHRIO module	
DH+ port over channel B from a 1756-DHRIO module	3

2. Specify the next device.

For Device	Specify
ControlLogix backplane	Slot number
DF1 network	Station address (0...254)
ControlNet network	Node number (1...99 decimal)
DH+ network	Node number (1...77 decimal)
Ethernet network	IP address

3. Repeat step 1 and step 2 until you specify the target device.

In the following illustration, the ControlLogix controller can remotely access a PanelView™ terminal over a ControlNet network. The SoftLogix Chassis Monitor resides on the computer. A SoftLogix controller is not required for the gateway—you only need a 1784-PCICS card for each ControlNet network.

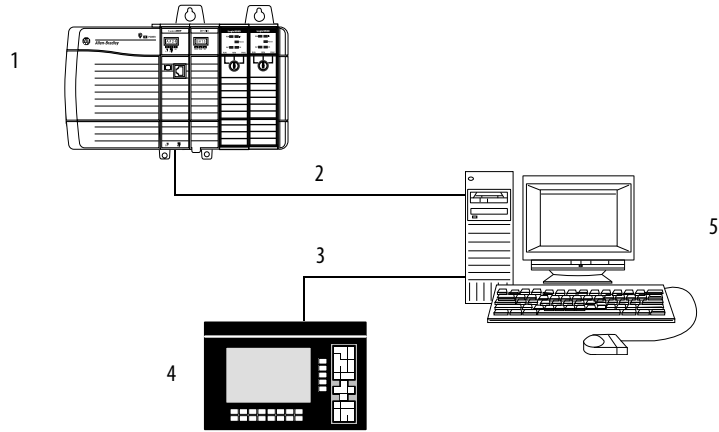

Item	Description
1	ControlLogix controller
2	ControlNet network 1
3	ControlNet network 2
4	PanelView terminal
5	The SoftLogix Chassis Monitor has two 1784-PCICS cards installed - one for each ControlNet network.

**Notes:**

## Program Virtual Motion

Topic	Page
Virtual Motion Overview	237
Logic for Motion Control	238
Considerations When Running a Motion Application in Windows Operating System	240

To set up virtual motion via a virtual axis in a SoftLogix system, you must install the following items:

- SoftLogix controller in the SoftLogix Chassis Monitor
- RSLogix 5000 software

---

**IMPORTANT** SoftLogix 5800 controllers and software do not support Integrated Motion on the EtherNet/IP network.

Windows Vista, Windows 2008, and Windows 7 Server operating system software do not support any motion modules in a SoftLogix system.

---

### Virtual Motion Overview

The SoftLogix controller supports virtual motion, allowing axis to be assigned on a virtual controller. For additional information on configuring a virtual axis, see the SERCOS and Analog Motion Configuration and Startup User Manual, publication [MOTION-UM001](#).

The configuration process varies, depending on your application and your drive selection.

1. Create a controller project by using RSLogix 5000 software.  
See [page 27](#).
2. Coordinate with system time.

Use CIP Sync to synchronize with a master clock. For more information, see the Integrated Architecture™ and CIP Sync Configuration Application Technique, publication [IA-AT003](#).

3. Add and configure the SERCOS interface module.

If you are not using a SERCOS interface module, you can still configure a virtual axis in RSLogix 5000 software.

Each ControlLogix controller can control up to 16 motion modules. Use one of the following SERCOS interface modules:

- 1756-M03SE
- 1756-M08SE
- 1756-M16SE

4. Add and configure a SERCOS drive.

You can create an axis when you are configuring the drive, or you can create it later.

Use the Kinetix® Motion Control Selection Guide, publication [GMC-SG001](#), to qualify and select the drive.

5. Create an axis and assign it to the Motion Group.
6. Configure the axis.

## Logic for Motion Control

The motion instructions operate on one or more axes. You must identify and configure axes before you can use them.

For more information on individual motion instructions, see the Logix5000 Controllers Motion Instruction Reference Manual, publication [MOTION-RM002](#).

Each motion instruction has an operand named Motion Control. This field uses a MOTION\_INSTRUCTION tag to store status information during the execution of motion instructions. This status information can include items such as instruction status or errors.

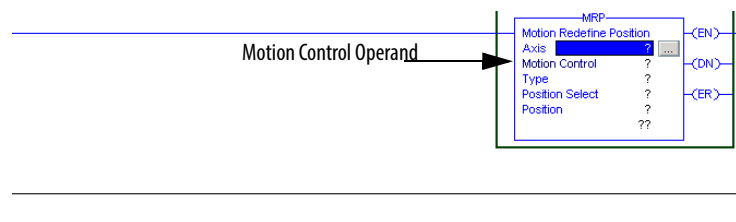

**ATTENTION:** Tags used for the Motion Control Operand of motion instruction should be used only once. Reuse of the same Motion Control Operand in other instructions can cause unintended operation of the control variables.

You can read motion status and configuration parameters in your logic by using two methods.

Method	Example
Direct access of the MOTION_GROUP and AXIS structures	<ul style="list-style-type: none"> <li>• Axis faults</li> <li>• Motion status</li> <li>• Servo status</li> </ul>
Use the GSV instruction	<ul style="list-style-type: none"> <li>• Actual position</li> <li>• Command position</li> <li>• Actual velocity</li> </ul>

In your ladder logic program, you can modify motion configuration parameters by using the SSV instruction. For example, you can change position loop gain, velocity loop gain, and current limits within your program.

For more information on the SSV instruction, see the Logix5000 Controllers General Instruction Set Reference Manual, publication [1756-RM003](#).

## Motion Faults

By default, the controller keeps running when there is motion fault. Two types of motion faults exist.

Type	Cause	Description	Example
Instruction errors	Motion instruction	<ul style="list-style-type: none"> <li>• Do not impact controller operation</li> <li>• Should be correct to optimize execution time and be sure of program accuracy</li> </ul>	A Motion Axis Move (MAM) instruction with a parameter out of range

You can configure a fault as either minor or major by using the Axis Wizard Group dialog box.

### *Instruction Errors*

Executing a motion instruction within an application program can generate errors. The MOTION\_INSTRUCTION tag has a field that contains the error code. For more information about error codes for individual instructions, see the Logix5000 Controllers Motion Instruction Set Reference Manual, publication [MOTION-RM002](#).

## Considerations When Running a Motion Application in Windows Operating System

The System Restore feature of the Windows operating system can affect SoftLogix motion applications. The need to use System Restore can occur because other applications running in Windows can impact the time available to run motion. When System Restore is enabled, random motion retries occur, which can result in irregular motion or motion glitches.

The System Restore feature provides a way to restore the system to a previously known state that would otherwise require you to reinstall an application or even the entire operating system. Setup applications that are compatible with the Windows XP operating system, and later, integrate with System Restore to create a restore point before an installation begins. By default, the feature creates a restore point every 24 hours while the system is up. It does this by creating a restore point directory, then snapshotting a set of critical system files, including parts of the registry. System Restore tracks changes to files and directories, and saves copies of files that are being changed or deleted in a restore point change log. Restore point data is maintained on a per-volume basis.

Complete these steps to disable System Restore.

1. From the Start menu, right-click My Computer and choose Properties.

The System Properties dialog box appears.

2. Click the System Restore tab.
3. Clear the System Restore checkbox.
4. Click OK for the change to take effect.



## Windows Considerations

Topic	Page
Observe Windows Objects	241
Additional Considerations	242
Run a SoftLogix Controller on the Windows Operating System	243
HMI Considerations	247
Personal Computer Hardware Considerations	248

This appendix describes considerations when using the Microsoft Windows operating system.

### Observe Windows Objects

There are three objects that execute within the Windows operating system that get CPU resources based on Window's multitasking and multithreading algorithms.

Windows Object	Description
Interrupt service routine (ISR)	<p>An interrupt service routine is a software routine that is primarily executed in response to hardware and software interrupts.</p> <p>ISR always executes immediately and run in the kernel-mode layer of Windows. Each ISR executes at one of 32 levels. The hardware interrupts that occur in a computer get mapped to 16 of the 32 possible levels. The important point about ISRs is that they are written by the vendors of hardware and software products and not Microsoft. Microsoft can recommend how to write ISRs, but there is no guarantee about the how well other vendors write them. For example, once an ISR starts to execute, it can raise its level to a higher priority so that the Windows scheduler won't swap it out, or it can even make a function call to mask all other interrupts until it is finished. Due to the variations in code writing, ISRs can cause swings in system responsiveness and determinism in a soft controller.</p>
Deferred procedure call (DPC)	<p>A deferred procedure call is a software routine that is queued by an ISR to perform less time-critical processing.</p> <p>DPCs also execute in the kernel-mode layer of Windows, and therefore can prevent user mode applications from running. DPCs do not have priority levels, but execute in a FIFO (first-in-first-out) order as queued by their associated ISRs. Poorly written DPCs can unnecessarily keep the SoftLogix controller from running. Disk drivers, network drivers, and video drivers can be major sources of long DPCs, causing variation in SoftLogix performance. Do not use CD writing (recording) devices and fancy screen savers on the SoftLogix controller because they have shown significant jumps in CPU utilization.</p>
Dispatched threads of execution	<p>Threads are the primary execution pieces of software that Windows switches between. Some are associated with larger application programs and background processes, while others are created by the kernel and device drivers.</p> <p>Threads are individual code segments spawned from processes that can be in one of four priority levels; low, medium, high and real-time. Threads that are spawned from a real-time process, like the SoftLogix controller, execute to the point of blocking, yielding, or completing. The dwell component of the SoftLogix controller allows the continuous task of the controller to give time to other lower priority threads that need to execute.</p>

This diagram shows the relationship between these objects and shows how one object has to stop running if another with higher priority wants to execute. The SoftLogix controller executes as a real-time priority process, and thus waits for all ISRs and DPCs to complete before executing.

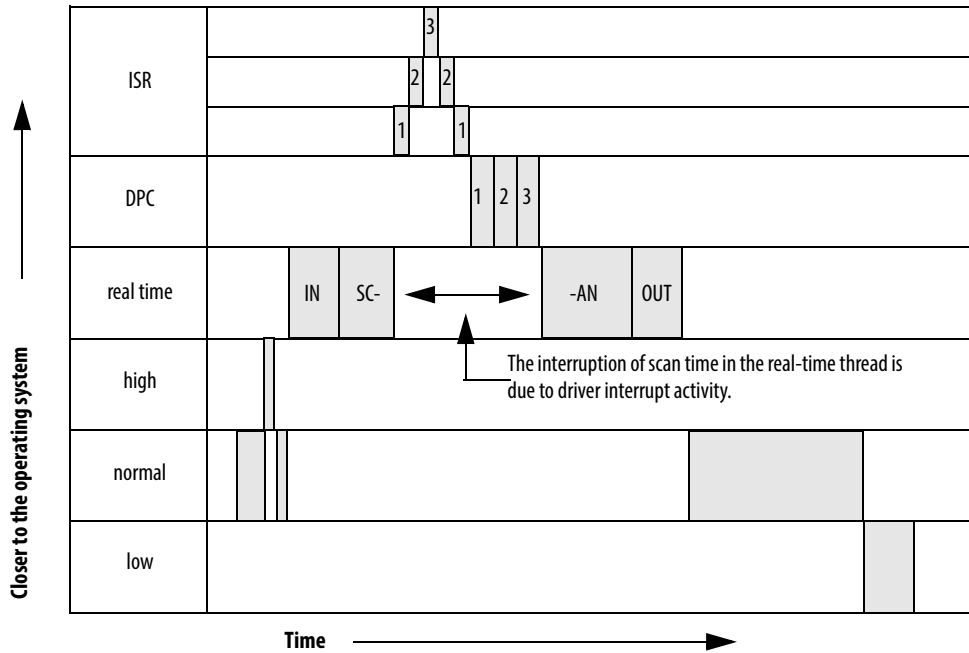

### Additional Considerations

The table describes other considerations for the Windows operating system.

**Table 11 - Windows Operating System Considerations**

Consideration	Description
Multiple CPUs in one computer	Multiple CPUs in the personal computer can greatly improve performance. The Windows scheduler algorithm automatically uses both CPUs to execute whatever needs to be executed. Any code that needs to execute will move to whichever CPU is available, unless the current process specifically requests a certain CPU. The CPU Affinity parameter of the SoftLogix controller has you specify which CPU to execute on, allowing you to customize your system for more determinism.
Blue screen events	Blue screen events are the result of the Pentium processor generating self-diagnostic events that fall in the category of fault or abort. Usually there is code to recover from fault interrupts, such as Page Faults, and these do not cause Windows to stop. But there are occasions in the case of hardware failures that generate a NMI (non-maskable interrupt) or a parity error that are considered faults that cannot be ignored and therefore Windows does the proper thing and immediately stops. This is similar to a PLC-5 processor 'red lighting' when it detects an internal memory or hardware error. Blue screens that occur during system integration of new third-party hardware indicate a poorly written driver that is corrupting Windows kernel memory.  After a blue screen event, the I/O modules controlled by a SoftLogix controller go to their fail safe modes of operation (as specified when the I/O was configured).
Microsoft service pack	Microsoft service pack is the name Microsoft gives to an operating system upgrade. It is always recommended to apply the latest service pack after installing third-party software, especially networking drivers and the addition of network protocols. Whenever you receive errors that seem low-level or don't make sense, reapply the latest Microsoft service pack and restart.
Bus mastering	The hard disk drive must support bus mastering. You might also need bus-mastering drivers for the personal computer chip set. For example, Intel motherboards call this software 'Application Accelerator'.  If you have to restore the operating system to the hard disk drive, the bus mastering software that might have been pre-loaded at the factory, might not get restored during the recovery process and you might have to manually install the software yourself.

**Table 11 - Windows Operating System Considerations**

Consideration	Description
Third party peripheral devices	Third-party peripheral devices, such as network cards and IDE devices should be installed directly in the computer's primary PCI bus. IDE devices should use PCI bus mastering. Bus mastering is the capability of writing directly to the computer's memory without having to use the Pentium chip to move the data. You can use Microsoft's DMACHECK.EXE utility to see whether a third-party card truly uses PCI bus mastering. You might also need to turn bus mastering on within the BIOS setup of your computer. See the documentation for your computer for more information about bus mastering.
TestTime utility	The SoftLogix controller ships with a TestTime utility that you can use to determine the responsiveness of your system to CPU interrupts. The utility measures how long it takes to respond to a software interrupt that is generated every 2 ms. It measures the average, max, number of occurrences and standard deviation of how quickly your personal computer responds. If you find significant delays, focus on any peripheral devices on the computer and their associated drivers. The best way to use the utility is to run it on a new system with no software or third-party hardware installed to get a baseline measurement. Then rerun the TestTime utility each time you install a piece of hardware or a software package to determine if there is an anomaly.
Screen savers	Disable screen savers on your computer. OpenGL screen savers have been known to generate excessive loading on a personal computer. This can cause fluctuations in SoftLogix control because video-driver operations interrupt the SoftLogix real-time execution priority under Windows. OpenGL is a standard for generating 2-dimensional and 3-dimensional graphics in current screen savers and animated games.

## Run a SoftLogix Controller on the Windows Operating System

The SoftLogix controller executes as a service (background program) that starts when the Windows operating system starts and then runs at real-time priority within the Windows operating system. Most other applications, such as word processors and spreadsheets, run at normal priority. Because SoftLogix runs at a real-time level, it is guaranteed to get as many CPU cycles as it needs before allowing the CPU to execute other application programs. Only DPCs and ISRs run before a SoftLogix controller.

### Dwell Time Setting

Every SoftLogix controller has a main task that can be configured to run continuously or periodically. If set for continuous, the main task would use all of the Windows CPU cycles, if it were able, running as a real-time priority process. But the dwell time configuration of the SoftLogix controller is a value in milliseconds, which is directly added to the end of every scan of a continuous program task. The dwell time is a period of time that counts off in real-time after the SoftLogix controller's continuous task. This time is like a sleep time for the SoftLogix controller so that the Windows operating system can execute lower priority threads.

If a SoftLogix controller's periodic task is set to run, it runs during the dwell time, but the time spent executing the periodic task is not added to the dwell time. The dwell time counts in the background in real-time and the end of the dwell marks the continuous task as ready to run. The continuous task will run as long as no other periodic tasks are already executing or are ready to execute.

A dwell time of 0 ms does leave some dynamic amount of time of dwell that is less than 1 ms to prevent you from using all CPU cycles, and thus locking up your computer. When the continuous task enters the dwell time, it makes a function call to the Windows operating system to 'SwitchToThread,' which is a function that lets the next thread that needs to run go ahead and execute.

If multiple SoftLogix controllers in the same virtual chassis are set for a dwell time of 0 ms, the controllers will starve other applications that are running at normal priority. The effect is sluggish mouse control and slow response time by other Windows applications. And if you run this configuration on a slower computer, you may even lock yourself out of being able to do anything in the Windows operating system.

---

**IMPORTANT** It is possible to lock yourself out of your computer if you have multiple controllers installed in the virtual chassis and the following:

- Each controller is set for a dwell time of 0.
- Periodic tasks are set for very low settings (short time periods).

In this state, the keyboard and mouse are not recognized by the Windows operating system because the Windows operating system is spending all of its time executing the real-time tasks of the SoftLogix controllers. If the controllers are set to start in 'last state,' you will never be able to move the mouse to put them in Program mode to free up CPU resources.

It is recommended that during development, set the controller to start in the Remote Program mode. This way, if you ever have controllers in Run mode and the personal computer locks up, you can cycle power and have the controllers come up in Program mode, giving you enough CPU time to make changes to your application to correct the anomaly. Then after development is complete, you can change the Startup mode to start in 'last state.'

---

There is no window in RSLogix 5000 software that shows overall scan time including the dwell time component. The scan times reported in each task are values that indicate the time to scan a particular program and do not include dwell time. Use the Task Manager's Performance Monitor to gauge the effect of dwell time settings.

## Periodic Tasks

Periodic tasks always attempt to execute according to their setting, and they always interrupt the continuous task. If the controller is running its dwell time, a periodic task still interrupts the dwell time to run. If two periodic tasks attempt to run at the same time, the task that has the higher priority executes first. Be careful not to execute too many periodic tasks with short intervals as you can start to use all the bandwidth of the computer without leaving CPU cycles to operate the mouse and keyboard.

A periodic task pauses if an ISR or DPC routine needs to be executed by the Windows operating system, and then the periodic task continues when the interrupt is complete. The periodic task executes again in real time at the next preset interval. The time spent in the ISR or DPC does not get added to the time counted between periodic tasks.

A periodic task detects an overlap and sets the Overlap fault bit in the controller if a periodic task fails to run at all during its assigned time slot or if a periodic task starts later than scheduled and cannot complete before the start of the next period. This diagram shows periodic task intervals, when a task actually starts, and what is considered an overlap condition.

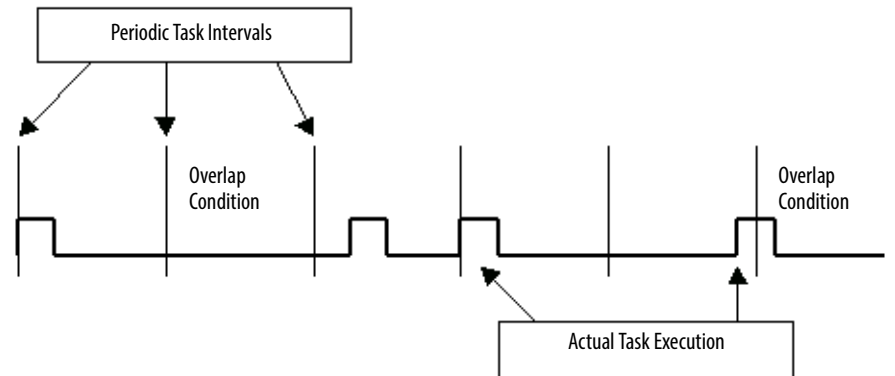

If two controllers in the same virtual chassis each have high priority periodic tasks and the tasks become active at the same time, the Windows operating system tries to switch between the tasks at whatever quantum is set within the Windows operating system. The quantum varies based on the performance boost setting for the process. With no performance boost, the quantum is 20 ms for the Windows workstation. Typically a SoftLogix controller finishes the entire scan of a periodic task before using a whole quantum.

To use the whole quantum, a thread has to be ready to execute the whole time. If a thread stops and makes any type of I/O call, (such as disk drive, DRAM memory, and so forth), the thread gets switched by the Windows operating system and the CPU executes the next thread that is ready to run. This applies to the SoftLogix controller because the controller references different tags in a program scan, which are DRAM I/O operations. Therefore, the Windows operating system switches back and forth many times between two periodic tasks that are executing at the same time and at the same priority level, with the switching happening in the microsecond range.

The following diagram shows the timing of task execution between two SoftLogix controllers in the same virtual chassis. Each controller has periodic tasks and a continuous task. The example periodic tasks are short and take only 0.25 ms to execute. The example continuous tasks take 0.5 ms to execute. Anytime two periodic tasks need to execute at the same time and they each have the same priority, they share CPU cycles as the Windows operating system constantly switches between.

The beginning of the diagram shows what happens when the controller goes from Program mode to Run mode, which involves a prescan of all tasks. Then Run mode begins. The real time starts counting as shown at the bottom of the diagram.

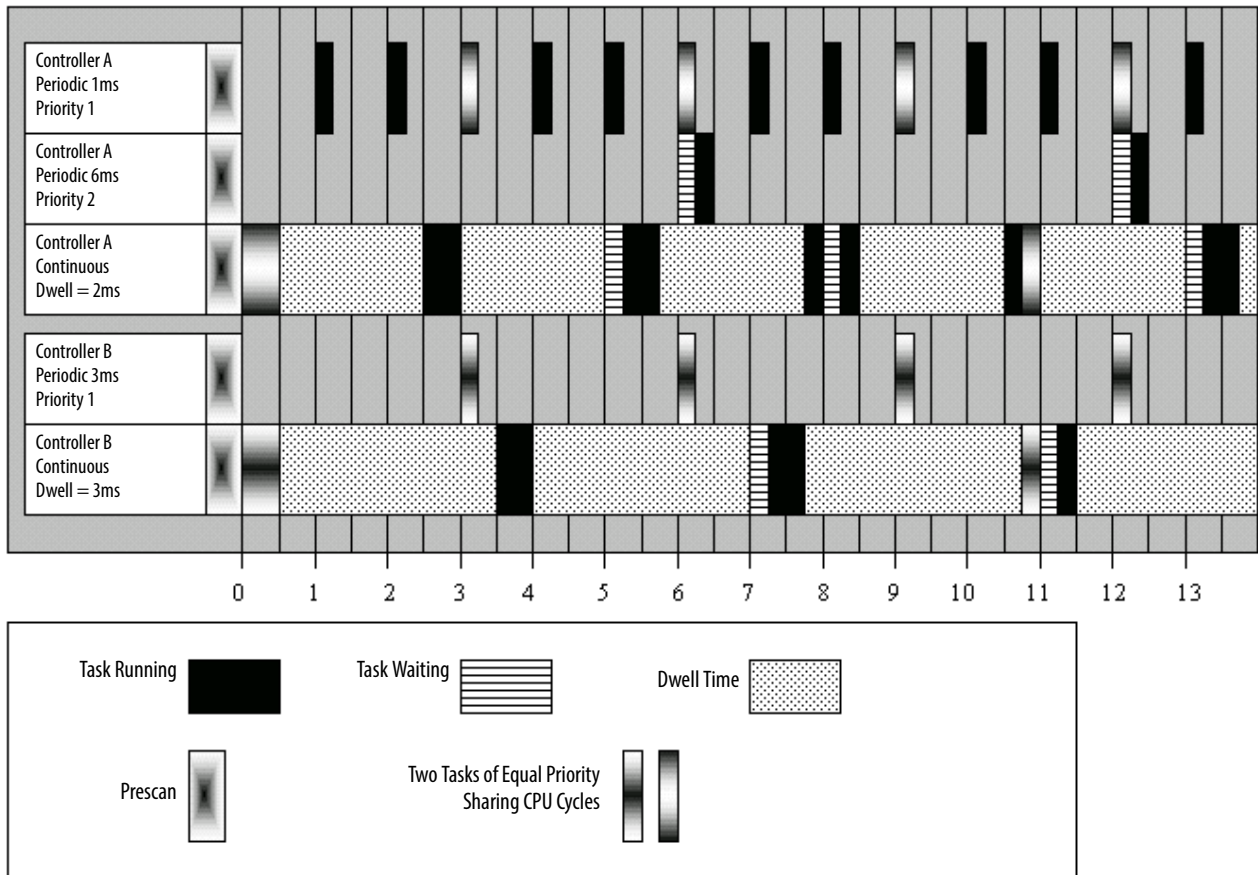

## System Overhead Timeslice

All Logix-based controllers have a configuration setting for the system overhead timeslice. This function lets the controller take care of communication requests that occur from other controllers or from queued requests from within the controller's application program. The timeslice switches the priority level of the continuous task with that of the background communication task, which is always running at a lower level than the continuous task.

The timeslice setting is a percent value that is applied to a 100 ms background timing window. With a setting of 10% (the default), for every 100 ms of real time, there is 10 ms of time when the communication task priority is higher than the continuous task. If there is communication activity to perform, the controller does it and when completed, the controller lets the continuous task run again during that 10 ms window. For the next 90 ms, the continuous task is at its normal priority and the communication task is lower. During dwell time, if there are communication tasks ready to run, they will run during the dwell even though the communication task is not switched to a higher priority. And any periodic task that needs to run overrides both the continuous task and the communication task.

## Multiple SoftLogix Controllers in the Virtual Chassis

Multiple controllers in the virtual chassis, executing on a computer with only one CPU, is less efficient than one controller. With multiple controllers, the Windows operating system has to take time to swap threads in a round-robin fashion, assuming all the controllers have a continuous task and a very small dwell. If your computer has multiple CPUs, then assign multiple controllers across the multiple CPUs.

## HMI Considerations

Considerations when running an HMI and a SoftLogix controller on the same computer include the following.

Consideration	Description
HMI initialization	Make sure RSLinx software and the SoftLogix controller completely initialize on the computer before the HMI begins to initialize. Otherwise, you may experience memory assignment anomalies.
Network connection	If the computer loses the network connection (there is no connection to a local switch), on Powerup, Windows 2000/XP do not initialize Ethernet ports or the TCP/IP stack. This results in the HMI not being able to communicate with the SoftLogix controller because the HMI uses the TCP/IP stack. To avoid this, use a loopback adapter for communication.

## Personal Computer Hardware Considerations

The personal computer hardware you chose for the SoftLogix controller will have a dramatic impact on the performance of the SoftLogix control system.

Most SoftLogix applications run additional software on the same personal computer as the controller. Make sure the computer meets these requirements:

- IBM-compatible Pentium 4 1.6 GHz
- 256 KB of RAM
- 50 MB free hard disk space

Demanding applications including sequential, motion, HMI, and other local applications running on the personal computer may require a dual CPU to achieve performance requirements.

Other considerations include the following.

Consideration	Description
Hard disk drives	The hard disk drive is capable of bus mastering to reduce loading on the Pentium processor. Bus mastering allows the hard disk drive to initiate data transfers without using Pentium CPU cycles. To accomplish this the personal computer must have a motherboard that supports this technology as well as a BIOS that supports it. Then the drive itself is capable of bus mastering. Most personal computer vendors will fully integrate for you this IDE bus mastering capability.
CD-ROM drives	Verify that the hard disk drive for your personal computer is on a designated IDE channel and that the CD-ROM drive is on another (secondary). Some personal computer vendors attempt to put the CD-ROM as slave off of the primary IDE channel and this causes performance difficulties for the hard disk drive.
Redundant array of disks (RAID)	This technology uses multiple hard disk drives in a personal computer, so that any one hard disk drive can fail without causing Windows to crash. There are 5 different versions of RAID, each with its own method of error correction and recovery. The SoftLogix controller supports the RAID environment, which is recommended for critical applications that can't afford a crash.  Sensitivity to hard disk drive crashes is common among personal computer users, but over the last 5 years, the reliability of hard disk drives has greatly increased. RAID technology is expensive and can be hard to implement and support. A more inexpensive option is to have another hard disk drive with a copy of the original hard disk drive image available. You can even mount the duplicate in the same personal computer without power or IDE connections, so that it is ready to connect if the original hard disk drive ever fails.
Uninterruptable power supplies (UPS)	Uninterruptable power is an excellent accessory for a SoftLogix system as it prevents disruptions to the SoftLogix controller due to brown outs and power outages, which are the most common interferences to personal computers. There are many UPS systems available, including some with digital outputs that can be interfaced back into the SoftLogix controller by using discrete inputs so that the controller can detect a power outage and prepare for an orderly shutdown after a designated amount of time.

---

**IMPORTANT** Make sure the SoftLogix computer does an orderly shutdown of the Windows operating system on a power failure or you may end up with operating system anomalies.

---



## System Performance Tuning Guidelines

Topic	Page
Pre-qualify Your Personal Computer for Soft Control	249
System Performance	252
System Startup	253
Monitor Personal Computer Performance	253

The amount of personal computer processing power required for your application depends on your control application configuration. For example, the number of tasks, periodic rate settings, number of data tags, and whether other windows applications are running on your computer. This appendix describes the effect of these items and provides some guidelines on how to maximize system performance.

The CPU speed of the personal computer and whether the system is a single or dual Pentium are also important. The developer of the soft control system must partition and scale the application correctly for the capabilities of the personal computer.

### Pre-qualify Your Personal Computer for Soft Control

After installing the SoftLogix 5800 controller on your personal computer, verify that the system performance is appropriate for soft control. This is not usually an anomaly on computers pre-configured and supplied by major vendors.

Run the TestTime utility that is installed with the SoftLogix 5800 controller. Let this application run for a period of time while you perform tasks that you normally run on the computer. When minimized, the utility monitors your system in the background.

When you open the utility, this information appears.

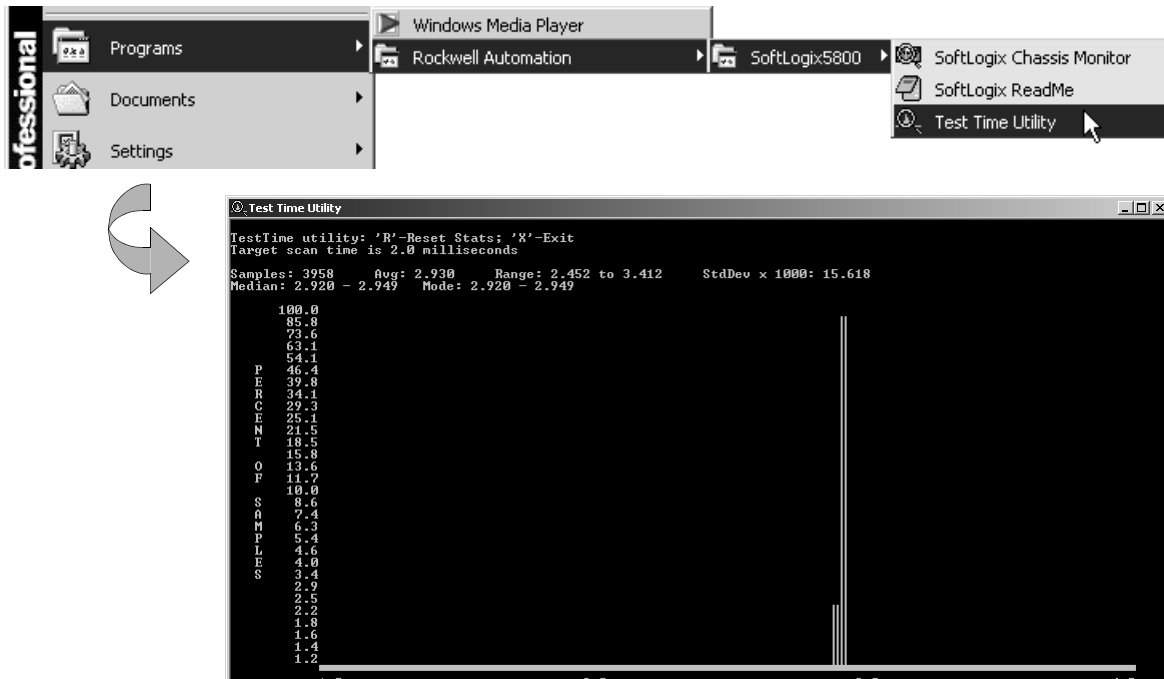

The Test Time utility monitors your system’s responsiveness to a repetitive 2 ms timer. It displays both a textual and a graphical display of the timing response of your computer. If your system is set up and operating properly the maximum value in the range should be no greater than 3 or 4 ms. If the value is significantly higher, your system is not appropriate for running SoftLogix Chassis Monitor and performing machine control. Some reasons why your system might not behave as expected include the following:

- The system does not have bus mastering enabled. For information on bus mastering, see the personal computer hardware considerations in [Appendix D](#).
- The system has an ‘ill-behaved’ device driver that violates the Microsoft Windows Hardware Quality Lab (WHQL) guidelines. Verify that you have the correct vendor-specific device driver loaded for your video, Ethernet, sound, SCSI, IDE, and so forth. devices. These drivers should be ‘signed’ by Microsoft, or if provided by another vendor, the driver should be certified by the Microsoft Windows Hardware Quality lab. Most vendors will indicate driver that have been WHQL certified on their driver download web page.
- Your system has an ISA Ethernet or other expansion card that is not bus-mastering capable. You can verify this by removing the ISA card and running Test Time again.
- There is another real-time priority application running on the personal computer. Typically, the only commercially available software that can cause this type of anomaly is CD writer software.

- Check that your personal computer BIOS is compatible with the operating system. Windows 2000 and Windows XP power management features and other aspects of the operating system require support in the personal computer vendor's supplied BIOS. Check your personal computer vendor's website for updated BIOS versions and for details on which operating systems are supported.
- Your system is running Windows 2000 or Windows XP operating system and is subject to the 'System Performance Counter Unexpectedly Leaps forward problem' as described in the Microsoft Knowledgebase. Many systems will not demonstrate this anomaly unless actually running the SoftLogix 5800 controller. This anomaly causes unexpected watchdog timeouts and I/O connection timeouts. There is no feasible workaround on these systems. The alternative is to upgrade your personal computer such that it does not contain the affected South Bridge chipset.
- You are trying to run the SoftLogix 5800 controller on a platform that does not meet the minimum system requirements of a Pentium 4 1.6 GHz or greater.
- There is not enough RAM or disk space. Sufficient RAM keeps memory swapping by the operating system to a minimum. Ample disk space and a defragmented drive prevent excessive hard disk accesses.

## System Performance

There are a number of configurable parameters in the SoftLogix 5800 controller that affect the overall system performance of your personal computer. These are the parameters.

**Table 12 - Parameters for Improved Performance**

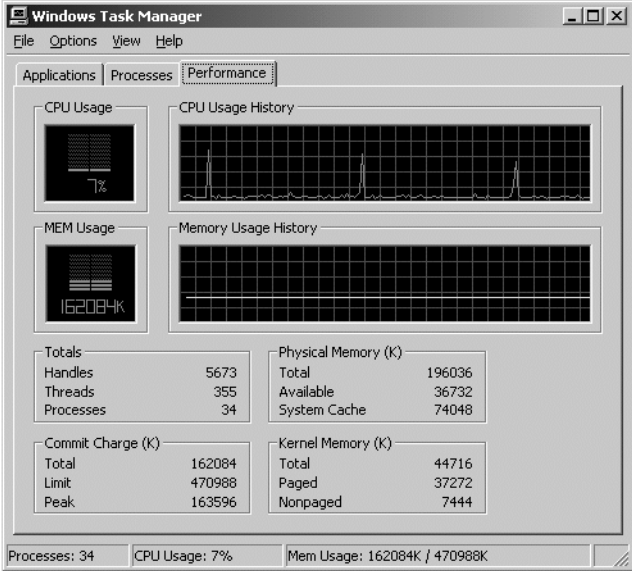
SoftLogix Parameter	Description
Continuous task dwell time	By default this value is 10 ms. Your application should be structured such that the continuous task contains programs that are not time critical so that you can adjust the dwell time to a value as large as possible. For time critical tasks use Periodic type tasks and be prudent in the number of periodic tasks and the configured period.
Periodic save interval	<p>This parameter should also be set as large as possible to a value that is appropriate for your application. Every time the periodic save runs, SoftLogix high priority tasks consume CPU time to save tag values and the user program to the hard disk.</p> <p>This setting does not affect the storing of online edits to the hard disk. Edits saved at:</p> <ul style="list-style-type: none"> <li>• Next periodic save interval</li> <li>• User-initiated save</li> <li>• Controller shutdown</li> </ul> <p>You can also observe the execution of the periodic save in the Windows Task Manager. It is possible that if you set the time interval short and have a large number of tags that the periodic save runs continuously. This in itself is not an anomaly, however as a goal, keep the overall CPU use below 80% on a continuous basis. This leaves headroom for other Windows applications to run properly. If your system cannot be tuned to achieve this, then it is recommended you use a dual Pentium personal computer or upgrading to a faster Pentium processor.</p> <div style="display: flex; align-items: center;">  <div style="margin-left: 10px;"> <p>The spikes show when the periodic save is running.</p> </div> </div>
CPU affinity	<p>Use the CPU affinity setting on a dual Pentium processor personal computer to balance the overall system performance. You can:</p> <ul style="list-style-type: none"> <li>• Run control on one CPU and leave the second CPU for other Windows applications.</li> <li>• Install two SoftLogix controllers in the virtual chassis and set the affinity of each to a different CPU.</li> </ul> <p>For the best overall performance, especially when using integrated motion, use one SoftLogix controller in the virtual chassis on a single CPU system.</p>
EtherNet/IP connections	The total number of connections from an EtherNet/IP port in a SoftLogix controller depends on the performance of the computer running the controller. As you increase the number of connections, the performance of the computer decreases.

## System Startup

There are much greater CPU demands on the personal computer during system starts up. This is due to the fact that the SoftLogix controller restores its application program so that it can restart in the same state as it was shutdown. This restore is done at a high priority level so that the time from 'power button press' to running the control application is as short as possible. While the restore is occurring, other Windows applications are also putting demands on the personal computer system during their Start-up phase.

If the system CPU load is too great during startup, Windows displays the Server Busy dialog box. If this condition occurs for other applications, such as SQL server, Microsoft Internet Information Server, Virus scanners, or disk defraggers, you should delay starting other Rockwell applications, such as RSSQL and RSView, until after the controller has completed its restore process and begins executing its application.

A SoftLogix controller with a typical application on a contemporary personal computer takes about one to two minutes to complete Powerup and restore of the application. See A2048/A9662 TechNote on how to delay the startup of other applications on the personal computer.

## Monitor Personal Computer Performance

Standard installations of the Windows XP operating system include a personal computer performance utility that is useful for monitoring send and receive parameters. This utility is available as part of Administrative Tools.

You might have to customize the Start menu to display the Administrative Tools option. To do this, follow these steps.

1. Right-click Start and choose Properties.

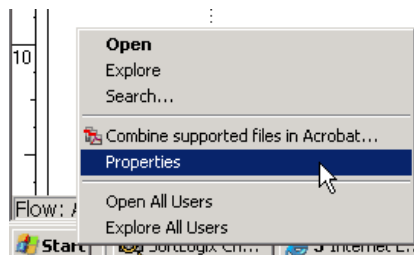

2. From the Properties menu, click Customize to customize the Start menu to display the Administrative Tools Option.

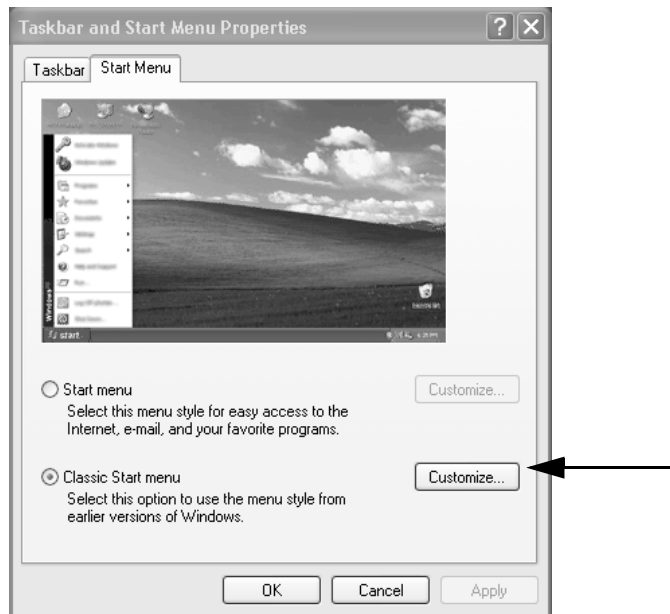

The Customize Classic Start Menu dialog box appears.

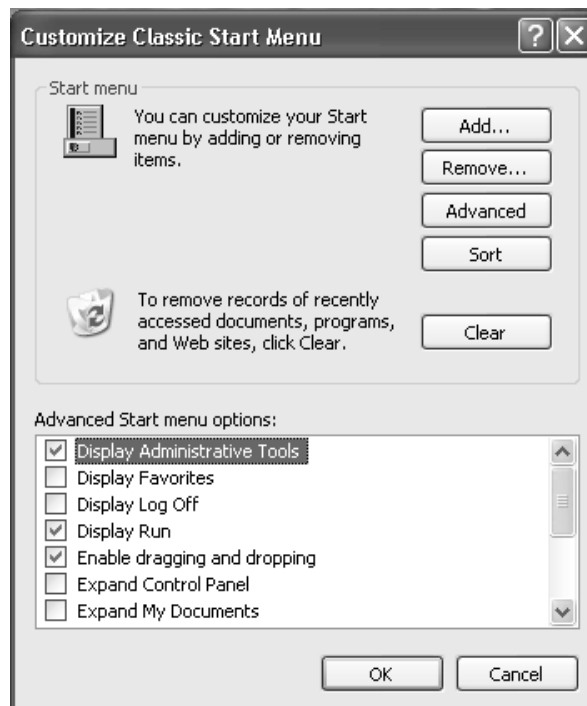

3. Choose the Display Administrative Tools and click OK twice.

- From the Start menu, choose Programs>Administrative Tools>Performance.

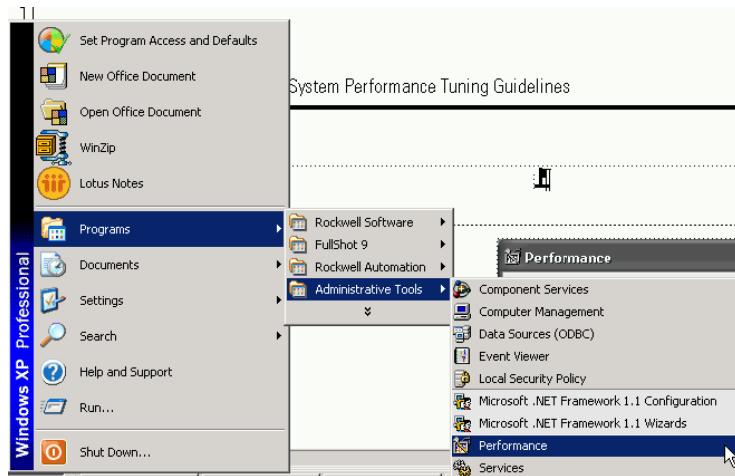

The Performance dialog box appears.

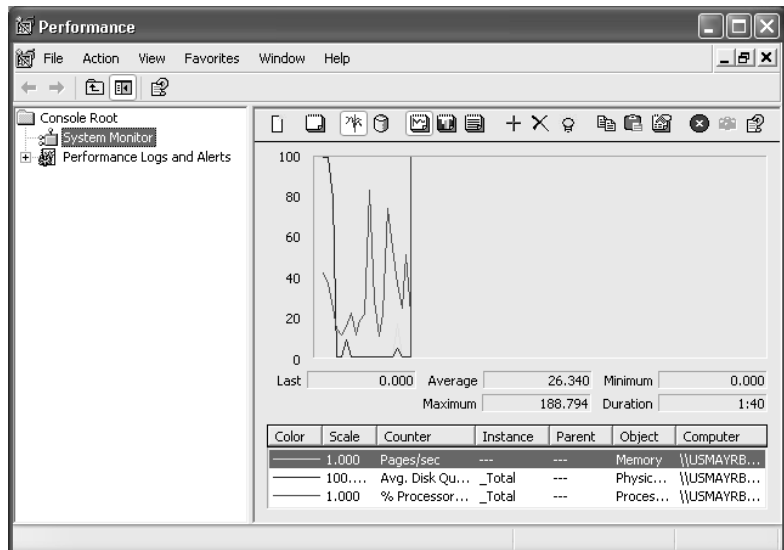

## Notes:



## Status Indicators

Topic	Page
SoftLogix Controller Status Indicators	257
SoftLogix EtherNet/IP Module Status Indicators	259

This appendix describes the status indicators for the SoftLogix 5800 controller and its associated modules.

### SoftLogix Controller Status Indicators

The controller has these status indicators.

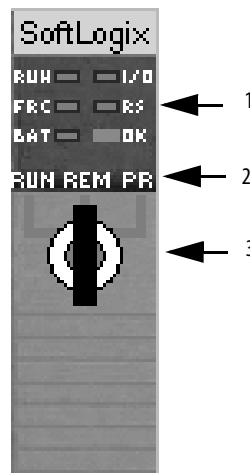

Indicator	Description
1	Module display status
2	Mode display
3	Key switch

## Controller Status Indicator and Display

Indicator	Status	Description
RUN	Off	The controller is in Program or Test mode.
	Solid green	The controller is in Run mode.
I/O	Off	Either: <ul style="list-style-type: none"> <li>There are <i>no</i> devices in the I/O configuration of the controller.</li> <li>The controller does <i>not</i> contain a project (controller memory is empty).</li> </ul>
	Solid green	The controller is communicating with all the devices in its I/O configuration.
	Flashing green	One or more devices in the I/O configuration of the controller are <i>not</i> responding.
	Flashing red	A virtual chassis error was detected. Contact your Rockwell Automation representative or local distributor.
FRC	Off	No tags contain I/O force values. I/O forces are inactive (disabled).
	Flashing green	At least one tag contains an I/O force value. I/O force values are inactive (disabled).
	Solid green	I/O forces are active (enabled). I/O force values may or may not exist.
RS232 <sup>(1)</sup>	Off	No COM port was selected.
	Solid green	The selected COM port was successfully assigned to channel 0 of the controller.
	Solid red	There is a COM port conflict or you selected an invalid COM port number.
BAT <sup>(1)</sup>	Off	Normal operation.
	Flashing amber	The controller is in Power-up mode.
	Solid red	Persistent storage for the controller has failed.
OK	Flashing red	If the controller is a new controller, then the controller requires a firmware update. And the controller is not a new controller, then a major fault occurred. To clear the fault, either: <ul style="list-style-type: none"> <li>Turn the keyswitch from PROG to RUN to PROG</li> <li>Go online with RSLogix 5000 software</li> </ul>
	Solid red	The controller detected a non-recoverable fault, so it cleared the project from memory. To recover, follow these steps. <ol style="list-style-type: none"> <li>Cycle power to the chassis.</li> <li>Download the project.</li> <li>Change to Run mode.</li> </ol> If the OK status indicator remains solid red, contact your Rockwell Automation representative or local distributor.
	Solid green	The controller is OK.

(1) Note that these status indicators function slightly different than the same status indicators on a ControlLogix controller.

## SoftLogix EtherNet/IP Module Status Indicators

This section describes the EtherNet/IP modules' status indicators for the SoftLogix system.

The EtherNet/IP modules have these status indicators.

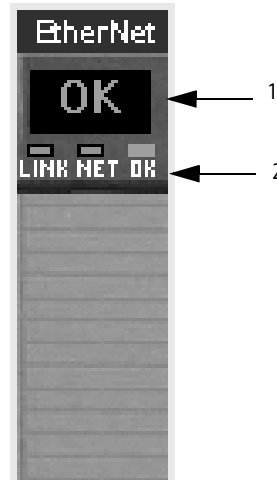

Indicator	Description
1	Module display status
2	Module status indicators

### Link Status (LINK) Indicator

LINK Indicator	Display	Description
Off	No link	<ul style="list-style-type: none"> <li>The module is not connected to a powered Ethernet device.</li> <li>The module cannot communicate on Ethernet. Verify that all Ethernet cables are connected.</li> <li>Verify that the Ethernet switch is powered.</li> </ul>
Flashing green	Data transmission	<ul style="list-style-type: none"> <li>The module is communicating on Ethernet.</li> <li>Normal operation. No action required.</li> </ul>
Solid green	Link OK	<ul style="list-style-type: none"> <li>The module is connected to a powered Ethernet device.</li> <li>The module can communicate on Ethernet.</li> <li>Normal operation. No action required.</li> </ul>

## Network Status (NET) Indicator

NET Indicator	Display	Description
Solid green	CIP connections established	<ul style="list-style-type: none"> <li>The module has an IP address and CIP connections (Class 1 or Class 3) are established.</li> <li>Normal operation. No action required.</li> </ul>
Flashing green	No CIP connections established	<ul style="list-style-type: none"> <li>The module has an IP address, but no CIP connections are established.</li> <li>Normal operation if no connections are configured. No action required.</li> <li>If connections are configured, check connection originator for connection error code.</li> </ul>
Flashing red	Lost network connection	<ul style="list-style-type: none"> <li>The module detected that the network connection has been lost.</li> <li>Verify that all Ethernet cables are connected.</li> <li>Verify that the Ethernet switch is powered.</li> </ul>

## Module Status (OK) Indicator

OK Indicator	Display	Description
Solid green	OK	<ul style="list-style-type: none"> <li>The module is operating correctly.</li> <li>Normal operation. No action required.</li> </ul>
Flashing green	Standby	<ul style="list-style-type: none"> <li>The module is not configured correctly.</li> <li>Verify the module's configuration.</li> </ul>
Solid red	Major fault	<ul style="list-style-type: none"> <li>An unrecoverable fault has occurred.</li> <li>Cycle power to the controller. Correct the fault.</li> </ul>
Flashing red	Minor fault	A recoverable fault has occurred. Correct the fault.

---

## SoftLogix 5800 Revision History

This appendix summarizes the revisions to this manual. Reference this appendix if you need information to determine what changes have been made across multiple revisions. This may be especially useful if you are deciding to upgrade your hardware or software based on information added with previous revisions of this manual.

### SoftLogix 5800 Version 23

---

**Change**

---

General SoftLogix 5800 release to coincide with the Studio 5000 Logix Designer application version 23

---

### SoftLogix 5800 Version 21

---

**Change**

---

The Studio 5000 Logix Designer application has now replaced RSLogix5000 software

---

Studio 5000 has been added

---

### SoftLogix 5800 Version 20

---

**Change**

---

New content redesign places a small Table of Contents before the introductory text in each section to better assist you with locating information.

---

The RSLinx software module can be programmed for another slot in the virtual chassis monitor other than default Slot 0.

---

**Notes:**

## Numerics

### 1784-PCICS

- card
  - chassis monitor 199
  - communication 196
  - configuring 200
  - ControlNet connection 40
  - creating 197
  - SoftLogix controller 196

### 1784-PCIDS

- card 192
  - chassis monitor 165
  - configure 169
  - create 163
  - rack-optimized 188
  - RPI 189
  - slave nodes 191

### 1789-SIM module

- creating 94
- force a bit 102
- using 93

## A

### add

- external routines 106

### alias

- tag
  - create 194

### analog

- module
  - tag 221

### array

- rack-optimized 193

### ASCII

- device
  - controller 90
- protocol 90

## B

### bit

- force 102
- on 102

### bus mastering

## C

### calculating

- cam instruction 37

### card

- 1784-PCIDS 192
- create 197
- Ethernet communication 48

### characteristics

- chassis monitor 25

### chassis monitor

- 1784-PCICS card 199
- 1784-PCIDS card 165
- characteristics 25
- overview 24
- SIM module 94

### COM port

- setting 78

### command

- register bits 190

### communication

- card
  - configure 50, 199
  - PCI slot 196
  - remote devices 204
  - run mode 190
- ControlNet network 195
- DeviceNet network 161
- DeviceNet network driver 166
- driver for ControlNet 198
- Ethernet 54
- serial 75

### configure

- 1784-PCICS card 200
- 1784-PCIDS card 169
- ASCII protocol 90
- communication card 50, 199
- controller 27, 32
- ControlNet system 195
- DeviceNet network 162
- DF1 point-to-point 86
- DF1 slave 88
- external routines 105
- memory size 25
- MSG instruction 69
- remote device 56
- RSLink gateway 47
- serial link 75
- serial port 76
- SIM module 93
- simulated I/O 93
- SoftLogix 25
- user mode 91

### connection

- direct 221
- EtherNet/IP 54
- listen-only 220
- overview 38
- rack-optimized 188, 220
- remote 65
- requirements 40
- SoftLogix
  - controller 223
  - system 23

### consideration

- HMI 247
- personal computer hardware 248
- Windows 241

### continuous task dwell time

- SoftLogix 25

**control**

- I/O modules 222
- motion devices 237
- structure 112, 113, 120

**controller**

- ASCII device 90
- configure 27, 32
- EtherNet/IP network connection 55
- event task 153
- motion faults 239
- online 41
- programmatically saving 158
- project creation 31
- project upload 41
- restart 41
- single-float values
  - SoftLogix 37
- SoftLogix 27
- SoftLogix to ControlNet 223
- status indicators 85, 257
- Windows event 149, 158
  - task 153

**ControlNet network**

- 1784-PCICS card 197
- communication driver 198
- configuring 1784-PCICS card 200
- configuring the system 195
- connection
  - 1784-PCICS card 40
- devices 195
- extended properties 222
- hardware 196
- overview 195
- placing I/O 219
- scheduling 213
- SoftLogix as a gateway 234
- SoftLogix controller and I/O 222
- SoftLogix to other devices 228
- SoftLogix to SoftLogix controller 223

**converting INTs to REALs 37****CPU affinity 28, 252****create**

- 1784-PCICS card 197
- 1784-PCIDS card 163
- 1789-SIM module 94
- alias tag 194
- card 197
- controller project 31
- Ethernet card 48
- HTML resource 123
- module 27
- single-threaded external routine 117

**D****data**

- Ethernet I/O 58
- map I/O 100
- update cycle 189

**debugging external routines 136****determine**

- data update 189

**developing**

- external routine 115
- motion logic 238
- program 34

**device**

- ControlNet network 195

**DeviceNet network**

- access I/O modules 188
- command register bits 190
- communication driver 166
- configure 1784-PCIDS card 169
- create 1784-PCIDS card 163
- hardware 162
- overview 161
- scanlist 172
- SoftLogix 161
- SoftLogix I/O 193
- status data 192
- status register bits 191
- system configuration 162
- test 181

**DF1**

- Master protocol 84
- point-to-point configuration 86
- point-to-point protocol 84
- protocol
  - master and slave methods 87
  - slave 88
- radio modem 84
- slave protocol 84

**DINT**

- rack-optimized 189
- rack-optimized connection 220

**direct connection 221****disable**

- system restore 240
- UDP 45

**distributed I/O**

- Ethernet 56
- SoftLogix 73

**download**

- external routine 117, 130
- physical address information 41

**DPC**

- routine 244

**drivers 242****dual CPU 26****dwel time 252**

- Windows 243

**E****enable**

- UDP 46

**error**

- fault 239

**Ethernet**

- communication 54



- card 48
- configuring the controller 43
- controller connection 54
- creating Ethernet card 48
- disabling UDP 44
- distributed I/O 56
- example sending message to PLC-5 71
- example sending messages 68
- I/O data 58
- message 68
- module status indicators 259
- multiple EtherNet/IP modules 54
- port 22
- remote workstation to SoftLogix controller 65
- RSLinux UDP messages 44
- EtherNet/IP network**
  - access remote device 58
  - controller connection 55
  - module functionality 56
  - multiple modules 54
  - remote device 56
  - statistics 63
- event** 35
  - task
    - controller 153
    - trigger 156
- example** 150
  - dumpbin.exe 145
  - external routine
    - array 139
    - integer 140
    - string 142
    - structure 141
  - InlineExample.cpp 121, 145
  - InlineExample.h 122, 145
  - messages over Ethernet 68
  - messages over Ethernet to PLC-5 71
  - outbound event 150
  - programmatic save 158
  - RA\_ExternalRoutine.h 119
  - remote workstation to SoftLogix over Ethernet network 65
  - remote workstation to SoftLogix via serial device 86
  - simulating I/O 103
  - SoftLogix controller
    - and I/O over ControlNet network 222
    - to a bar code reader 90
  - SoftLogix controller as a gateway 234
  - SoftLogix to other devices via ControlNet network 228
  - Sounds.cpp 131
  - Windows event 156
  - workstation to SoftLogix via serial device 85
- exporting functions** 145
- extended properties**
  - ControlNet 222
- external routines**
  - add 106
  - calling 112
  - configure 105
  - controller functions 116
  - debugging 136
  - developing 115
  - download 117, 130
  - editing the DLL 118
  - exporting functions 145
  - HTML resource 123
  - jump 112
  - JXR instruction 112
  - multithreaded 130
  - packing in structures 143
  - project 111
  - single-threaded 117
  - thread priorities 135
  - type checking 114, 138
  - updating 130
  - using Visual Studio 117
  - version information 128
  - XML descriptions 126
- F**
- fault**
  - error 239
- force a bit**
  - 1789-SIM module 102
- function block**
  - software 22
- functionality**
  - EtherNet/IP module 56
- G**
- Generic module**
  - SIM module 97
- H**
- hardware**
  - ControlNet network 196
  - DeviceNet network 162
- HMI**
  - application
    - periodic save interval 26
  - consideration 247
  - responsiveness 26
- HTML resource** 123
- I**
- I/O**
  - module
    - ControlNet network 219
  - module access via DeviceNet network 188
  - simulating 93
- input**
  - instance status 98
  - size

- status 98
- toggle 101
- instruction**
  - error
    - motion 239
  - execution 37
  - MAM 239
  - motion 238
  - PLC-5 message 71

**INT to REAL conversion** 37

**IOLinx**

- software 22, 191

**IP address** 54

**ISR**

- routine 244

## J

**jump**

- external routines 112

**JXR instruction**

- control structure 112, 113, 120
- operands 112

## L

**ladder logic**

- software 22

**LINK**

- status indicators 259

**listen-only**

- connection 220

**logic**

- motion 238

## M

**major**

- fault 99
- revision number
  - 1784 PCIDS card 170

**MAM**

- instruction 239

**map**

- I/O data 100
- simulated I/O 100

**MAPC instruction**

- calculating
  - cam 37

**master** 87

- slave communication 87

**math operations** 37

**media configuration** 216

**memory**

- size 25, 28

**message**

- Ethernet 68
- PLC-5 processor 71

**mode**

- run 190, 246
- standard polling 89
- startup 25, 28

**modem**

- DF1
  - radio 84

**module**

- create 27
- reset 180

**monitoring simulated I/O** 101

**motion**

- control operand
  - motion 238
- developing logic 238
- faults
  - controller 239
- instruction 238
  - error 239
- logic 238
- motion control operand 238
- overview 237

**MSG instruction**

- configure 69

**multiple**

- controllers
  - SoftLogix 247
- CPUs 242
- modules
  - EtherNet/IP 54

**multithreaded external routines** 130

## N

**NET**

- status
  - indicators 260

**Net** 22

**network**

- ControlNet 22
- DeviceNet 22
- parameters 216

**no handshake** 83

## O

**object**

- Windows 241

**OK**

- status indicators 260

**on**

- bit 102

**online**

- controller 41

**outbound event** 150

- Windows 149

**output**

- instance
  - status 98

**overview**

- connection 38
- SoftLogix 21

**P**

**PCI slot**  
communication card 196

**PCIDS**  
card  
major revision number 170

**performance**  
personal computer 253  
system 252

**periodic** 28  
save 252  
save interval  
high user mode 26  
HMI application 26  
normal user mode 26  
task Windows 244

**personal computer**  
hardware consideration 248  
performance 253

**physical address information**  
download 41  
upload 41

**PLC-5**  
message instruction 71  
processor message 71

**port**  
Ethernet 22  
serial 28

**pre-qualify**  
soft control 249

**priority** 35  
level task 34

**program**  
defining 36  
developing 34  
development 34

**programmatically saving**  
controller 158

**project**  
developing 34  
external routines 111  
program 36  
routine 37  
serial port 81  
SIM module 97  
task 34

**R**

**rack-optimized**  
1784-PCIDS card 188  
array 193  
connection 188, 220  
DINT element 189

**reloading operating system** 242

**remote**  
\_flex 220  
communication device card 204  
connection 65  
controller 60  
device  
accessing over EtherNet/IP 58  
configuring EtherNet/IP 56  
tag 220

**requirements**  
connection 40

**reset**  
module 180

**restart**  
controller 41

**routine** 37  
DPC 244  
ISR 244

**RPI**  
1784-PCIDS card 189  
SIM module 99

**RSLinx**  
configure gateway 47  
software 28, 166, 195, 198  
software 203  
UDP Ethernet messages 44

**RSLogix 5000**  
software 196  
type checking 114

**RSNetWorx**  
for ControlNet  
software 196  
for DeviceNet  
software 173  
software 22

**run**  
mode 190, 246  
communication card 190

**S**

**scanlist**  
DeviceNet network 172

**schedule**  
ControlNet network 213

**selecting**  
system overhead percentage 42

**serial**  
ASCII  
protocol 90  
configuring the port 82  
example SoftLogix controller  
to a bar code reader 90  
link configuration 75  
overview 75  
port 28  
port configuration 76  
port project 81  
remote workstation connected to SoftLogix  
controller 86  
slave 88  
workstation connected to SoftLogix controller  
85

**setting**  
COM port 78

**SIM module**

- chassis monitor 94
- configure 93
- Generic module 97
- project 97
- RPI 99
- SoftLogix
  - controller 93
- tag 103

**simulated I/O**

- configure 93
- creating 1789-SIM module 94
- example 103
- map
  - data 100
- outputs in last state 101
- toggling inputs and outputs 101

**size**

- memory 28

**slave**

- 87
- master communication 87
- nodes
  - 1784-PCIDS card 191

**soft control**

- pre-qualify 249

**SoftLogix**

- chassis monitor 24
- configuration 25
- continuous task dwell time 25
- controller 27
  - 1784-PCICS card 196
  - connection 223
  - SIM module 93
  - single-float values 37
  - Windows 243
- controller via ControlNet network 223
- DeviceNet network I/O 193
- DeviceNet network 161
- distributed I/O 73
- memory size 25
- multiple controllers 247
- overview 21
- system
  - components 22
  - connection 23
- virtual chassis 22

**software**

- function block 22
- IOLinx 22, 191
- ladder logic 22
- RSLinx 28, 166, 195, 198, 203
- RSLogix 5000 196
- RSNetWorx 22
  - for ControlNet 196
  - for DeviceNet 173

**standard polling**

- mode 89

**startup**

- mode 25, 28
- system 253

**statistics**

- EtherNet/IP 63

**status**

- data 192
- indicators 257, 261
  - controller 85, 257
  - Ethernet module 259
  - LINK 259
  - NET 260
  - OK 260
- input
  - size 98
- input instance 98
- output
  - instance 98
- register bit 191

**system**

- components
  - SoftLogix 22
- overhead percentage
  - selecting 42
- overhead timeslice
  - Windows 247
- performance 26, 249, 252
- requirements 26
- restore
  - disable 240
  - Windows XP considerations 240
- startup 253
  - upload to the controller 41

**T****tag**

- analog
  - module 221
- remote
  - device 220
- SIM module 103

**task**

- defining 34
- events 35
- priority 35
- priority level 34
- Windows event 153

**TestTime utility****thread priorities****toggle**

- inputs 101

**trigger**

- event
  - task 156

**tuning****type**

- checking 114, 138
- RSLogix 5000 software 114

**U****UDP**

- disable 45
- enable 46

**upload**

- controller project 41
- physical address information 41

**user mode**

- configure 91
- high priority 26
- normal priority 26

**V****version information** 128**virtual chassis**

- SoftLogix 22

**Visual Studio** 117**W****Windows**

- blue screen 242
- consideration 241
- dwell time 243
- eoutbound event 149
- event
  - controller 149, 158
  - example 156
  - trigger controller 153
- object 241
- periodic task 244
- service pack 242
- SoftLogix
  - controller 243
- system overhead timeslice 247

**Windows XP considerations**

- system restore 240

**write schedule** 218**X****XML descriptions** 126





## Rockwell Automation Support

Rockwell Automation provides technical information on the Web to assist you in using its products.

At <http://www.rockwellautomation.com/support> you can find technical and application notes, sample code, and links to software service packs. You can also visit our Support Center at <https://rockwellautomation.custhelp.com/> for software updates, support chats and forums, technical information, FAQs, and to sign up for product notification updates.

In addition, we offer multiple support programs for installation, configuration, and troubleshooting. For more information, contact your local distributor or Rockwell Automation representative, or visit <http://www.rockwellautomation.com/services/online-phone>.

## Installation Assistance

If you experience a problem within the first 24 hours of installation, review the information that is contained in this manual. You can contact Customer Support for initial help in getting your product up and running.

United States or Canada	1.440.646.3434
Outside United States or Canada	Use the <a href="#">Worldwide Locator</a> at <a href="http://www.rockwellautomation.com/rockwellautomation/support/overview.page">http://www.rockwellautomation.com/rockwellautomation/support/overview.page</a> , or contact your local Rockwell Automation representative.

## New Product Satisfaction Return

Rockwell Automation tests all of its products to help ensure that they are fully operational when shipped from the manufacturing facility. However, if your product is not functioning and needs to be returned, follow these procedures.

United States	Contact your distributor. You must provide a Customer Support case number (call the phone number above to obtain one) to your distributor to complete the return process.
Outside United States	Please contact your local Rockwell Automation representative for the return procedure.

## Documentation Feedback

Your comments will help us serve your documentation needs better. If you have any suggestions on how to improve this document, complete this form, publication [RA-DU002](#), available at <http://www.rockwellautomation.com/literature/>.

Rockwell Automation maintains current product environmental information on its website at <http://www.rockwellautomation.com/rockwellautomation/about-us/sustainability-ethics/product-environmental-compliance.page>.

Rockwell Otomasyon Ticaret A.Ş., Kar Plaza İş Merkezi E Blok Kat:6 34752 İçerenköy, İstanbul, Tel: +90 (216) 5698400

**[www.rockwellautomation.com](http://www.rockwellautomation.com)**

### Power, Control and Information Solutions Headquarters

Americas: Rockwell Automation, 1201 South Second Street, Milwaukee, WI 53204-2496 USA, Tel: (1) 414.382.2000, Fax: (1) 414.382.4444  
Europe/Middle East/Africa: Rockwell Automation NV, Pegasus Park, De Kleetlaan 12a, 1831 Diegem, Belgium, Tel: (32) 2 663 0600, Fax: (32) 2 663 0640  
Asia Pacific: Rockwell Automation, Level 14, Core F, Cyberport 3, 100 Cyberport Road, Hong Kong, Tel: (852) 2887 4788, Fax: (852) 2508 1846

Publication 1789-UM002K-EN-P - January 2015

Supersedes Publication 1789-UM002J-EN-P - December 2012

Copyright © 2015 Rockwell Automation, Inc. All rights reserved. Printed in the U.S.A.