



## QUICK REFERENCE GUIDE



# Vaisala Surge Protector WSP152



- Superior 3-stage surge protection
- Tolerates up to 10 kA surge currents
- Both differential and common mode protection on each channel
- Filtering against HF and RF noise
- Two power channels ( $\pm 43V$ , 1.5A) and two data channels ( $\pm 13V$ , 0.16A)
- Designed for use with Vaisala USB cable 220782 for WXT/WMT products
- Adjustable mounting clamp provided for pole masts,  $\varnothing$  30 mm ... 102 mm

## DESCRIPTION

Vaisala Surge Protector WSP152 is a compact-size transient overvoltage suppressor. It is designed to be used with Vaisala WXT and WMT transmitters, to protect the host PC against surges entering through the USB port. For example, a nearby lightning strike may induce high-voltage surge not tolerable by the protection of the USB cable or port itself. Thus additional protection is needed in regions with frequent, severe thunderstorms, especially when long line cables ( $>30m$ ) are used.

Vaisala recommends using the surge protector in installations where USB cables are used for permanent connections. The surge protector is always recommended when there is an elevated risk of lightning strike. The WSP152 also provides additional filter for blocking the HF and RF interference induced into the cables in installations to radio transmitter masts, power line carrier towers etc.

The WSP152 has four channels, two dedicated for power lines and two for data lines. Each channel uses a three-stage protection scheme as follows: first there are discharge tubes, then voltage dependent resistors (VDR), and finally transient zener diodes. Between each stage there are either series inductors or resistors. Both differential and common mode protection is provided for each channel: across the wire pair, against the operating voltage ground, and against earth.

The WSP152 has a plastic housing with metal reinforcement. The WSP152 can be mounted on a wall, on the edge of a table, or to standard  $\varnothing$  30 mm ... 102 mm pole masts with an adjustable mounting clamp (provided).

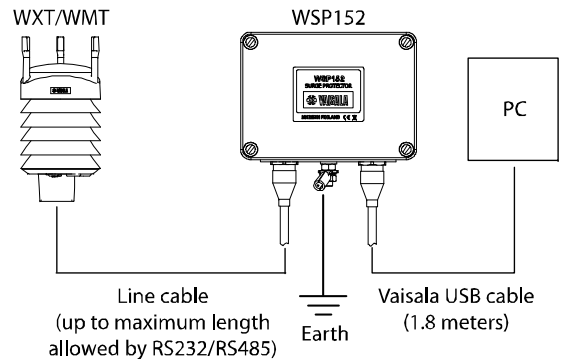
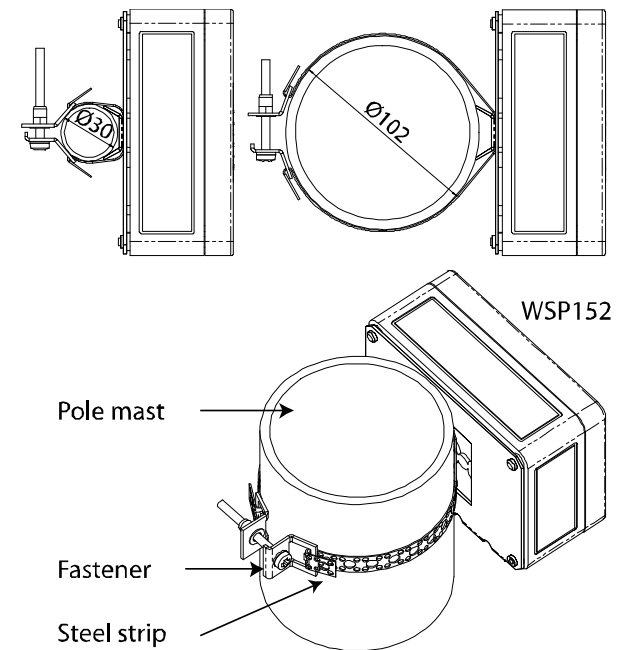

Figure 1 Operation principle

**CAUTION** The WSP152 should be placed no further from the PC than the Vaisala USB cable can reach (1.8 meters). Do not extend the cable.

## INSTALLATION WITH POLE MOUNTING



0803-061

Figure 2 Mounting WSP152 to Pole Mast

Figure 2 illustrates mounting of the WSP152 to a pole mast with the adjustable mounting clamp. For installation, follow the procedure below:

1. Fix the steel strip beneath the latch in the back of the WSP152 unit.
2. Fix the steel strip around the pole mast. You may shorten the strip to a suitable length.
3. Attach the steel strip ends to the fastener and fasten the unit to the mast by tightening the fastener's screw.
4. Connect an earthing cable to the connector in the middle of the WSP152.
5. Connect the USB cable to the M12 connector on the right side of the WSP152, and the line cable to the left side.

0803-059

## INSTALLATION WITH MOUNTING SCREWS

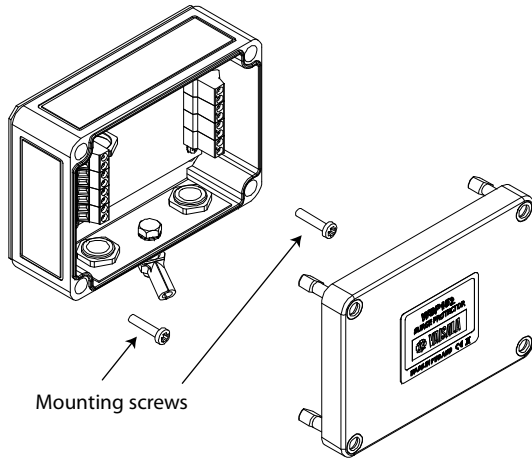

0803-060

Figure 3 Mounting WSP152 with Mounting Screws

Figure 3 shows how the WSP152 can be mounted on a wall or the edge of a table using mounting screws. Follow the procedure below:

1. Open the 4 plastic screws on the unit cover, and remove the cover.
2. Insert the mounting screws (not included) in the holes under the two lowermost plastic screws, and secure the unit to the desired mounting point (for example, to a wall or the edge of a table). Select the screws according to the material of the mounting surface.
- Note: The rear plate of the transmitter has threaded M4 holes, so you should use smaller screws.
3. Carefully reattach the enclosure cover with the four plastic screws.
4. Connect an earthing cable to the connector in the middle of the WSP152.
5. Connect the USB cable to the M12 connector on the right side of the WSP152, and the line cable to the left side.

## TECHNICAL DATA

Property	Description / Value
Allowed input voltage (across channel line pair and from line to GND, terminals #3)	Power channels: max. $\pm 43$ V Data channels: max. $\pm 13$ V
Allowed input common mode voltage	Any line to earth: max. $\pm 72$ V
Allowed throughput current	Power lines: max. 1.5 A Data lines: max. 0.16 A
Throughput resistance (per line)	Power lines: 0.3 ohms Data lines: 15 ohms
Turn-on voltage	Power channels: max. $\pm 60$ V Data channels: max. $\pm 16$ V
Surge current	To earth: max. 10 kA Differential: max. 5 kA
EMC surge tolerance	EN 61000-4-5 (4 kV, 2kA) IEEE C62.45 (6kV, 3kA)
Installation and maintenance work temperature	-40 ... +70°C (-40 ... +158°F)
Operating and storage temperature	-52 ... +70°C (-60 ... +158°F)
Environmental protection class	IP54
Dimensions (w × h × d) with connectors and mounting assembly	130 × 94 × 58 mm 130 × 120 × 69 mm
Weight	0.65 kg
Housing materials	Polycarbonate, stainless steel
Wire dimensions	Ø 0.4 - 1.7 mm (AWG 26 - 14)
Connectors	M12 / 8-pin Female M12 / 8-pin Male

## WIRING LAYOUT

Figure 4 illustrates the wiring layout inside the WSP152. For normal operation, it is not necessary to adjust the wiring. Colors and names are shown for the standard 8-wire M12-cable of WXT/WMT devices.

The USB cable does not provide heating power for the device, only the operating power (max. 150mA).

Either RS-232 or RS-485 can be used (depending on WXT/WMT configuration) with no need of wiring changes on either side.

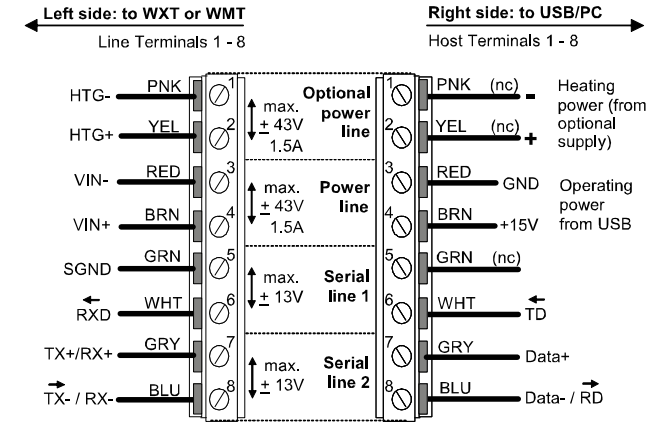

0804-001

Figure 4 Wiring Layout of Component Board

## DIMENSIONS

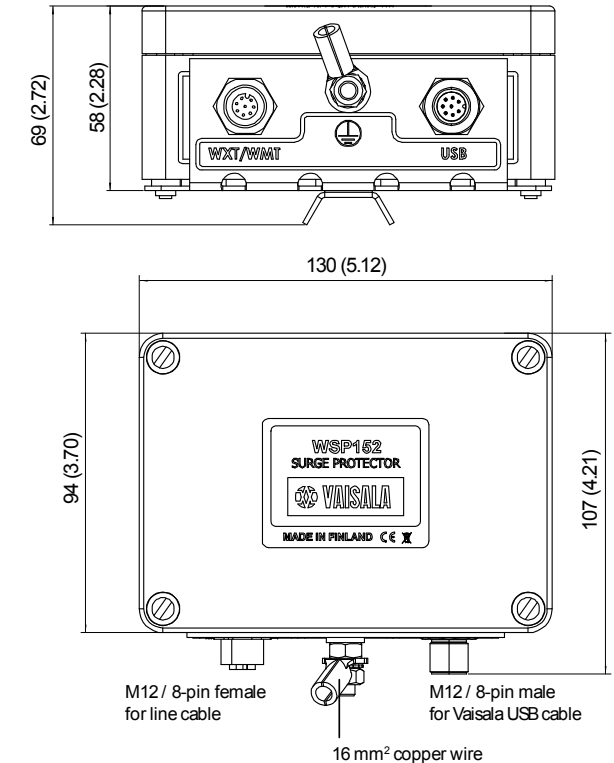

0611-028

Figure 5 Dimensions in mm (inch)