

SKF Multilog On-line System IMx-Rail



User Manual Supplement
Part Number **15V-090-00082-100**
Revision **B – September 2020**



Read this manual carefully before using the product. Failure to follow the instructions and safety precautions in this manual can result in serious injury, damage to the product or incorrect readings. Keep this manual in a safe location for future reference.

Copyright © 2018 by SKF Group
All rights reserved.

SKF Sverige AB
Aurorum 30, 977 75 Luleå, Sweden
Telephone: +46 (0) 31 337 10 00

® SKF is a registered trademark of the SKF Group.

Android is a trademark of Google LLC.

The Bluetooth® word mark and logos are registered trademarks owned by Bluetooth SIG, Inc. and any use of such marks by SKF is under licence.

iOS is a trademark or registered trademark of Cisco in the US and other countries.

All other trademarks are the property of their respective owners.

The contents of this publication are the copyright of the publisher and may not be reproduced (even extracts) unless prior written permission is granted. Every care has been taken to ensure the accuracy of the information contained in this publication but no liability can be accepted for any loss or damage whether direct, indirect or consequential arising out of the use of the information contained herein. SKF reserves the right to alter any part of this publication without prior notice.

Patents: US 4,768,380 • US 5,633,811 • US 5,679,900 • US 5,845,230 • US 5,852,351 • US 5,854,553 • US 5,854,994 • US 5,870,699 • US 5,907,491 • US 5,992,237 • US 6,006,164 • US 6,124,692 • US 6,138,078 • US 6,199,422 • US 6,202,491 • US 6,275,781 • US 6,301,514 • US 6,437,692 • US 6,489,884 • US 6,513,386 • US 6,633,822 • US 6,789,025 • US 6,792,360 • US 7,103,511 • US 7,697,492 • WO/2003/048714

Product Registration

Please take a moment to [register your product](#) to receive exclusive benefits offered only to our registered customers, including technical support, tracking your proof of ownership, and staying informed about upgrades and special offers. (Please visit our website for more details on these benefits.)

General Product Information

General information such as datasheets and catalogues are published on the [Condition Monitoring Systems](#) site on SKF.com. Supporting product information can also be downloaded from the [SKF Technical Support](#) self-service web portal.

Product Support Contact Information

[Repair and Calibration Services](#) – Submit a [Return Authorization \(RA\) request](#) to arrange for repair or calibration of your product. You will receive an RA number and shipping instructions usually within 48 business hours.

[Product Support Plans \(PSP\)](#) – SKF offers annual renewal Product Support Plans (PSP) on many condition monitoring products in an effort to extend the life of your product. Software and firmware updates are an exclusive entitlement to PSP customers. Additional benefits include product repair, Annual Preventative Maintenance (APM) and certified calibration - all of which are all carried out on a priority-basis. Enjoy unlimited technical support and access to after-hours support for machine- and process-critical applications.

[Product Sales](#) – For information on purchasing condition monitoring products, services and support on products out of warranty, please contact your [local SKF sales office](#) or [distributor](#).



Technical Support – SKF's Technical Support Group can be reached during normal business hours via phone, e-mail and live chat. Always check the [self-service web portal](#) before contacting your nearest Technical Support Group (TSG) to see if the answer is already published. You may search the vast knowledge base within the self-service web portal for answers to commonly-asked questions (FAQ), how-to articles, technical specs, installation and user manuals, best practices and

Table of contents

1	Product description	7
1.1	Introduction to the SKF Multilog On-line System IMx-Rail	7
1.2	SKF Multilog On-line System IMx-16Plus	8
1.2.1	LTE/GSM (mobile) data module	8
1.2.2	Local network RJ45 or Wi-Fi module.....	8
1.2.3	GPS module (optional / external).....	8
1.2.4	Modbus interfacing to external systems.....	9
1.3	DC-DC power module.....	9
1.4	Enclosure	9
2	Installation and operating instructions	10
2.1	Introduction	10
2.2	System communications.....	11
2.3	SKF Multilog On-line System IMx-Rail enclosure mounting	11
2.4	Power requirements.....	12
2.5	On train cabling.....	13
2.5.1	Cable glanding	14
2.6	GPS module connection notes	15
2.6.1	GPS (location data) module.....	15
2.6.2	RS485 Modbus bus termination	15
2.7	Commissioning and Maintenance	16
2.7.1	System commissioning and security.....	16
2.7.2	Hardware Maintenance.....	16
2.7.3	Performance over Time	16
3	Product specifications.....	17
3.1	Product labelling	17
3.2	EU Declaration of Conformity	18
3.3	SKF Multilog On-line System IMx-Rail	19
3.3.1	Environmental	19
3.3.2	Power	19
3.3.3	Analogue inputs	20
3.3.4	Digital inputs.....	20
3.3.5	Digital outputs	20
3.3.6	Analogue measurement.....	20
3.3.7	Digital measurement	20

3.3.8	Signal processing.....	20
3.3.9	Interfaces.....	20
3.3.10	Storage capacity	21
3.3.11	Data processing memory	21
3.3.12	Certifications	21
3.3.13	Quality control	21
3.4	Connector details for SKF Multilog IMx-Rail.....	22
3.4.1	IMx-Rail	22
3.4.2	IMx-16Plus top end cap	23
3.4.3	IMx-16Plus bottom end cap	23
3.5	Enclosure mechanical drawings	24
3.6	GPS module mechanical drawings.....	26
4	Electrical waste	27
	Appendix A Limited Warranty.....	29

1 Product description

1.1 Introduction to the SKF Multilog On-line System IMx-Rail

The SKF Multilog On-line System IMx-Rail is an online condition monitoring system specifically designed for railway applications and consisting of a 16-channel monitoring device complete with mobile and LAN data interfaces (IMx-16Plus), pre-installed in an outer protective enclosure.

 **Important note:** *As this is a user manual supplement, please also refer to the separate IMx-16/16Plus user manual, which provides further important information and guidance. Reference: SKF Multilog IMx-16/IMx-16Plus User Manual.*

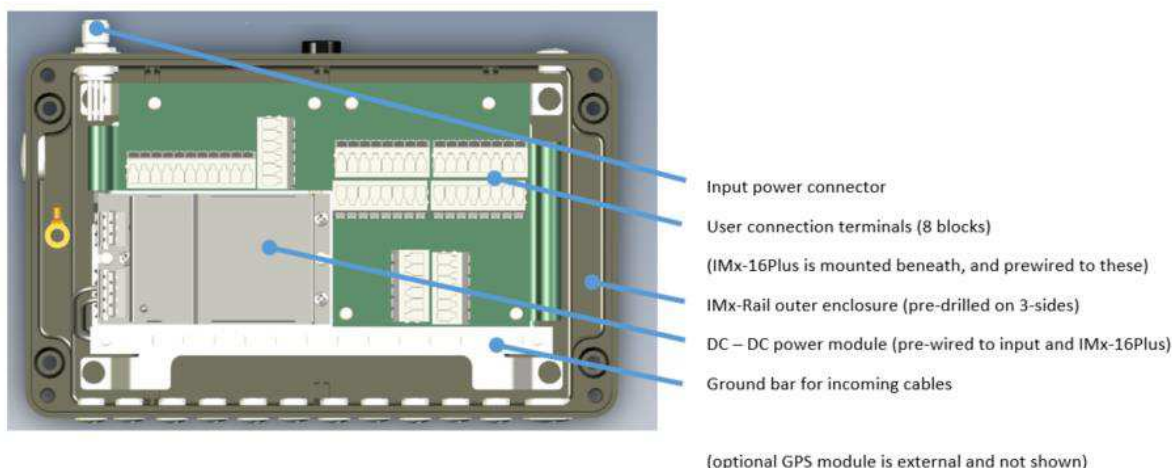

Figure 1 SKF Multilog IMx-Rail – arrangement of main system components

The outer enclosure has been selected to allow the system to be mounted in either an internal or external location appropriate to the equipment/bearings being monitored:

- Bogie mounting
- Car chassis mounting
- Internal car/coach mounting

Each of the main component parts of the system, **Figure 1**, are described in the following sections, **1.2** to **1.4**.

1.2 SKF Multilog On-line System IMx-16Plus

The IMx-16Plus is a second generation 'IMx-8' capable of interfacing to 16 analogue inputs (eight constant current accelerometers or voltage inputs and a further eight that in addition have, PT1000 compatibility for temperature monitoring).

There are four digital inputs for speed, it is mobile data capable and has RS485 and LAN interfaces. Note that mobile data and LAN (RJ45 or Wi-Fi) connectivity are all alternative infrastructures to connect the IMx-Rail to the wider cloud network and cannot be used simultaneously. Refer also [Installation and operating instructions](#).

In an IMx-Rail device, it is supplied pre-fitted in the Rail enclosure and pre-wired to the lid mounted antenna and to easily accessible user terminals, above the unit. These encompass all the terminals available on the IMx-16Plus itself, such as analogue inputs, digital I/O and RS485. The RS485 link can interface, by Modbus RTU, to an external GPS module, [1.2.3](#).

1.2.1 LTE/GSM (mobile) data module

A built-in module provides a wireless mobile data connection (LTE/GSM). It can work world-wide and provides connectivity to @ptitude Observer software. Mobile data functionality requires an activated SIM card or eSIM. The enclosure lid carries an integral radio antenna, no connection to an additional, external antenna is required.

The choice between using a mobile data connection or a Wi-Fi/RJ45 LAN connection, is part of the IMx-Rail configuration.

1.2.2 Local network RJ45 or Wi-Fi module

A built-in Wi-Fi module provides an 802.11n, Wi-Fi communication interface (2.4 GHz) so that, where available, a local train wireless network can be used as the first stage of connectivity to @ptitude Observer software, rather than a hard-wired LAN or the mobile network. Wi-Fi is combined in the lid mounted radio antenna, no connection to an additional, external antenna is required.

1.2.3 GPS module (optional / external)

The IMx-Rail can use train position data to collate with the condition monitoring measurements and to support the track monitoring functionality. The GPS data is requested by the IMx-Rail, acting as a Modbus RTU master on the RS485, two wire serial interface. Connections for this are available amongst the terminals provided.

An optional GPS module is available. This has an integral antenna, but the module itself must be fitted external to the IMx-Rail enclosure.

PRODUCT DESCRIPTION

DC-DC power module



1.2.4 Modbus interfacing to external systems

Modbus communication is a commonly used protocol for exchanging information between systems, often from different suppliers or providers. Note that Modbus TCP/IP is not available if the mobile data connection is in use. Refer to the IMx-16/16Plus user manual for further information on the Modbus capabilities.

1.3 DC-DC power module

This module is included so that the IMx-Rail can be powered directly from the train supply (24 to 110 V DC). Two IMx-Rail variants are available to service that input voltage range:

CMON 4116-R-24: 24 V DC nominal (9 to 36 V DC)
CMON 4116-R-110: 110 V DC nominal (43 to 160 V DC)

The power module provides stable, isolated power at 24 V DC, to the IMx-16Plus. It protects it from any incoming voltage transients whilst at the same time preventing any disturbance to the train power bus system, from the IMx-Rail.

The power module is pre-wired to both the incoming supply (at the power connector) and the IMx-16Plus module, internal to the IMx-Rail.

1.4 Enclosure

An outer enclosure houses all the electronics, provides cable gland areas pre-prepared for the sensor, GPS and other cables and the lid incorporates a single antenna that supports the internal mobile data and Wi-Fi modules. The 21 cable entries provided are all supplied fitted with blanking plugs. See also [Enclosure mechanical drawings](#). As shown in [Figure 1](#), on removing the enclosure lid a ground bar and terminals for the connection of train cabling are easily accessed.

The IMx-Rail is designed to be mounted on either the train bogie, train car chassis or internally in a car/coach as appropriate to the equipment and bearings being monitored.

2 Installation and operating instructions

2.1 Introduction

At the heart of the IMx-Rail is an IMx-16Plus. This is an updated version of the ‘IMx-8’ with additional sensor capacity (increased number and wider range of sensor types) and with the additional interfaces needed for rail applications such as GPS, mobile data and Wi-Fi. An overview of these extended capabilities is shown in [Figure 2](#) and details of the specific features and capabilities follow.

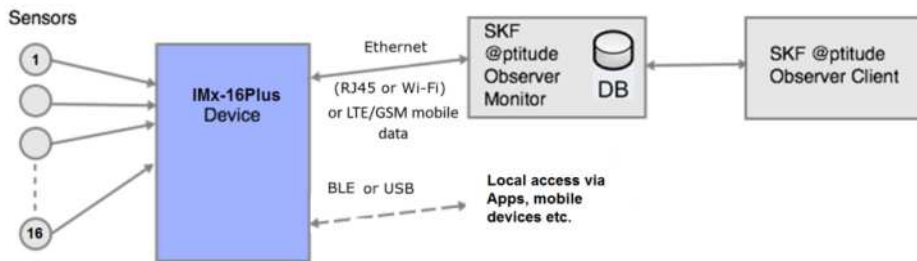

Figure 2 SKF Multilog IMx-Rail connections overview

Note that mobile data and LAN (Wi-Fi or RJ45) connectivity are alternative infrastructures to connect the IMx-Rail to the wider cloud network and cannot be used simultaneously.

Before beginning an installation, it is important to assess and evaluate the location where the system is to be installed and to plan how the installation should look after it has been completed. Make a detailed layout of the equipment and note distances between components and the networks to which it should connect. Specify the configuration requirements of each interface, for example network configuration such as IP addresses and subnet mask for a LAN connection.

Amongst other things, consider the lengths of all cables, their routing, where electrical power for the unit can be sourced and any interfaces to the train systems. Good and thorough planning is the basis for a successful installation and system implementation.

2.2 System communications

The communications setup or mode, determines how the device will communicate with the wider system. There are 2 main alternative arrangements that can be used with the IMx-Rail:

- Server initiated (@ptitude Observer initiated communication)
- Client-Server (the IMx-Rail is the initiator of the communication)

These are alternatives for @ptitude Observer/IMx communication, illustrated diagrammatically in [Figure 2](#).

Whilst in general, the different network connection possibilities ([1.2.1](#) to [1.2.2](#)) can be considered as alternatives, there are limitations on the permissible combinations of network connection method and communication mode:

1. Server initiated, requires a server installed on a local network (with RJ45 or Wi-Fi connection).
2. Mobile data connectivity is only supported in Client-Server mode (device initiated communications).

The choice between using a mobile data connection or a LAN connection (RJ45 or Wi-Fi), is part of the IMx-Rail configuration.

2.3 SKF Multilog On-line System IMx-Rail enclosure mounting

When selecting a location for the device, inside the coach or externally on the coach chassis or bogie, make sure to consider the following aspects:

- Position it to minimise vibration and to keep clear of high voltage equipment.
- Avoid unnecessary exposure to radiant heat or strong magnetic fields.
- Choose a location convenient for cable routing, to and from the enclosure.
- With unobstructed access and clearance for opening the lid.
- Suitable for an enclosure of this size and weight.
- That will accommodate all the required fixing points.

Refer section [3.5](#) and [Figure 5](#) for the enclosure dimensions and fixing centres. They allow the enclosure to be directly mounted, but if needed, an installation specific mounting bracket can utilise these fixings.

2.4 Power requirements

The SKF Multilog IMx-Rail is designed to be powered from the train's DC supply. Nominal supply voltages between 24 and 110 V DC are accommodated by appropriate choice of IMx-Rail model (nominal 24 V DC or 110 V DC input). The supply to the IMx-Rail device should be protected by an appropriately rated fuse, refer [3.3.2](#).

The incoming DC train supply, is connected via the 4-pole power connector mounted on the side of the IMx-Rail enclosure, [Figure 1](#). The pin designations and details for this connection are as shown in [Table 1](#) below, two pins are available for each functional connection:

Table 1 DC input power connection

Pin	Description
1 and/or 4	Supply 0V (Internally connected to -Vin, power module terminal 2)
2 and/or 3	Supply + (Internally connected to +Vin, power module terminal 1)

A mating M12, A-coded, IEC 61076-2-101 cable mounting connector is supplied with the IMx-Rail and further quantities can be ordered under the following reference:

- CMON 4143: Socket power supply connector for SKF Multilog IMx-Rail

This has push-in connections and accommodates an external cable diameter of 4 to 8 mm. Conductor cross sections (without ferrule) can be in the range 0.14 mm² to 0.75 mm² (26 to 18 AWG). On assembly, after fitting into the rear part of the connector, the exposed individual conductor length should be 24 mm with 8 mm stripped back for insertion.

Internally the incoming supply via this connector is pre-wired to the power module and the output of that power module is pre-wired to the IMx-16Plus module.

On the top face of the power module there is a single (green) 'output on' LED but no user controls or adjustments.

Refer also to the important safety warnings on the following page.

Note that (except in circumstances where the three relay outputs and LTE/GSM functions are all enabled), the IMx-16Plus also supports PoE (Power over Ethernet). This can be used as either a single or as a redundant power source, refer also to the SKF Multilog IMx-16/IMx-16Plus User Manual.

Important safety warnings:



In some countries, the installer must be certified to connect equipment, such as an IMx-Rail, to train systems.



Make sure that the power is disconnected before the installation begins.



*To connect the IMx-Rail to the DC power supply, use cable of the following standard or better:
FKLK 3 x 1.5 mm² (16 AWG) or EKLK 3 x 1.5 mm² (16 AWG) or corresponding, with minimum voltage requirement 300 V and temperature range of -40 to +70 °C (-40 to +158 °F).*



The system power supply must be provided with an appropriately positioned, clearly labelled full pole isolator or switch that can be used to isolate and lock-out power from the IMx-Rail unit during installation, maintenance or modification work. The switch must be labelled "IMx-Rail" or similar, with clear identification of which IMx, if multiple units are deployed. The On/Off position must be clearly marked.

The supply scheme should also incorporate suitable fusing or circuit breakers for the protection of the supply cable being used. Protection for the IMx-16Plus is provided within/by the power module.

2.5 On train cabling

The IMx-Rail is appropriately prepared to accept train cabling via three of the enclosure walls, refer section 3.5 and Figure 6 to Figure 8. The enclosure provides a total of two entries for M20 x 1.5 glands and 19 entries for M12 x 1.5 glands for the following functions:

- Analogue sensor cables
- Speed sensor (digital signal) cables
- An Ethernet cable
- GPS module cable
- RS485 and relay connections

These cable entries are pre-fitted with blind plugs.

Important safety warnings:

Only remove the fitted blind plugs where it is necessary to accommodate a cable. Any unused cable entries must remain closed off. Always use an appropriate cable gland to accommodate the cable.

Within the enclosure a grounding bar is provided for use in conjunction with the incoming cabling. Important additional information and guidance in respect of glanding, grounding and cabling (sensor, Ethernet and RS485) can be found in the SKF Multilog IMx-16/IMx-16Plus User Manual.

The user connection terminals, [3.4.1](#), are of a lever, push in type (tool-free design). Cable entry is vertical (at right angles to the underlying PCB). These terminals accept conductors in the range 0.2 to 4 mm² (24 to 12 AWG) with an insertion length of 9 to 11 mm. For cable/wire ends, bootlace ferrules or cord end terminals are recommended.

When routing or arranging cabling within the IMx-Rail enclosure avoid, where possible, routing the analogue sensor cabling directly over the DC-DC power module.

2.5.1 Cable glanding

The glands used with the IMx-Rail should be chosen to maintain the enclosure IP rating and be appropriate for a railway environment and the cable type. As mentioned above, [2.5](#), the IMx-Rail is prepared for a mix of M12 x 1.5mm and M20 x 1.5mm glands.

The M12 x 1.5 gland SKF supply with the optional GPS module, [3.6](#), has the following specifications:

Application:	Designed to withstand high pressure wash-downs Corrosion resistant, stable
Material:	Nickel-plated brass
IP rating:	IP 68 - 10 bar IP 69

It is recommended that all glands used with IMx-Rail are of an equivalent or higher specification.

2.6 GPS module connection notes

2.6.1 GPS (location data) module

An external GPS module is available as an option. When fitted, GPS data is requested by the IMx via Modbus RTU over an RS485, 2-wire connection. On this interface the IMx is the master device and the GPS module is the slave device.

The GPS module comes with a 5-m cable allowing it (with its integral antenna) to be fitted outside of the IMx-Rail enclosure in an appropriate location that will allow it to acquire satellite tracking.

The GPS module is connected to the user terminals provided, refer [Table 2](#) below and section [3.4.1](#). Note that the RS485A (A/B) terminals must be used.

Table 2 GPS module connections to IMx-16Plus

Wire colour	Description	IMx-Rail terminal
Brown	GPS module power	GPS PWR
Black	RS485 A	RS485A A
White	RS485 B	RS485A B
Blue	Module 0V	GND
Grey	Not used	-

Refer note, below, about bus termination.

The GPS module has two status indicators, visible on the front face of the module:

Green flashing: Power on

Amber flashing: Modbus communications activity

2.6.2 RS485 Modbus bus termination

If an IMx-Rail device is placed first or last in the bus chain, then an external bus termination resistor must usually be connected to it. (Note: there is no built-in termination that can be activated by configuration).



Important – When connecting the optional GPS module to the IMx-16Plus, do not fit a termination resistor.

2.7 Commissioning and Maintenance

2.7.1 System commissioning and security

System commissioning and troubleshooting is supported by the SKF Multilog IMx Manager, software. This is an SKF app for both Android and iOS devices and is available from the relevant app store. The app provides features to manage and configure the IMx system and to visualise measurement data:

Important additional information and guidance in respect of system commissioning and security can be found in the SKF Multilog IMx-16/IMx-16Plus User Manual.

2.7.2 Hardware Maintenance

The IMx-Rail hardware, i.e. IMx-16Plus, power supply and its associated sensors, are virtually maintenance free, though a yearly inspection of all installed equipment is advised. Good practice is to use the IMx Manager app to generate and compare annual SAT (Site Acceptance Test) reports.

The IMx-16Plus device does not need to be opened for hardware maintenance or inspection. Refer to the Troubleshooting section of the SKF Multilog IMx-16/IMx-16Plus User Manual, for guidance on checks that can be made and where necessary contact SKF TSG for advice.

Any repairs to an IMx-Rail device should only be carried by an SKF repair centre. They can source all required replacement parts, including the **DC-DC power module** and antenna:

CMON 4140: 24V Power Supply for IMx-Rail (for CMON 4116-R-24)

CMON 4141: 110V Power Supply for IMx-Rail (for CMON 4116-R-110)

CMON 4142: External antenna for SKF Multilog IMx-Rail/IMx-16Plus

2.7.3 Performance over Time

No significant performance degradation over time, is expected for the IMx-Rail hardware.

3 Product specifications

3.1 Product labelling

Externally on one end wall and internally on the inside of the enclosure lid, a manufacturing data label confirms product and company information, CE marking, WEEE marking and RoHS compliance. The QR code contains the product information shown alongside it. The supply voltage for the device (either a nominal 24 or 110 V DC) is prominently shown:

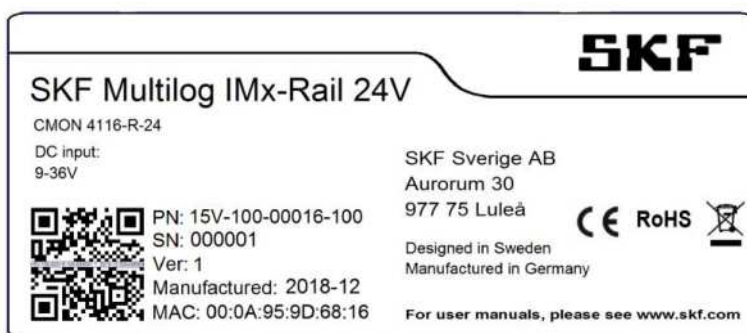

Figure 3 Manufacturing data label 24 V version

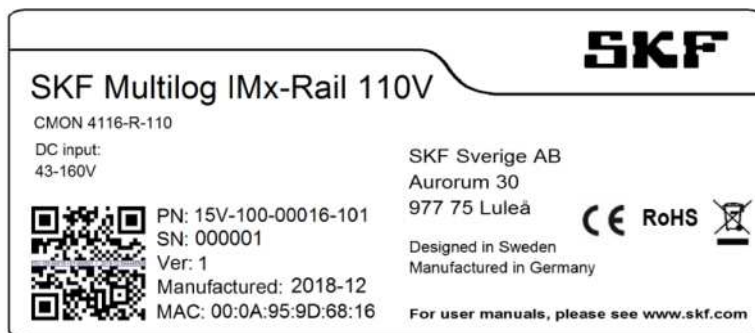



Figure 4 Manufacturing data label 110 V version

Refer to [3.3.12](#) (detailed product specifications) for a complete listing of compliances and certifications.

3.2 EU Declaration of Conformity





EU Declaration of Conformity

Manufacturer: SKF Sverige AB
Address: Aurorum 30, 977 75 Luleå
Country: Sweden

Type of Equipment: Condition Monitoring On-line System

Part Number	Part Name
CMON 4116-R-24	SKF Multilog IMx-Rail 24V
CMON 4116-R-110	SKF Multilog IMx-Rail 110V

The manufacturer declares under sole responsibility that the products listed above conforms to the requirements of the following directives:

Radio Equipment Directive	(RED) 2014/53/EU
Restriction of Hazardous Substances	(ROHS 3) 2015/863/EU

Harmonised European standards which have been applied:

EN IEC 61000-6-4	Emission standard for industrial environments
EN 50121-3-2	Emission and immunity aspects of EMC on railway rolling stock
ETSI EN 301 489-1	Common Technical requirements
ETSI EN 301 489-17	Specific conditions for Broadband Data Transmission Systems
ETSI EN 301 489-52	Specific conditions for Cellular Communication Mobile and portable (UE) radio and ancillary equipment
ETSI EN 300 328	Data transmission equipment operating in the 2,4 GHz ISM band
ETSI EN 301 908-1	IMT cellular networks



Helena A Karlsson
Development Manager

12 February 2020

SKF Sverige AB
 Aurorum 30 • 977 75 Luleå • Sweden
 Tel: +46 (0)31 337 1000 • Support: +46 (0)31 337 6500
 Fax: +46 (0)920 134 40 • www.skf.com



3.3 SKF Multilog On-line System IMx-Rail

3.3.1 Environmental

- Size (H x W x D): 260 x 160 x 90 mm (*10.24 x 6.30 x 3.54 in.*)
Dimensions do not include antenna and glands/cable exits
The antenna protrudes only 32 mm but for improved reception, avoid it being closer than 500 mm to other metal structures
- Weight: 8 725 g (*19.2 lb*)
- IP ratings:
 - Multilog IMx-Rail: IP66/IP67
 - Optional GPS module: IP69K
- Temperature ranges
 - Operating: -40 to +65 °C (*-40 to +149 °F*)
 - Storage: -50 to +85 °C (*-58 to +185 °F*)
- Humidity: 95% (relative) non-condensing
- Measurement category II
- Pollution degree 2
- Maximum altitude: 2 000 m (*6 562 ft*)
- Vibration tolerance:
 - 4 – 13.2 Hz 1 mm
 - 13.2 – 100 Hz 0.7 gNumber of axes: 3 mutually perpendicular

3.3.2 Power

- For information on Power over Ethernet refer IMx-16/16Plus user manual
- Input power connector: An (M12, A-coded, IEC 61076-2-101 cable mounting) connector is supplied
- Power module variants for 24 V DC and 110 V DC (both nominal)
- 24 V DC module:
 - Input voltage range: 9 to 36 V DC
 - Fuse at 2 A slow blow, T2AL
 - Protection against over voltage (input surge voltage 1 s maximum)
 - 50 V DC maximum
 - Under voltage lock-out circuit
 - 8 V DC typical
- 110 V DC module:
 - Input voltage range: 43 to 160 V DC
 - Fuse at 1 A slow blow, T1AL
 - Protection against over voltage (input surge voltage 1 s maximum)
 - 170 V DC maximum
 - Under voltage lock-out circuit
 - 40 V DC typical
- Common power module specifications are as follows:
 - Inrush current 15 A typical
 - Output 24 V DC, 20 W, typical efficiency 87%
 - EN 50155 approval for railway applications
 - Safety approvals: IEC/EN 60950-1 and UL 60950-1
 - Input filter meeting EN 55032, class B (emissions)

- Aluminium cased
- Isolated (input/output, input/case)
- Continuous short circuit protection with automatic recovery

3.3.3 Analogue inputs

- 16 analogue single ended inputs, referenced to chassis/enclosure ground.
- Channels 9 to 16 can connect to additional sensor types
 - PT1000, temperature probes (2-wire connection)
- For further information refer IMx-16/IMx-16Plus user manual

3.3.4 Digital inputs

- Four digital inputs, non-isolated, referenced to chassis/enclosure ground
- For further information refer IMx-16/IMx-16Plus user manual

3.3.5 Digital outputs

- Three: System status (RS), Warning and Alarm (R1 and R2)
- For further information refer IMx-16/IMx-16Plus user manual

3.3.6 Analogue measurement

- 24-bit A/D conversion, one A/D converter for each channel
- Maximum sampling frequency: 102.4 kHz (though lower for event capture)
- Frequency range: from DC to 40 kHz
- For further information refer IMx-16/IMx-16Plus user manual

3.3.7 Digital measurement

- For further information refer IMx-16/IMx-16Plus user manual

3.3.8 Signal processing

- Event capture mode
 - Data storage on time, associated measurement value or alarm state
 - Run cycle mode (used for rail track monitoring)
- Rail Track monitoring
 - Supports @ptitude Observer's Metro and Mainline modes
 - Measurements linked to GPS and speed data (as appropriate)
 - Continuous capture between two locations or when triggered
 - At least 9.5 minutes of data at 1 kHz Fmax.
 - Ready for new capture after 15 s (2-channels used)
- For further information refer IMx-16/IMx-16Plus and/or @ptitude Observer user manuals

3.3.9 Interfaces

- Mobile data or Ethernet LAN (RJ45 or Wi-Fi)
 - LTE/GSM/Wi-Fi antenna is integral to the enclosure lid
 - Firmware configurable support for micro-SIM or eSIM
 - Micro-SIM card holder (top end cap of IMx-16Plus)
 - One RJ45 port, 100 Mbit/s

- The lid mounted antenna / IMx-Rail combination supports the following frequencies and standards:
 - AMPS 850 MHz
 - GSM 900 MHz
 - 3G UMTS 2.1 GHz
 - Wi-Fi 2.4 GHz
 - DCS 1800 MHz
 - PCS 1900 MHz
 - LTE 2.6 GHz
 - 4G/LTE 791-960, 1710-2690 MHz

Note that Bluetooth support in the IMx-16Plus is via a USB Bluetooth LE (Low Energy) dongle, not the antenna.

The antenna does not support the 699-791 MHz range (typically N. American LTE).

- GPS location data provided by an external/optional GPS module
- RS485 2-wire serial interface, Modbus RTU
- USB Type-A and Mini-B interfaces
- For further information refer IMx-16/IMx-16Plus user manual

3.3.10 Storage capacity

- For further information refer IMx-16/IMx-16Plus user manual

3.3.11 Data processing memory

- For further information refer IMx-16/IMx-16Plus user manual

3.3.12 Certifications

- Calibration traceable to BIPM
- EMC:
 - EN/IEC 61000-6-4, EN 50121-3-2, ETSI EN 301 489-1, -17
- CE certified:
 - 2014/53/EU (RED) including ETSI EN 300 328, ETSI EN 301 908-1
- FCC certified (North America):
 - FCC Part 15B 107/109, ICES-003, FCC Part 15C 15.247 (d), RSS-447 sect. 5.55.5
 - FCC Part 22H 917/RSS-132 sect. 5.5, FCC Part 24E 328/RSS-133, FCC Part 25.53(h)/RSS-139
 - Refer to the IMx-16Plus certifications section of the SKF Multilog IMx-16/IMx-16Plus User Manual for additional FCC compliance information
- Compliant with railway standards EN 50155:2017 and EN 50121-3-2
- See also [3.3.2](#), for specific power module certifications

BIPM: International Bureau of Weights and Measures

3.3.13 Quality control

- SKF Sverige AB's Condition Monitoring Centre Luleå is ISO 9001:2015 certified

3.4 Connector details for SKF Multilog IMx-Rail

3.4.1 IMx-Rail

Table 3 IMx-Rail user connection terminals

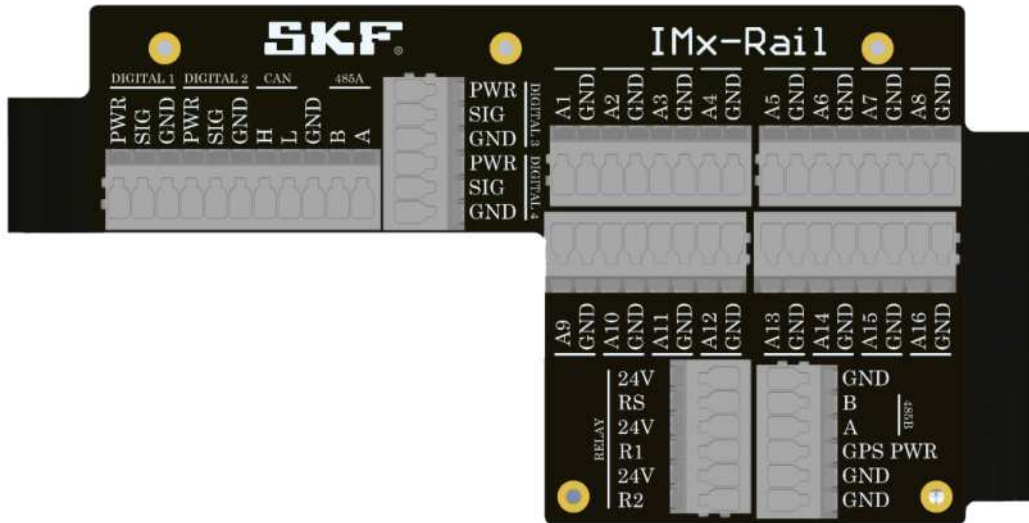

Terminal	Description
Digital1-4	4 digital inputs (Ground, Signal, Power terminals for each)
CAN L/N	CAN bus for vehicle systems (Currently no firmware support)
GND	Ground connection for use as required by RS485 and/or CAN
485A A/B	RS485 2-wire A and B terminals (Modbus RTU for GPS module)
A1-A16	Analogue inputs 1 to 16* (Analogue, Ground terminals for each) Connect signal to A terminal
24V	24 V DC power for relay coil (One for each relay driver output)
RS/R1/R2	Three relay driver output connections
GND	Three GND connections (unallocated/general use)
GPS Power	This can be used to power a GPS module connected to 485A
485B A/B	Not used

* A9 to A16 can be used for 2-wire PT1000 temperature sensors

3.4.2 IMx-16Plus top end cap

Table 4 IMx-16Plus top end cap connections

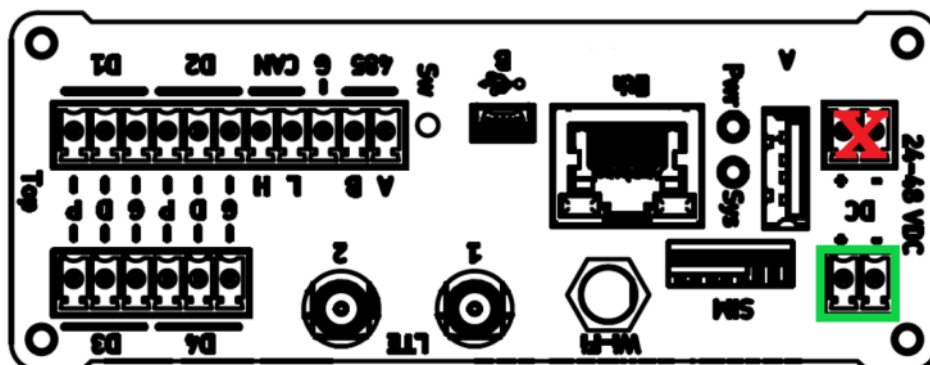

All terminals and antenna connections available on the IMx-16Plus top end cap are pre-wired to the DC supply, upper user terminals or antenna, as appropriate to each. Only those items listed below are not, so pre-wired:

Item	Description
SIM	micro-SIM card slot (see note on SIM card orientation, below)
A	USB A, host interface (Bluetooth dongle normally fitted here)
Eth	RJ45 Ethernet connector (for Power over Ethernet see 2.4)
USB B	USB mini-B connector*, service interface. *Note that for ease of access a, USB mini-B to USB A receptacle, cable is pre-fitted.
LED	Pwr – Power (green, normal: on), Sys – System (red, normal: off)
Sw	Switch/push button - rescue button (enters maintenance mode)

Note that (as shown), in the IMx-Rail the IMx-16Plus is mounted 'upside down'. That is: the top end cap is at the power connector end of the IMx-Rail, but the DC input to the IMx-16Plus is away from that connector. Be aware of that orientation when locating the RJ45 connector, SIM card slot etc. When fitting the SIM card, it must be orientated as follows;

- Contacts up and with the card notch across the left and outer edges
- In this instance. up and left refer to the 'inverted view' illustrated above

3.4.3 IMx-16Plus bottom end cap

All terminals available on the IMx-16Plus bottom end cap are pre-wired to the upper user terminals in the IMx-Rail.

3.5 Enclosure mechanical drawings

The SKF Multilog IMx-Rail is housed in a (black) powder coated, die cast aluminium enclosure. It has overall dimensions of 260 mm long, 160 mm wide (excluding glands, cabling and connector) and is 90 mm deep with fixing centres of 238 x 111 mm, refer [Figure 5](#). The four mounting/fixing holes are 6.5 mm diameter (clearance on M6).

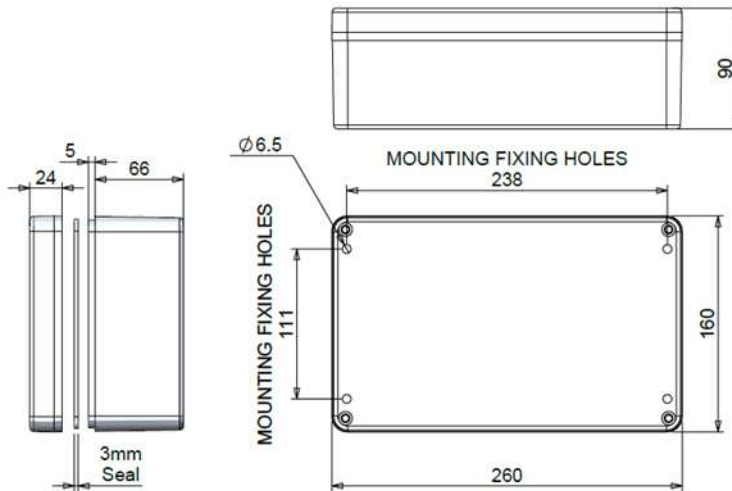



Figure 5 IMx-Rail enclosure drawing

Important safety warning:

 *Always utilise all provided fixing points to secure the enclosure to the mounting surface.*

The low profile, circular antenna fitted to the enclosure lid, is 148 mm in diameter and protrudes 32 mm above.

Three walls of the enclosure (two long and one short) are pre-fitted with blind plugs, refer [Figure 6](#), [Figure 7](#) and [Figure 8](#) for the drilling pattern/arrangement.

These (21) cable entries are supplied sealed, only remove the blind plug from entries that will be actively used for cabling. Always then use an appropriate cable gland.

Depending on the actual gland used, an M20 gland will typically protrude no more than 29 mm from the enclosure, but in all cases, a further allowance must be made for the cabling used. In addition, note that on the back long wall, sufficient clearance must be allowed for the power connector and mating cable, the connector location is coloured red in [Figure 7](#). The M12 plug (without mating connector) protrudes approximately 15 mm from the enclosure.

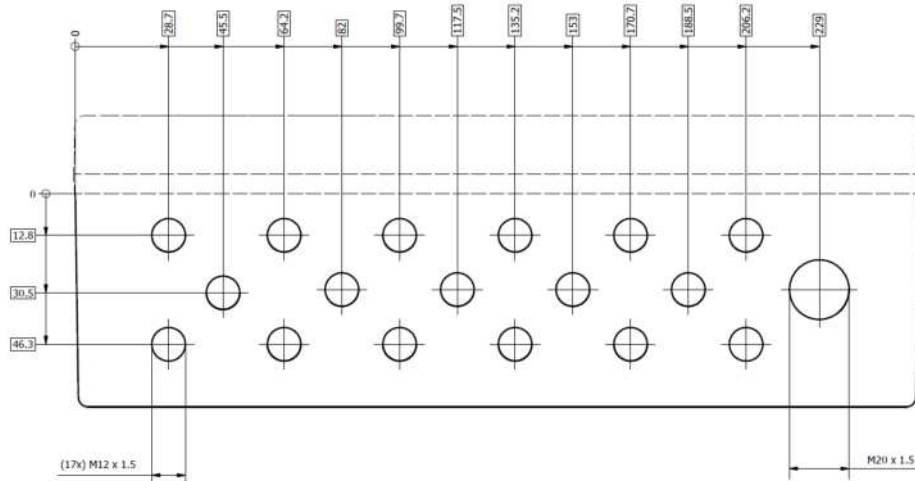

Figure 6 IMx-Rail enclosure pre-drilling – main long wall, 18 positions

The main wall gland area is for the majority of the user wiring (sensors etc.).

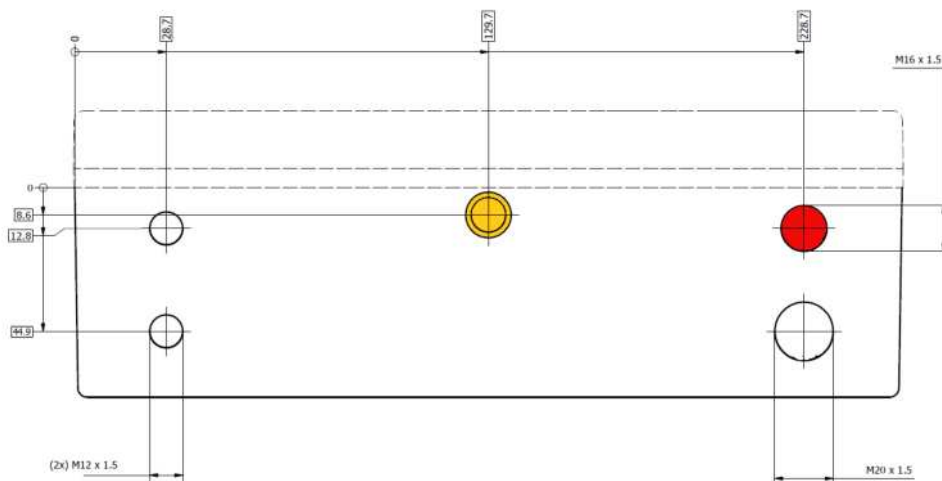

Figure 7 IMx-Rail enclosure pre-drilling – back long wall, 3 positions (1 connector in red)

The back-wall has three cable entries and the input power connector. This wall of the enclosure is also fitted with a screw-in membrane vent located centrally but towards the lid (that position is coloured orange in [Figure 7](#)).

On the short wall (power connector end), [Figure 8](#), there is one M32 opening that acts as a port for access to the IMx-16Plus SIM card slot.

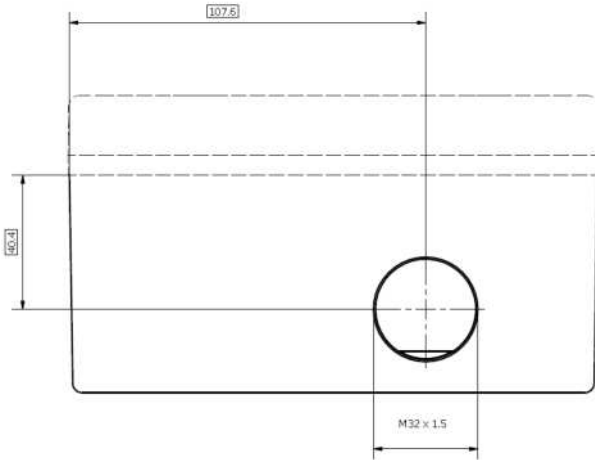

Figure 8 IMx-Rail enclosure pre-drilling – short wall, one access hole

3.6 GPS module mechanical drawings

The GPS module, CMON 4139, is connected to the IMx-Rail via a 5-m integral cable and should be fitted externally to the enclosure in a location that allows satellite tracking. An M12 cable gland is included.

The overall dimensions and fixing centres are shown in [Figure 9](#), below.

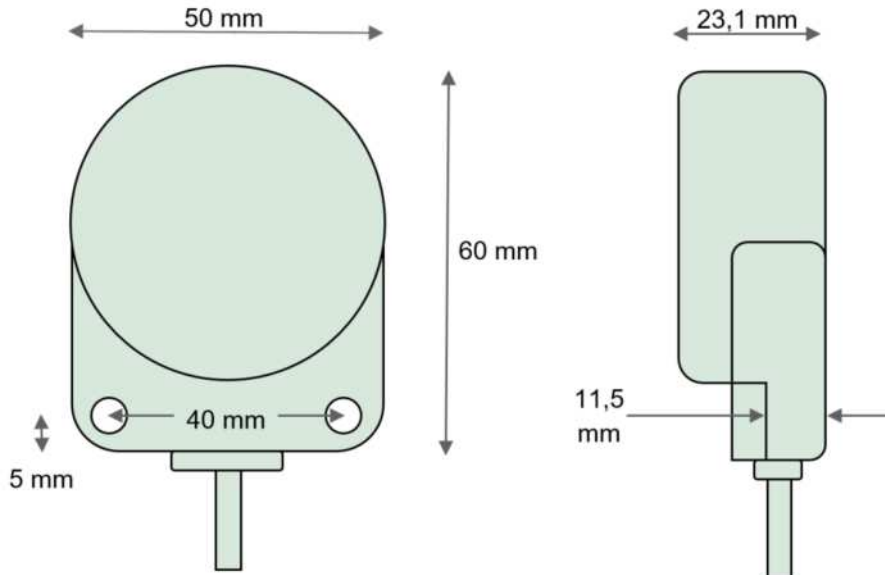

Figure 9 GPS module dimensions

The GPS module is designed to be fitted to a flat mounting surface and has two clearance holes for M5 fixings, 40 mm pitch, which straddle the cable exit.

4 Electrical waste



Electrical waste and electrical equipment should be recycled as specified by the WEEE-directive and not be placed in the general refuse. Product should be sent to an approved recycling centre for safe recycling, recovery, reuse or sent to SKF Sverige AB for proper recycling.

SKF Sverige AB
Aurorum 30
977 75 Luleå
Sweden

Appendix A Limited Warranty

SKF – Limited Warranty