

Modulating damper actuator for adjusting dampers in technical building installations

- Air damper size up to approx. 0.4 m<sup>2</sup>
- Nominal torque 2 Nm
- Nominal voltage AC/DC 24 V
- Control Modulating DC (0)2...10 V
- Position feedback DC 2...10 V
- With connecting terminals

**Technical data**

|                           |   |  |
|---------------------------|---|--|
| <b>Electrical data</b>    | Nominal voltage   | AC/DC 24 V   |
|                           | Nominal voltage frequency   | 50/60 Hz   |
|                           | Nominal voltage range   | AC 19.2...28.8 V / DC 19.2...28.8 V  |
|                           | Power consumption in operation  | 1 W  |
|                           | Power consumption in rest position                                      | 0.5 W  |
|                           | Power consumption for wire sizing                                       | 1.5 VA   |
|                           | Connection supply / control   | Terminals 1.5 mm <sup>2</sup> Cu wire or 1.0 mm <sup>2</sup> Cu strands (4-wire) |
|                           | Parallel operation  | Yes (note the performance data)  |
| <b>Functional data</b>    | Torque motor  | Min. 2 Nm  |
|                           | Positioning signal Y  | DC 0...10 V  |
|                           | Positioning signal Y note   | Input impedance 100 kΩ   |
|                           | Operating range Y   | DC 2...10 V  |
|                           | Position feedback U   | DC 2...10 V  |
|                           | Position feedback U note  | Max. 1 mA  |
|                           | Position accuracy   | ±5%  |
|                           | Direction of motion motor   | ccw rotation   |
|                           | Direction of motion note  | Y = 0 V: left end stop, position 0   |
|                           | Manual override   | with magnet  |
|                           | Angle of rotation   | 95°, fixed setting   |
|                           | Running time motor  | 75 s / 90°   |
|                           | Sound power level motor   | 35 dB(A)   |
| Spindle driver            | Universal spindle clamp 6...12.7 mm                                     |  |
| Position indication       | Mechanically, pluggable (with integrated magnet for gear disengagement) |  |
| <b>Safety</b>             | Protection class IEC/EN   | III Safety extra-low voltage   |
|                           | Protection class UL   | UL Class 2 Supply  |
|                           | Degree of protection IEC/EN   | IP20   |
|                           | Degree of protection NEMA/UL  | NEMA 1, UL Enclosure Type 1  |
|                           | EMC   | CE according to 2004/108/EC  |
|                           | Certification IEC/EN  | IEC/EN 60730-1 and IEC/EN 60730-2-14   |
|                           | Certification UL  | cULus according to UL 60730-1A, UL 60730-2-14 and CAN/CSA E60730-1:02            |
|                           | Mode of operation   | Type 1   |
|                           | Rated impulse voltage supply / control                                  | 0.8 kV   |
|                           | Control pollution degree  | 2  |
|                           | Ambient temperature   | -30...50 °C  |
| Non-operating temperature | -40...80 °C   |  |
| Ambient humidity          | 95% r.h., non-condensing  |  |
| Maintenance               | Maintenance-free  |  |
| <b>Weight</b>             | Weight  | 0.21 kg  |

**Safety notes**

- The device must not be used outside the specified field of application, especially not in aircraft or in any other airborne means of transport.

## Safety notes

- Outdoor application: only possible in case that no (sea)water, snow, ice, insolation or aggressive gases interfere directly with the actuator and that is ensured that the ambient conditions remain at any time within the thresholds according to the data sheet.
- Only authorised specialists may carry out installation. All applicable legal or institutional installation regulations must be complied during installation.
- The mechanical end stops for limiting the angle of rotation may only be removed for adjustment. They must always be mounted during operation.
- The device may only be opened at the manufacturer's site. It does not contain any parts that can be replaced or repaired by the user.
- To calculate the torque required, the specifications supplied by the damper manufacturers concerning the cross-section, the design, the installation site and the ventilation conditions must be observed.
- The device contains electrical and electronic components and must not be disposed of as household refuse. All locally valid regulations and requirements must be observed.

## Product features

|                                     |  |
|-------------------------------------|--|
| <b>Mode of operation</b>            | The actuator is connected with a standard modulating signal of DC 0...10V and drives to the position defined by the positioning signal. Measuring voltage U serves for the electrical display of the damper position 0...100% and as slave control signal for other actuators.   |
| <b>Simple direct mounting</b>       | The actuator is mounted directly on the damper spindle ( $\varnothing$ 6...12.7 mm) with an universal spindle clamp and then secured with the anti-rotation device supplied, to prevent it from rotating.  |
| <b>Manual override</b>              | Manual override with magnet possible (the gear is disengaged as long as the magnet adheres to the magnet symbol). The magnet for gear disengagement is integrated in the position indication.  |
| <b>High functional reliability</b>  | The actuator is overload protected, requires no limit switches and automatically stops when the end stop is reached.   |
| <b>Adjustable angle of rotation</b> | Adjustable angle of rotation with mechanical end stops.  |
| <b>Hidden synchronisation</b>       | If the actuator drives to the lower end stop during ongoing operation, then it performs a synchronisation of the positioning signal at DC 2 V. This ensures that the signal range also corresponds to the effective functional range in ongoing operation. The bottom end stop is actively approached as soon as the positioning signal is < DC 2.1 V. The actuator drives to the new specified position as soon as the positioning signal is once again > DC 2.3 V. |

## Accessories

|                               | Description                 | Type   |
|-------------------------------|-----------------------------|--------|
| <b>Mechanical accessories</b> | Anti-rotation clip for CM.. | Z-ARCM |
|                               | Magnet disengagement        | Z-MA   |
|                               | Position indicator CM..     | Z-PICM |

Electrical installation



Notes

- Connection via safety isolating transformer.
- Parallel connection of other actuators possible. Observe the performance data.

Wiring diagrams

AC/DC 24 V, modulating

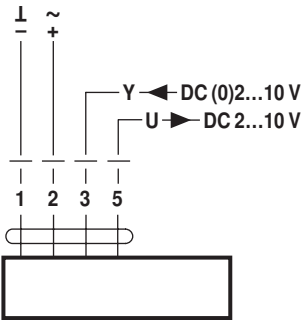

Dimensions [mm]

Spindle length

|  |         |
|--|---------|
|  | Min. 32 |
|  | -       |

Dimensional drawings

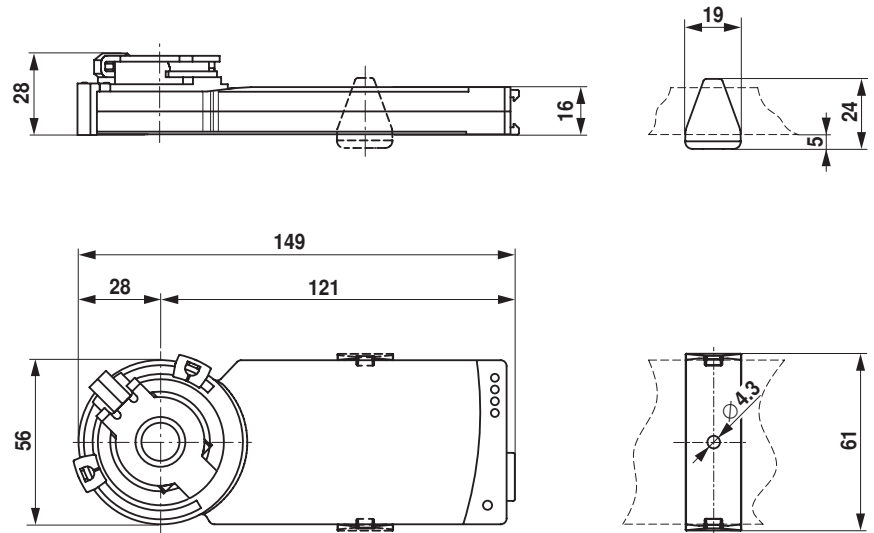

Clamping range

|          |            |          |
|----------|------------|----------|
|          |            |          |
| 6...12.7 | 6 / 8 / 10 | 6...12.7 |