



Professional wireless communication system solution supplier

# DP770

## SERVICE MANUAL



# Contents

<b>1. General Introduction.....</b>	<b>3</b>
1.1. Scope .....	3
1.2. Safety Precaution.....	3
<b>2. External View and Functional Keys .....</b>	<b>4</b>
2.1. External View and Functional Keys .....	4
2.2. LED Indicator .....	5
<b>3. Circuit Description.....</b>	<b>6</b>
3.1. RF Section.....	6
3.1.1. Transmitter Circuit.....	6
3.1.2. Receiver Circuit .....	8
3.1.3. Frequency Generation Unit .....	9
3.1.4. GPS Circuit .....	10
3.2. Baseband Section .....	11
3.2.1. Power Section.....	11
3.2.2. Audio Section.....	11
<b>4. Function Instruction and Parameters Setting .....</b>	<b>13</b>
4.1. General Functions.....	13
4.2. Parameters Setting .....	14
<b>5. Assembly and Disassembly .....</b>	<b>17</b>
5.1. Attaching and Detaching the Battery.....	17
5.2. Attaching and Detaching the Antenna.....	18
5.3. Attaching and Detaching the Belt Clip.....	19
5.4. Detaching the Chassis.....	19
5.5. Removing the PCB board from the Chassis .....	20
5.6. Detaching the Keypad Board from the Case.....	20
5.7. Exploded View .....	22
<b>6. Tune Mode .....</b>	<b>25</b>
6.1. Required parts in adjustment.....	25
6.2. Adjusting and checking method .....	25

6.2.1. Frequency description .....	25
6.2.2. Adjustment Equipments.....	26
6.2.3. Adjustment instruction of TX.....	26
6.2.4. Receiver section adjustment instruction.....	28
6.2.5. GPS Performance Test Instruction .....	30
<b>7. Main Specifications .....</b>	<b>31</b>
<b>8. Repairing and Testing Equipments.....</b>	<b>33</b>
<b>9. Basic Troubleshooting .....</b>	<b>34</b>
<b>Appendix 1 Material List( Electrics Parts) 400-470MHz.....</b>	<b>36</b>
<b>Appendix 2 Material List( Electrics Parts) 136-174MHz.....</b>	<b>54</b>
<b>Appendix 3 Material List (Structural Section) .....</b>	<b>66</b>
<b>Appendix Figure 1 DP770 UHF Main Board Top Side PCB View.....</b>	<b>69</b>
<b>Appendix Figure 2 DP770 UHF Main Board Bottom Side PCB View .....</b>	<b>70</b>
<b>Appendix Figure 3 DP770 UHF Keypad Top Side PCB View .....</b>	<b>71</b>
<b>Appendix Figure 4 DP770 UHF Keypad Bottom Side PCB View .....</b>	<b>72</b>
<b>Appendix Figure 5 DP770 UHF Main Board Schematic Diagram.....</b>	<b>73</b>
<b>Appendix Figure 6 DP770 UHF Keypad Schematic Diagram.....</b>	<b>85</b>
<b>Appendix Figure 7 DP770 VHF Main Board Top Side PCB View.....</b>	<b>86</b>
<b>Appendix Figure 8 DP770 VHF Main Board Bottom Side PCB View .....</b>	<b>87</b>
<b>Appendix Figure 9 DP770 VHF Keypad Top Side PCB View .....</b>	<b>88</b>
<b>Appendix Figure 10 DP770 VHF Keypad Bottom Side PCB View .....</b>	<b>89</b>
<b>Appendix Figure 11 DP770 VHF Main Board Schematic Diagram .....</b>	<b>90</b>
<b>Appendix Figure 12 DP770 VHF Keypad Schematic Diagram.....</b>	<b>102</b>

# 1. General Introduction

## 1.1. Scope

This manual is used for maintenance and repairing of the DP770 digital handheld radio, and intended to be used by experienced technicians and trained engineers. Changes may occur with the technology development. To require latest technology development information, please contact our company or the local dealer.

Before any repairing, please read this manual carefully.

## 1.2. Safety Precaution

### Electromagnetic Radiation Energy of Radio

Radios will generate and radiate electromagnetic energy, and Kirisun Radios' electromagnetic radiation meets the demand of domestic and international standards. To ensure optimum efficiency of the radio and reduce electromagnetic radiation, when using the radio, it should be perpendicular to the ground. Keep your mouth 2-5cm away from the microphone.

### Electromagnetic Interference

To avoid interference, please turn off the radio in the site which specifically forbids using radio, e.g. hospital, airport, health center and etc.

### Explosive harmful gases

In the place with explosive harmful gases, such as the lower deck of a hull, fuel or chemical storage, transportation facilities, places that contain chemicals or dust particles or metal powder in the atmosphere, radio should be shut down.

When getting close to the blast zone and detonator electric, radio should be turn off.

Charging or replacing battery is not allowed in the place with potential explosive gases.

### Antenna Damage

Do not use the radio when the antenna is broken, which will cause a mild burn to your skin.

### Replacing Spare Parts

Please try not to replace the spare parts which are not contained in the spare part list.

## 2. External View and Functional Keys

### 2.1. External View and Functional Keys

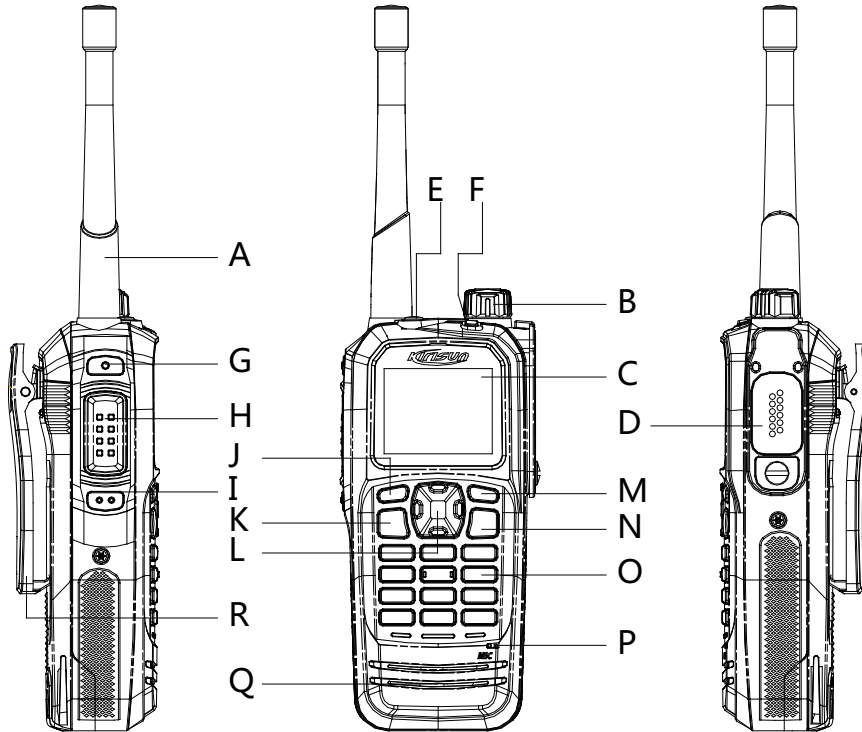

No.	Part Name	No	Part Name
A	Antenna	B	Volume/Channel Knob Rotate the knob to adjust the volume.Short press the key, the feature of the knob switches from adjusting the volume to changing the channel.
C	LCD Display 160*128, 65K colors, 1.8 TFT LCD.	D	Universal Connector for Accessories Connect USB programming cable, earphone or some other accessories.
E	Top Key (TK) Programmable, default: short press to enable emergency alarm, long press to exit emergency alarm.	F	LED Indicator
G	Side Key 1 (SK1) Programmable, default: none.	H	PTT Key
I	Side Key 2 (SK2)	J	Left Key

	Programmable, default: none.		Press the key to select the items shown at the bottom left of the screen.
K	Dial Key Press the key to send data or text messages.	L	4-way Navigation Key
M	Right Key Press the key to select the items shown at the bottom right of the screen.	N	ON/OFF/Hookoff Key Return to the standby screen. Long press the key to turn on/off the radio.
O	Numeric keypad	P	MIC
Q	Speaker		

## 2.2.LED Indicator

- Red LED glows: Radio is transmitting.
- Green LED glows: Radio is receiving (voice, short message, or data) or there is an activity on the channel.
- Orange LED glows: This means the call hang time period. That is, you can press PTT to talk while the orange LED glows
- Orange LED flashes: Radio is in emergency status; or there is a missed call / incoming call alert; or the radio is scanning.
- Red LED flashes: Radio is receiving emergency alarm or "power on check" failed.

# 3. Circuit Description

## 3.1. RF Section

Figure 3-1 RF Schematic Diagram

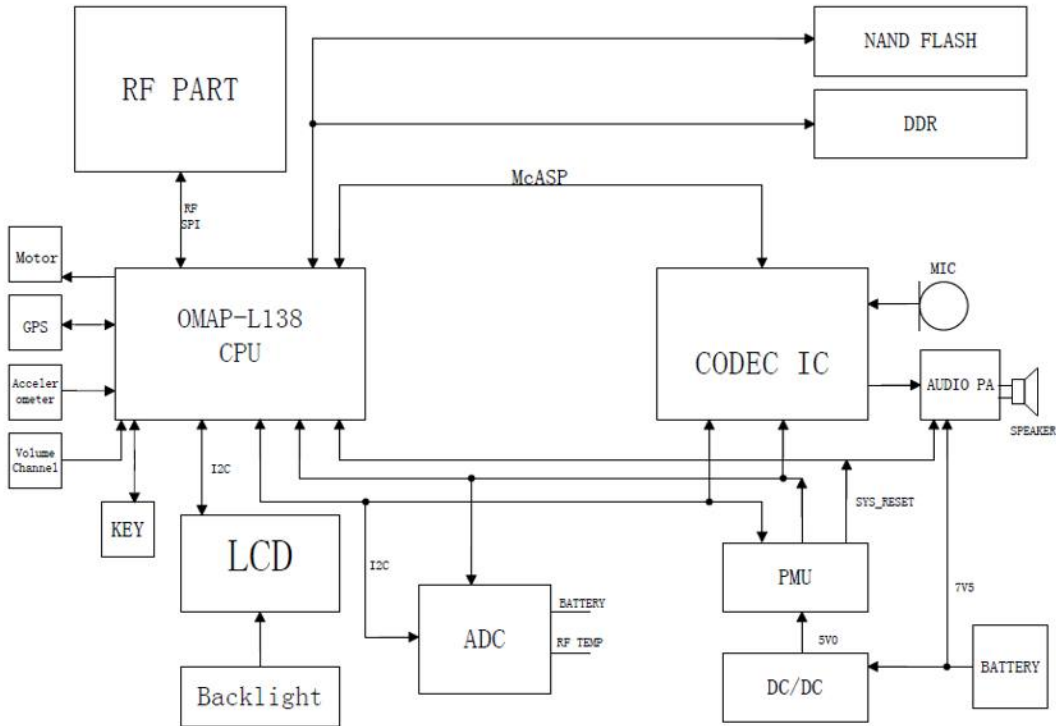

### 3.1.1. Transmitter Circuit

Figure 3-2 Transmitter Circuit Diagram

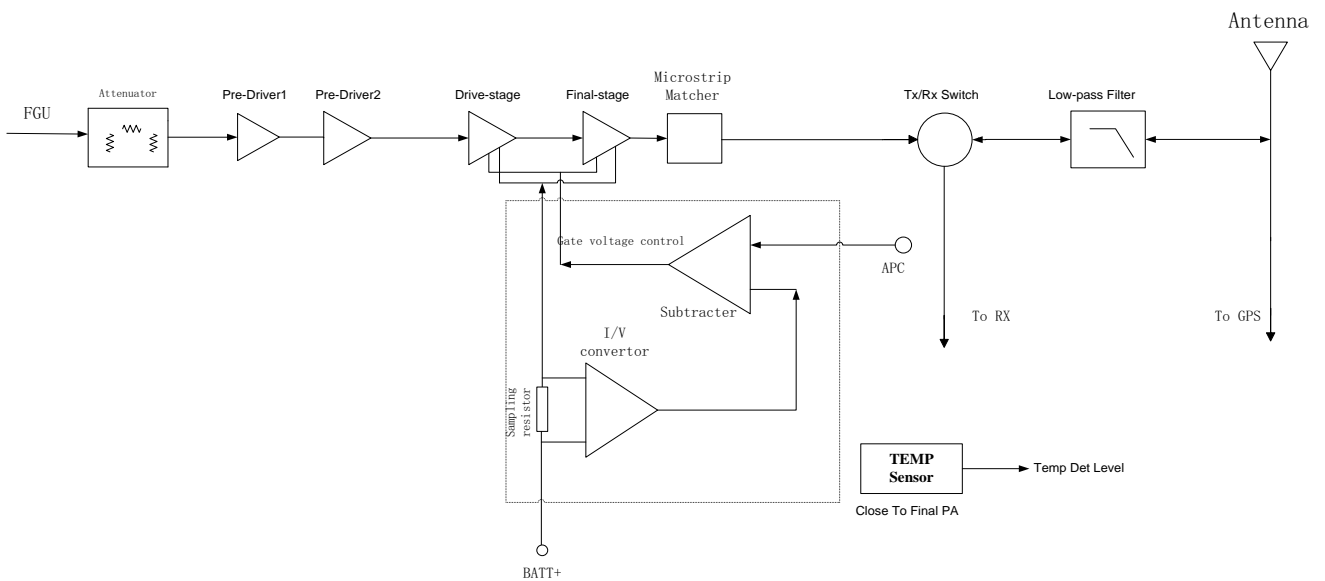

The transmitter circuit includes three parts:

- **Transmitter Power Amplifier**

The carrier signal generated by the TX VCO is modulated and amplified, and feeds to the transmitter circuit via the following steps.

Step1: The signal passes a  $\Pi$ -type attenuator, realizing segregative isolation between RF power amplifier circuit and TX VCO.

Step2: The signal are pre-amplified by a pre-driver amplifier (UHF: Q301, VHF: Q72), providing further segregative isolation between itself and the next level amplifier.

Step3: The signal goes to the next pre-amplifier and drive amplifier (RD01) to obtain further amplification, guarantying to provide enough driver power signal to the final-stage amplifier (RD07) and obtain the final power amplification..

Step4: After amplified by multiple amplifiers, the transmitter signal is processed by a microstrip line to complete output impedance matching at the output of final-stage amplifier, to reduce the output loss caused by impedance mismatch.

Step 5: The transmitter signal goes through the RX/TX switch and enters to the low-pass filter.

- **Low-pass Filter Circuit of suppressing the harmonics**

The low-pass filter is high-grade low-pass filter composed of lumped-parameter inductors and capacitors. By this filter, the spurious signal within the stop band can be attenuated as much as possible while the in-band ripple is within the required range.

- **Auto Power Control Circuit (APC includes temperature detection circuit)**

In the auto power control and temperature detection circuit, the drain current from the driver amplifier and final-stage amplifier is converted to voltage via the sampling resistor and subtraction circuit which is composed of the first operational amplifier.

This voltage is compared with the APC control voltage of output by DAC at the second operational amplifier. Then the error voltage controls TX power by controlling the bias voltage at the gate of amplifier (including the driver amplifier and the final-stage amplifier. The temperature sensor IC detects the surface temperature of the final-stage amplifier, and converts it to DC voltage. Then the DC voltage is compared with the voltage corresponding to the protection temperature (generally 80% of the extreme temperature) of the amplifier. If the temperature is too high, the bias voltage of the amplifier will be reduced until the surface temperature falls below the protection temperature.



### 3.1.2. Receiver Circuit

Figure 3-3 Receiver Circuit Diagram

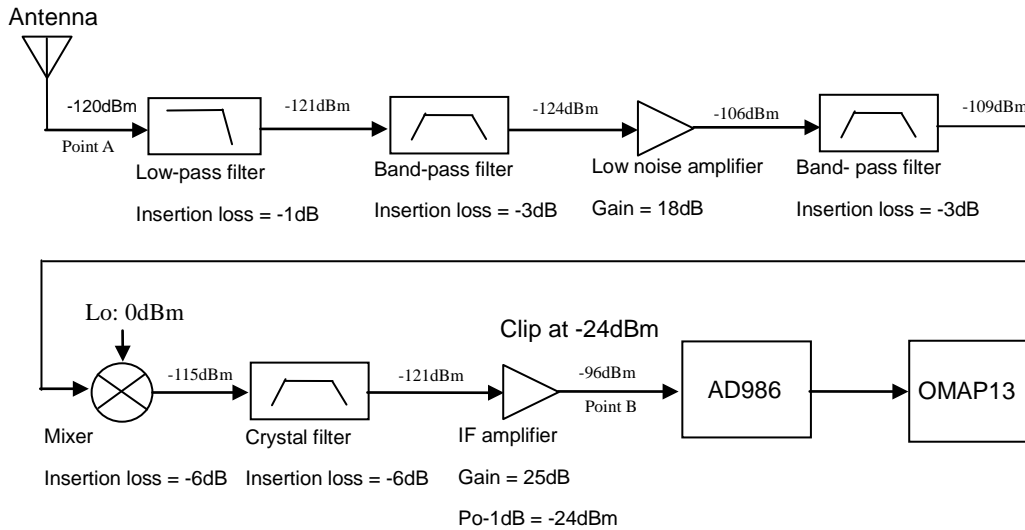

The receiver circuit mainly comprises RF band-pass filter, low-noise amplifier, mixer, IF filter, IF amplifier and IF processor.

- Receiver Front-end**

The HF signal from the low-pass filter passes through the electrically tunable band-pass filter controlled via APC/TV1 level, to remove out-of-band interference signal and to send wanted band-pass signal to the low-noise amplifier (UHF:Q205,VHF:Q62). The amplified signal goes to a band-pass filter controlled via TFV level to remove out-of-band interference signal generated during amplification, and to send wanted HF signal to the mixer (UHF:Z201,VHF:Z10).

Meanwhile, the first local oscillator signal generated by VCO passes through the low-pass filter and also goes to the mixer (UHF: Z201, VHF: Z10). In the mixer, the wanted signal and the first local oscillator are mixed to generate the first IF signal (UHF: 73.35MHz, VHF: 51.65MHz). The signal passes a frequency selective network composed of LC, to suppress carrier other than the first IF signal, and to increase the isolation between the mixer and the IF filter. After that, the first IF signal is processed by the crystal filter (UHF: Z202, VHF: Z11) and is sent to the two-stage IF amplifier circuit composed of 2SC5006 for amplification. Then the amplified signal goes to the IF processor AD9864 (UHF: U201, VHF: U91) for processing.

- Receiver Back-end**

Figure 3-4 IF Processor Diagram

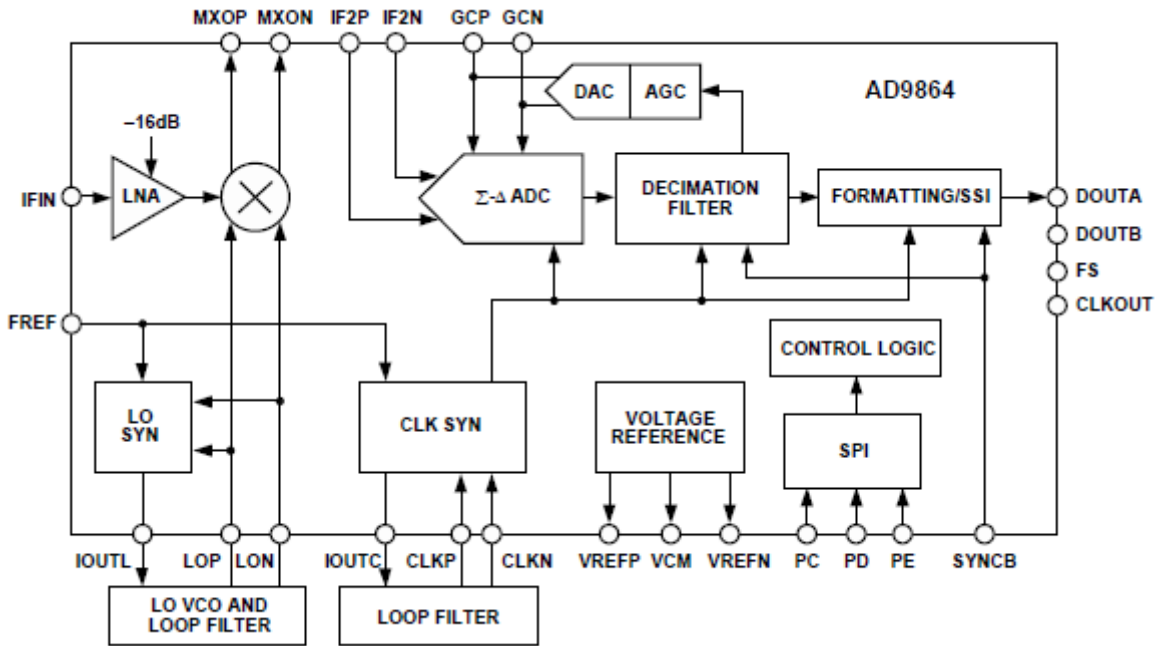

The first IF signal (73.35MHz) output by the IF amplifier goes into AD9864 (UHF: U201, VHF: U91) via Pin 47 and completes the second mixer, where the signal is converted to the second IF signal (2.25 MHz). The second IF signal is converted to digital signal via ADC sampling, and output via the SSI interface. Finally, the digital signal is sent to DSP (OMAP138) for demodulation.

AD9864 employs reference frequency of 12.8MHz. The second local oscillator is composed of an external oscillator, a varactor and some other components, to provide the (UHF: 71.1MHZ, VHF: 49.4MHz) 71.1MHz LO signal. The 18MHz clock input frequency of AD9864 is generated by the LC resonance loop.

### 3.1.3. Frequency Generation Unit

Figure 3-5 Frequency Generation Circuit Diagram

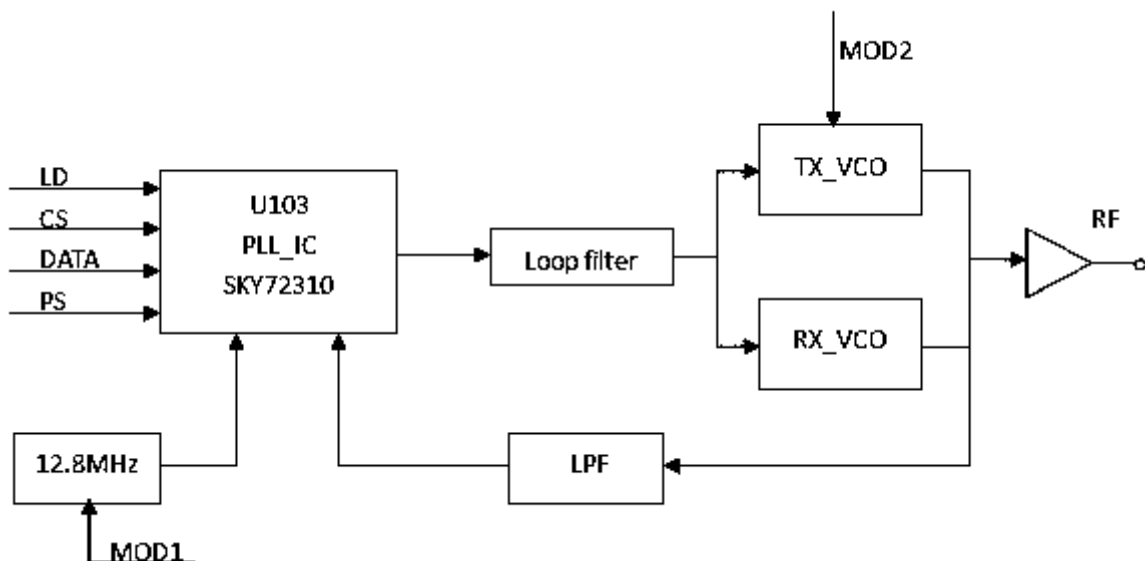

The frequency generation circuit is composed of VCO and PLL. It is the core module of the whole TX-RX system. This circuit provides accurate carrier frequency during transmission; and provides stable local oscillator signal during reception. It has a direct influence on the performance of the system.

- **Working Principle of PLL**

The 12.8MHz frequency generated by the reference crystal oscillator goes to PLL for division, generating the reference frequency (i.e step frequency  $f_1$ ). The frequency generated by VCO is filtered harmonic via LPF and generates another frequency ( $f_2$ ) through the frequency divider in PLL. Then frequencies  $f_1$  and  $f_2$  are compared in the phase detector (PD), to generate continuous pulse current. The pulse current goes to the loop filter for RC integration and is then converted to CV voltage. Then the CV voltage is sent to the varactor of VCO. It adjusts the output frequency of VCO directly until the CV voltage becomes constant. Then the PLL is locked, and the stable frequency output by VCO goes to the TX-RX channel after passing through two buffer amplifiers.

- **Working principle of VCO**

Voltage controlled oscillator applies oscillation mode of three-point capacitance, and gains different output frequency through changing controlled voltage (CV) of varactor. Rx VCO is composed of oscillating circuit and Q24/Q29 and provides local oscillation signal. Tx VCO is composed of oscillating circuit and Q27/Q28 and provides carrier of Tx signal.

Working principle employs colpitts oscillator circuit (the RX oscillator circuit is composed of D102, D103, D106, D107 and L112 (VHF:D32, D33, D36, D34 and L23); the TX oscillator circuit is composed of D108, D109, D110, D101 and L117 (VHF:D38, D39, D40, D41 and L31). It obtains different output frequencies by changing control voltage of varactor (i.e.CV voltage).RX VCO is composed of oscillator loop and Q104 (VHF:Q43), providing local oscillator signal. TX VCO is composed of oscillator loop and Q108 (VHF Q44) and provides carrier of TX signal.

- **Two-point Modulation**

To obtain higher modulation accuracy and lower 4FSK bit error, it employs two-point modulation technology in the TX mode. MOD1 and MOD2 send the modulation signal to the modulation end of VCO and the reference crystal oscillator of PLL respectively to modulate TX VCO and the reference crystal oscillator.

### 3.1.4. GPS Circuit

Figure 3-6 GPS Circuit Diagram

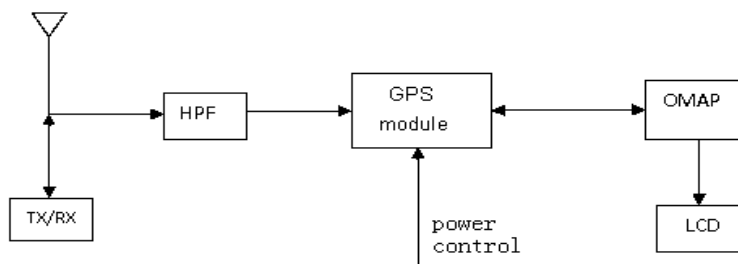

The GPS function is realized via REB-1315LPx (GPS module).The GPS module integrates a baseband processor, a LAN and a SAW. The GPS function is realized via the following steps:

Step1: The 1575.42MHz GPS signal is received by the antenna, and then goes to HPF to remove the in-band signals used for transmission and reception.

Step2: The signal goes to GPS module for amplification and filtering after frequency selection via filter. Then it will be sent to baseband section for calculation.

Step3: The calculated GPS position information is sent to OMAP for processing via the UART interface. Meanwhile, OMAP138 can send appropriate command information to the GPS module via the UART interface.

Step4: Finally, the OMAP sends the processed data information to the LCD.

## 3.2. Baseband Section

### 3.2.1. Power Section

Figure 3-7 Power Section Diagram

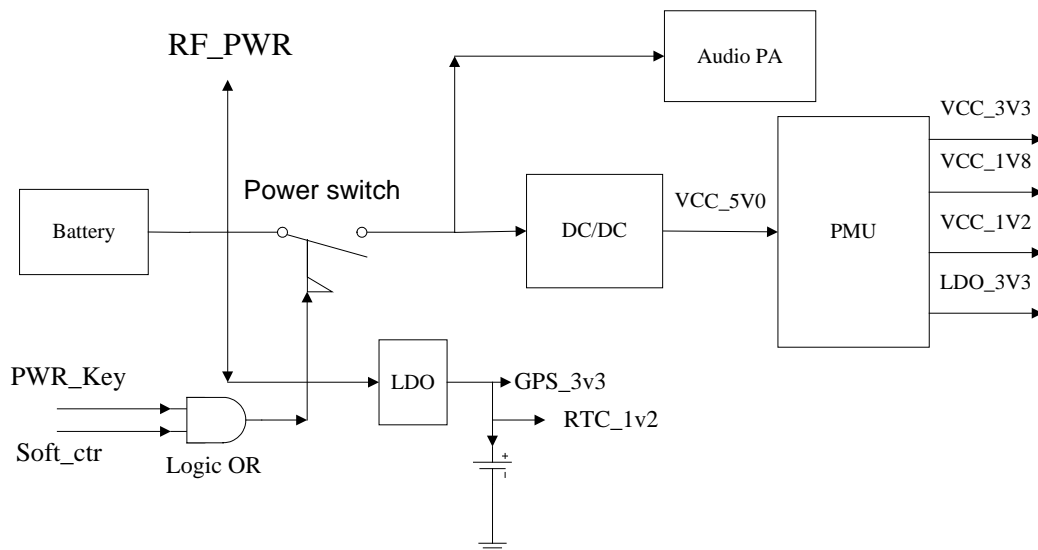

The radio adopts 7.4V li-ion battery as power supply. The baseband and RF circuit are supplied by independent power structure. The baseband power is composed of two stage conversion circuit. The first stage reduces the battery voltage to 5V by DC/DC, and the second stage converts the 5V voltage to power required voltage for the system by the power management.

Power On/Off: Power On/Off is implemented through a PMOS component. When the Power On/Off key is pressed, PWR\_Key signal becomes high level, and PMOS component becomes conducted. The system will begin initialization and set Soft\_ctr to be high level. Thus, the radio is powered up. During the power off process, when the system detects that the Power On/Off key is pressed, the system will begin executing the shut down operations, and finally set Soft\_ctr to be low level, which will shut down the PMOS component, thus the radio being powered off.

### 3.2.2. Audio Section

The audio module is mainly for audio input and output. It uses TLV320AIC14 as audio codec to convert and

process audio signal and digital signal. The audio amplifier TDA8547TS is used to amplify the analog audio signal.

DSP processes digital signal (i.e audio signal encoding/decoding, digital I/Q signal decoding, digital audio signal processing). The AD9864 converts and processes the RF IF, and sends un-demodulated serial digital signal to the DSP for processing. Then DAC5614 converts the digital signal output by DAS to analog signal.

Figure 3-8 Audio Section Diagram

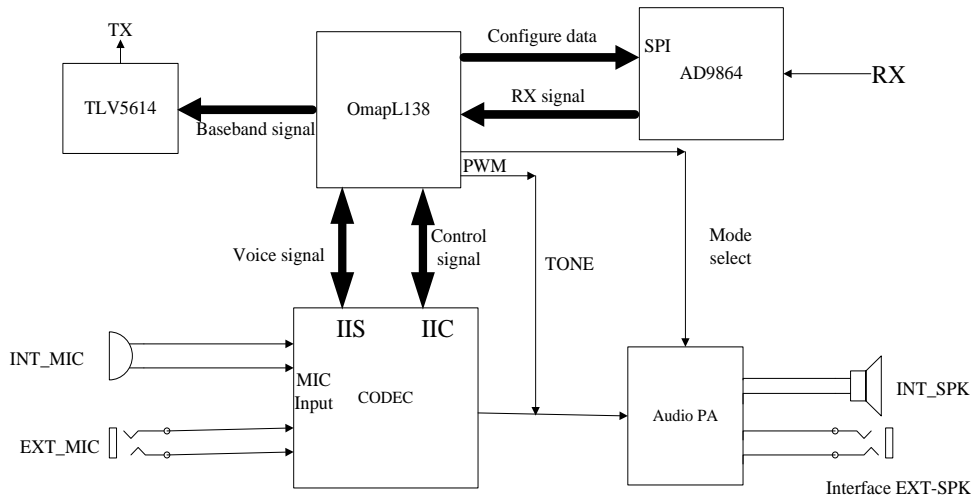

• **Diagram of Signal Flow**

The microphone converts the audio signal into electrical signal, which is amplified by PGA of the codec and then sent to ADC of the codec for sampling. After digital audio processing, the signal is output DSP for processing. Then the signal is sent to DAC (TLV5614), which converts the signal to modulation signal. After modulated and amplified in the RF module, the signal is sent out from the antenna.

The RF signal received by the RF module is converted to digital by ADC (AD9864), and is then sent to DSP for modulation and processing. Then the digital signal is sent to the digital audio processor of the codec for digital audio processing, and is then converted into analog audio signal by DAC of the codec. Finally the signal is amplified by the external audio amplifier (TDA8547TS) to drive the speaker.

• **System Peripheral Function Unit**

The system peripheral consists of analog/digital converter module, vocoder encryption module, TF card interface module, display module, key detection module and acceleration sensor module. These modules are used to achieve human-radio interaction, state detection, communication encryption and feature extension. The analog/digital converter is used for voice signal strength detection, power supply detection, temperature detection, so as to realize VOX, low battery warning and temperature control. The acceleration sensor is used to detect tilted state, realizing mandown function. The TF card module interface is used for communication encryption, to provide communicate security.

Figure 3-9 The Composing of System Basic Peripheral

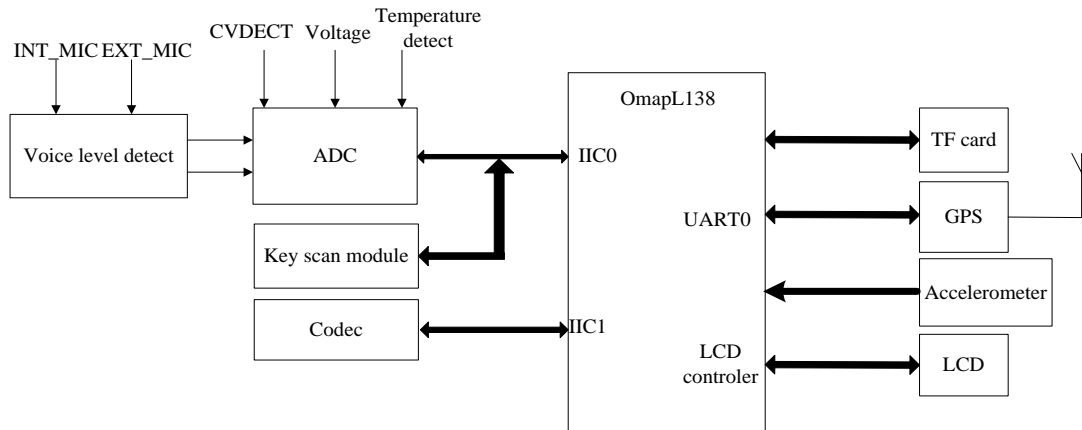

## 4. Function Instruction and Parameters Setting

### 4.1. General Functions

- Support P-Call, G-Call, A-Call in digital mode.
- Support P-Call, G-Call, A-Call in analog mode.
- Support Transmit Interrupt function in digital mode.
- Support Encryption of both voice and data.
- Support Short message, status message and GPS data information.
- Support Stun, Un-kill, Remote Monitor, Call Alert digital signaling.
- Support Self-defined Kill digital signaling.
- Support CTCSS/CDCSS in analog mode.
- Support MDC1200, 2 Tone, DTMF, 5Tone signaling system in analog mode.
- Support Emergency function.
- Support scan function of digital channel, analog channel and mixed digital and analog channel.
- Support the maximum of 1024 channels capacity.
- Support the maximum of 248 Zones and the maximum of 128 channels in every zone.
- Support the maximum of 512 contacts.
- Support graphic menu operation interface.
- Support LED, choices of alert tones and vibration indication.
- 12.5 kHz, 20 kHz or 25 kHz channel spaces can be chosen by PC software.
- Real-time display of signal strength.
- Support battery display and low battery alarm alert functions.

## 4.2. Parameters Setting

Radios have default parameters. While users can set parameters of frequency, channels, function of scanning or encryption, etc according your own requirements.

- **Parameters setting steps as follow:**

- Step 1. Install the right version of Kirisun CPSp.
- Step 2. Connect radio with computer by Kirisun programming cable.
- Step 3. Make sure radio's power is on.
- Step 4. Execute CPSp and start operation.

- **CPSp installation steps as follow:**

- Step 1. Double click the installation file; pop-up interface as Figure 4-1.

Figure 4-1

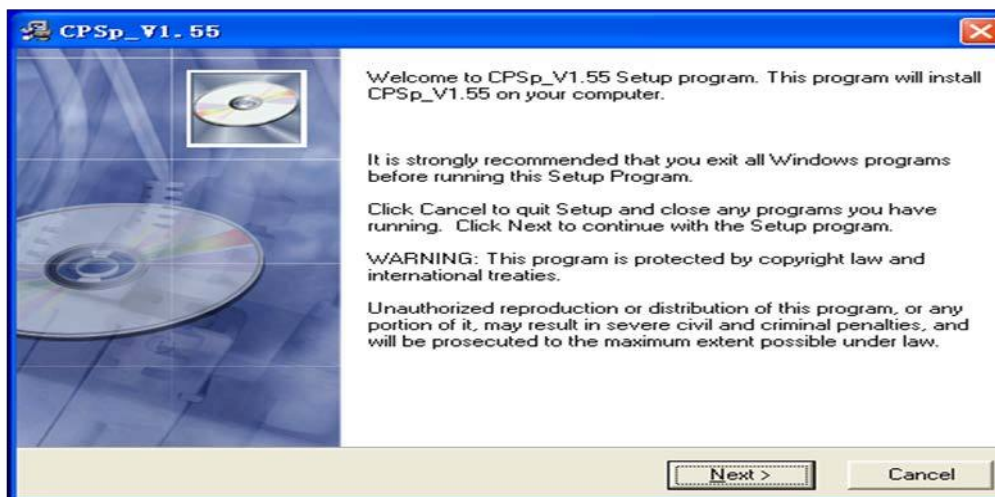

- Step 2. Click "Next" and enter into the next interface to choose the installation route.
- Step 3. In the interface shown in Figure 4-2, users can click "Browse" to choose the installation route, or use the default route, and click "Next" to enter the next interface to choose language.

Figure 4-2

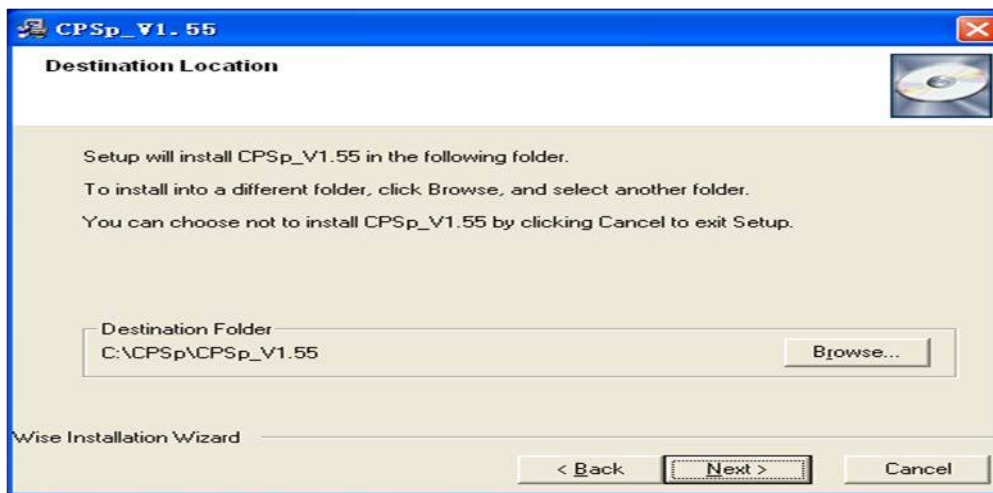

Step 4. Click "Next" to enter into installation information confirmation interface.

Figure 4-3



Step 5. Click "Next" to enter into the finished interface.

Figure 4-4



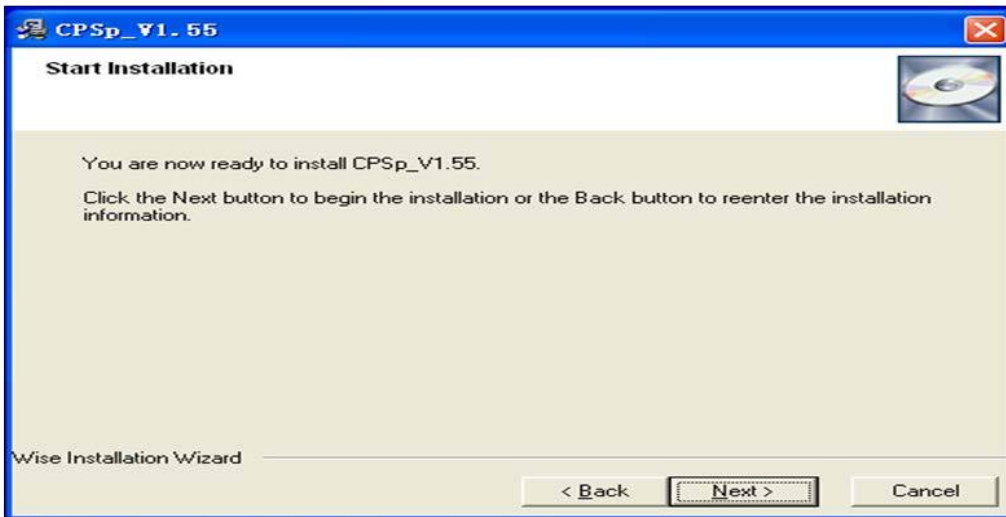

Step 6. Click "Finish" to finish installation.

Figure 4-5

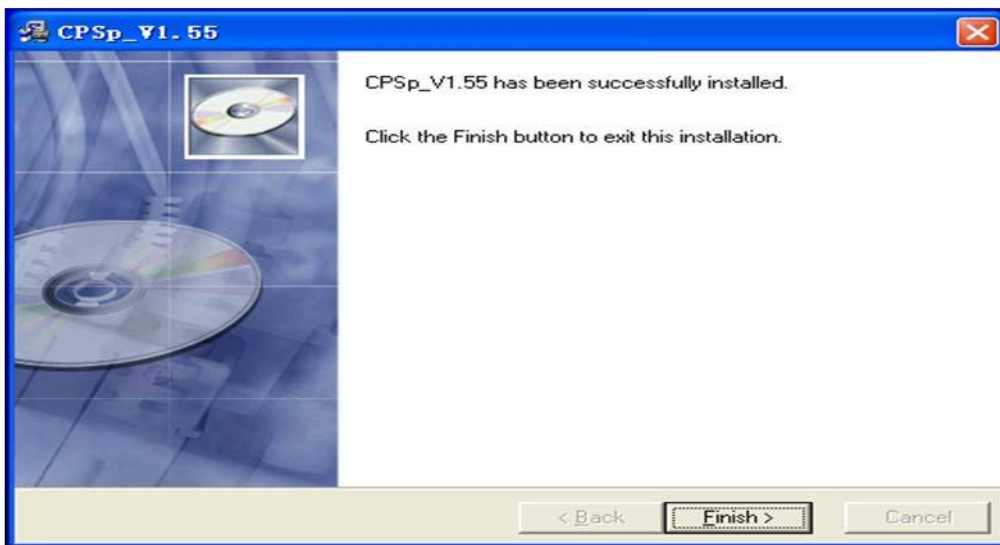

Step 7. After successful installation, double click the software, as shown in Figure 4-6

Figure 4-6

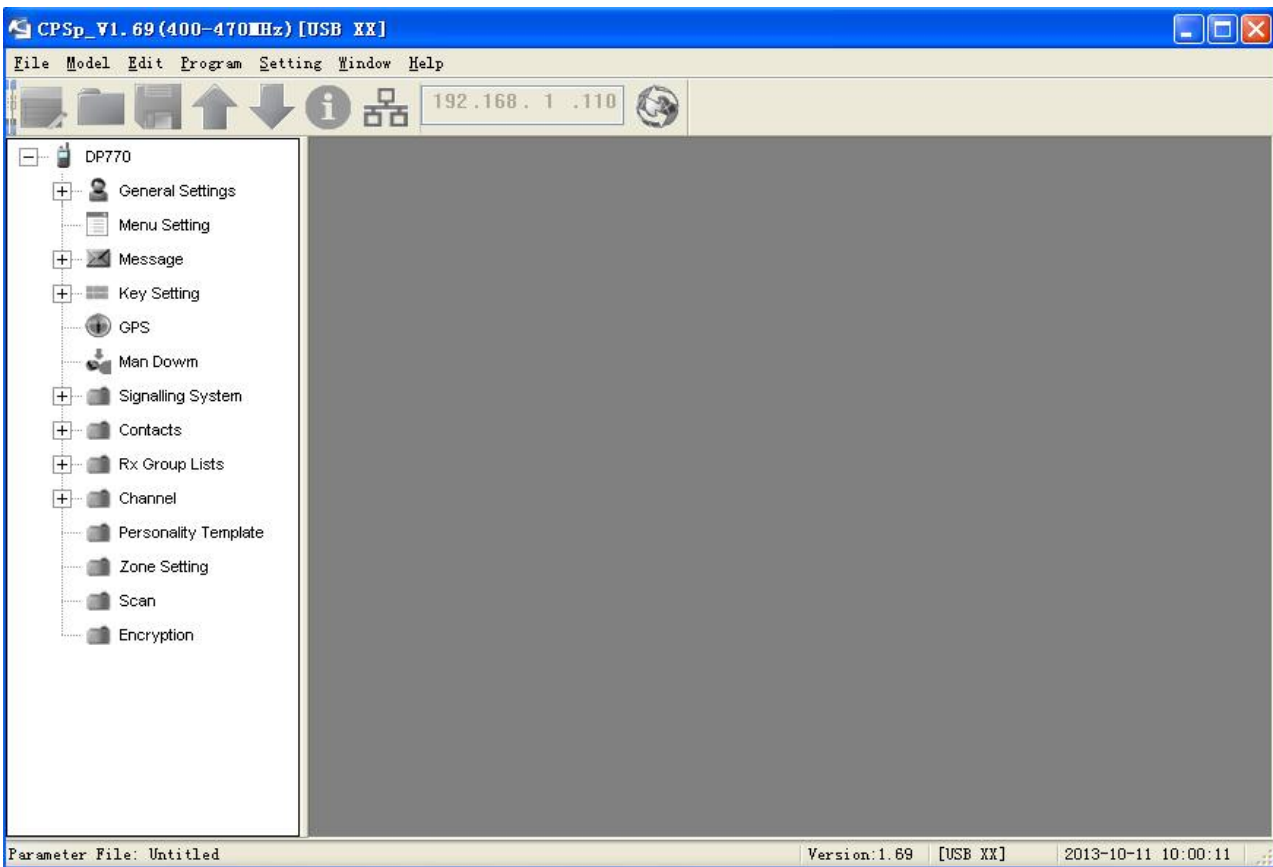

Users can read the radio's date, or revise the data and then write into the radio.

Please refer to the help file in the CPSp for the detailed operation instruction about Kirisun CPSp.

**Notes:**

Errors of parameter configuration may make certain functions cannot be used properly, in general, which can be solved by writing the correct parameters configuration.

Before parameter configuration modification, we strongly recommend backup the current parameters, make sure that the radio can restore after an error occurs.

## 5. Assembly and Disassembly

### 5.1. Attaching and Detaching the Battery

Attaching the battery as shown in figure 5-1.

Put the battery into radio's aluminum alloy bracket slot.

Push up until a click is heard.

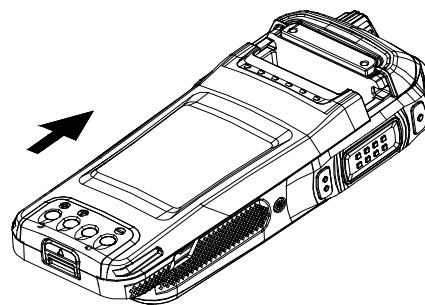

Figure 5-1

Detaching the battery as shown in Figure 5-2

Push up the battery buckle at the end of the battery.

Pull down to detach the battery.

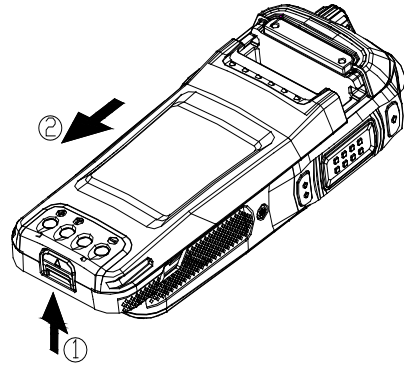

Figure 5-2

## 5.2. Attaching and Detaching the Antenna

As shown in Figure 5-3, put the antenna into radio's thread hole, and rotate clockwise to fasten it.

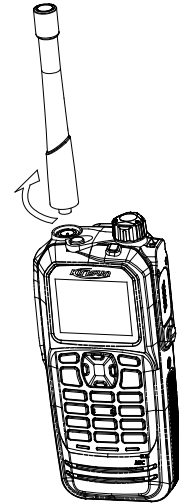

Figure 5-3

As shown in Figure 5-4, rotate counter-clockwise to detach.

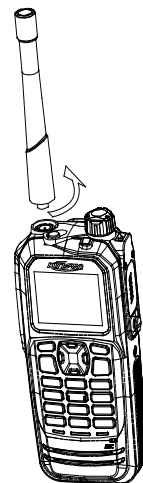

Figure 5-4

## 5.3. Attaching and Detaching the Belt Clip

As shown in Figure 5-5, align the screw holes on the belt clip, which is located on the back of the radio, and fasten them with the screwdriver.

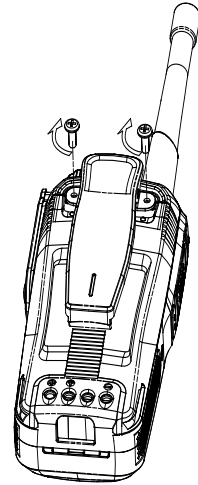

Figure 5-5

As shown in Figure 5-6, unfasten the screws to detach the belt clip.

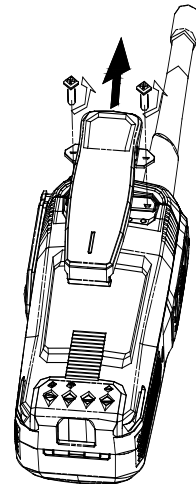

Figure 5-6

## 5.4. Detaching the Chassis

- Step 1. Detaching the belt clip (Figure 5.6);
- Step 2. Removing the antenna (Figure 5.4);
- Step 3. Removing the battery (Figure 5.2);
- Step 4. Removing the two screws on the bottom of the chassis. Remove the two screws on the side of shell, and remove the nut from antenna connector.

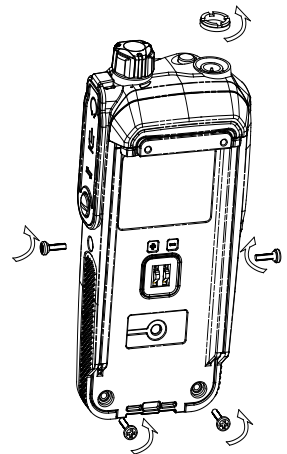

Figure 5-7

Step 5. Refer to Figure 5-8. Insert the flat-bladed screwdriver into the slot of Al alloy bracket; lift it so as to separate the Zinc alloy bracket from the chassis, and then push the Al alloy bracket away from the chassis, and take the soft flat cable away from the socket. Separate the speaker connecting cable by the soldering iron to.

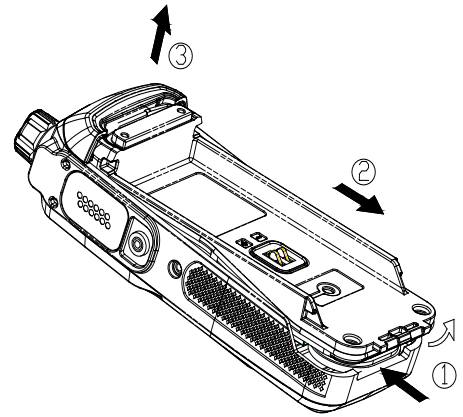

Figure 5-8

## 5.5. Removing the PCB board from the Chassis

Step 1. Remove the ten screws on the PCB board.

Step 2. Cut off the antenna connecting point by the soldering iron and then separate the PCB board from the chassis.

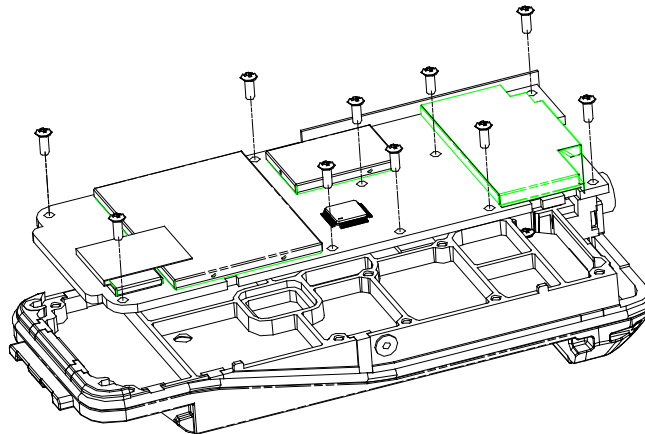

Figure 5-9

## 5.6. Detaching the Keypad Board from the Case

Step 1. Insert the flat-bladed screwdriver into the slot between the volume knob and case, lift the volume knob and take off it. Remove the volume knob nut by special tool in the clockwise direction. Separate the volume soft flat cable from the socket.

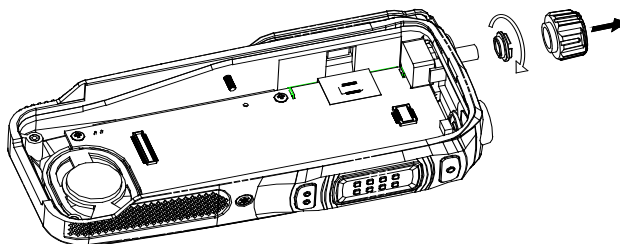

Figure 5-10

Step 2. Separate the speaker and MIC cable by soldering iron.

Step 3. Remove the four screws from keypad board and take off keypad PCB from case. (See Figure 5-11)

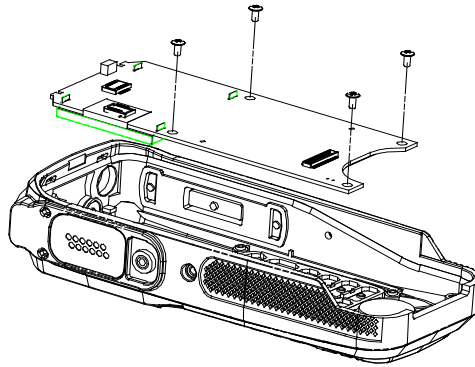
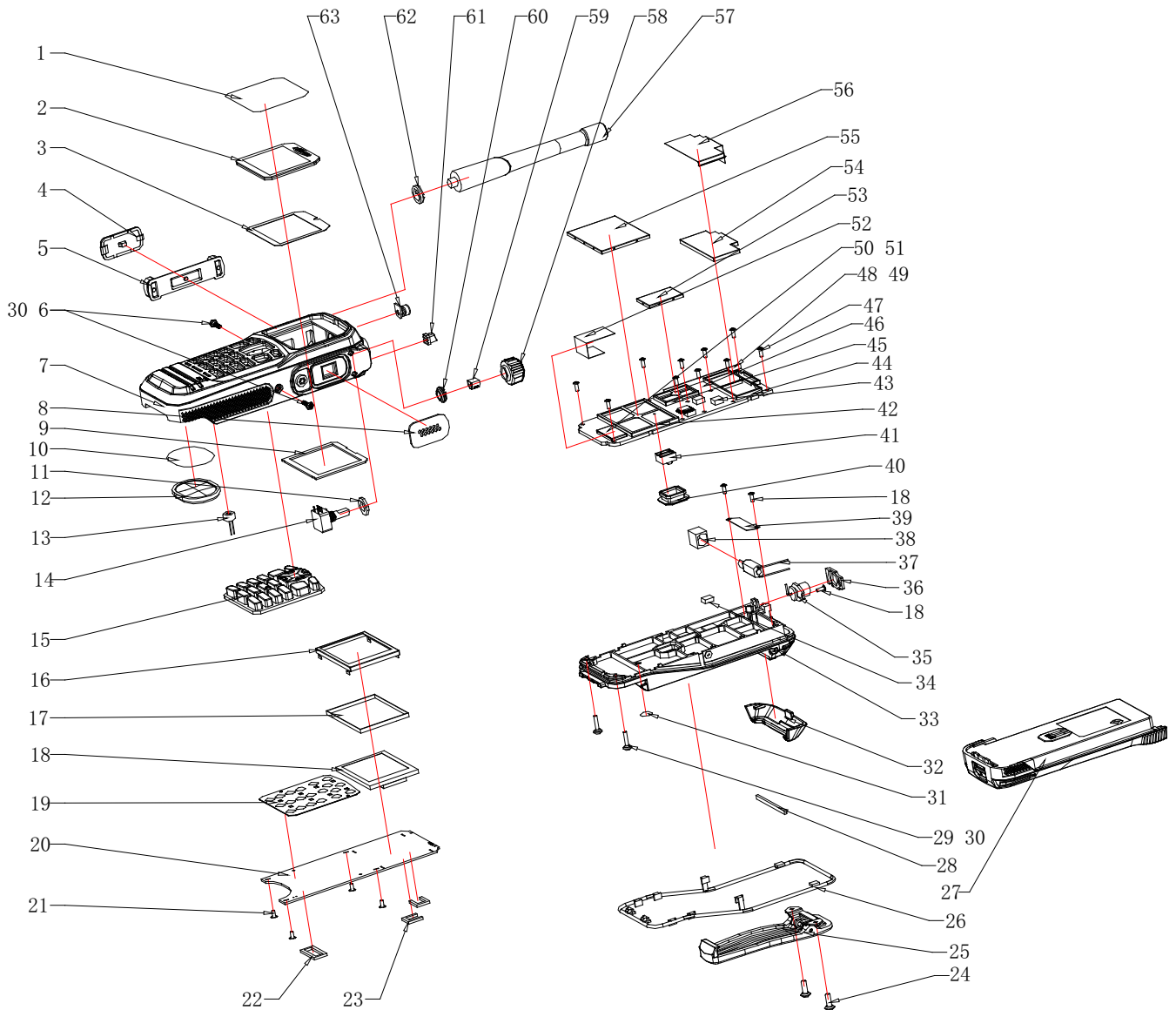

Figure 5-11

Step 4. After the detaching above, you can make the appropriate repairs and debug against fault conditions.

## 5.7.Exploded View



### Spare Parts List (Structure)

NO.	Part Number	Name, Specification	Quantity
1	7WFP-4002-01A	DP770lens protective film PET; transparent	1
2	7MHP-4002-02A-WC	DP770 LCD lens PC+PMMA, transparent	1
3	7GCJ-S4002-J	DP770 lens double sides adhesive tapeNITTO 57120B	1
4	7MHP-4002-04A-W9	DP770 PTT cover PC+ABS/TPU; black/PT2757C	1
5	7MHR-4002-10A-W6	DP770 Side silicone buttons silica gel; blue,PT654C	1
6	7SAF-020070M-SZYB-Z 1	2.0X7.0 iron hardened tooth machine screw; Zinc plating-black	2
7	7MHP-4002-01A-W0	DP770 front cover shell PC+ABS, texture, black	1
8	6SS1-4002-HL3C	Attachment plate strips nesting	1
9	7MHM-4002-01A-W9	DP770 LCD Sponge back rubber; black	1
10	7GCB-S4002-01A	DP770 Trumpet anti-dust mesh nylon; black	1

11	7MHR-4002-16A-W9	DP770 Knob waterproof pad silica gel; black	1
12	4SS7-3525-016-100A	DP770 speaker (waterproof) $\Phi=35\text{mm}$ , H=25mm, 16 $\Omega$ , 1W	1
13	4SM7-4002-A40	Waterproof microphone with cover $\Phi 7.0\text{mm}$ , height 2.8mm,	1
14	4SM7-4002-A40	Encoder switch RE11(Linjiwei)	1
15	7MHR-4002-09A-W9	DP770 The silicone number buttons; PT432C/ character with photopermeability	1
16	7MHS-4002-01A-W	DP770 LCD Cupronickel stents; Xianfeng Hardware	1
17	7MHC-4002-11A-W	DP770 display shielding cover 44.3*34.1*2.0MM, cupronickel	1
18	4PC7-4002H-A	LCD display ZYW-T18CP-20PJ-B	1
19	7MHS-4002-03A-W	Numeric key METAL DOME diameter 4.0; SUS301	1
20	6PM7-4002-HKG	DP770KEY-LCD PCB Four-layer board	1
21	7SMF-020040M-SZYB-N	M2*4 iron hardened tooth machine cross screw, Nylok	7
22	7GCM-180090015-J	DP770 main board double-sided adhesive foam black foam 18*9*1.5	1
23	7GCM-100090015-J	LCD Socket black foam double-sided adhesive foam10*9*1.5	2
24	7SMF-026060M-SZHT-B 1	M2.6*6 cross, machine ferrous hardened, Black zinc machine teeth	2
25	6SS3-BJ4026-A	KBJ-15 Belt Clip PC+ABS	1
26	7MHR-4002-11A-W9	DP770 main waterproof circle of silica gel; black	1
27	6SS3-DC7198-A	KB-77B battery	1
28	7MHM-4002-02-W	Aluminum chasis Poron , liner, Poron 36.5*2.5*1.0	1
29	7SAF-020110M-SZYB-Z 1	2.0X11.0 tooth machine cross screws 5.3 harden iron; zinc plating-black	2
30	7MHR-4002-19A-W9	DP770 Screw waterproof rubber ring; black;polished	4
31	7GCB-070045005-J	$\Phi 7$ Microphone protection water perforated film with plastic mesh	2
32	7MHP-4002-05A-W9	DP770 main unit top cover PC+ABS; texture; black	1
33	7MHL-4002-01-W	DP770 aluminum chasis ADC12; burnished	1
34	7MHR-7042-06B-W0	thermally conductive pad, black,3*6*9mm	1
35	3CR7-SMA-50JF-4	Antenna connector SMA-J, Flange installation	1
36	7MHR-4002-15A-W9	DP770 antenna connector Waterproof pad silicone;black	1
37	4MV3-KFF081522	$\phi 8\text{Dc}$ motor vibration KFF081522	1
38	7MHR-4002-17A-W9	DP770 Motor silicone pad silica gel; black	1
39	7MHS-4002-02A-W	DP770 Motor pressure pieces of stainless steel; natural color; Junyu, lead free	1
40	7MHR-4002-18A-W9	DP770 Discharge seating silicone; black	1
41	7MHP-4002-01A-W	TD7700 battery connector BC-2P-41PH-6.8H	1
42	7MHC-4002-02A-W	DP770 shielding cover holder — 43.4*32.3mm; cupronickel	1
43	7MBM-S4002-A	EMI Gasket 12*7*7 With double-sided adhesive	3
44	7MHC-4002-16A-W1	GPS shielding cover base, cupronickel; Junyu; Lead free	1
45	7MHC-4002-04A-W	DP770shielding cover holder 22.8*15.6mm; cupronickel	1
46	6PM7-4002-HMH	DP770-02 main board PCB ten-layer board	1



47	7SMF-020050M-MHHT-N1	M2*5 plum blossom iron hardened tooth machine screw, nickel plating	10
48	6PD7-4002-HPC	DP770PTT board PCB double side board	1
49	7MHS-4002-04A-W	DP770 PTT key METAL DOME4.0; SUS301	1
50	7MHS-4002-05A-W	DP770 Platooninsert tableting stainless steel,0.6mm	1
51	7MDZ-1737-04A-J5	KB-58L sticker 1 Barley paper,8*35*0.2	1
52	6SS1-4002-HL1G	Main flat cable	1
53	7MHC-4002-05A-W	DP770 shielding cover 23.3*16.1mm; cupronickel	1
54	7MHC-4002-17A-W1	GPS shielding cover cupronickel; Junyu; lead free	1
55	7MHC-4002-03A-W	DP770 shielding cover 43.9*32.8mm; cupronickel	1
56	7MHJ-4002-01A-W	GPS shielding cover conductive fabric 46.85x32.25x0.15mm	1
57	8ATX-400470-WC	DP770 dual mode antenna 400-470MHZGPS antenna	1
58	7MHP-4002-03A-W9	DP770 knob PC+ABS/TPU, grey	1
59	7MHS-1767-02B-W	PT6800Knob circlip stainless steelSUS304-1/2H, hardened	1
60	7NRC-077107040-Z	R 7200 Coding switch nut brass, zinc plating-black	1
61	7MHR-4002-13A-WC	DP770 Guide pillar silicone; transparent	1
62	7NRC-090110025-W1	Antenna connector copper nut	1
63	7MHR-4002-12A-W3	DP770 emergency key silica gel key; orange, PT021C	1

## 6. Tune Mode

It may need to check and adjust the parameters after parts replacement in maintenance.

### 6.1. Required parts in adjustment

- (1) Antenna adapter
- (2) Universal interface

### 6.2. Adjusting and checking method

#### 6.2.1. Frequency description

Model	400~470MHz										
Channel	Low Frequency	Mid-frequency	High frequency	F1	F2	F3	F4	F5	F6	F7	F8
TX frequency (MHz)	400.00	435.00	470	400	410	420	430	440	450	460	470
RX frequency (MHz)	400.05	435.05	469.95	400.05	410.05	420.05	430.05	440.05	450.05	460.05	469.95

Model	136~174MHz										
Channel	Low Frequency	Mid-frequency	High frequency	F1	F2	F3	F4	F5	F6	F7	F8
TX frequency (MHz)	136.00	158.00	174.00	136.00	140.00	146.00	152.00	158.00	164.00	170.00	173.975
RX frequency (MHz)	136.05	158.05	174.00	135.05	140.05	146.05	152.05	158.05	164.05	170.05	174.00

## 6.2.2. Adjustment Equipments

- (1) Comprehensive test instrument(HP8921 or similar equipment)
- (2) Computer and CPSP software
- (3) AEROFLEX 3920
- (4) spectrum analyzer

## 6.2.3. Adjustment instruction of TX

Item	Configuration	Test		Tool and Method		Remark
		Test equipment	Test Point	Tool	Method	
Frequency Stability	Set comprehensive instrument to tx mode	HP8921A or similar instrument	Connect the antenna port to RF IN/OUT port of instrument by antenna connector adapter	PC	1)Enter tune mode; 2)Double click frequency stability 3)Adjust the value in tune mode to make the tx frequency to be within+/-480Hz 4) Observe TX current 5) Click "Save" to save it.	≤±500Hz
Tx High Power	Set comprehensive instrument to tx mode	HP8921A or similar instrument			1)Enter tune mode; 2)Double click TX high power, and enter frequency F1 to F8 to adjust high power output at different frequency. 3)Adjust the value in tune mode to make the tx high power to be within 4W+/-0.2W 4) Click "Save" to save it.	1) Power:3.7W-4.5W; 2) Current:<1.8A
Tx Low Power	Set comprehensive instrument to tx mode				1)Enter tune mode; 2)Double click TX low power, and enter frequency F1 to F8 to adjust low power output at different frequency. 3)Adjust the value in tune mode to make the tx high power to be within 1W+/-0.2W 4) Observe TX current 5) Click "Save" to save it.	1) Power:0.7W-1.5W; 2) Current:<1A

Maximum Deviation	Set the test instrument to tx mode. Set HF(High filter) to 50Hz and LF(low filter) to 15KHz )	HP8921A or similar instrument	Connect the antenna port to RF IN/OUT port of instrument by antenna connector adapter	PC	<ol style="list-style-type: none"> <li>1) Enter tune mode;</li> <li>2) Double click "Maximum Deviation".</li> <li>3) Adjust the value in tune mode and view the FM deviation on the test instrument</li> <li>4) Make the FM deviation within <math>5.0 \pm 0.05\text{kHz}</math></li> <li>5) Click confirm to save</li> </ol>	4.95kHz-5.05kHz
Low frequency modulation deviation	Set comprehensive instrument to tx mode	HP8921A or similar instrument	Connect the antenna port to RF IN/OUT port of instrument by antenna connector adapter	PC	<ol style="list-style-type: none"> <li>1) Enter tune mode</li> <li>2) Double click" Low frequency modulation deviation" and enter to F1 to F8 to adjust different frequency.</li> <li>3) Adjust the value in tune mode and view the FM deviation on the instrument when AF Freq is 0.1kHz</li> <li>4) Make the FM deviation within <math>5.0 \pm 0.05\text{kHz}</math>.</li> <li>5) Click save to save the data.</li> </ol>	4.95kHz-5.05kHz
High Frqncy modulation deviation	Set comprehensive instrument to tx mode	HP8921A or similar instrument	Connect the antenna port to RF IN/OUT port of instrument by antenna connector adapter	PC	<ol style="list-style-type: none"> <li>1) Enter tune mode</li> <li>2) Double click" high frequency modulation deviation" and enter to F1 to F8 to adjust different frequency.</li> <li>3) Adjust the value in tune mode and view the FM deviation on the instrument when AF Freq is 6.0kHz</li> <li>4) Make the FM deviation within <math>5.0 \pm 0.05\text{kHz}</math>.</li> <li>5) Click save to save the data.</li> </ol>	4.95kHz-5.05kHz
VOX 1	Set comprehensive instrument to tx mode 1) AFGen1 Freq:1kHz; 2) AFGen1 Lvl:50mV	HP8921A or similar instrument	Connect mic port of the radio to audio out of test instrument	PC	<ol style="list-style-type: none"> <li>1) Enter tune mode</li> <li>2) Double click"VOX1.</li> <li>3) Click "Start", the radio will enter vox adjustment automatically.</li> <li>4) Click "stop" when the value is stable.</li> <li>5) Click save to save the data.</li> </ol>	Test: 1) The vox will activate then AFGen1 is set to 50mV. The vox will stop when AFGen1 is below 15mV.

VOX 10	Set comprehensive instrument to tx mode 1) AFGen1 Freq:1kHz; 2) AFGen1 Lvl: 5mV	HP8921A or similar instrument	Connect mic port of the radio to audio out of test instrument	PC	<ol style="list-style-type: none"> <li>1) Enter tune mode</li> <li>2) Double click"VOX10".</li> <li>3) Click "Start", the radio will enter vox adjustment automatically.</li> <li>4) Click "stop" when the value is stable.</li> <li>5) Click save to save the data.</li> </ol>	*
Low battery warning	*	multimeter	Battery connector	*	<ol style="list-style-type: none"> <li>1) Enter t tune mode</li> <li>2) Set the power supply voltage to 6.8V;</li> <li>3) Click save when value is stable.</li> </ol>	The low battery starts to work when the voltage is below 6.5V. The radio will power off when the voltage is below 5.8V. The radio can work when the voltage is above 7.2V.
CV Curve				PC	<ol style="list-style-type: none"> <li>1) Enter tune mode.</li> <li>2) Double click "TX CV Curve"</li> <li>3) Click "Start"</li> <li>4) After adjustment, click save</li> </ol>	Low point: $\geq 0.5V$ High point: $< 4.5V$

### 6.2.4. Receiver section adjustment instruction

Item	Configuration	Test		Tool and Method		Standard Requirement
		Test Equipment	Test point	Tool	Method	
Receiver sensitivity	<ol style="list-style-type: none"> <li>1)Set comprehensive instrument to RX mode</li> <li>2) Set RF Gen Freq to F1、F2、...、F8, Eg: Set RF Gen Freq to 469.95MHz when testing F8</li> <li>3) Set AFGen1 Freq to 1kHz Set AFGen1 to 3kHz</li> <li>4) Set HF(High filter) to 300Hz and LF(low filter) to 3KHz</li> </ol>	HP8921A or similar instrument	Connect the antenna port to RF IN/OUT port of instrument by antenna connector adapter, Connect universal connector of radio to audio in of test instrument by test cable	PC	<ol style="list-style-type: none"> <li>1) Enter tune mode</li> <li>2) Double click "receiver sensitivity". Enter F1 to F8 to adjust different frequency.</li> <li>3) Set input signal strange to -119dBm, adjust pc value to max the SINAD and the SINAD is above 12dB .</li> <li>4) Click save to save it.</li> </ol>	SINAD $\geq$ 12dB  W: -119dBm; N: -118dBm.

SQL1 Open	<ol style="list-style-type: none"> <li>1)Set comprehensive instrument to RX mode</li> <li>2) Set RF Gen Freq to test frequency</li> <li>3) Set Amplitude to -123dBm(25KHz) or -121dBm (12.5KHz)</li> <li>4) Set AFGen1 Freq to 1kHz</li> <li>5) Set FM to 3kHz (25KHz) or 1.5kHz (N)</li> </ol>	HP8921A or similar instrument	Connect the antenna port to RF IN/OUT port of instrument by antenna connector adapter	PC	<ol style="list-style-type: none"> <li>1. Enter tune mode</li> <li>2. Double click"SQL1 Open"and enter to F1 to F8 to adjust different frequency</li> <li>3. Click "Start".</li> <li>4. Click "Stop" when the value is stable.</li> <li>5. Click save</li> </ol>	Open:-119dBm Close -127dBm	
SQL1 Close	<ol style="list-style-type: none"> <li>1)Set comprehensive instrument to RX mode</li> <li>2) Set RF Gen Freq to test frequency</li> <li>3) Set Amplitude to -125dBm(25KHz) or -123dBm (12.5KHz)</li> <li>4) Set AFGen1 Freq to 1kHz</li> <li>5) Set FM to 3kHz (25KHz) or 1.5kHz (N)</li> </ol>				<ol style="list-style-type: none"> <li>1.Enter tune mode</li> <li>2. Double click"SQL1 Open"and enter to F1 to F8 to adjust different frequency</li> <li>3. Click "Start".</li> <li>4. Click "Stop" when the value is stable.</li> <li>5. Click save</li> </ol>		
SQL9 Open	<ol style="list-style-type: none"> <li>1)Set comprehensive instrument to RX mode</li> <li>2) Set RF Gen Freq to test frequency</li> <li>3) Set Amplitude to -116dBm</li> <li>4) Set AFGen1 Freq to 1kHz</li> <li>5) Set FM to 3kHz (25KHz) or 1.5kHz (N)</li> </ol>				<ol style="list-style-type: none"> <li>1.Enter tune mode</li> <li>2. Double click"SQL9 Open"and enter to F1 to F8 to adjust different frequency</li> <li>3. Click "Start".</li> <li>4. Click "Stop" when the value is stable.</li> <li>5.Click save</li> </ol>		Open:-115dBm Close -120dBm
SQL9 Close	<ol style="list-style-type: none"> <li>1)Set comprehensive instrument to RX mode</li> <li>2) Set RF Gen Freq to test frequency</li> <li>3) Set Amplitude to -119dBm</li> <li>4) Set AFGen1 Freq to 1kHz</li> <li>5) Set FM to 3kHz (25KHz) or 1.5kHz (N)</li> </ol>				<ol style="list-style-type: none"> <li>1.Enter tune mode</li> <li>2.Double click"SQL9 Close"and enter to F1 to F8 to adjust different frequency</li> <li>3. Click "Start".</li> <li>4. Click "Stop" when the value is stable.</li> <li>5.Click save</li> </ol>		

RSSI 1	1)Set comprehensive instrument to RX mode 2) Set RF Gen freq to 400MHz 3)Set Amplitude to -110dBm	HP8921A or similar instrument	Connect the antenna port to RF IN/OUT port of instrument by antenna connector adapter	PC	1.Enter tune mode 2.Double click "RSSI1" 3. Click "Start". 4. Click "Stop" when the value is stable. 5.Click save	The RSSI is displayed one bar when input signal is -107dBm The RSSI is displayed 4 bars when input signal is -70dBm.
RSSI 4	1)Set comprehensive instrument to RX mode 2) Set RF Gen freq to 400MHz 3)Set Amplitude to -80dBm	HP8921A or similar instrument	Connect the antenna port to RF IN/OUT port of instrument by antenna connector adapter	PC	1.Enter tune mode 2.Double click "RSSI4" 3. Click "Start". 4. Click "Stop" when the value is stable. 5.Click save	
CV Curve	Test the VCO voltage			PC	1.Enter tune mode 2.Double click "CV Curve" 3. Click "Start". 4. Click "Stop" when the value is stable. 5.Click save	Low point: >=0.5V; High point: < 4.5V。

### 6.2.5. GPS Performance Test Instruction

Item	Test Environment	Test Equipment	Test Method	Standard Requirement
GPS Position Time	1) Change the radio to digital channel 2) Install standard double mode antenna 3) Put the radio in the outside area without high building surround it.	1) DP770 2) Timing tool	1) Remove the battery 2) Install the battery 3) Open GPS function in the menu and enter "gps information menu" 4) Activate timing tool 5) Check the time when gps positions successful.	1、 <b>TTF (cold start) Time to first fix</b> <1minute 2、 <b>TTF (hot start) Time to first fix</b> <10 seconds 3、 <b>Horizontal Accuracy</b> <10 meters

## 7. Main Specifications

General Specifications	
Frequency	UHF1: 400-470MHz, VHF: 136-174MHz
Channel Capacity	1024
Channel Spacing	12.5kHz/20kHz/25kHz
Weight	362g ( with battery and antenna)
Dimension	138mm*62mm*38mm
Display	1.8 Inches 65535 Color Display
Battery Capacity	7.4V 2000mAH Li-ion
Working Time ( 5-5-90 )	Analog: 13.5 Hours Digital: 15 Hours
Environmental Operating Conditions	
Working Temperature	-30°C ~+60°C
Storage Temperature	-40°C ~+85°C
Waterproof/Dustproof	IP67
Electrostatic Defending	IEC 61000-4-2 ( Level 4 )  ±8kV ( Touch )  ±15kV ( Air )
MILST	MIL-STD-810 C/D/E/F/G
Humidity	MIL-STD-810 C/D/E/F/G
Shock and Vibration	MIL-STD-810 C/D/E/F/G
Receiver Part	
Frequency Stability	±1.5ppm
Analog Sensitivity	0.3uV ( 12dB SINAD ) /0.22uV ( 12dB SINAD , Typical )



<b>Digital Sensitivity</b>	0.3uV ( 5% BER )
<b>Intermodulation</b>	ETSI: 65dB    TIA603: 70dB
<b>Adjacent Channel Selectivity</b>	ETSI/TIA603: 60dB@12.5kHz , 70dB@20/25kHz
<b>Spurious Response Rejection</b>	ETSI/TIA603: 70dB
<b>Conducted Spurious Emission</b>	-57dBm
<b>Block</b>	ETSI: 84dB    TIA603: 80dB
<b>Rated Audio Power</b>	0.5W
<b>Rated Audio Distortion</b>	<3% ( Typical )
<b>Hum and Noise</b>	-40dB@12.5kHz/-43dB@20kHz/-45dB@25kHz
<b>Audio Response</b>	+1dB ~ -3dB

<b>Transmitter</b>	
<b>Frequency Stability</b>	±1.5ppm
<b>RF Power output</b>	Low: 1W , High: 4W(UHF)/5W(VHF)
<b>Hum and Noise</b>	-40dB@12.5kHz/-43dB@20kHz/-45dB@25kHz
<b>Conducted/Radiated Emission</b>	-36dBm@<1GHz , -30dBm@>1GHz
<b>Adjacent Channel Power</b>	60dB@12.5kHz , 70dB@20/25kHz
<b>FM Modulation</b>	11K0F3E@12.5kHz,14K0F3E@20kHz,16K0F3E@25kHz
<b>4FSK Modulation</b>	12.5kHz ( data only ) : 7K60FXD 12.5kHz ( data and voice ) : 7K60FXE
<b>Modulation Limit</b>	±2.5kHz@12.5kHz, ±4kHz@20kHz, ±5kHz@25kHz
<b>Audio Response</b>	+1dB~-3dB

<b>Audio Distortion</b>	3% ( Typical )
<b>Vocoder</b>	AMBE++
<b>Digital Data Protocol</b>	ETSI TS 102 361-1, -2, -3

<b>GPS</b>	
<b>TTF ( cold start ) Time to first fix</b>	<1min
<b>TTF ( Hot start ) Time to first fix</b>	<10s
<b>Horizontal Accuracy</b>	<10meters

## 8. Repairing and Testing Equipments

<b>Installations</b>	<b>Main Specifications</b>
<b>RF Standard Signal Generator (SSG)</b>	Frequency: 10MHZ to 3GHz Modulation: Frequency modulation and external modem Output: -127dBm/0.1uv-- -47dBm/1mv
<b>Dynamometer Instruments</b>	Input Impedance: 50Ω Operating Frequency: 100MHZ-1000MHz Range: 10W
<b>Frequency Deviation Meter</b>	Frequency: 100MHZ-1000MHz
<b>Digital RMS Multimeter</b>	Range: DC 10mv-10v Input Impedance: 10Mega Ohm Impedance
<b>Oscillograph</b>	30MHZ- 100MHz
<b>High Sensitive Frequency Counter</b>	Frequency: 100-1000MHz Frequency Stability: ≤ 0.2ppm
<b>Ammeter</b>	5A

<b>Audio Frequency Voltmeter</b>	Frequency: 50Hz-10KHz Voltage: 1mv-10v
<b>Tone Generator</b>	Frequency: 50Hz - 5KHz or higher Output: 0-1v
<b>Distortion Meter</b>	Power: when 1KHz, $\leq 3\%$ Input PWL: 50mv-10vms
<b>Spectrum analyzer</b>	Range:100-3GHz or higher
<b>16<math>\Omega</math> Dummy Load</b>	16 $\Omega$ , 3W
<b>Power Supply</b>	Output Voltage 5v- 30v, current:5A

## 9. Basic Troubleshooting

No.	Problem	Causes and Solutions
1	The radio cannot be powered on.	A. The battery may be used up. Recharge it or change the battery to try again. B. The power ON/OFF key may suffer from poor contact. Clear the metal dome with alcohol and try again. C. The power binding post isn't connected with battery. Re-install it and try again. D. The power is connected inversely which leads to the power protective tube F901 open. Replace the protective tube F901 and try again.
2	You cannot communicate with other members	A. The frequency settings may be different from others. Set your TX/RX frequencies to be the same as others. B. The CTCSS/CDCSS signaling may be different from others. Set your CTCSS/CDCSS signaling to be the same as others. C. Your place may be too far away from the others, beyond the radio's coverage area.
3	The radio cannot receive signals	A. The antenna may get looser or may be improperly installed. Re-install the antenna. B. The frequency settings may be different from others. Set your TX/RX frequencies to be the same as others. C. Your place may be too far away from the others, beyond the radio's coverage area.
4	During receiving, LED is green but no voice.	A. Check whether the volume is smallest or not. If so, increase the volume. B. Check whether the speaker is broken or not. If so, change the speaker.

5	GPS cannot locate your position.	<p>A. Check whether the antenna is GPS+UHF dual band or not. If not, use a GPS+UHF dual band antenna to replace the old one.</p> <p>B. Check whether the GPS setting is correct or not. If not, set it correctly.</p> <p>C. Maybe there is some other RF interference around the radio's place. Go to an open sky place and try again.</p>
6	CPS programming failed.	<p>A. Connection between the radio and PC is not good enough. Check and try again.</p> <p>B. Earphone interface board has poor contact with external programming cable. If so, change the Earphone interface board.</p>

## Appendix 1 Material List( Electrics Parts) 400-470MHz

NO.	Part Number	Name	Quantity	Position Mark
1	6SS2-4002B-HMD	DP770 Main Board suite (BD+GPS)	1	
2	6SS1-4002B-HMC	DP770-02 main board SMD suite (BD+GPS)	1	
3	0SS1-4002B-HME	DP770-02 main board SMD units(BD+GPS)	1	
4	1DR1-1SR154-400	R SMD commutation diode	1	D903
5	1DS1-DA2S10100L	R SMD switch diode	9	D110,D111,D113,D701,D702, D703, D704,D15,D506
6	1DS1-DAN222	R SMD switch diode	1	D904
7	1DS1-HSC277	R SMD switch diode	1	D112
8	1DS1-HVC131	R SMD switch diode	4	D301,D302, D303, D304
9	1DV1-1SV278	R SMD varactor	1	D109
10	1DV1-1SV305	R SMD varactor	1	D201
11	1DV1-HVC350B	R SMD varactor	4	D103,D104,D107,D108
12	1DV1-HVC376B	R SMD varactor	9	D101,D102,D105,D106,D202,D203, D204, D205, D206
13	1DZ1-MMSZ4678T1 G	SMD voltage regulated diode	1	D905
14	1DZ1-PESD12VS1U B	SMD voltage regulated diode	2	D901,D902
15	1DZ1-PESD3V3S1U B	SMD voltage regulated diode	1	D907
16	1DZ1-PESD5V0S1U	SMD voltage regulated diodeDP770,	1	D906

	B	DP780, STP,KH620		
17	1ID1-MXD2020ML	SMD general logic IC (accelerated sensor)	1	U702
18	1IL1-NJM2904V	R SMD linear IC	2	U106,U303
19	1IL1-TDA8547TS	E General linear IC	1	U802
20	1IM1-MT47H64M16	SMD memorizer IC	1	U905
21	1IP1-OMAPL138EZ WT3	Dual core CPU	1	U906
22	1IS1-AD9864	IF Digital System	1	U201
23	1IS1-ADE1L	SMD passive mixer	1	Z201
24	1IS1-ADS1015	AD convert IC	1	U701
25	1IS1-MC74VHC1GT6 6	High-speed CMOS simulated switch IC	2	U110,U111
26	1IS1-SKY72310	PLL Chip	1	U103
27	1IS1-TC75W51FU	R SMD Specialized IC	1	U703
28	1IS1-TLV320AIC14K	CODEC IC	1	U801
29	1IS1-TLV5614	DA convertor IC	1	U105
30	1IS1-TPS62110	Power Chip	1	U901
31	1IS1-TPS65023	Power management Chip DP770, DP780, KH620D,STR,STP	1	U902
32	1IS1-XC6204B302M R	SMD voltage regulated	1	U112
33	1IS1-XC6204B502M R	R SMD voltage regulated	2	U101,U202
34	1TC1-UMC4	R SMD multiunit tube	4	U107,U108, U109,U301
35	1TF1-2SK3019TL	R SMD FET	2	Q902, Q4
36	1TF1-RD01MUS2	E R SMD FET	1	Q303

37	1TF1-RD07MUS2B	E R SMD FET	1	Q304
38	1TF1-ST2301	R SMD FET	4	Q905,Q907,Q908,Q901
39	1TT1-2SC3356-R24	R SMD triode	4	Q103,Q104, Q302,Q305
40	1TT1-2SC4617-R	R SMD triode	3	Q102,Q105,Q107
41	1TT1-2SC5006	SMD triode	6	Q201,Q203,Q204,Q206,Q207,Q301
42	1TT1-AT41511	Low Noise NPN triode	1	Q205
43	1TT1-DTC144EE	R SMD triode	8	Q903,Q1,Q801,Q805,Q30,Q202,Q306,Q309
44	1TT1-FMMT717TA	R SMD triode	2	Q106,Q307
45	1TT1-FMMT720	SMD triode	1	Q906
46	1TT1-MMBT3904	SMD triode	1	Q904
47	2CC1-10-C0G500-10 0D	R flake multi-layer capacitor	30	C903,C925,C928,C932,C935,C938,C941,C956,C959,C962,C965 ,C968,C971,C974,C977,C980,C981,C987,C990,C993,C996,C99 9,C1002,C1006,C1008,C1012,C1015,C1017,C1020,C1023
48	2CC1-10-C0G500-10 1J	R flake multi-layer capacitor	71	C110,C141,C201,C202,C203,C204,C205,C222,C223,C227,C229 ,C244,C909,C926,C929,C931,C934,C937,C940,C955,C958,C96 3,C966,C969,C973,C975,C978,C988,C992,C994,C997,C1001,C 1004,C1005,
49	2CC1-10-C0G500-12 0J	R flake multi-layer capacitor	6	C215,C216,C305,C311,C312,C356
50	2CC1-10-C0G500-15 0J	R flake multi-layer capacitor	2	C245,C246
51	2CC1-10-C0G500-15 1J	R flake multi-layer capacitor	24	C116,C123,C139,C148,C157,C158, C159,C162,C163, C164,C166,C168,C177,C178,C257,C258,C260,C262,C302,C309 ,C315,C321,C327,C346
52	2CC1-10-C0G500-18 1J	R flake multi-layer capacitor	1	C221
53	2CC1-10-C0G500-1R 0C	R flake multi-layer capacitor	7	C118,C150,C301,C945,C947,C949,C952

54	2CC1-10-C0G500-1R 5C	R flake multi-layer capacitor	2	C117,C149
55	2CC1-10-C0G500-20 0J	R flake multi-layer capacitor	1	C320
56	2CC1-10-C0G500-22 0J	R flake multi-layer capacitor	2	C124,C268
57	2CC1-10-C0G500-27 0J	R flake multi-layer capacitor	2	C213,C214
58	2CC1-10-C0G500-27 1J	flake multi-layer capacitor	9	C842,C358,C359, C613, C810,C811,C818,C819,C828
59	2CC1-10-C0G500-2R 0D	flake multi-layer capacitor	1	C266
60	2CC1-10-C0G500-30 0J	flake multi-layer capacitor	1	C248
61	2CC1-10-C0G500-33 0J	R flake multi-layer capacitor	64	C1027,C1028, C1029, C1030, C1031, C1032, C1033, C1034, C1035, C1036, C1037, C1038, C1039, C1040, C1041, C1042, C1043, C1044, C1045, C1046, C1047, C1048, C1049, C1050, C1051, C1052, C1053, C1054, C1055, C1056,
62	2CC1-10-C0G500-3R 0B	flake multi-layer capacitor	1	C269
63	2CC1-10-C0G500-3R 0D	flake multi-layer capacitor	2	C252,C263
64	2CC1-10-C0G500-47 0J	R flake multi-layer capacitor	13	C236,C267,C271,C707,C709,C943,C944,C946,C948,C950,C951 ,C953,C954
65	2CC1-10-C0G500-47 1J	flake multi-layer capacitor	9	C314,C340,C341,C345,C354,C614,C615,C617,C621
66	2CC1-10-C0G500-4R 0B	flake multi-layer capacitor	2	C251,C330
67	2CC1-10-C0G500-4R 0D	flake multi-layer capacitor	3	C254,C255,C265
68	2CC1-10-C0G500-4R	R flake multi-layer capacitor	1	C901



	7C			
69	2CC1-10-C0G500-560J	R flake multi-layer capacitor	2	C317,C328
70	2CC1-10-C0G500-5R6B	flake multi-layer capacitor	2	C250,C283
71	2CC1-10-C0G500-6R0C	R flake multi-layer capacitor	3	C129,C130,C264
72	2CC1-10-C0G500-7R0B	flake multi-layer capacitor	2	C253,C277
73	2CC1-10-C0G500-8R0B	flake multi-layer capacitor	1	C274
74	2CC1-10-C0G500-9R0C	flake multi-layer capacitor	1	C307
75	2CC1-10-X5R100-105K	flake multi-layer capacitor	10	C36,C38,C411,C412,C703,C710,C1136,C612,C812,C814
76	2CC1-10-X5R100-474K	R flake multi-layer capacitor	1	C154
77	2CC1-10-X5R6R3-225K	R flake multi-layer capacitor	11	C964,C970,C972,C989,C991,C995,C1000,C1007,C1009,C1013,C1014
78	2CC1-10-X7R100-224K	R flake multi-layer capacitor	2	C704,C712
79	2CC1-10-X7R160-104K	R flake multi-layer capacitor	56	C107,C119,C120, C121,C133,C134, C135, C136, C137,C140,C147,C155,C156,C160,C165,C167,C179,C217,C218,C224,C225,C230,C232,C233,C235,C238,C240,C297,C344,C4,C701,C705,C708,C906,C982,C983,C986,C1061,C1135,C616,C803,
80	2CC1-10-X7R160-333K	R flake multi-layer capacitor	2	C815,C816
81	2CC1-10-X7R160-47	R flake multi-layer capacitor	1	C357

	3K			
82	2CC1-10-X7R250-22 3K	R flake multi-layer capacitor	2	C706,C711
83	2CC1-10-X7R500-10 2K	R flake multi-layer capacitor	25	C153,C212,C5,C6,C25,C927,C930,C933,C936,C939,C942,C957, C960,C967,C976,C979,C984,C985,C998,C1003,C1018,C1021,C 1025,C1026,C916
84	2CC1-10-X7R500-10 3K	R flake multi-layer capacitor	38	C122,C125,C171,C173,C206,C207, C208, C209, C210,C211,C219,C220,C226,C228,C234,C237,C239,C243,C247 ,C249,C256,C272,C275,C276,C278,C280,C287,C288,C306,C31 6,C322,C353,C355,C802,C807,C823,C831,C824
85	2CC1-10-X7R500-27 3K	R flake multi-layer capacitor	1	C342
86	2CC1-10-X7R500-33 2K	R flake multi-layer capacitor	1	C152
87	2CC1-16-C0G500-10 0D	R flake multi-layer capacitor	4	C111,C113,C114,C115
88	2CC1-16-C0G500-12 0J	R flake multi-layer capacitor	1	C326
89	2CC1-16-C0G500-13 0J	R flake multi-layer capacitor	1	C146
90	2CC1-16-C0G500-15 0J	R flake multi-layer capacitor	1	C338
91	2CC1-16-C0G500-1R 0B	flake multi-layer capacitor	1	C151
92	2CC1-16-C0G500-1R 5B	flake multi-layer capacitor	1	C335
93	2CC1-16-C0G500-20 0J	R flake multi-layer capacitor	1	C349
94	2CC1-16-C0G500-22 0J	R flake multi-layer capacitor	1	C145
95	2CC1-16-C0G500-24	R flake multi-layer capacitor	1	C339

	0J			
96	2CC1-16-C0G500-27 0J	R flake multi-layer capacitor	1	L304
97	2CC1-16-C0G500-2R 0B	flake multi-layer capacitor	2	C332,C337
98	2CC1-16-C0G500-3R 0B	flake multi-layer capacitor	1	C169
99	2CC1-16-C0G500-3R 5C	R flake multi-layer capacitor	1	C333
100	2CC1-16-C0G500-43 0J	R flake multi-layer capacitor	1	C325
101	2CC1-16-C0G500-47 0J	R flake multi-layer capacitor	1	C176
102	2CC1-16-C0G500-4R 0B	flake multi-layer capacitor	2	C334,C350
103	2CC1-16-C0G500-4R 5B	flake multi-layer capacitor	1	C112
104	2CC1-16-C0G500-56 0J	R flake multi-layer capacitor	1	C331
105	2CC1-16-C0G500-5R 0B	flake multi-layer capacitor	2	C142,C170
106	2CC1-16-C0G500-68 0JQ	flake multi-layer capacitor	1	C175

107	2CC1-16-C0G500-6R0C	R flake multi-layer capacitor	2	C161,C144
108	2CC1-16-C0G500-R50B	R flake multi-layer capacitor	1	C336
109	2CC1-16-X7R6R3-106K	SMD ceramic capacitor	7	C702,C804,C805,C821,C826,C809,C37
110	2CC1-16-Y5V100-225Z	flake multi-layer capacitor	1	C921
111	2CC1-16-Y5V160-105Z	R flake multi-layer capacitor	6	C323,C801,C806,C820,C907,C919
112	2CC1-20-Y5V160-106Z	flake multi-layer capacitor	3	C915,C917,C923
113	2CC1-32-X5R100-476K	SMD flake multi-layer capacitor	10	C101,C102,C105,C106,C241,C242,C352,C902,C904, C2
114	2CT1-TP20-100-100M	R SMD tantalum capacitor	2	C911, C143
115	2CT1-TS32-100-220M	SMD tantalum capacitor	3	C1,C830, C913
116	2CT1-TS32-100-4R7M	R SMD tantalum capacitor	1	C839
117	2CT1-TS32-160-100M	R SMD tantalum capacitor	11	C103,C104,C108,C109,C172,C180,C181, C182, C183, C184,C360
118	2CT1-TS32-250-2R2	SMD tantalum capacitor	2	C127,C138

	M			
119	2CT1-TS32-350-R10 M	R SMD tantalum capacitor	1	C126
120	2CT1-TS32-350-R33 M	R SMD tantalum capacitor	1	C128
121	2LH1-R401R5-R02-0 5	SMD air-core inductance	1	L310
122	2LH1-R401R5-R03-0 5	R SMD air-core inductance	2	L311,L312
123	2LH1-R401R5-R04-0 5	R SMD air-core inductance	6	L207,L208,L211,L212,L313,L314
124	2LH1-R401R5-R08-0 5	R SMD air-core inductance	1	L309
125	2LH1-R501R5-R05-0 5	SMD air-core inductance	1	L306
126	2LL1-16-10NJ	Laminated inductance	4	L225,L226,L228,L230
127	2LL1-16-18NG	Laminated inductance	2	L108,L2
128	2LL1-16-1R0K	R Laminated inductance	1	L218
129	2LL1-16-22NJ	R Laminated inductance	5	L301,L302,L305,L317, L209
130	2LL1-16-27NGA	Laminated inductance	1	L206
131	2LL1-16-3N9S	R Laminated inductance	3	L234,L235,L308
132	2LL1-16-3R3K	R Laminated inductance	1	L204
133	2LL1-16-R10JB	Laminated inductance	5	L213,L224,L227,L229,L231
134	2LL1-16-R82K	Laminated inductance	2	L101,L109
135	2LL1-30-VLS3012T1 00M	Laminated inductance	4	L901,L902,L903, L904
136	2LW1-16UC-150J	R SMD coil inductance	1	L112
137	2LW1-16UC-181J	SMD coil inductance	3	L210,L214,L318
138	2LW1-16UC-270G	SMD coil inductance	2	L221,L222
139	2LW1-16UC-330G	SMD coil inductance	2	L102,L220

140	2LW1-16UC-R33G	SMD coil inductance	7	L104,L105,L107,L110,L111,L114,L217
141	2LW1-20UC-120GA	SMD coil inductance	1	L103
142	2LW1-20UC-221J	R SMD coil inductance	1	L316
143	2LW1-20UC-331J	SMD coil inductance	1	L201
144	2LW1-20UC-8R2J	SMD coil inductance	1	L113
145	2LW1-25UC-103J	R SMD coil inductance	2	L202,L203
146	2LW1-25UC-332K	SMD coil inductance	1	L205
147	2RE1-10-1003	SMD precision resistor	26	R31,R32,R830,R822,R706, R133,R134,R138,R207,R222,R223,R228,R229,R316,R317,R334 ,R339,R37,R38,R626,R628,R635,R705,R711,R722,R928
148	2RE1-10-2003	SMD precision resistor	1	R702
149	2RS1-10-000O	R flake resistor	51	R30,R812,R710,R721,R725,R802,R803,R805,R814,R815, R816,R869,R926,R927,R40,R41,R115,R116,R119,R123,R144,R 146,R151,R152, R153,R156,R161,R164,R179,R183,R184, R185,R197,R198,R199,R206,R217,R241, R242,
150	2RS1-10-100J	R flake resistor	3	R826,R868,R911
151	2RS1-10-101J	R flake resistor	21	R117,R118,R120,R129,R224,R253,R268,R271,R272,R274,R277 ,R286,R290,R293,R294,R296,R304,R810,R819,R829,R901
152	2RS1-10-102J	R flake resistor	13	R158,R159,R203,R205,R208,R341,R17,R39,R624,R625,R627,R 634,R905
153	2RS1-10-103J	R flake resistor	48	R823,R827,R33,R34,C231,R121,R124,R127,R128,R139,R142,R 147,R148,R204,R209,R210,R225,R243,R325,R813,R817,R825, R916,R917, R918, R919, R920, R921,R923,R924, R925,R929,R9,R141,R187,R188, R189, R190,R263,R264,R269,R270,R276,R321,R910,R912,R915,R922
154	2RS1-10-105J	R flake resistor	2	R715,R718
155	2RS1-10-121J	R flake resistor	3	R114,R135,R136
156	2RS1-10-123J	R flake resistor	2	R130, R907

157	2RS1-10-124J	R flake resistor	2	R167,R236
158	2RE1-10-2200	SMD precision resistor	2	R305,R307
159	2RS1-10-151J	R flake resistor	1	R233
160	2RS1-10-152J	R flake resistor	1	R323
161	2RS1-10-153J	R flake resistor	2	R713,R716
162	2RS1-10-154J	R flake resistor	2	R104, R906
163	2RS1-10-182J	R flake resistor	1	R132
164	2RS1-10-183J	R flake resistor	2	R712,R719
165	2RS1-10-184J	R flake resistor	3	R213,R221,R23
166	2RS1-10-202J	R flake resistor	4	R106,R192, R808, R903
167	2RS1-10-203J	R flake resistor	5	R122,R202,R232,R336,R701
168	2RS1-10-220J	R flake resistor	9	R306,R175,R176, R177,R178,R180,R181,R342,R343
169	2RS1-10-222J	R flake resistor	5	R27,R345,R804,R806,R245
170	2RS1-10-224J	R flake resistor	4	R103,R168,R315,R333
171	2RS1-10-225J	flake resistor	2	R318,R332
172	2RS1-10-243J	R flake resistor	1	R302
173	2RS1-10-271J	R flake resistor	2	R344, R811
174	2RS1-10-272J	R flake resistor	6	R360,R1,R200,R259,R260,R261
175	2RS1-10-273J	R flake resistor	2	R714,R720
176	2RS1-10-330J	R flake resistor	1	R100
177	2RS1-10-331J	R flake resistor	1	R238
178	2RS1-10-332J	R flake resistor	2	R125,R909
179	2RS1-10-333J	R flake resistor	1	R327

180	2RS1-10-363J	R flake resistor	1	R335
181	2RS1-10-392J	R flake resistor	3	R108,R226,R227
182	2RS1-10-470J	R flake resistor	3	R113,R215,R219
183	2RS1-10-471J	R flake resistor	2	R340, R611
184	2RS1-10-472J	R flake resistor	12	R4,R143,R234,R703,R704,R801,R807,R913,R914,R12,R15,R36
185	2RS1-10-473J	R flake resistor	15	R137,R322,R171,R172, R173, R174,R279,R280,R283,R284,R287,R288,R297,R298,R908
186	2RS1-10-510J	flake resistor	4	R191,R230,R308,R329
187	2RS1-10-511J	R flake resistor	1	R201
188	2RS1-10-514J	flake resistor	1	R904



189	2RS1-10-562J	R flake resistor	2	R107,R235
190	2RS1-10-680J	R flake resistor	2	R109,R809
191	2RS1-10-682J	R flake resistor	2	R310,R338
192	2RS1-10-684J	R flake resistor	1	R214
193	2RS1-10-6R8J	flake resistor	4	R110,R111, R112,R145
194	2RS1-10-753J	R flake resistor	1	R220
195	2RS1-10-822J	R flake resistor	3	R126,R131,R231
196	2RS1-10-823J	R flake resistor	1	R328
197	2RS1-16-000O	R flake resistor	6	L216,L219,L303,L307,R170,R157
198	2RS1-16-102J	R flake resistor	2	R348,R707
199	2RS1-16-181J	R flake resistor	1	L215
200	2RS1-16-271J	R flake resistor	1	R330
201	2RS1-16-302J	flake resistor	1	R708

202	2RS1-20-000O	R flake resistor	1	FB901
203	2RS1-32-R39J	R flake resistor	3	R319,R320,R337
204	2RS2-20-101J08B	SMD Network resistor	25	RN1,RN2, RN3, RN4, RN5, RN6,RN8,RN9, RN10, RN11,RN14,RN15, RN16, RN17, RN18, RN19, RN20, RN21, RN22,RN24,RN25, RN26, RN27, RN28, RN29
205	2RT1-NTH5G16P40B 333J	SMD thermistor	1	R326
206	3CB1-DF23C-50DS	SMD board-to-board connector DP770 DP780	1	J902
207	3CM1-TFC-008-J	Flat TF clutch base	1	J4
208	3CP1-TPS76301	LDO power regulator	3	U102,U113,U5
209	3FW1-42932-302320	R SMD fuse	1	F901
210	5FE1-BLM11A601S	R SMD EMI suppression filter	4	FB202,FB203, FB204,FB301
211	5FE1-BLM18AG121S N1D	SMD EMI suppression filter	15	FB701,FB801,FB802, FB803,FB806,FB908,FB909, FB910, FB911, FB912, FB913, FB914, FB915,FB917,FB919
212	5FE1-BLM18PG181S N1	SMD EMI suppression filter	10	FB101,FB102,FB702,FB703,FB905,FB906, FB907,R193,R194,FB201
213	5FE1-BLM21P300S	R SMD EMI suppression filter	3	FB302,FB303, FB304
214	5FE1-BLM21PG221S N1	SMD EMI suppression filter	4	FB808,FB921,R902,R932
215	5OT1-12R8-CEC3-05 03	R SMD temperature compensated crystal oscillator	1	U104
216	5XC1-19R2-TKL3056 B	SMD crystal oscillator DP770 STP KH620	1	U114
217	5XC1-73R4-D73312	crystal oscillator	1	Z202

	GQ12			
218	5XT1-MC146-32R76 K	E SMD Ceramic Resonator	1	X503
219	6BLS-4814-03327U	SMD button battery (DP770, DM890, PT7800,219,620D)	1	BT1
220	7MHP-4002-01A-W	TD7700 battery connector	1	J901
221	2CC1-16-C0G500-10 1J	R flake multi-layer capacitor	1	C26
222	2RS1-16-222J	R flake resistor	1	FB920
223	2LL1-16-2N2S	R Laminated inductance	2	L1,L3
224	2CC1-10-C0G500-2R 5B	R flake multi-layer capacitor	2	C1134,C1153
225	2CC1-10-C0G500-2R 0B	flake multi-layer capacitor	2	C1132,C1143
226	1DR1-BAT54C	SMD schottky diode	1	D17
227	1TF1-BSH203	SMD FET	1	Q2
228	1MR1-MC-1010B	GPS/BEIDOU dual module (DP770 780 DM880)	1	U4
229	1IS1-SKY65709-81	GPS front end module pack DP770 DP780	1	U8
230	7MHC-4002-02A-W	DP770 shield cover bracket1	1	S2
231	7MHC-4002-04A-W	DP770 shield cover bracket2	1	S3
232	7MHC-4002-16A-W1	GPS shield cover base	1	S4
234	1IS1-XC6228D122V R	SMD Specialized IC	1	U6
235	2CC1-32-Y5V100-22 6Z	flake multi-layer capacitor	4	C905,C914,C918,C922
236	2CC1-10-C0G500-5R 0C	R flake multi-layer capacitor	1	C7
237	2CC1-10-X7R500-18	flake multi-layer capacitor	1	C343

	3K			
238	2CC1-10-X7R500-15 3K	R flake multi-layer capacitor	2	C319,C313
239	2RE1-10-1002	SMD precision resistor	6	R617,R618, R619, R620, R621, R622
240	2CC1-10-C0G500-16 0J	flake multi-layer capacitor	1	C282
241	2RS1-10-221J	R flake resistor	1	R240
242	2CC1-16-X7R160-10 4K	flake multi-layer capacitor	2	C3,C8
243	7PLJ-025006-T01A	High Temperature Sticker	1	
244	1IP1-0DP770-R01	DP770 burning chip	1	U904
245	1IM1-NANDS34ML01 G1	SMD Memorizer IC	1	U904
246	9FSO-DP770V081	DP770-02 Firmware Software	1	
247	6SS2-4002-HKC	DP770 keypad SMD suite	1	
248	0SS2-4002-HKA	DP770 keypad plug-in units	1	
249	6SS1-4002-HKG	DP770 keypad SMD suite)	1	
250	0SS1-4002-HKG	DP770 keypad plug-in units	1	
251	2CC1-10-X5R100-10 5K	flake multi-layer capacitor	11	C1,C24,C25,C26,C411,C413,C416,C417,C419,C423,C424
252	2CC1-10-X7R500-10 3K	R flake multi-layer capacitor	2	C2,C3
253	2CC1-10-X7R500-27 1K	R flake multi-layer capacitor	1	C8
254	2CC1-10-X7R500-47 1K	R flake multi-layer capacitor	8	C27,C28,C426,C428,C430,C432,C434,C436
255	2CC1-10-X5R100-10 4K	R flake multi-layer capacitor	8	C412,C414,C415,C418,C420,C421,C422,C425
256	2CC1-10-C0G500-10 1J	R flake multi-layer capacitor	6	C427,C429,C431,C433,C435,C437

257	1DR1-MM3Z12VT1G	Antistatic zener diode	5	D1,D5,D6,D29,D30
258	1DR1-ESD9B5	TVS diode	13	D3,D4,D7,D8,D9,D10,D11,D12,D13,D14,D15,D27,D28
259	5FE1-BLM15BB121S N1	SMD EMI suppression filter	7	FB1,FB6,FB69,FB70,FB71,FB72,FB73
260	3CB1-7650-20	Female socket	2	J1,J3
261	4PE1-16-F9	SMD LED	8	LED1,LED2,LED3,LED4,LED5,LED6,LED9,LED10
262	4PE1-06-F5	SMD LED	1	LED7
263	4PE1-06-F2	SMD LED	1	LED8
264	3ST1-SKRTLBE010	R SMD touch switch	1	P1
265	1TT1-FMMT717TA	R SMD triode	1	Q1
266	1TT1-DTC144EE	R SMD triode	3	Q2,Q3,Q4
267	1TF1-ST2301	R SMD FET	1	Q6
268	2RS1-10-471J	R flake resistor	1	R2
269	2RS1-10-472J	R flake resistor	2	R4,R5
270	2RS1-10-104J	R flake resistor	2	R11,R58
271	2RS1-10-331J	R flake resistor	8	R13,R14,R16,R17,R18,R19,R61, R62
272	2RS1-10-102J	R flake resistor	5	R22,R24,R25,R1,R3
273	2RS1-10-000O	R flake resistor	6	R59,R60,R65,R66,R551,R552
274	2RS1-10-272J	R flake resistor	1	R67
275	2RS1-10-103J	R flake resistor	4	R547,R548,R549,R550
276	3CB1-DF23C-50DP	SMD board-to-board connector	1	U3
277	1IM1-TCA8418	I2C control keypad scan IC	1	U926
278	6PM7-4002-HKG	DP770KEY-LCD PCB board	1	
279	3FW1-0603L025	Fuse	1	F901
280	2CC1-10-X5R6R3-22 5K	R flake multi-layer capacitor	4	C439 ,C440,C441,C438
281	2RS1-10-4R7J	R flake resistor	1	FB5
282	6SS1-4002-HL1G	DP770 main ribbon cable SMD suite	1	
283	0SS1-4002-HL1G	DP770 main ribbon cable SMD unites	1	

284	3CB1-DF23C-50DS	SMD board-to-board connector	1	U2
285	6PD7-4002-HL1H	DP770 main ribbon cable	1	
286	3CB1-DF23C-50DP	SMD board-to-board connector	1	U1
287	6SS2-4002-HL2D	DP770 channel knob connecting wire suite	1	
288	0SS2-4002-HL2B	DP770 channel knob connecting wire plug in units	1	
289	3SE3-RE11	Channel Knob (DP770,AP670	1	J4001
290	6SS1-4002-HL2D	DP770 channel knob connecting wire board SMD suite	1	
291	0SS1-4002-HL2D	DP770 channel knob connecting wire board SMD suite	1	
292	3CB1-1505-20	SMD LCD ribbon cable socket	1	J6001
293	3CB1-DF23C16DP	SMD Board-to-board connector	1	J6002
294	6PD7-4002-HL2E	DP770 accessory and channel knob connecting wire board	1	
295	6SS1-4002-HL3C	DP770 accessory board SMD suite	1.1	
296	0SS1-4002-HL3C	DP770 accessory board SMD suite	1	
297	3CB1-DF23C16DS	SMD board-to-board connector	1	U2001
298	6PD7-4002-HL3D	DP770 accessory board	1	
299	0SS5-4002-AA	DP770-02 Hardware Version	1	

## Appendix 2 Material List( Electrics Parts) 136-174MHz

No.	Part No.	Part Name	Quantity	Location
1	6BLS-4814-03327U	SMD button battery (DP770, DM890, PT7800, 219, 620D)	1	BT10
2	2CC1-32-X5R6R3-10 7M	SMD flake multi-layer capacitor	3	C1,C179,C227
3	2CC1-10-X5R100-10 5K	flake multi-layer capacitor	37	C2,C6,C9,C11,C15,C19,C26,C50,C53,C62,C65,C74,C77,C100,C103,C107,C110,C113,C116,C120,C125,C126,C127,C132,C134,C138,C140,C142,C146,C148,C150,C155,C164,C180,C183,C184,C456
4	2CC1-10-C0G500-9R 0C	flake multi-layer capacitor	1	C322
5	2CC1-10-X7R160-10 4K	R flake multi-layer capacitor	68	C3,C7,C16,C27,C35,C42,C43,C44,C54,C56,C58,C60,C66,C68,C70,C71,C78,C80,C82,C91,C93,C106,C133,C136,C137,C141,C147,C149,C161,C167,C168,C169,C170,C177,C186,C190,C200,C214,C219,C224,C229,C230,C242,C251,C252,C253,C254,C264,C266,C276,C283,C289,C291,C295,C296,C297,C312,C328,C330,C331,C336,C337,C338,C347,C348,C353,C355,C431
6	2CC1-10-X7R250-18 3K	R flake multi-layer capacitor	1	C459
7	2CC1-10-C0G500-10 0D	R flake multi-layer capacitor	23	C4,C8,C14,C28,C40,C41,C52,C64,C76,C102,C105,C109,C112,C115,C118,C166,C213,C302,C46,C257,C366,C396,C248
8	2CC1-32-Y5V100-226 Z	flake multi-layer capacitor	5	C5,C20,C29,C182,C218
9	2CC1-16-X7R6R3-10 6K	SMD ceramic capacitor	6	C12,C121,C156,C199,C130,C181
10	2CC1-10-C0G500-16 0J	flake multi-layer capacitor	1	C370
11	2CC1-10-C0G500-10 1J	R flake multi-layer capacitor	50	C13,C17,C21,C23,C30,C33,C51,C55,C57,C59,C61,C63,C67,C69,C72,C73,C75,C79,C81,C101,C104,C108,C111,C114,C117,C119,C131,C135,C139,C165,C178,C191,C2

				10,C211,C212,C437,C245,C284,C334,C335,C341,C342,C343,C344,C345,C349,C350,C362,C86,C403
12	2CT1-TP20-100-100M	R SMD tantalum capacitor	5	C18,C25,C32,C34,C236
13	2CC1-32-X5R100-476K	SMD flake multi-layer capacitor	1	C22
14	2CC1-10-X7R500-102K	R flake multi-layer capacitor	30	C24,C90,C92,C163,C176,C440,C47,C94,C97,C122,C250,C299,C326,C369,C374,C432,C436,C458,C462,C466,C187,C377,C380,C384,C434,C48,C457,C460,C454,C465
15	2CC1-10-X5R6R3-225K	R flake multi-layer capacitor	1	C31
16	2CC1-10-X7R500-103K	R flake multi-layer capacitor	37	C36,C376,C455,C461,C188,C220,C222,C237,C270,C314,C316,C317,C318,C319,C320,C323,C325,C329,C339,C340,C352,C354,C360,C361,C365,C373,C404,C405,C406,C408,C409,C430,C433,C453,C463,C493,C278
17	2CC1-10-C0G500-110J	R flake multi-layer capacitor	2	C37,C217
18	2CC1-16-C0G500-180J	R flake multi-layer capacitor	4	C399,C400,C483,C484,
19	2CC1-10-C0G500-5R0C	R flake multi-layer capacitor	5	C38,C240,C268,C277,C394
20	2CC1-10-C0G500-471J	flake multi-layer capacitor	3	C49,C201,C202
21	2CC1-10-X7R100-224K	R flake multi-layer capacitor	4	C83,C84,C143,C154
22	2CC1-16-X7R500-102K	R flake multi-layer capacitor	4	C85,C472,C476,L8
23	2CC1-10-C0G500-3R0D	flake multi-layer capacitor	1	C233
24	2CC1-10-C0G500-120J	R flake multi-layer capacitor	10	C123,C401,C402,C244,C249,C255,C258,C445,C446,C395
25	2CC1-10-C0G500-470J	R flake multi-layer capacitor	8	C388,C153,C185,C144,C351,C410,C391,C392,



26	2CC1-10-X7R160-33 3K	R flake multi-layer capacitor	2	C151,C152
27	2CC1-10-C0G500-27 1J	flake multi-layer capacitor	8	C157,C158,C159,C160,C439,C263,C451,C452
28	2CC1-10-X7R250-22 3K	R flake multi-layer capacitor	1	C162
29	2CT1-TS32-250-2R2 M	SMD tantalum capacitor	2	C171,C272
30	2CC1-10-C0G500-33 0J	R flake multi-layer capacitor	6	C172,C173,C174,C175,C367,C324
31	2CC1-10-C0G500-3R 0B	flake multi-layer capacitor	1	C275
32	2CC1-10-C0G500-13 0J	R flake multi-layer capacitor	3	C417,C372,C124
33	2CC1-10-C0G500-2R 0D	flake multi-layer capacitor	2	C205,C98
34	2CC1-10-C0G500-2R 5B	R flake multi-layer capacitor	3	C206,C207,C306
35	2CC1-10-C0G500-22 0J	R flake multi-layer capacitor	4	C215,C269,C387,C371
36	2CC1-10-C0G500-7R 0C	flake multi-layer capacitor	4	C398,C414,C386,C382
37	2CT1-TS32-160-100 M	R SMD tantalum capacitor	14	C221,C223,C225,C226,C234,C235,C310,C311,C313,C315,C363,C364,C435,C288
38	2CC1-10-C0G500-15 1J	R flake multi-layer capacitor	14	C228,C231,C256,C259,C260,C261,C262,C267,C292,C293,C294,C300,C301,C305
39	2CC1-16-C0G500-8R 0C	R flake multi-layer capacitor	1	C232
40	2CC1-16-C0G500-5R 0B	flake multi-layer capacitor	3	C239,C45,C246
41	2CC1-16-C0G500-20	R flake multi-layer	2	C241,C247

	0J	capacitor		
42	2CC1-16-C0G500-10 1J	R flake multi-layer capacitor	2	C243,C282
43	2CC1-10-C0G500-8R 0C	flake multi-layer capacitor	1	C393
44	2CT1-TS32-350-R10 M	R SMD tantalum capacitor	1	C271
45	2CT1-TS32-350-R33 M	R SMD tantalum capacitor	1	C273
46	2CC1-16-C0G500-10 0D	R flake multi-layer capacitor	5	C274,C477,C480,C482,C486
47	2CC1-10-C0G500-6R 0C	R flake multi-layer capacitor	1	C99
48	2CC1-16-C0G500-24 0J	R flake multi-layer capacitor	2	C281,C287
49	2CC1-16-C0G500-1R 0B	flake multi-layer capacitor	1	C286
50	2CC1-10-X5R100-47 4K	R flake multi-layer capacitor	1	C290
51	2CC1-10-X7R500-33 2K	R flake multi-layer capacitor	1	C298
52	2CC1-10-C0G500-20 0J	R flake multi-layer capacitor	3	C303,C378,C416
53	2CC1-10-C0G500-56 0J	R flake multi-layer capacitor	6	C304,C438,C321,C327,C389,C390
54	2CC1-10-C0G500-18 1J	R flake multi-layer capacitor	1	C332
55	2CC1-10-C0G500-15 0J	R flake multi-layer capacitor	1	C368
56	2CC1-10-C0G500-12 1J	R flake multi-layer capacitor	1	C379

57	2CC1-10-C0G500-18 0J	R flake multi-layer capacitor	5	C381,C383,C441,C87,C442
58	2LL1-16-R10JB	Laminated inductor	2	L63,L5
59	2CC1-10-X7R160-47 3K	R flake multi-layer capacitor	1	C448
60	2CC1-16-C0G500-47 1J	R flake multi-layer capacitor	1	C449
61	2CC1-10-X7R250-12 3K	R flake multi-layer capacitor	1	C450
62	2CC1-16-Y5V160-105 Z	R flake multi-layer capacitor	1	C464
63	2CC1-16-C0G500-12 0J	R flake multi-layer capacitor	1	C279
64	2CC1-16-C0G500-11 0J	R flake multi-layer capacitor	2	C469,C468,
65	2CC1-16-C0G500-6R 0C	R flake multi-layer capacitor	3	C280,C238,C39
66	2CC1-16-C0G500-43 0J	R flake multi-layer capacitor	1	C471
67	2CC1-16-C0G500-22 0J	R flake multi-layer capacitor	1	C473
68	2RS1-16-470J	R flake resistor	1	C475
69	2CC1-16-C0G500-27 0J	R flake multi-layer capacitor	2	C487,C478
70	2CC1-16-C0G500-68 0J	R flake multi-layer capacitor	1	C479
71	2CC1-16-C0G500-9R 0C	R flake multi-layer capacitor	1	C285
72	2CC1-16-C0G500-15 0J	R flake multi-layer capacitor	1	C481
73	1DZ1-PESD5V0S1UB	SMD voltage regulated	1	D1

		diode DP770, DP780, STP,KH620		
74	1DZ1-PESD12VS1UB	SMD voltage regulated diode	1	D2
75	1DR1-1SR154-400	R SMD commutation diode	1	D3
76	1DS1-DAN222	R SMD switch diode	1	D4
77	1DS1-DA2S10100L	R SMD switch diode	10	D10,D11,D12,D13,D21,D25,D31,D50,D36,D37
78	1DR1-BAT54C	SMD Schottky diode;	1	D17
79	1DS1-HSC277	R SMD switch diode (production halt)	1	D30
80	1DV1-1SV325	R SMD varactor 7200, 568,4208,8200,4200-4,5 200V, 7808	9	D51,D62,D63,D64,D65,D38,D39,D40,D41
81	1DV1-1SV305	R SMD varactor	6	D32,D33,D34,D35,D52,
82	1DV1-1SV278	R SMD varactor	1	D42
83	1DS1-RB706F-40	R SMD switch diode	1	D61
84	1DS1-HVC131	R SMD switch diode (production halt)	4	D70,D71,D72,D73
85	3FW1-42932-302320	R SMD fuse	1	F1
86	5FE1-BLM21P300S	R SMD EMI suppression filter	6	FB1,FB2,FB3,FB5,FB91,L75
87	5FE1-BLM18PG181S N1	SMD EMI suppression filter	24	FB4,FB8,FB9,FB10,FB11,FB12,FB13,FB14,FB15,FB20,FB21,FB22,FB30,FB31,FB32,FB33,FB34,FB40,FB41,FB42,FB45,FB50,FB60,FB70
88	5FE1-BLM15BB121S N1	SMD EMI suppression filter	2	FB16,FB17
89	5FE1-BLM11A601S	R SMD EMI suppression filter	6	FB18,FB80,FB81,FB82,FB90,L74
90	5FE1-BLM21PG221S N1	SMD EMI suppression filter	1	FB71
91	7MHP-4002-01A-W	TD7700 battery	1	J1

		connector		
92	3CM1-TFC-008-J	Flap TF clutch base	1	J10
93	3CB1-DF23C-50DS	SMD board-to-board connector DP770 DP780	1	J20
94	3CC1-USB-UH51543-CS7	USB port AB-type socket	1	J22
95	2LL1-30-VLS3012T100M	Laminated inductance	4	L1,L2,L3,L4
96	2LW1-16UC-R33G	SMD coil inductance	8	L20,L21,L25,L28,L29,L33,L69,L67
97	2RS1-16-000O	R flake resistor	3	L65,L66,R268
98	2LW1-16UC-390G	SMD coil inductance	2	L9,L52
99	2LL1-16-3N9S	R laminated inductance	2	L15,L16
100	2LW1-16UC-102J	SMD coil inductance	3	L22,L30,L64
101	2LW1-20UC-560GB	SMD coil inductance	2	L23,L31
102	2LW1-20UC-470GA	R SMD coil inductance	1	L32
103	2LW1-32UC-390J	R SMD coil inductance	1	L24
104	2LW1-16UC-180G	SMD coil inductance	1	L26
105	2LW1-16UC-270G	SMD coil inductance	4	L27,L73,L87,L56
106	2LW1-20UC-331J	SMD coil inductance	1	L40
107	2LW1-25UC-103J	R SMD coil inductance	2	L41,L42
108	2LL1-16-3R3K	R laminated inductance	1	L43
109	2LW1-25UC-332K	SMD coil inductance	1	L44
110	2LW1-16UC-560G	SMD coil inductance	1	L50
111	2LW1-16UC-680G	SMD coil inductance	4	L51,L71,L59,L72
112	2LW1-16UC-181J	SMD coil inductance	1	L54
113	2LW1-16UC-330G	SMD coil inductance	2	L57,L53
114	2LW1-20UC-270G	R SMD coil inductance	4	L58,L60,L62,L61
115	2RS1-16-331J	R flake resistor	2	L68,R425
116	2LW1-25UC-102JA	R SMD coil inductance	1	L76
117	2LH1-R401R5-L08-05	R SMD air-core	2	L77,L84

		inductance		
118	2LW1-20UC-102J	SMD coil inductance	1	L78
119	2LH1-R401R2-L03-05	SMD air-core inductance	1	L79
120	2LH1-R301R0-L04-05	R SMD air-core inductance	1	L80
121	2LH1-R301R2-L05-05	R SMD air-core inductance	1	L81
122	2LH1-R301R0-L07-05	R SMD air-core inductance	1	L82
123	2LH1-R401R5-L07-05	R SMD air-core loop	1	L83
124	2LH1-R301R0-L08-05	R SMD air-core inductance	1	L85
125	2RS1-20-103J	Flake resistor	1	L86
126	4PE1-06-F2	SMD LED	1	LED10
127	1TF1-ST2301	R SMD FET	5	Q1,Q5,Q12,Q20,Q21
128	1TF1-2SK1824	R SMD FET (production halt)	2	Q2,Q15
129	1TT1-DTC144EE	R SMD triode	8	Q3,Q8,Q11,Q13,Q14,Q30,Q52,Q71
130	1TT1-MMBT3904	SMD triode	3	Q4,Q6,Q7
131	1TT1-2SC5006	SMD triode (production halt)	5	Q9,Q51,Q61,Q63,Q64
132	1TT1-FMMT717TA	R SMD triode	2	Q40,Q70
133	1TT1-2SC4617-R	R SMD triode	3	Q41,Q42,Q50
134	1TT1-2SC3356-R24	R SMD triode (production halt)	3	Q43,Q44,Q72
135	1TT1-2SC5108-Y	R SMD triode	1	Q60
136	1TT1-AT41511	Low noise NPN triode	1	Q62
137	1TT1-2SC3357	R SMD FET (production halt)	1	Q73
138	1TF1-RD07MUS2B	E R SMD FET (S	1	Q74

		series/6500/7200/567/D P770/780/STP/560/AP57		
139	1TF1-RD01MUS2	E R SMD FET portable digital and analogue material	1	Q75
140	2RS1-10-101J	R flake resistor	21	R1,R51,R53,R116,R120,R141,R142,R216,R250,R285,R286,R287,R294,R296,R303,R309,R340,R350,R83,R84,R361
141	2RS1-10-474J	R flake resistor	2	R2,R177
142	2RS1-10-202J	R flake resistor	3	R3,R262,R334
143	2RS1-10-514J	flake resistor	1	R4
144	2RS1-10-103J	R flake resistor	71	C346,R5,R36,R37,R38,R49,R50,R73,R220,R222,R17,R20,R21,R22,R25,R26,R27,R28,R29,R30,R31,R32,R35,R74,R75,R78,R91,R92,R94,R95,R96,R98,R101,R156,R157,R158,R159,R160,R161,R197,R201,R209,R214,R215,R217,R221,R240,R241,R242,R243,R245,R248,R249,R392,R260,R15,R64,R276,R281,R282,R283,R284,R298,R313,R316,R336,R345,R346,R362,R431,R290
145	2RS1-10-104J	R flake resistor	14	R6,R147,R185,R191,R212,R225,R231,R172,R230,R314,R317,R318,R341,R391
146	2RS1-10-154J	R flake resistor	5	R7,R79,R169,R194,R211
147	2RS1-10-100J	R flake resistor	3	R8,R203,R210
148	2RS1-10-473J	R flake resistor	6	R10,R12,R151,R152,R155,R322
149	2RS1-10-102J	R flake resistor	15	R11,R149,R76,R326,R328,R338,R339,R347,R420,R235,R234,R246,R213,R224,R227
150	2RS1-10-332J	R flake resistor	2	R14,R373
151	2RS1-10-000O	R flake resistor	18	R16,R33,R34,R39,R71,R168,R171,R181,R199,R204,R289,R293,R304,R320,R321,R324,R337,R380
152	2RS1-10-472J	R flake resistor	6	R18,R19,R175,R178,R263,R280
153	2RS1-10-330J	R flake resistor	45	R23,R24,R42,R43,R55,R57,R58,R59,R60,R61,R62,R63,R67,R68,R77,R115,R117,R118,R119,R121,R122,R125,R126,R127,R128,R129,R131,R132,R133,R134,R135,R136,R137,R138,R182,R183,R187,R188,R200,R202,R205,R208,R218,R219,R267
154	2RS1-10-220J	R flake resistor	20	R40,R41,R44,R45,R46,R47,R48,R54,R162,R163,R164,R165,R166,R167,R244,R86,R342,R343,R344,R393
155	2RS1-10-123J	R flake resistor	2	R65,R323

156	2RE1-10-1501	SMD precision resistor	3	R66,R82,R406
157	2RE1-10-1002	SMD precision resistor	3	R69,R310,R311
158	2RE1-10-49R9-D	SMD precision resistor	1	R80
159	2RS1-10-301J	R flake resistor	2	R358,R359
160	2RS1-10-180J	R flake resistor	1	R356
161	2RS1-10-243J	R flake resistor	2	R88,R325
162	2RS1-10-561J	R flake resistor	2	R89,R369
163	2RS1-16-103J	R flake resistor	1	R97
164	5FE1-BLM15AG221S N1D	EMI suppression filter	12	R103,R104,R105,R106,R107,R108,R109,R110,R111,R112,R113,R114
165	2RS1-10-681J	R flake resistor	3	R124,R139,R415
166	2RS1-10-153J	R flake resistor	2	R140,R192
167	2RE1-10-4702	SMD precision resistor	2	R150,R153
168	2RS1-10-105J	R flake resistor	2	R173,R184
169	2RS1-10-273J	R flake resistor	2	R174,R193
170	2RS1-10-222J	R flake resistor	4	R176,R179,R190,R417
171	2RS1-10-183J	R flake resistor	1	R180
172	2RS1-10-331J	R flake resistor	5	R186,R198,R378,R394,R395
173	2RS1-10-271J	R flake resistor	2	R189,R408
174	2RE1-10-2003	SMD precision resistor	1	R195
175	2RE1-10-2002	SMD precision resistor	4	R196,R421,R312,R123
176	2RE1-10-1003	SMD precision resistor	2	R206,R207
177	2RS1-10-302J	R flake resistor	1	R226
178	2RS1-10-562J	R flake resistor	5	R266,R370,R374,R397,R291
179	2RS1-10-392J	R flake resistor	2	R269,R295
180	2RS1-10-680J	R flake resistor	2	R270,R85
181	2RS1-10-121J	R flake resistor	3	R275,R292,R307
182	2RS1-10-6R8J	flake resistor	4	R277,R278,R279,R305
183	2RS1-10-470J	R flake resistor	4	R288,R351,R427,R70
184	2RS1-10-122J	R flake resistor	1	R299



185	2RE1-10-3302	SMD precision resistor	1	R428
186	2RS1-10-822J	R flake resistor	3	R319,R375,R364
187	2RS1-10-511J	R flake resistor	1	R332
188	2RS1-10-203J	R flake resistor	2	R335,R379
189	2RS1-10-124J	R flake resistor	2	R353,R376
190	2RS1-10-184J	R flake resistor	1	R360
191	2RE1-10-2203	SMD precision resistor	8	R363,R365,R367,R368,R396,R402,R409,R412
192	2RS1-10-683J	R flake resistor	1	R354
193	2RS1-10-510J	flake resistor	2	R372,R430
194	2RS1-10-151J	R flake resistor	1	R377
195	2RS1-10-471J	R flake resistor	1	R390
196	2RS1-32-R39J	R flake resistor	3	R398,R399,R400
197	2RS1-10-225J	flake resistor	2	R401,R403
198	2RS1-16-330J	R flake resistor	1	R416
199	2RS1-10-823J	R flake resistor	2	R418,R429
200	2RS1-10-363J	R flake resistor	1	R419
201	2RS1-10-393J	R flake resistor	1	R423
202	2RS1-16-271J	R flake resistor	1	R424
203	2RT1-NTH5G16P40B 333J	SMD thermistor	1	R432
204	1IS1-TPS62110	Power chip	1	U1
205	1IS1-TPS65023	Power management chip DP770, DP780, KH620D,STR,STP	1	U2
206	1IS1-ADS1015	AD convertor IC	1	U52
207	1IS1-XC6228D122VR	SMD specialized IC SPURAL FP520 FM540	1	U6
208	5OT1-12R8-ACL4-32 25	SMD temperature compensated crystal oscillator	1	U75

209	5XC1-19R2-TKL3056 B	SMD crystal oscillator DP770 STP KH620	1	U11
210	1IP1-OMAPL138BZW T3	Dual core CPU	1	U30
211	1IM1-MT47H64M16	SMD memorizer IC	1	U41
212	1IS1-TC75W51FU	R SMD specialized IC	1	U50
213	1IS1-TLV320AIC14K	CODEC chip	1	U51
214	1IL1-TDA8547TS	E general linear IC	1	U53
215	1ID1-MXD2020ML	SMD general logic IC (accelerated sensor)	1	U62
216	1IS1-XC6209B552MR	SMD voltage regulated IC	1	U70
217	1IS1-XC6204B502MR	R SMD voltage regulated IC	1	U100
218	1IS1-XC6204B302MR	SMD voltage regulated IC	1	U90
219	1IS1-XC6204B332MR	SMD voltage regulated IC	2	U60,U72
220	1IS1-SKY72310	PLL chip	1	U74
221	1IS1-TLV5614	DA convertor chip	1	U79
222	1TC1-UMC4	R SMD multiunit tube	5	U4,U71,U73,U78,U110
223	1IS1-MC74VHC1GT6 6	High-speed CMOS simulated switch IC	2	U76,U77
224	1IS1-AD9864	IF digital system	1	U91
225	1IL1-NJM2904V	R SMD linear IC	2	U80,U111
226	5XC1-32R8-FC-135	SMD crystal oscillator STP-U,DP770V	1	X10
227	1IS1-ADE1L	SMD frequency mixer	1	Z10
228	5FC1-DSF51R6M-07 05	R SMD crystal filter, PT568/78/72/62/65/68/D R55/DM58/3208/V68/E6	1	Z11

		6		
229	7MHC-4002-02A-W	DP770 shield cover bracket 1	1	S1
230	7MHC-4002-04A-W	DP770 shield cover bracket 2	1	S2
231	7MHC-4002-16A-W1	GPS shield cover base 1	1	S3
232	6PM7-4070-HMC	DP770-01mainboard PCB	1	
233	7PLJ-025006-T01A	High temperature sticker SEPURA DMR bar code sticker	1.05	

## Appendix 3 Material List (Structural Section)

No.	Part Number	Part Name	Quantity
1	7WFP-4002-01A	DP770 lens protection film PET; transparent	1
2	7MHP-4002-02A-WC	DP770 LCD lens PC+PMMA, transparent	1
3	7GCJ-S4002-J	DP770lens double-sided tape NITTO 57120B	1
4	7MHP-4002-04A-W9	DP770 PTT cover plate PC+ABS/TPU; black/PT2757C	1
5	7MHR-4002-10A-W6	DP770 side silica gel key silica gel; blue,PT654C;	1
6	7SAF-020070M-SZYB-Z1	2.0X7.0 cross machine screw with iron hardened; black-zinc-plated	2
7	7MHP-4002-01A-W0	DP770 main unit front shell PC+ABS, black	1
8	6SS1-4002-HL3C	Accessory board SMD material	1
9	7MHM-4002-01A-W9	DP770 LCD sponge adhesive; black	1
10	7GCB-S4002-01A	DP770 speaker dust-proof net; black	1
11	7MHR-4002-16A-W9	DP770 knob waterproof gasket silica gel; black	1
12	4SS7-3525-016-100A	DP770 speaker (waterproof ) $\Phi=35\text{mm}$ , $H=25\text{mm}$ , $16\Omega$ , $1W$	1
13	4SM7-4002-A40	Waterproof mic with case $\Phi 7.0\text{mm}$ , height 2.8mm,	1

14	4SM7-4002-A40	Channel switch RE11	1
15	7MHR-4002-09A-W9	DP770 digital key silica gel; PT432C	1
16	7MHS-4002-01A-W	DP770 LCD bracket	1
17	7MHC-4002-11A-W	DP770 display shielding cover 44.3*34.1*2.0MM,copper-nickel	1
18	4PC7-4002H-A	LCD screen ZYW-T18CP-20PJ-B	1
19	7MHS-4002-03A-W	Digital key METAL DOME diameter is 4.0;SUS301	1
20	6PM7-4002-HKG	DP770KEY-LCD PCB board four-layer board	1
21	7SMF-020040M-SZYB-N	M2*4 cross machine screw with iron hardened	7
22	7GCM-180090015-J	DP770 mainboard double-sided adhesive foam18*9*1.5	1
23	7GCM-100090015-J	LCD socket double-sided adhesive foam 10*9*1.5	2
24	7SMF-026060M-SZHT-B1	M2.6*6 cross machine with iron hardened, black-zinc machine	2
25	6SS3-BJ4026-A	KBJ-15belt clip PC+ABS	1
26	7MHR-4002-11A-W9	DP770 main water-proof ring silica gel; black	1
27	7MHP-4002-06A-W9A	DP770 battery top shell PC+ABS; black	1
28	7MHM-4002-02-W	Aluminum shell Poron Poron 36.5*2.5*1.0	1
29	7SAF-020110M-SZYB-Z1	2.0X11.0 cross machine screw 5.3 hardened iron; black-zinc-plated	2
30	7MHR-4002-19A-W9	DP770 screw water-proof ring rubber; black; polished	4
31	7GCB-070045005-J	Radio $\Phi$ 7 speaker cloth water-proof film	2
32	7MHP-4002-05A-W9	DP770 main unit top cover PC+ABS; black	1
33	6PD7-4002-DPD1	DP770 battery charging PCB double board	1
34	7MHS-4002-06-N	DP770 battery latch spring steel; nickel-plated	2
35	7MHP-4002-08A-W9A	DP770 open latch PC+ABS/stainless steel; black	1
36	7MHL-4002-01-W	DP770 aluminum shell ADC12;	1
37	7MHR-7042-06B-W0	Silica gel of thermally conductive silica gel gasket; black ,3*6*9mm,	1
38	3CR7-SMA-50JF-4	RF coaxial connector SMA-J, flange plate installation	1
39	7MHR-4002-15A-W9	DP770 antenna water-proof gasket silica gel; black	1
40	4MV3-KFF081522	$\phi$ 8 DC vibrating motor KFF081522,	1
41	7MHR-4002-17A-W9	DP770 silica gel of motor silica gel gasket; black;	1
42	7MHS-4002-02A-W	DP770 motor presser stainless steel; original color; pb-free	1
43	6BPM-933948-074200-B	li-polymer battery7.4V,2100mAh	1

44	7MHP-4002-07A-W9	DP770 battery bottom cover PC+ABS; black	1
45	7MHR-4002-18A-W9	DP770 discharging base silica gel; black	1
46	7MHP-4002-01A-W	TD7700 battery connector BC-2P-41PH-6.8H	1
47	7MHC-4002-02A-W	DP770 shielding cover bracket 1; 43.4*32.3mm; copper-nickel	1
48	7MBM-S4002-A	Conductive foam 12*7*7; with double-sided adhesive	3
49	7MHC-4002-16A-W1	GPS shielding cover base 1; copper-nickel; pb-free	1
50	7MHC-4002-04A-W	DP770 shielding cover bracket 2; 22.8*15.6mm; copper-nickel	1
51	6PM7-4002-HMH	DP770-02 mainboard PCB ten-layer board	1
52	7SMF-020050M-MHHT-N1	M2*5 torx machine screw with iron hardened, nickel-plated	10
53	6PD7-4002-HPC	DP770 PTT board PCB double-sided board	1
54	7MHS-4002-04A-W	DP770 PTT key METAL DOME4.0;SUS301	1
55	7MHS-4002-05A-W	DP770 socket presser stainless steel, 0.6mm,	1
56	7MDZ-1737-04A-J5	KB-58L sticker 1 barley paper, 8*35*0.2	1
57	6SS1-4002-HL1G	Main flex cable board	1
58	7MHC-4002-05A-W	DP770 shielding cover 2; 23.3*16.1mm; copper-nickel	1
59	7MHC-4002-17A-W1	GPS shielding cover 1 ; copper-nickel; pb-free	1
60	7MHC-4002-03A-W	DP770 shielding cover 1 ;43.9*32.8mm; copper-nickel	1
61	7MHJ-4002-01A-W	GPS shielding cover conductive cloth; 46.85x32.25x0.15mm	1
62	8ATX-400470-WC	DP770 antenna 400-470MHZGPS	1
63	7MHP-4002-03A-W9	DP770 knob PC+ABS/TPU, grey	1
64	7MHS-1767-02B-W	PT6800 knob circlip stainless steel SUS304-1/2H, hardened	1
65	7NRC-077107040-Z	R 7200 channel switch nut brass; black-zinc-plated	1
66	7MHR-4002-13A-WC	DP770 guide beam silica gel; transparent	1
67	7NRC-090110025-W1	Antenna nut	1
68	7MHR-4002-12A-W3	DP770 emergency key silica gel; orange, PT021C	1

# Appendix Figure 1 DP770 UHF Main Board Top Side PCB View

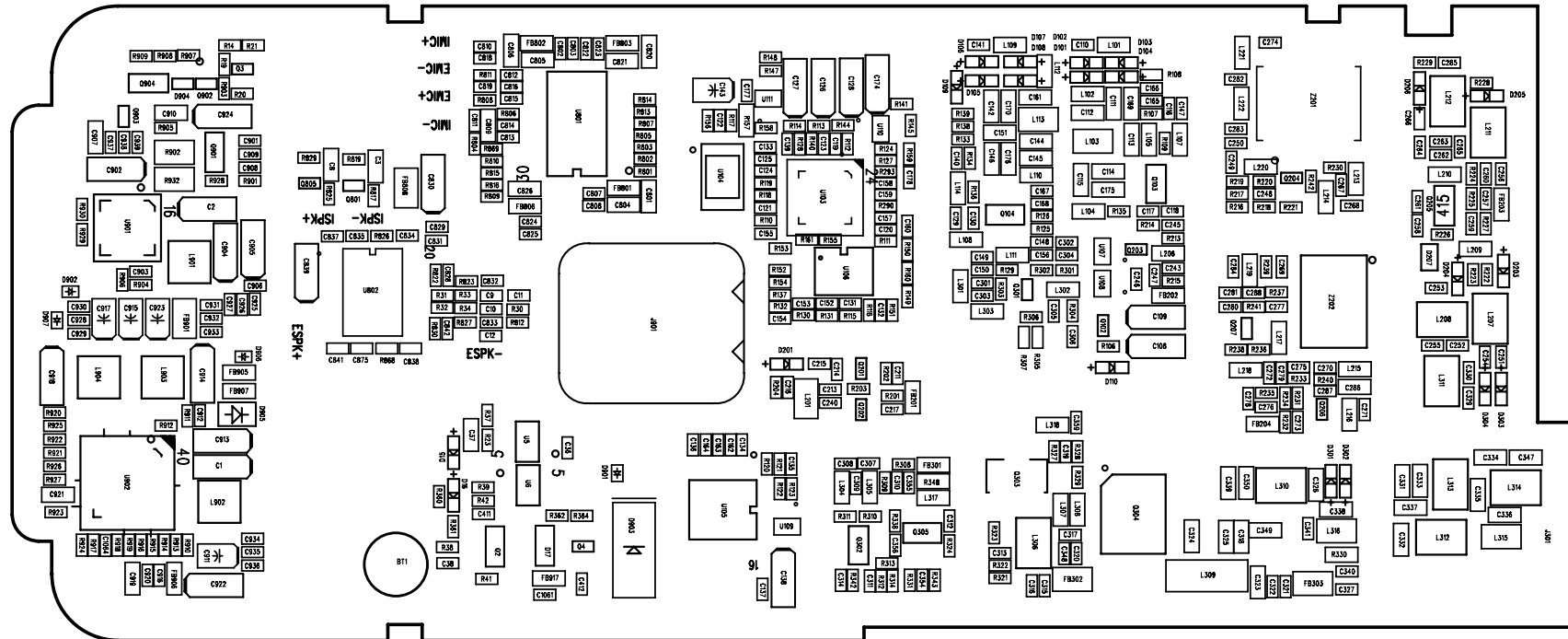



# Appendix Figure 3 DP770 UHF Keypad Top Side PCB View

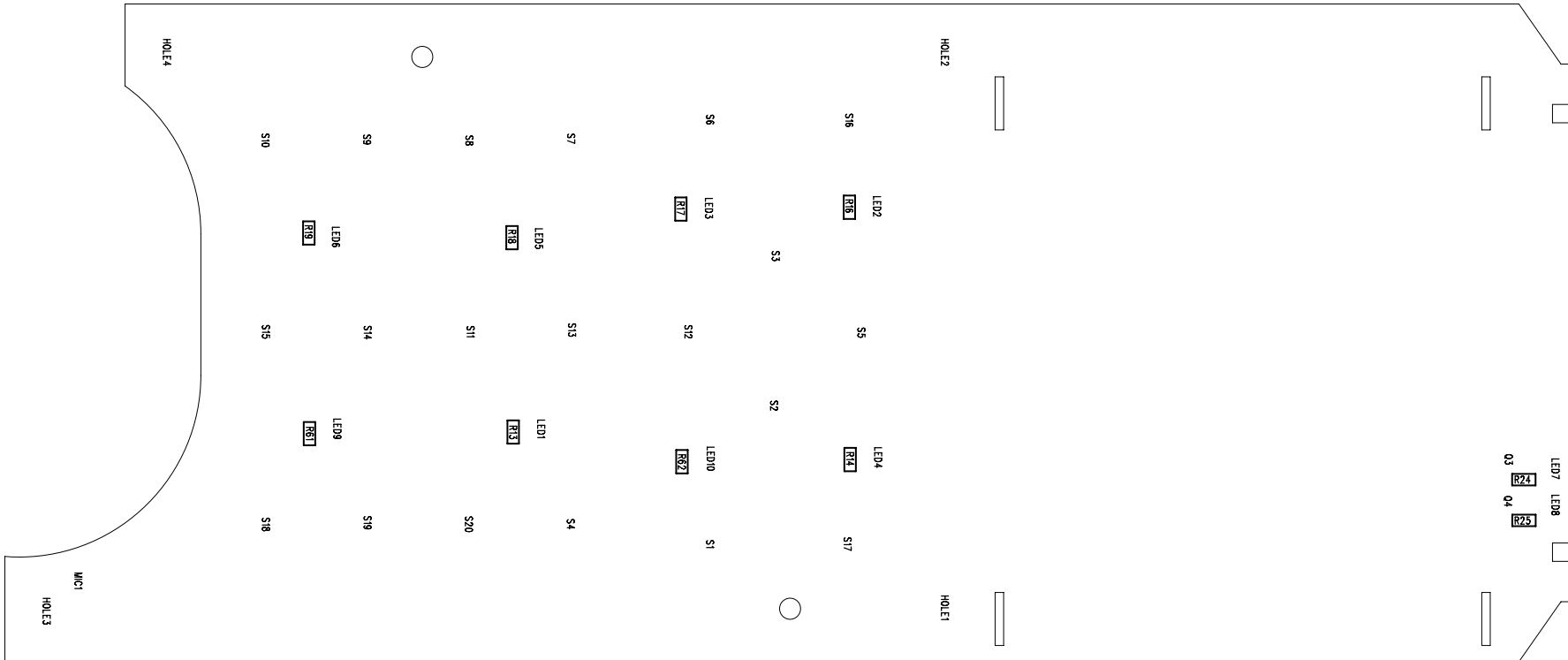



# Appendix Figure 4 DP770 UHF Keypad Bottom Side PCB View

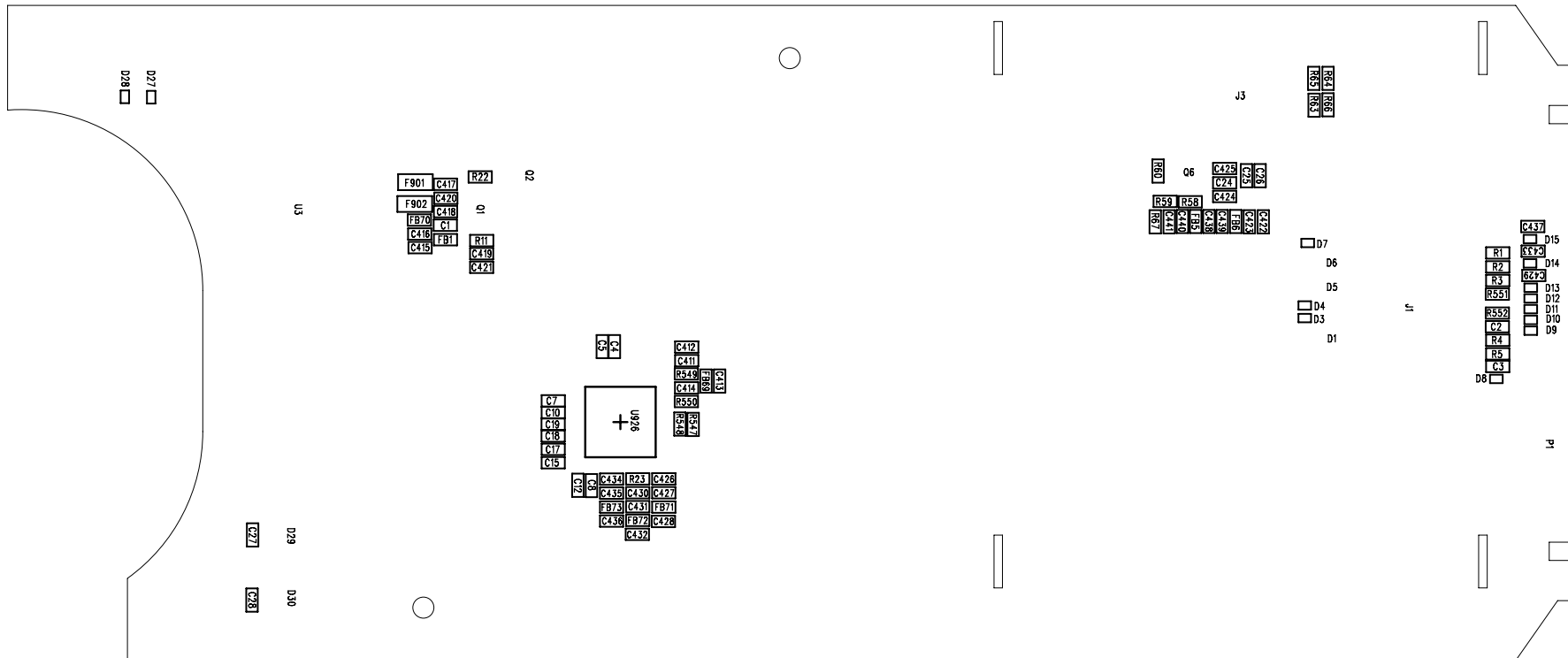

# Appendix Figure 5 DP770 UHF Main Board Schematic Diagram

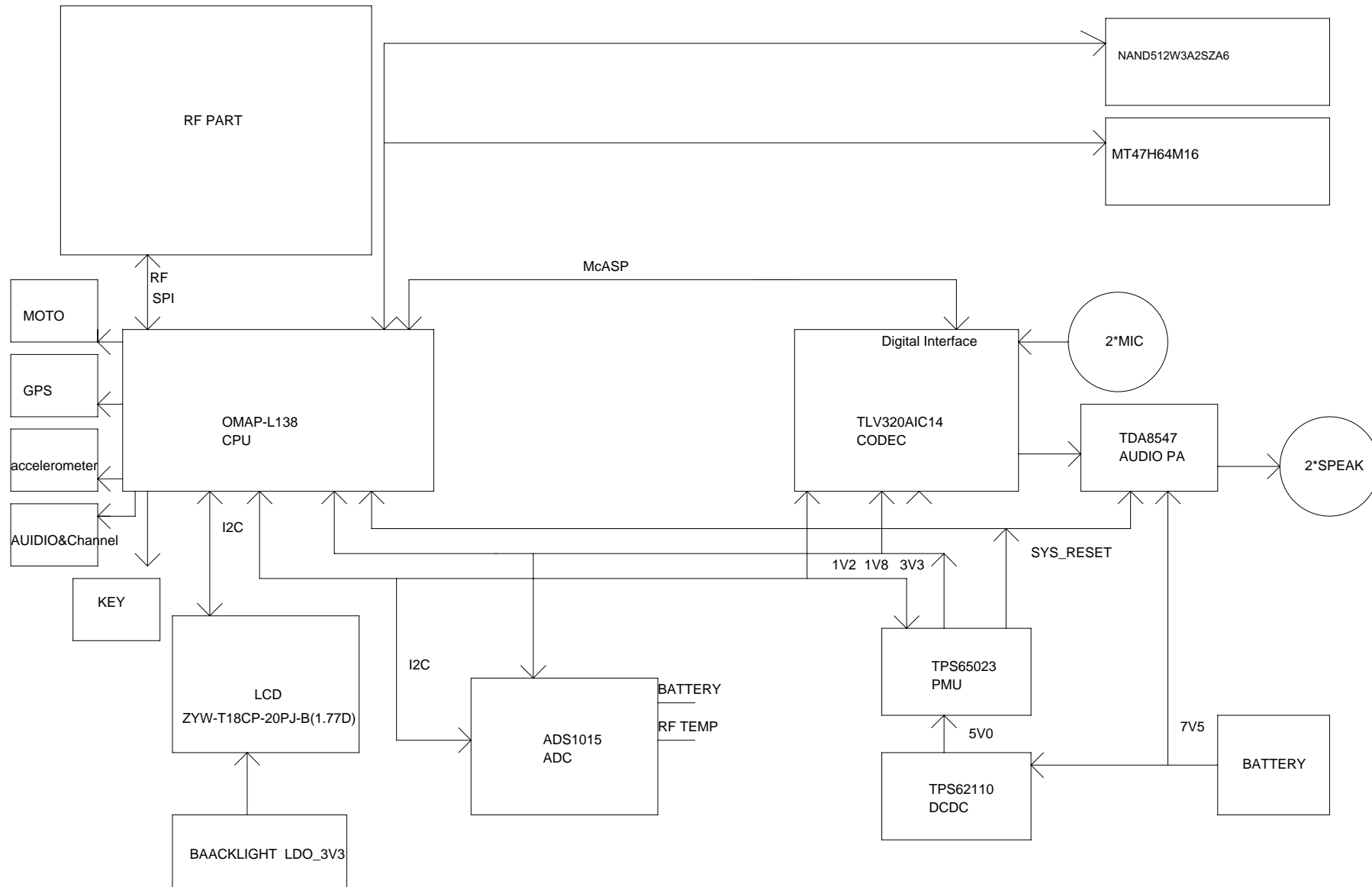

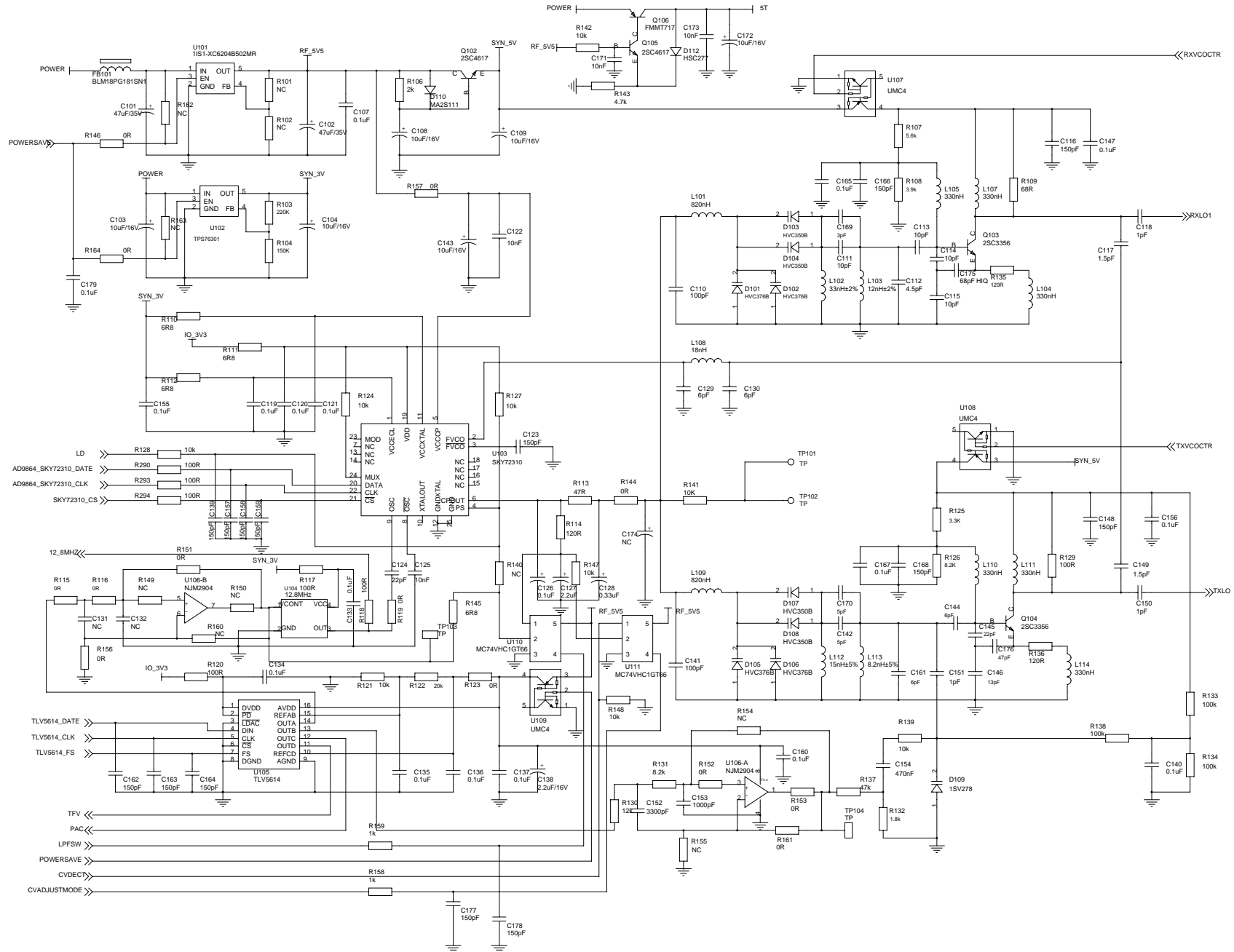

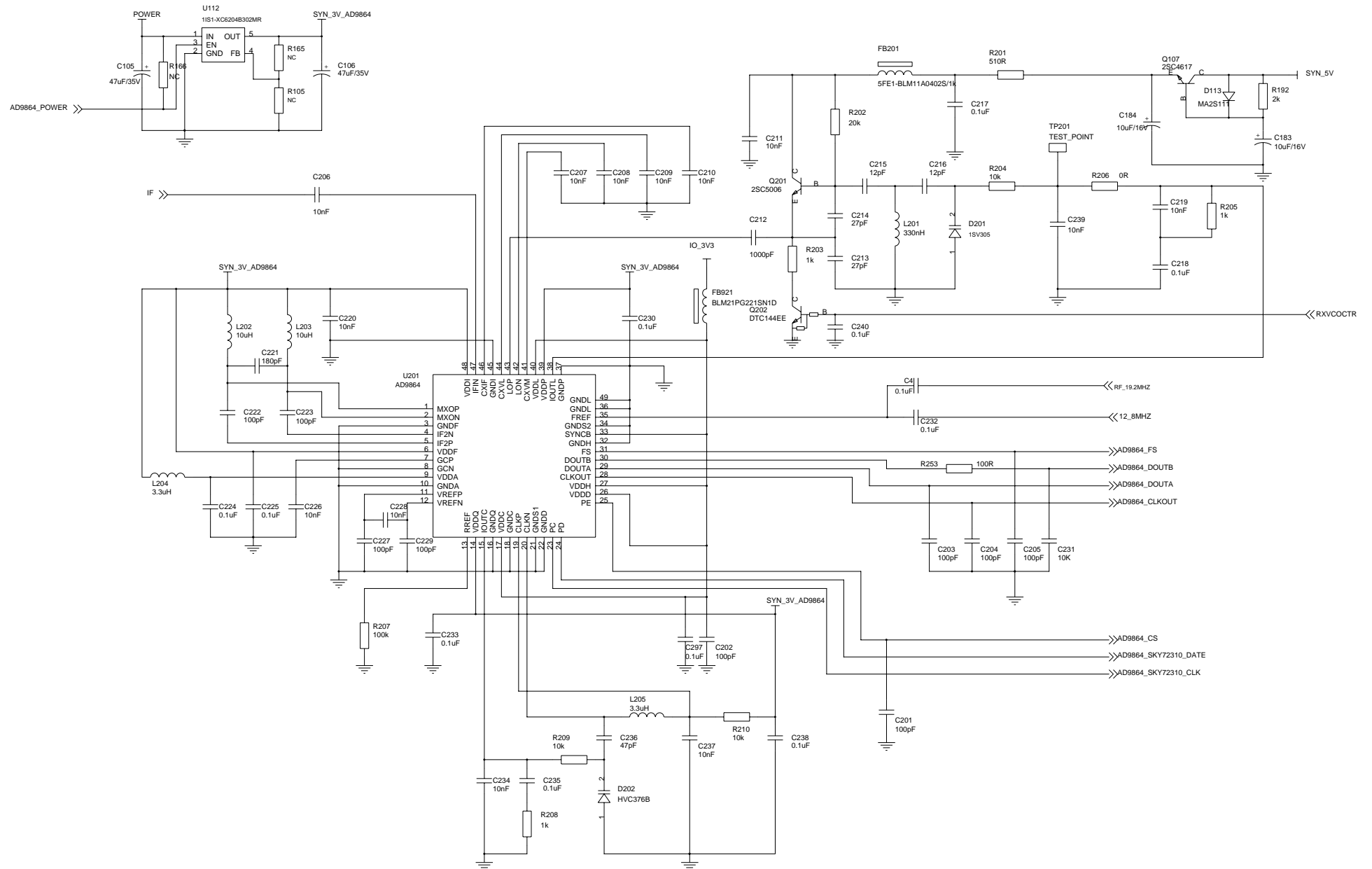

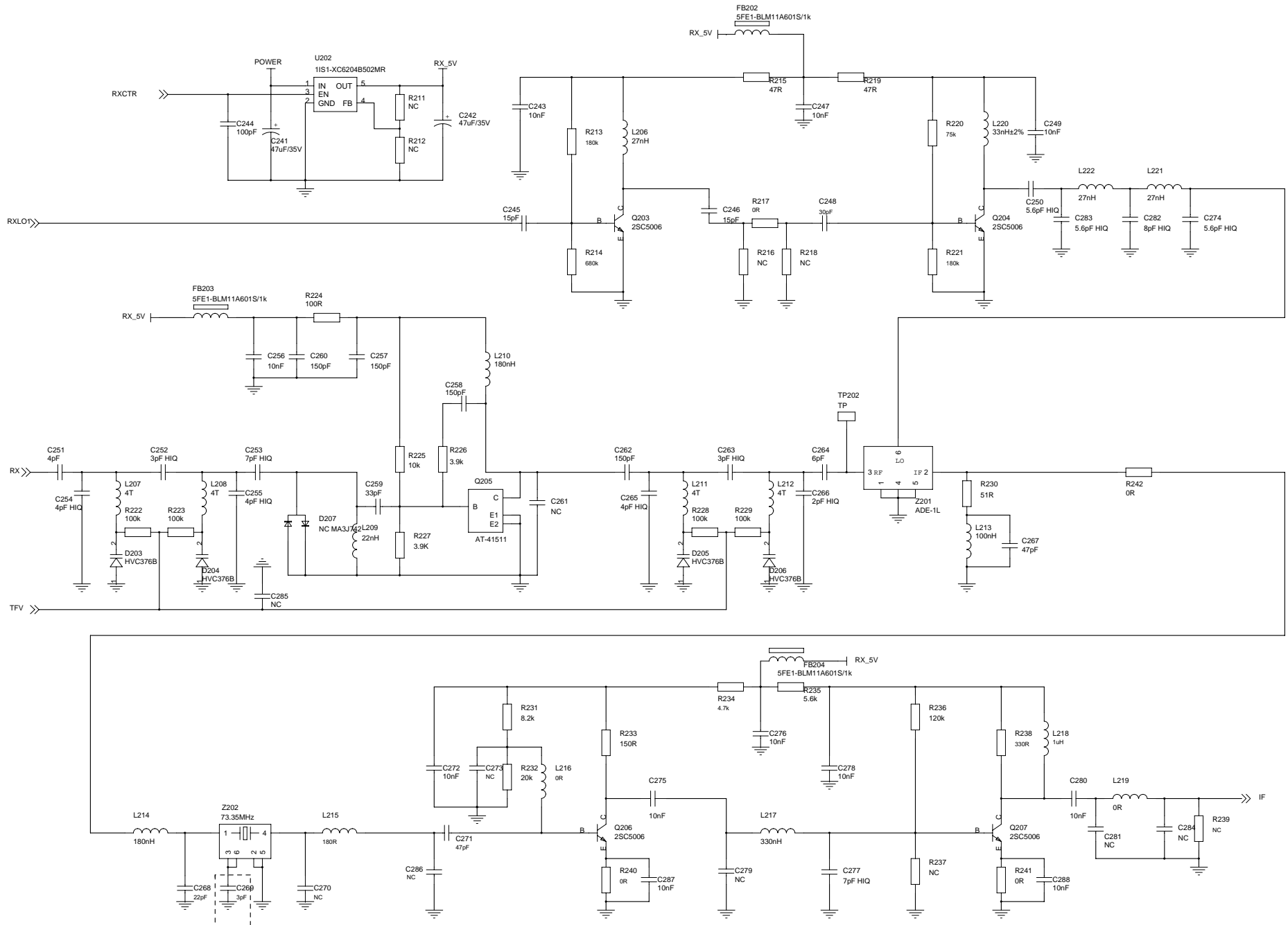

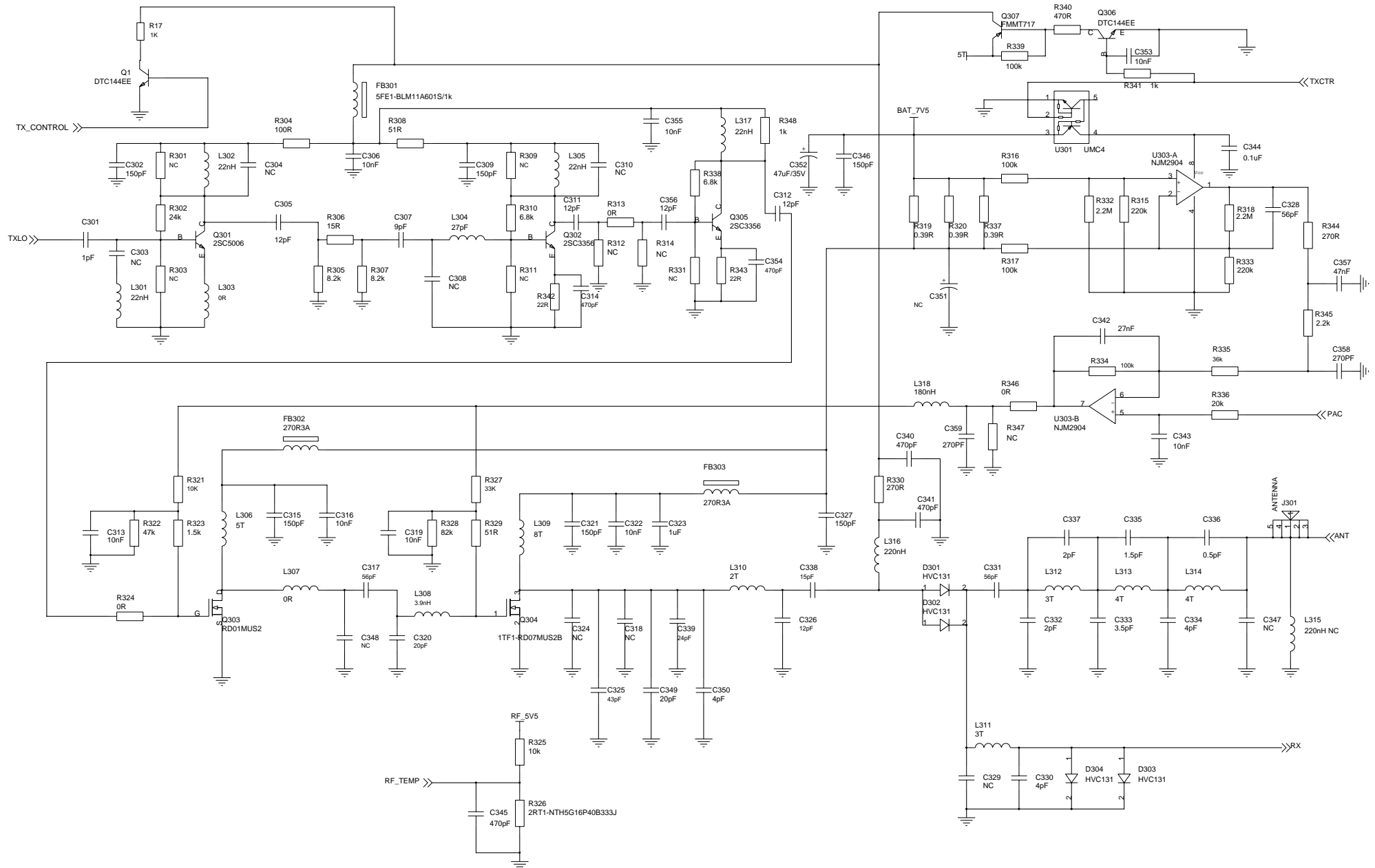

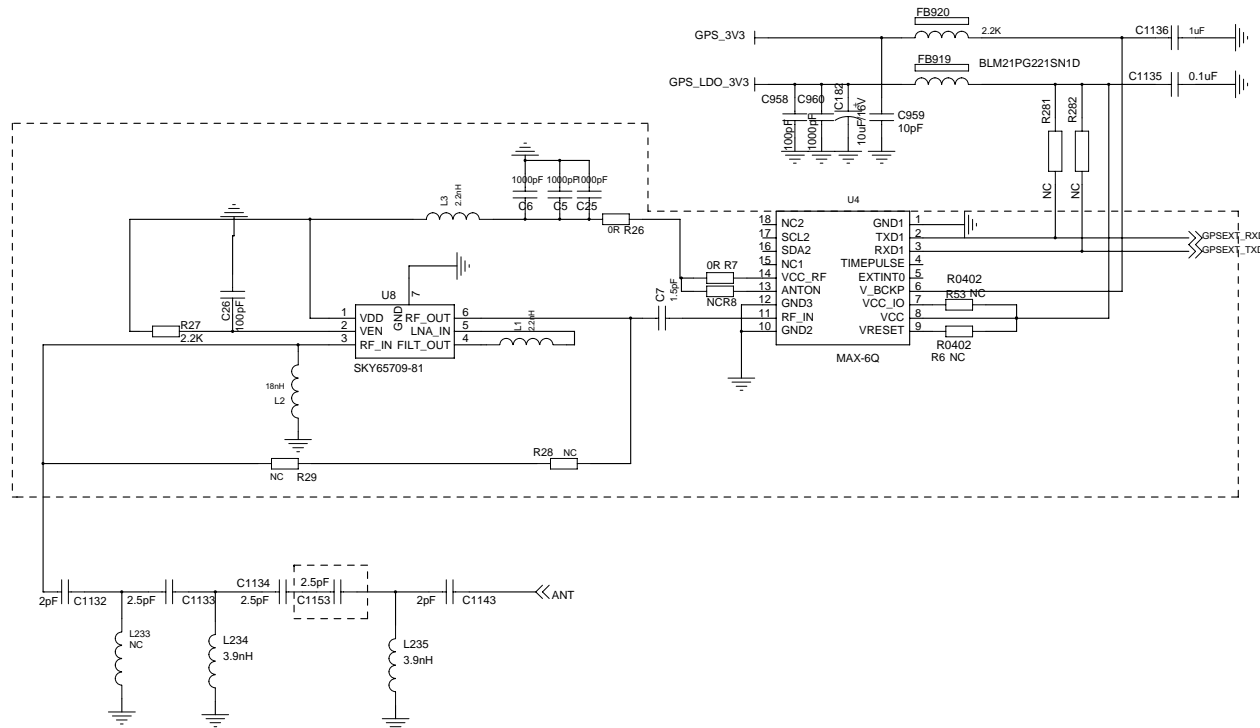
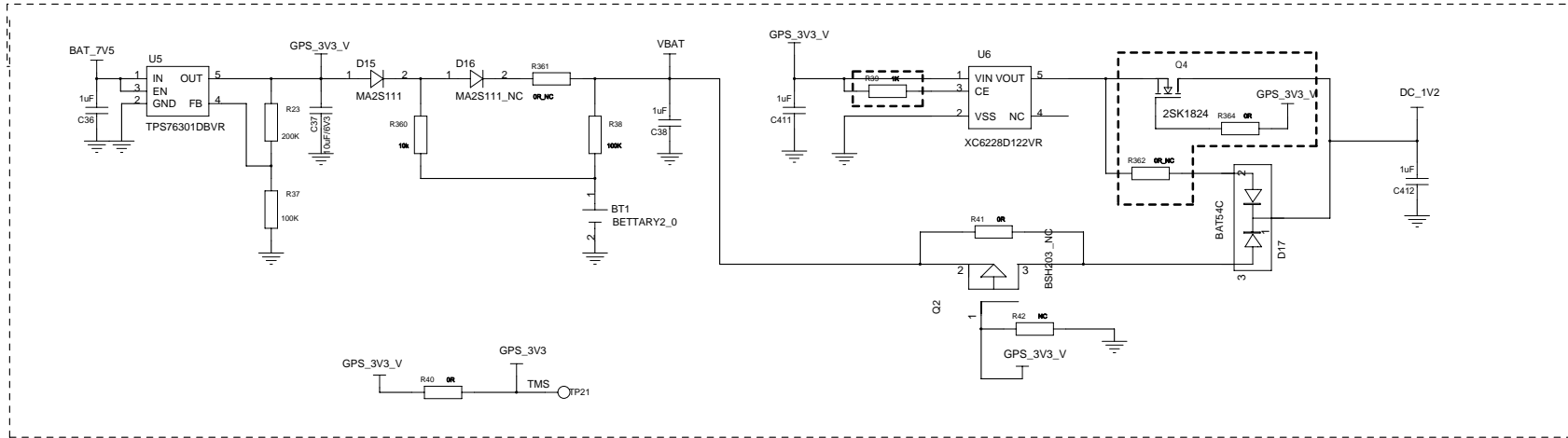





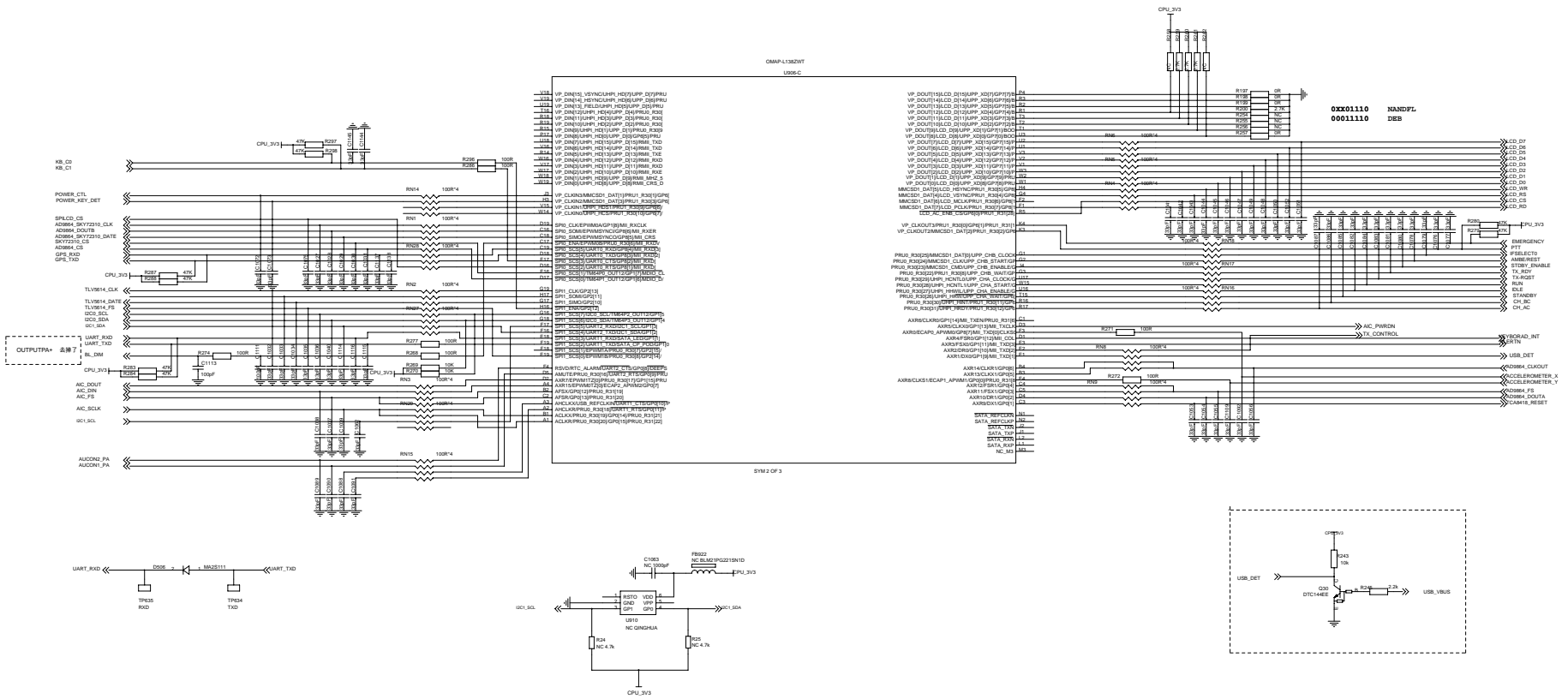

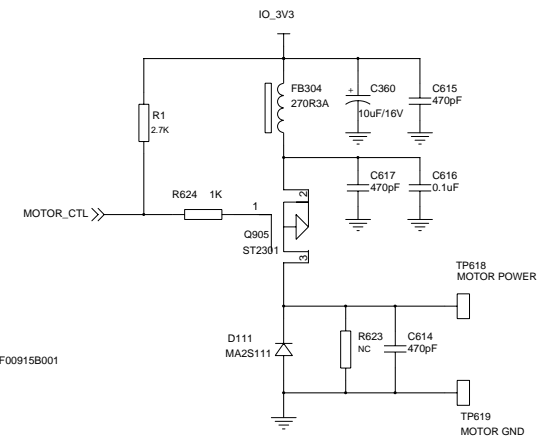
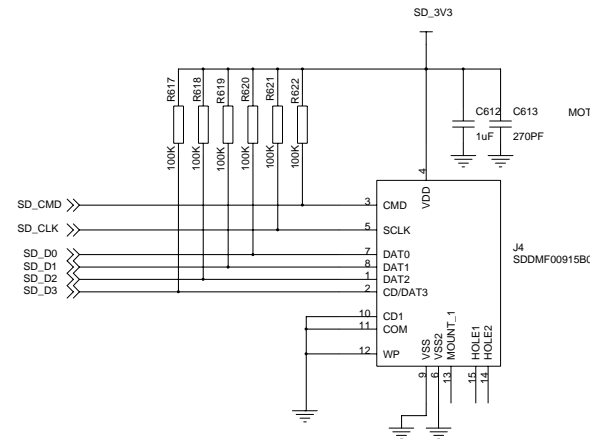
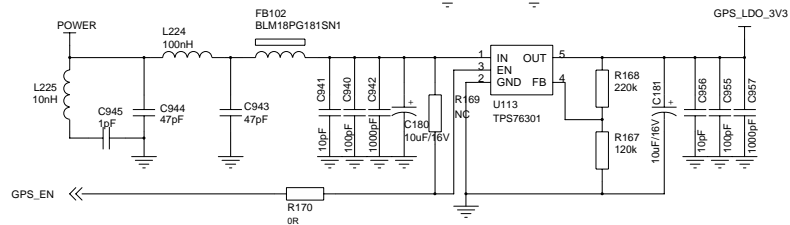
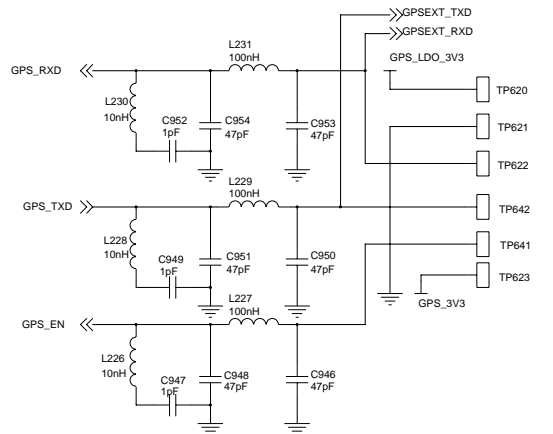
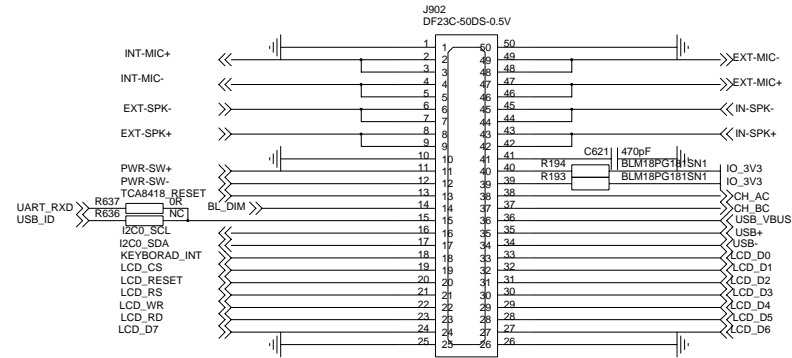
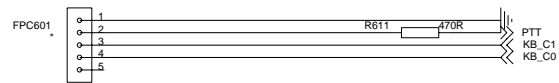

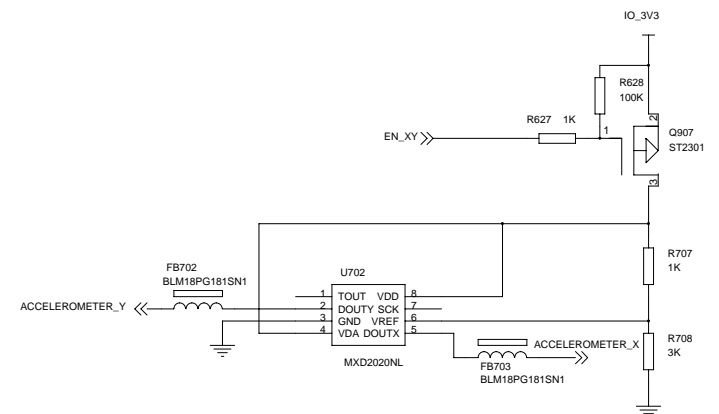
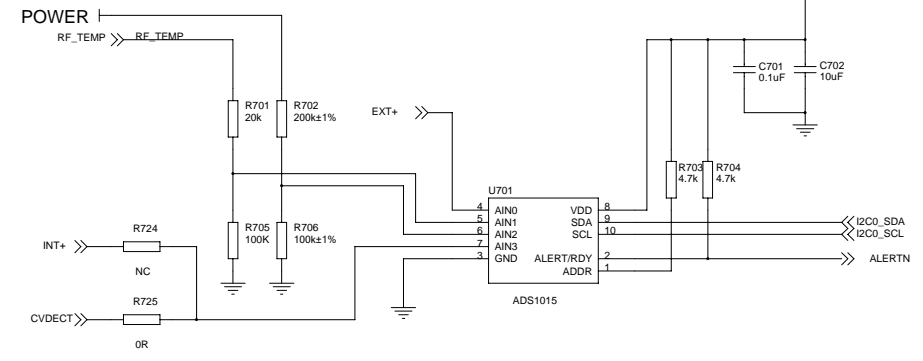
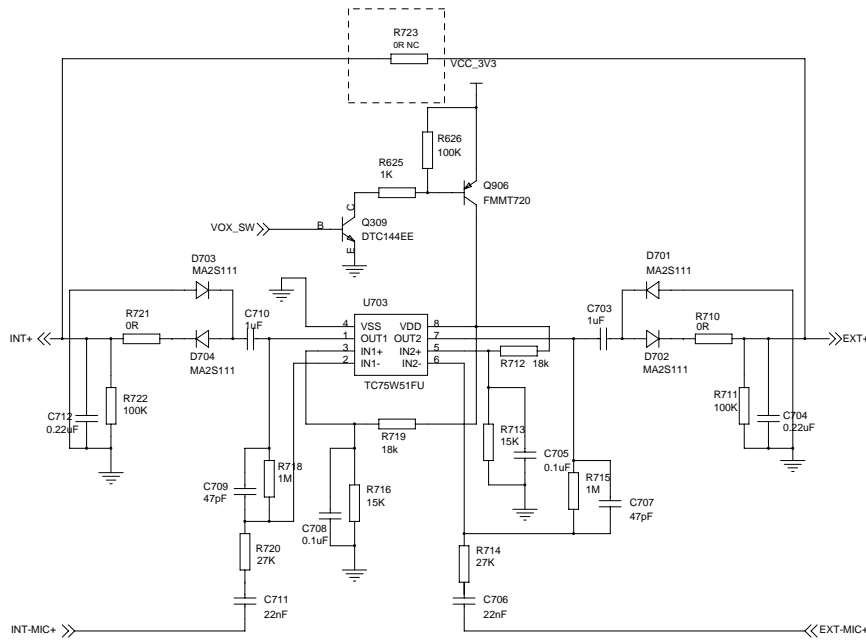
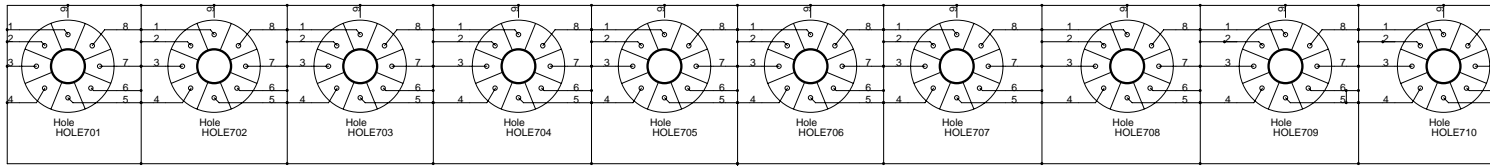

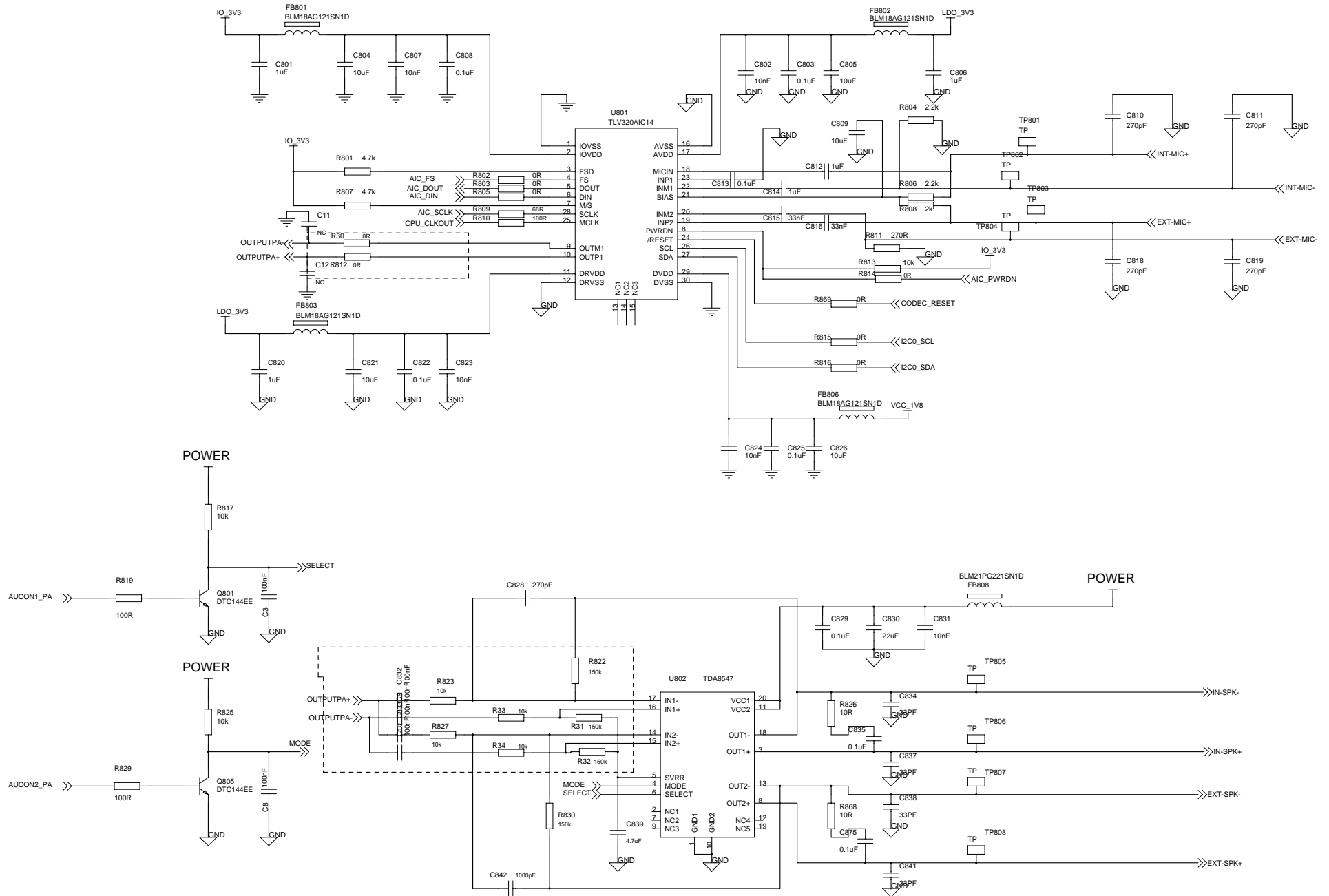

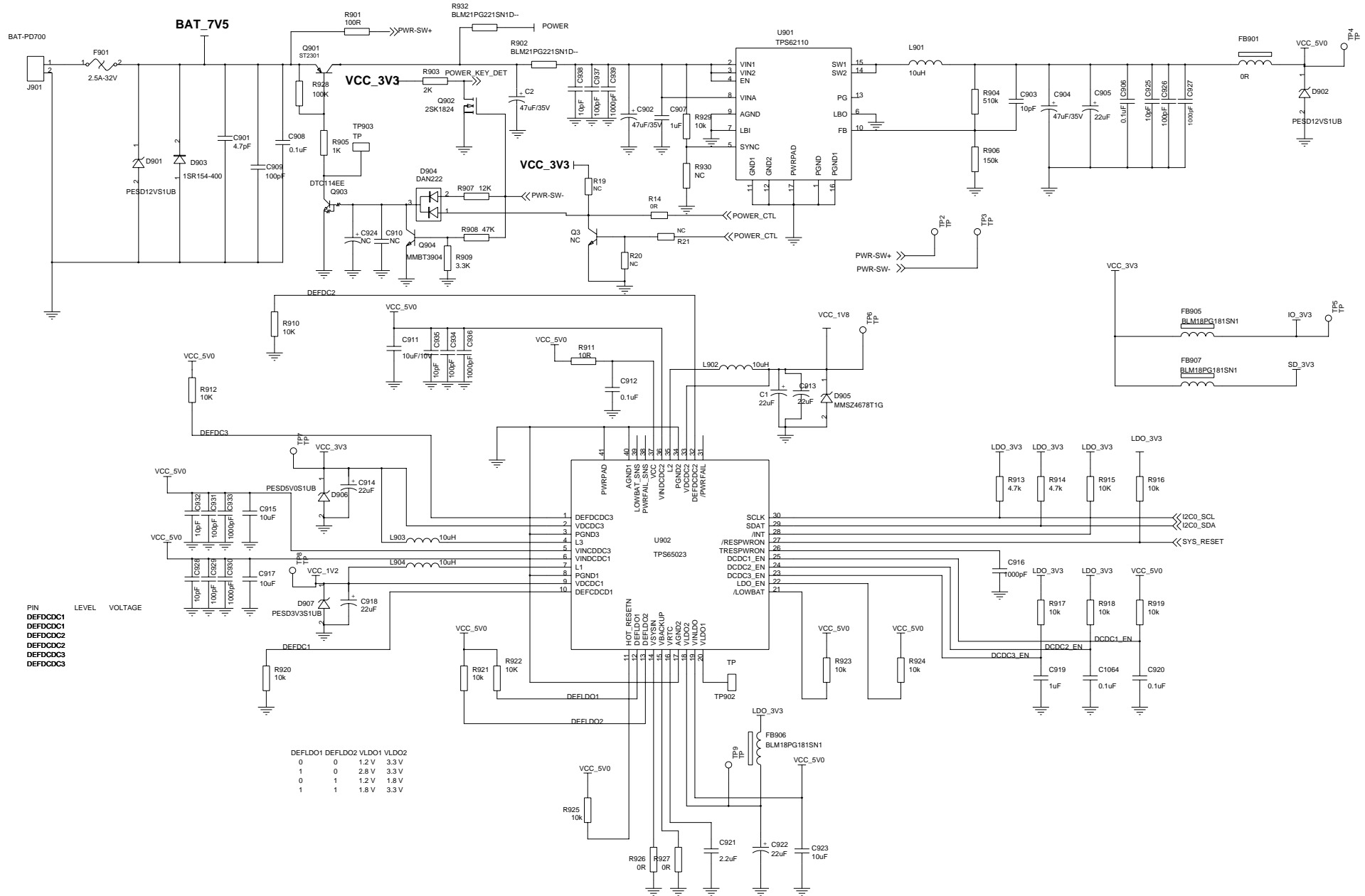

# Appendix Figure 6 DP770 UHF Keypad Schematic Diagram

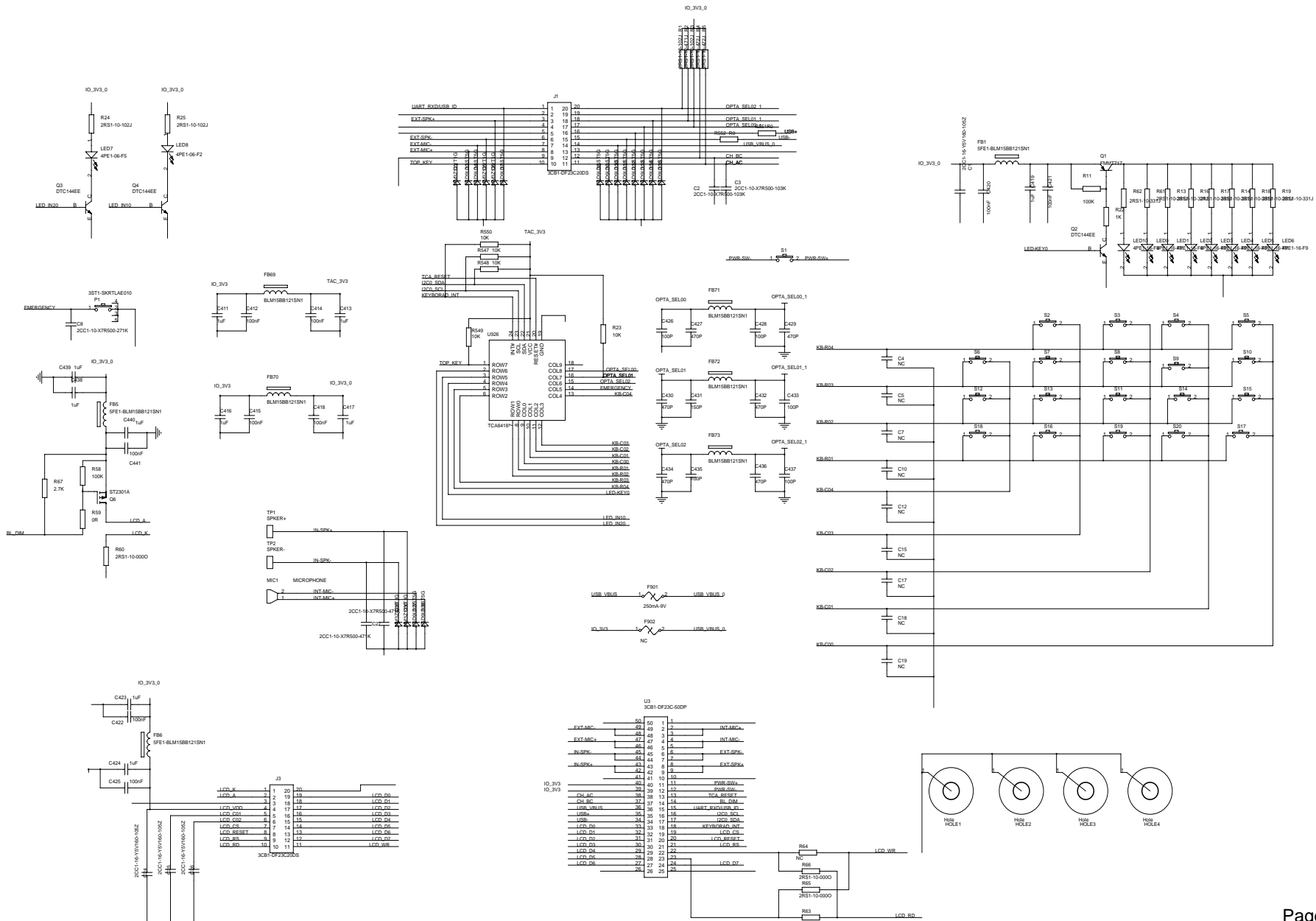

# Appendix Figure 7 DP770 VHF Main Board Top Side PCB View

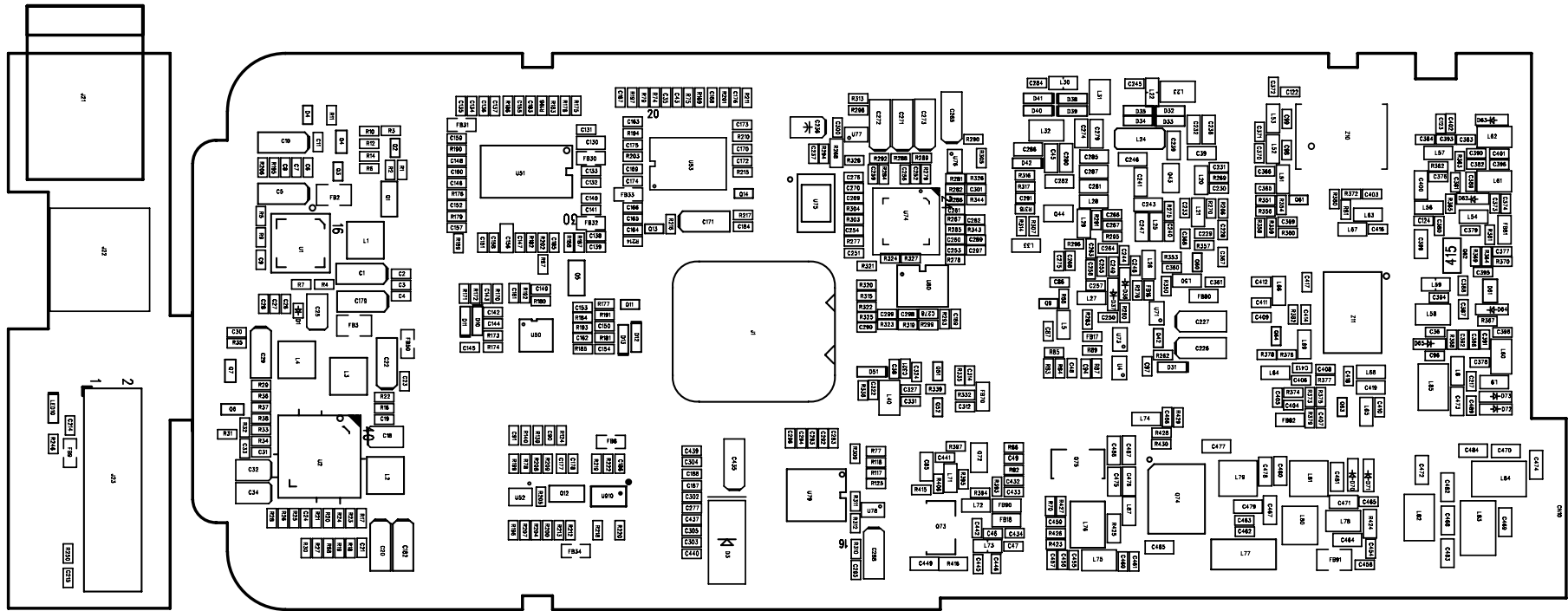

# Appendix Figure 8 DP770 VHF Main Board Bottom Side PCB View

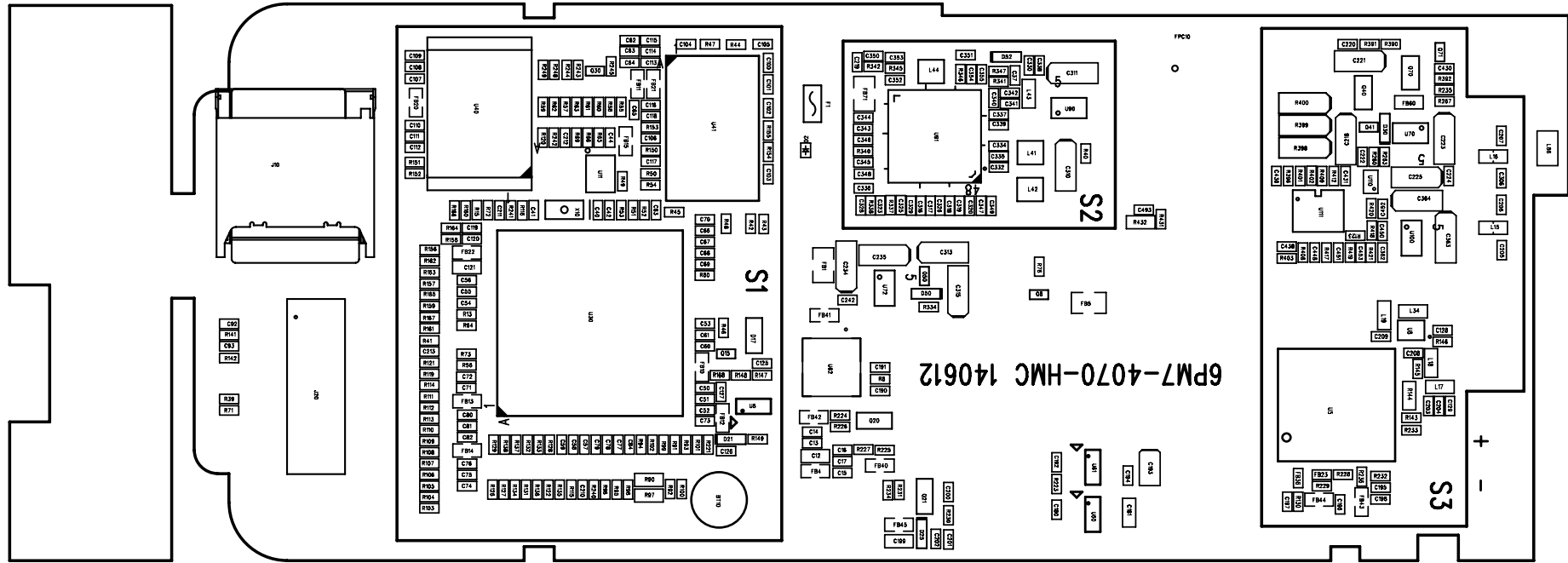



# Appendix Figure 9 DP770 VHF Keypad Top Side PCB View

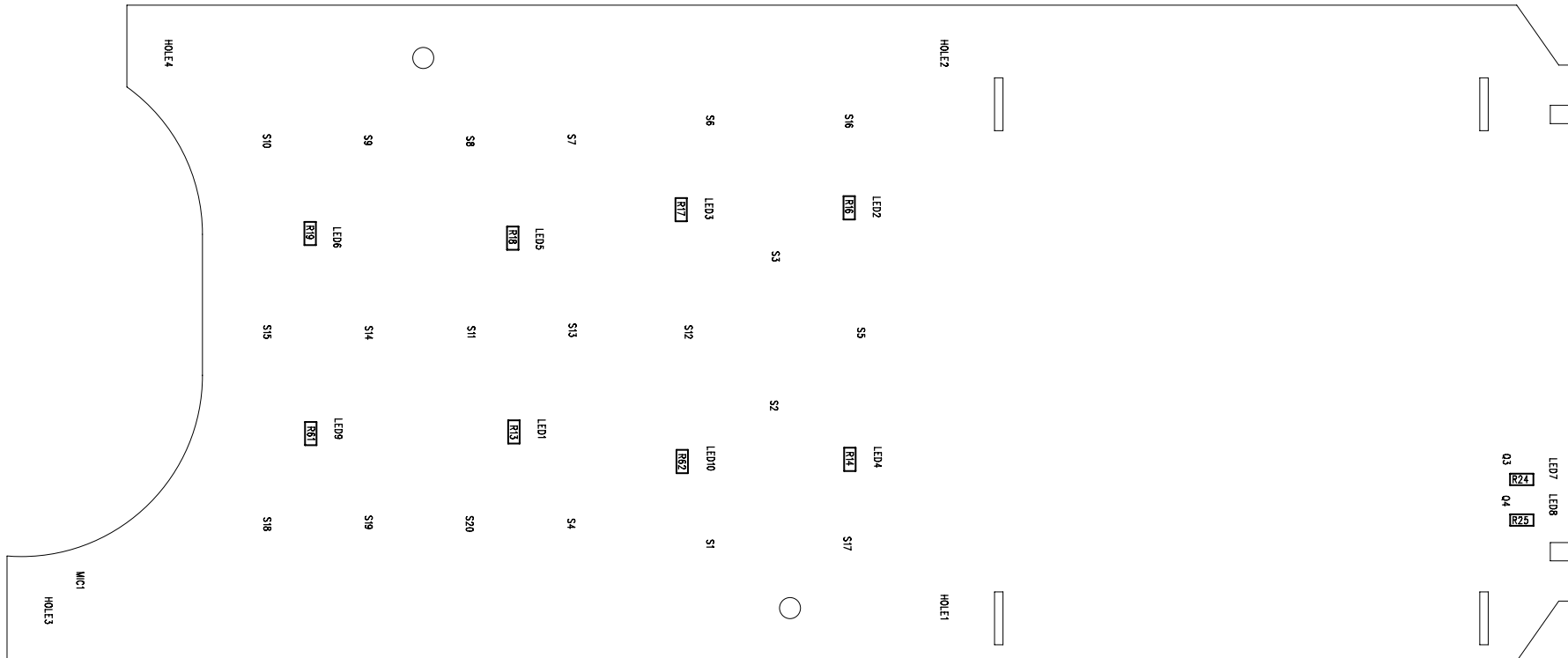

# Appendix Figure 10 DP770 VHF Keypad Bottom Side PCB View

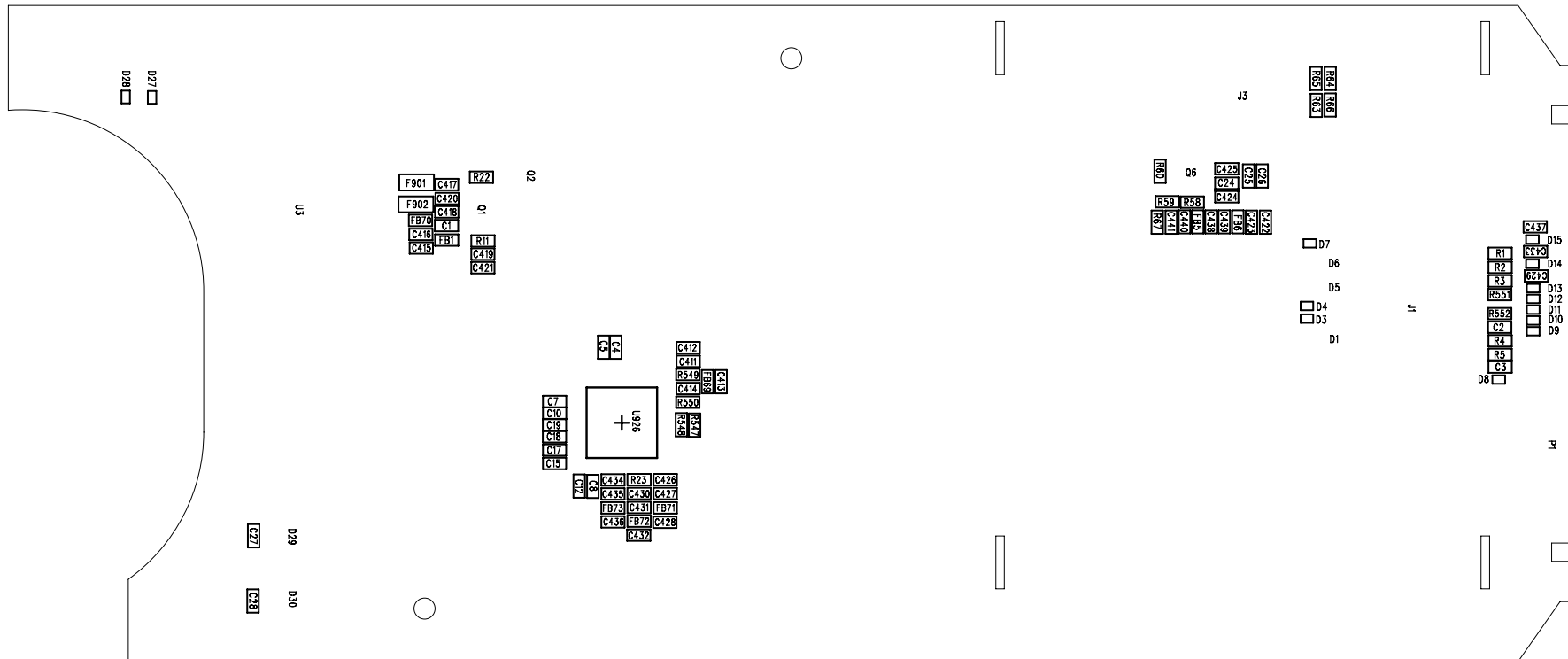



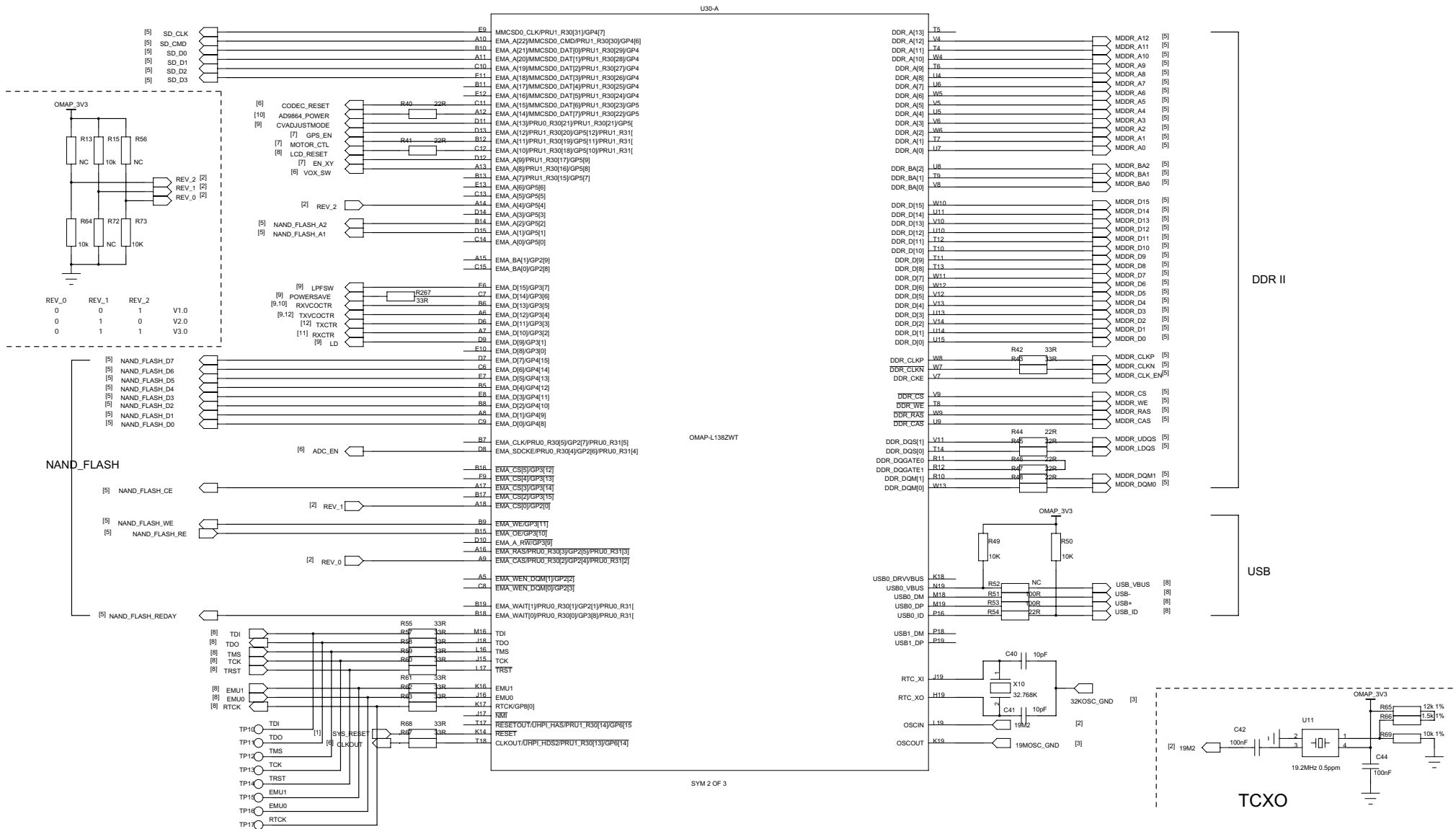

OMAP-L138ZWT

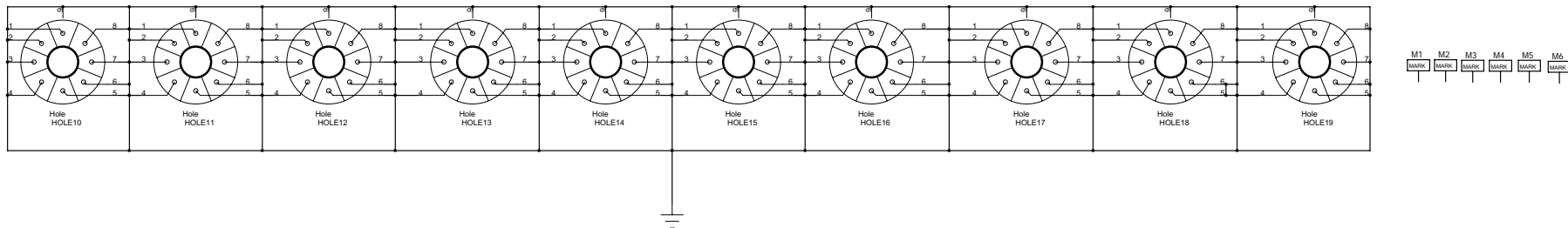
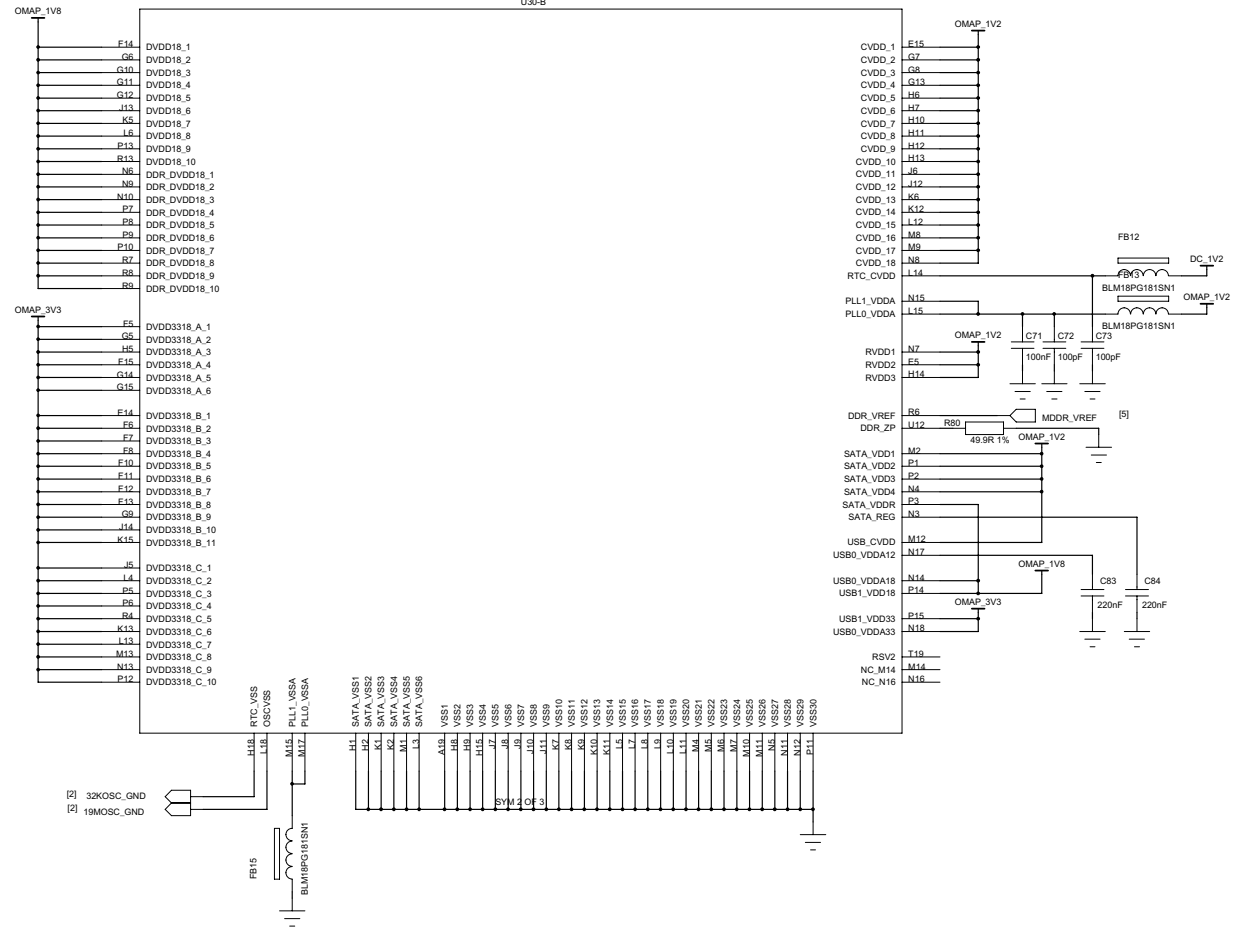
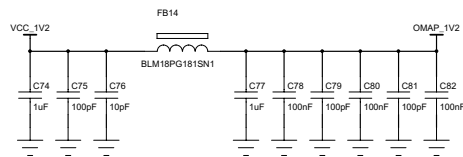
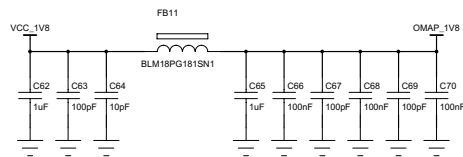
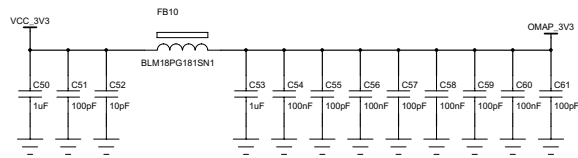

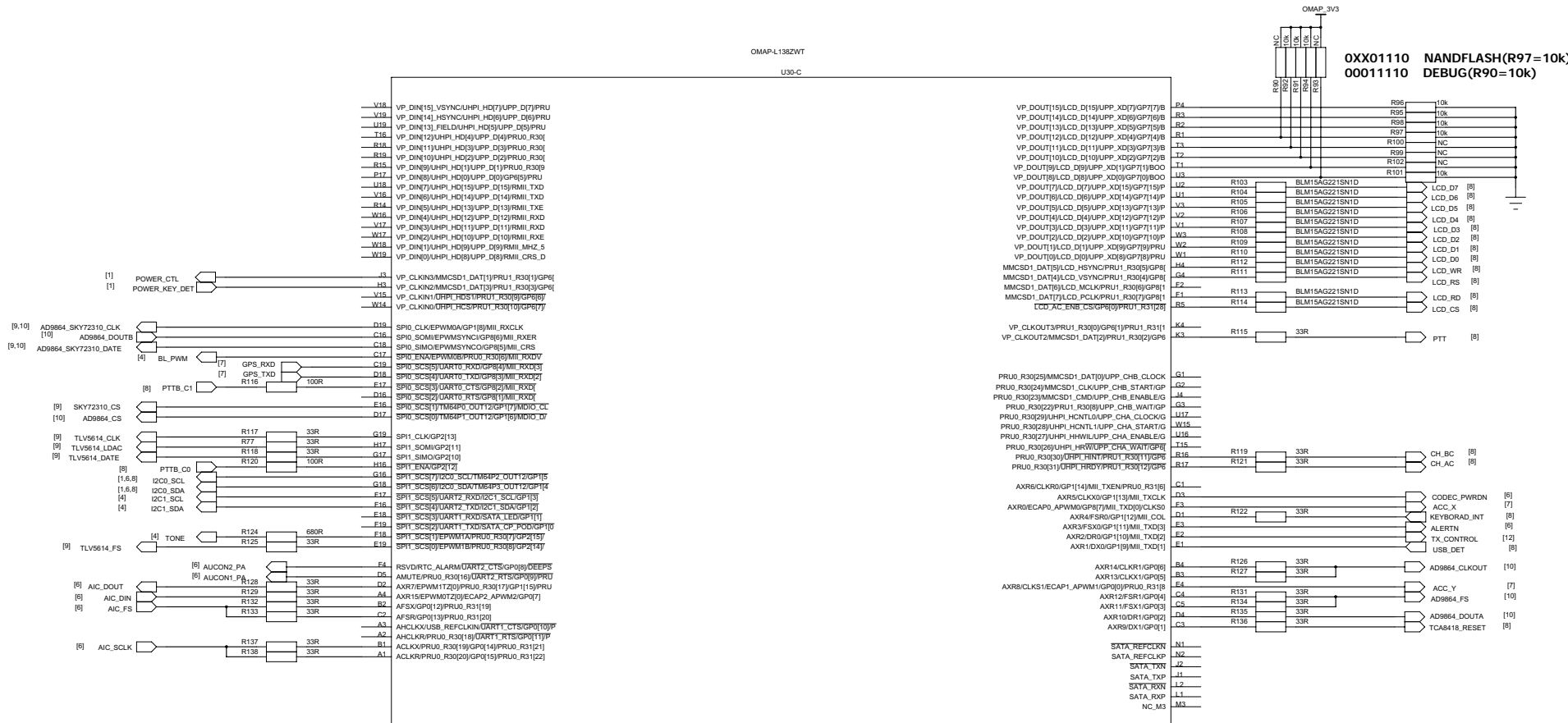
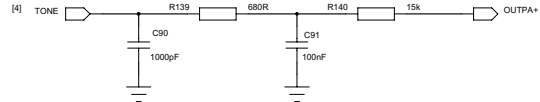
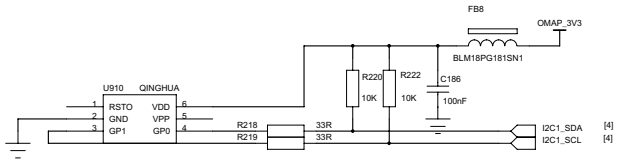

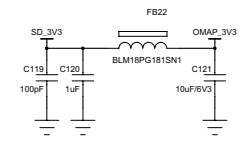
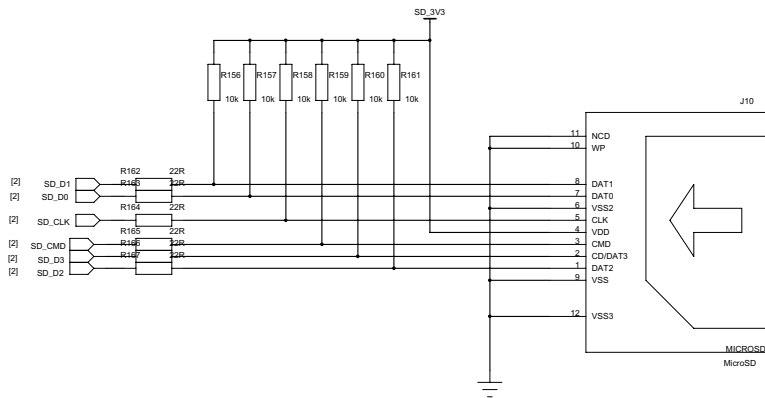
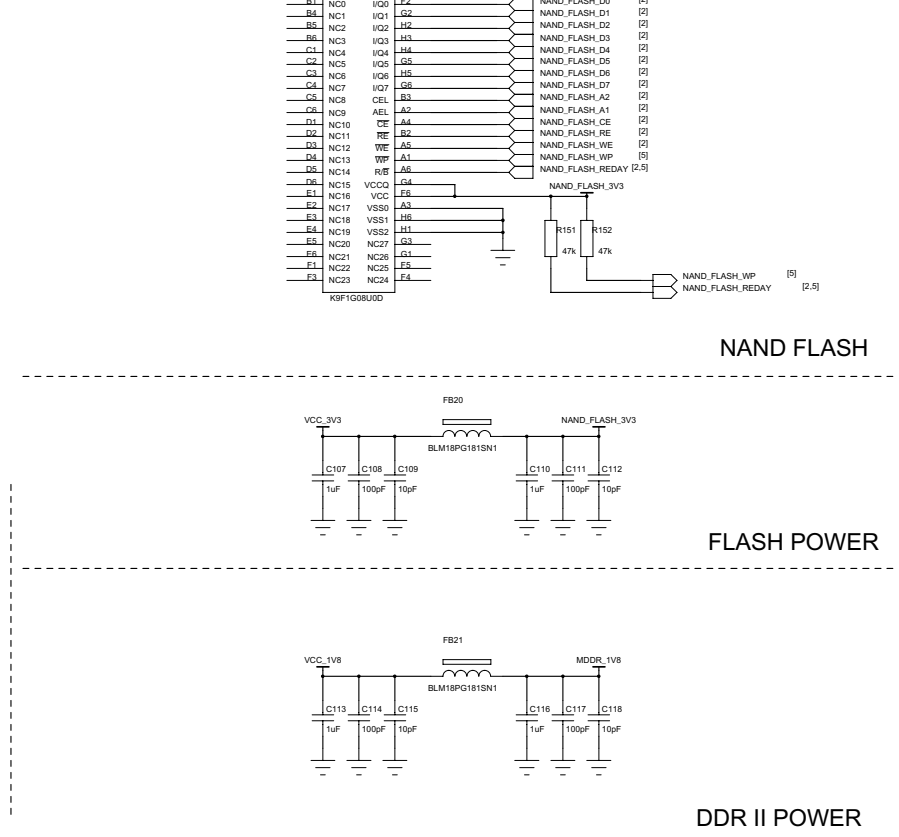
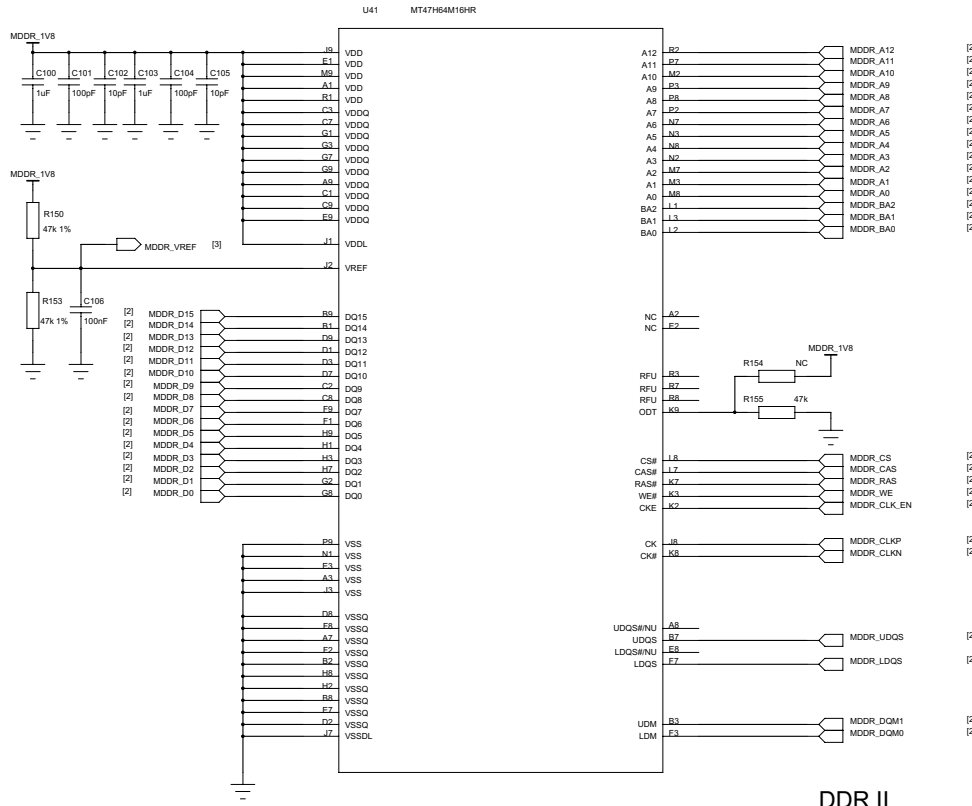

SD CARD

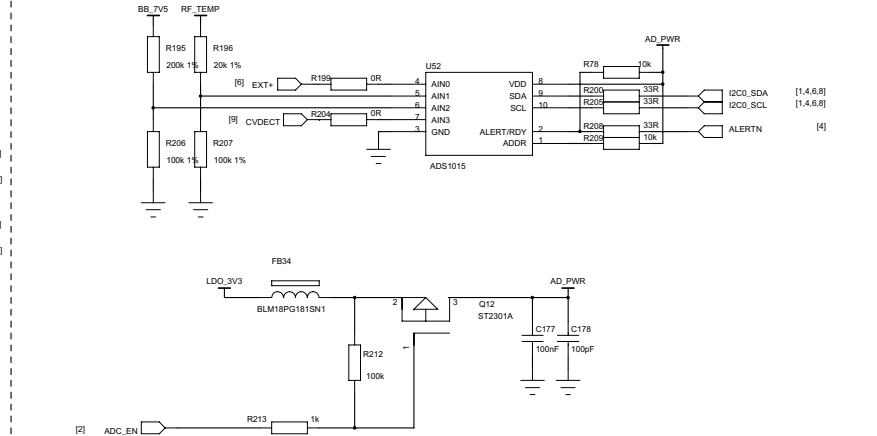
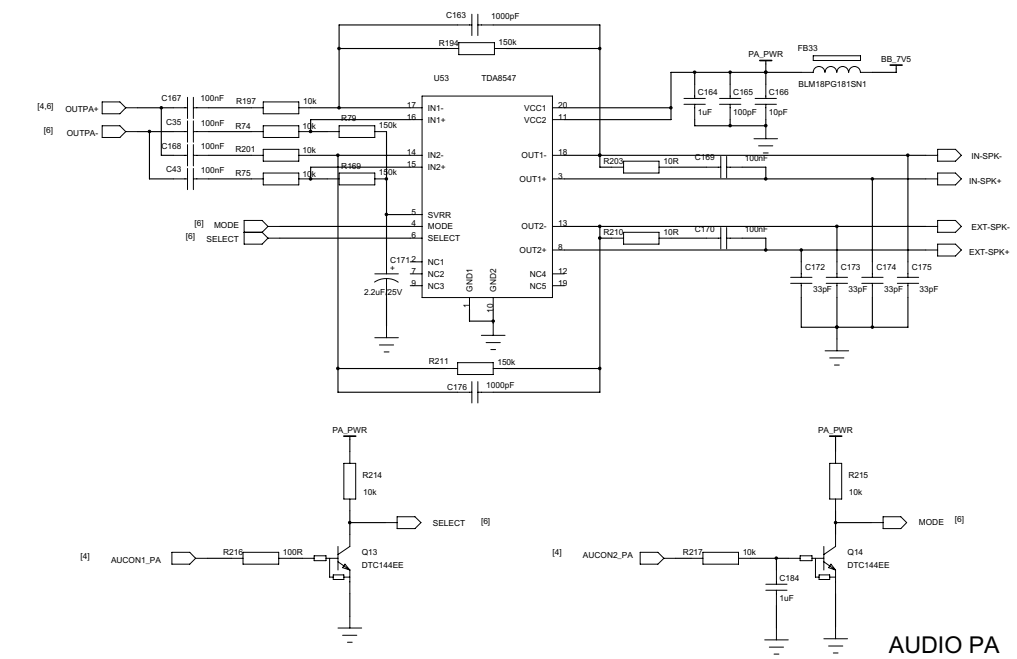
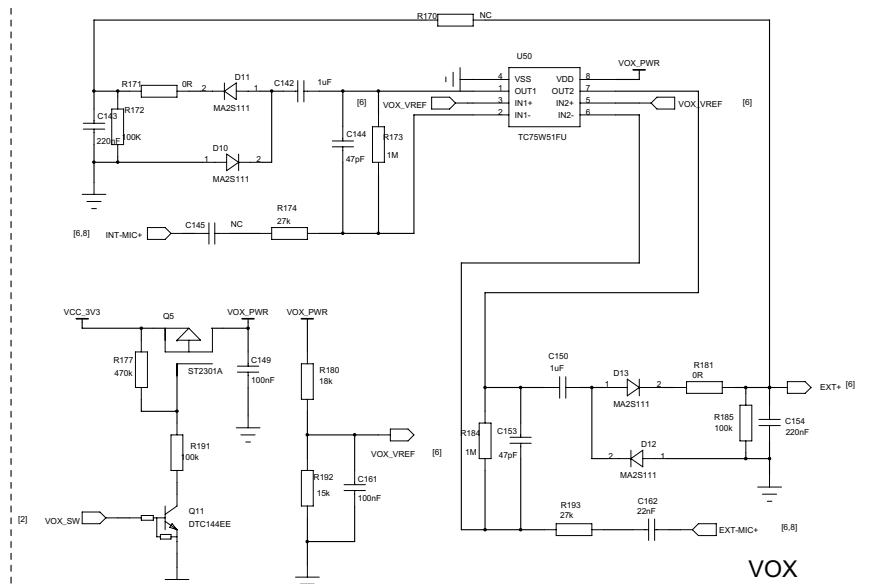
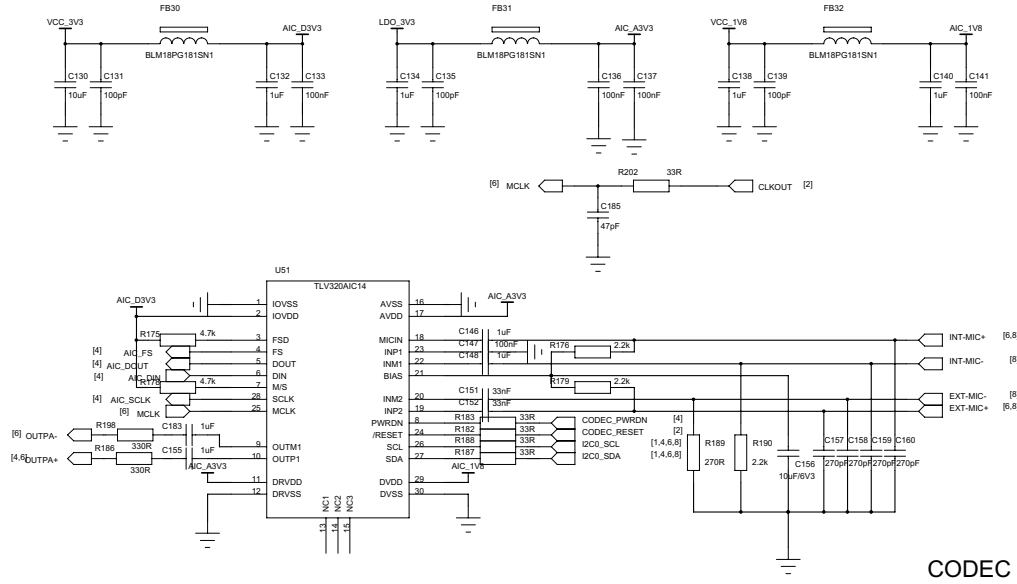



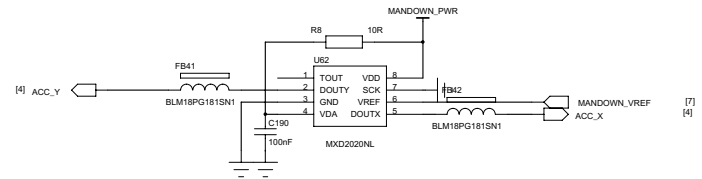
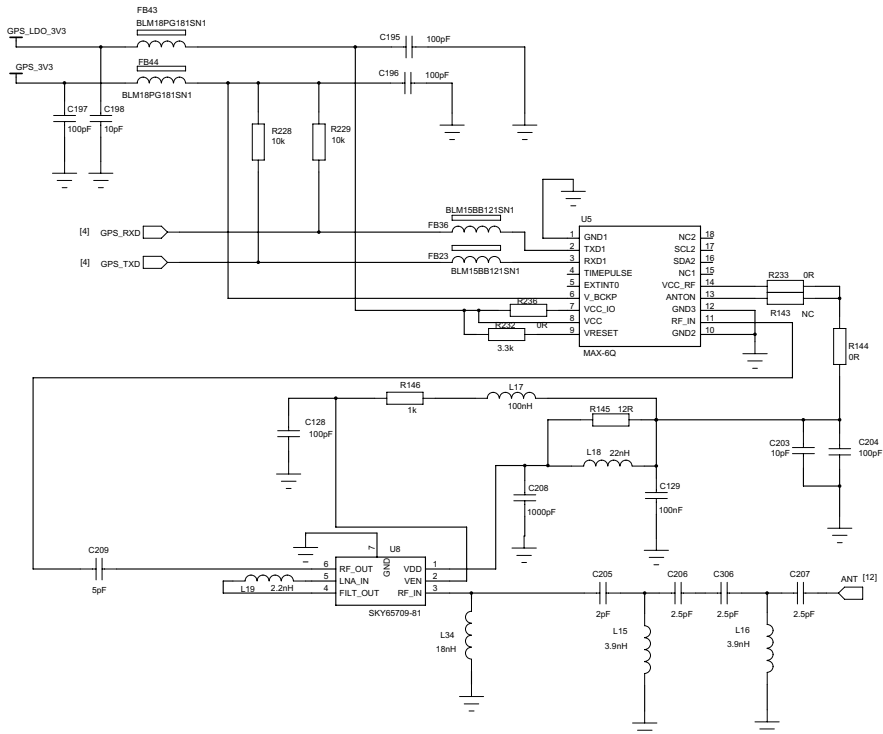
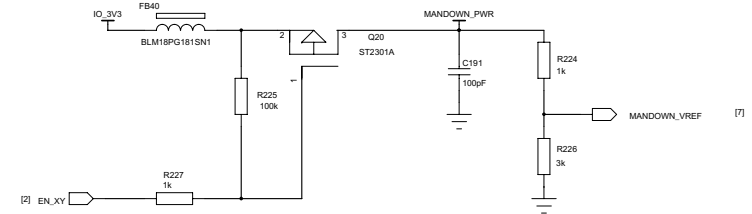
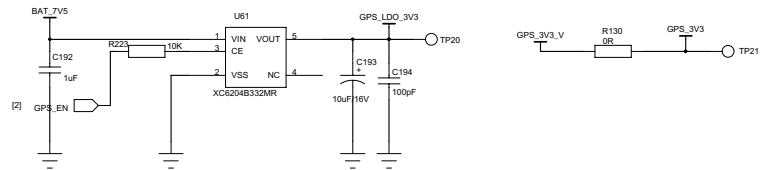
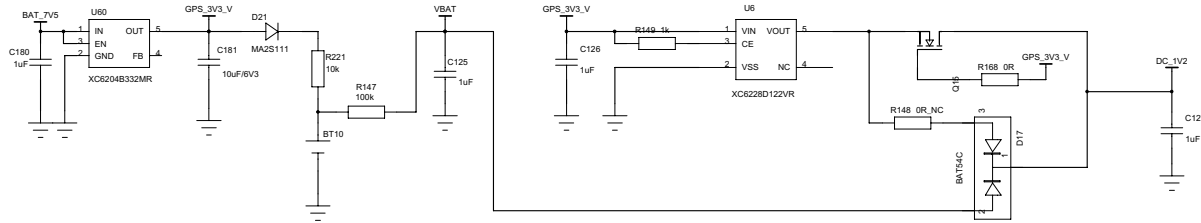

MAN DOWN

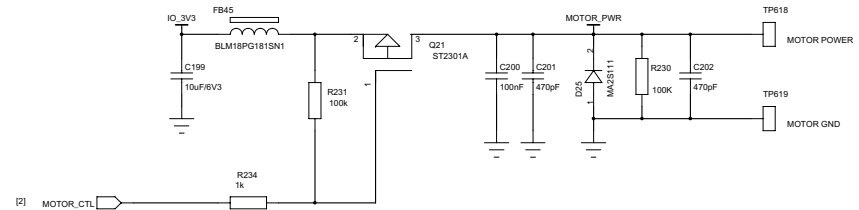

MOTOR

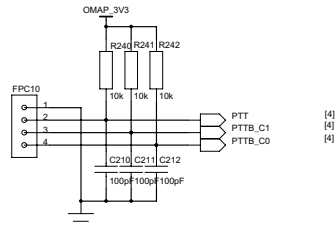

PTT KEY

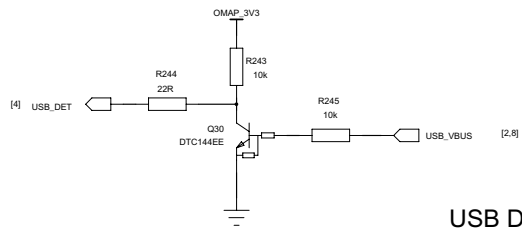

USB DECT

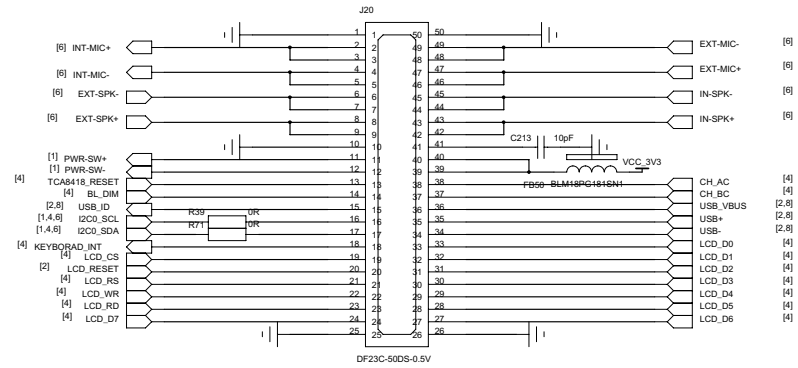
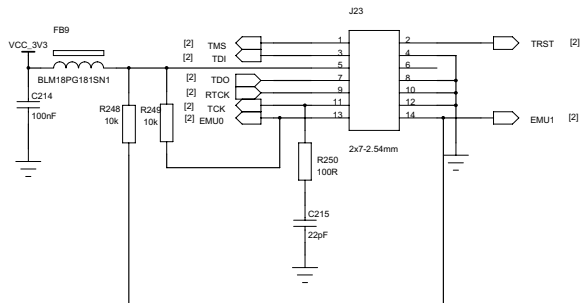
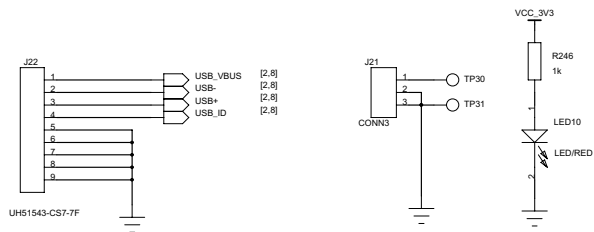

KEY BOARD INTFACE

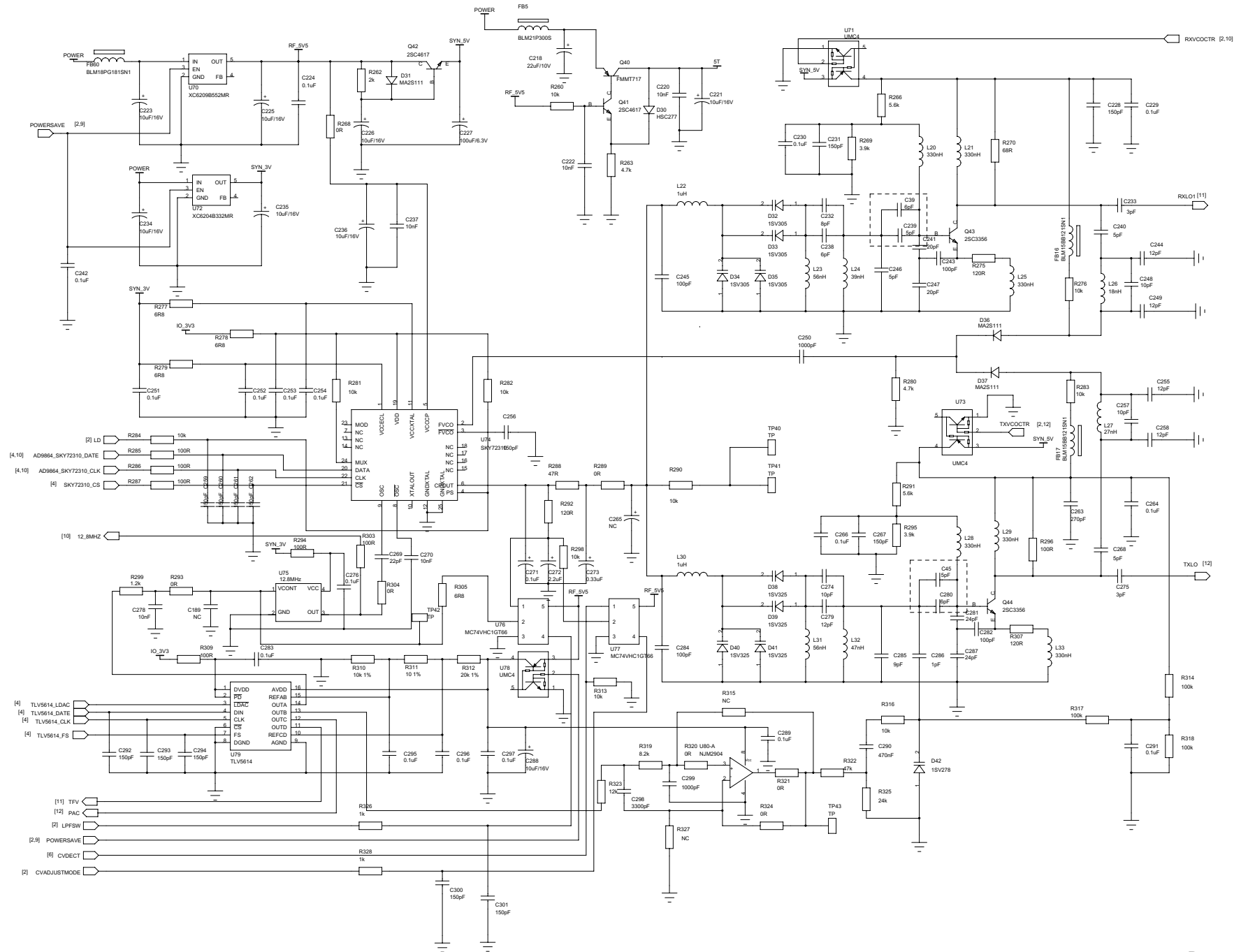

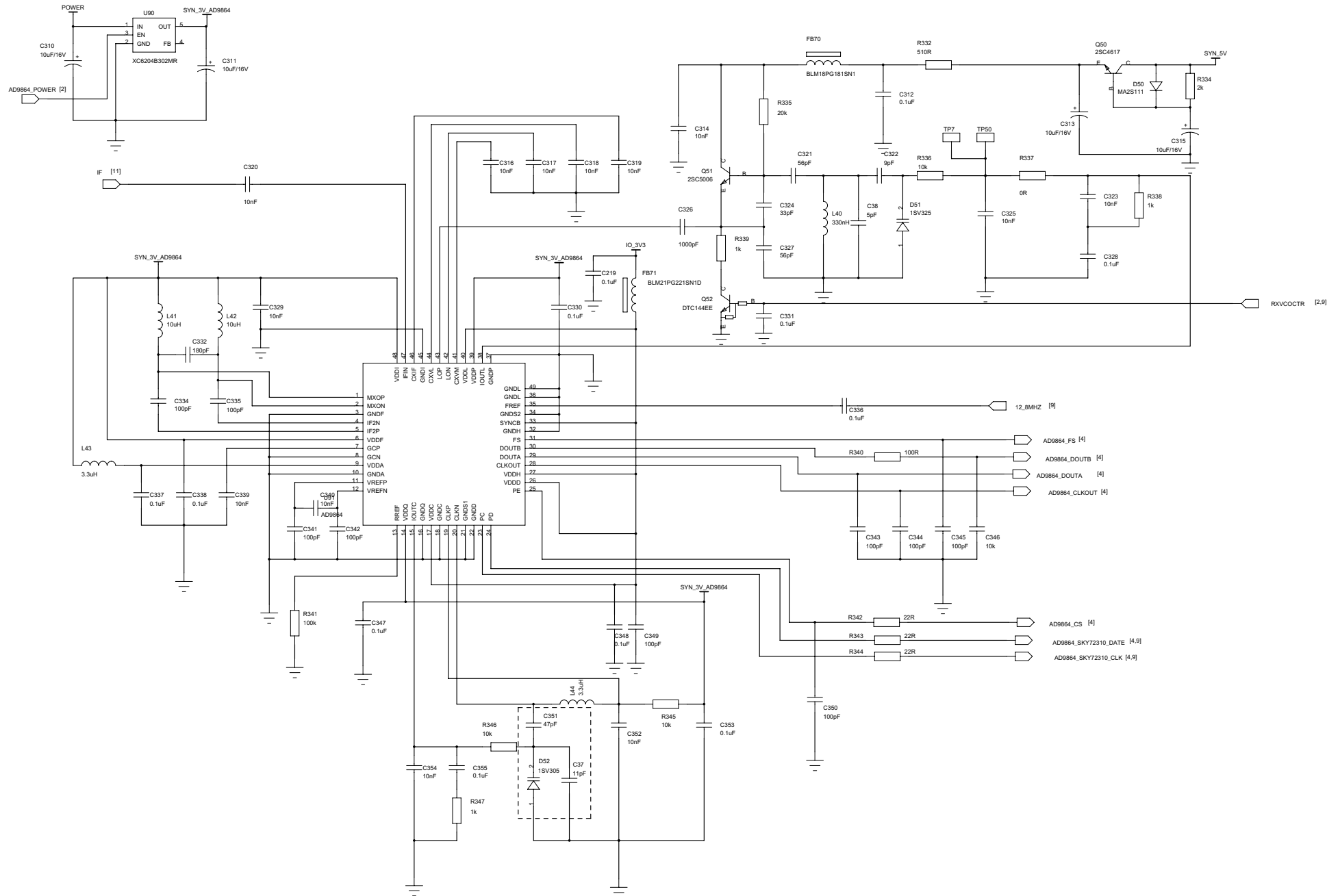

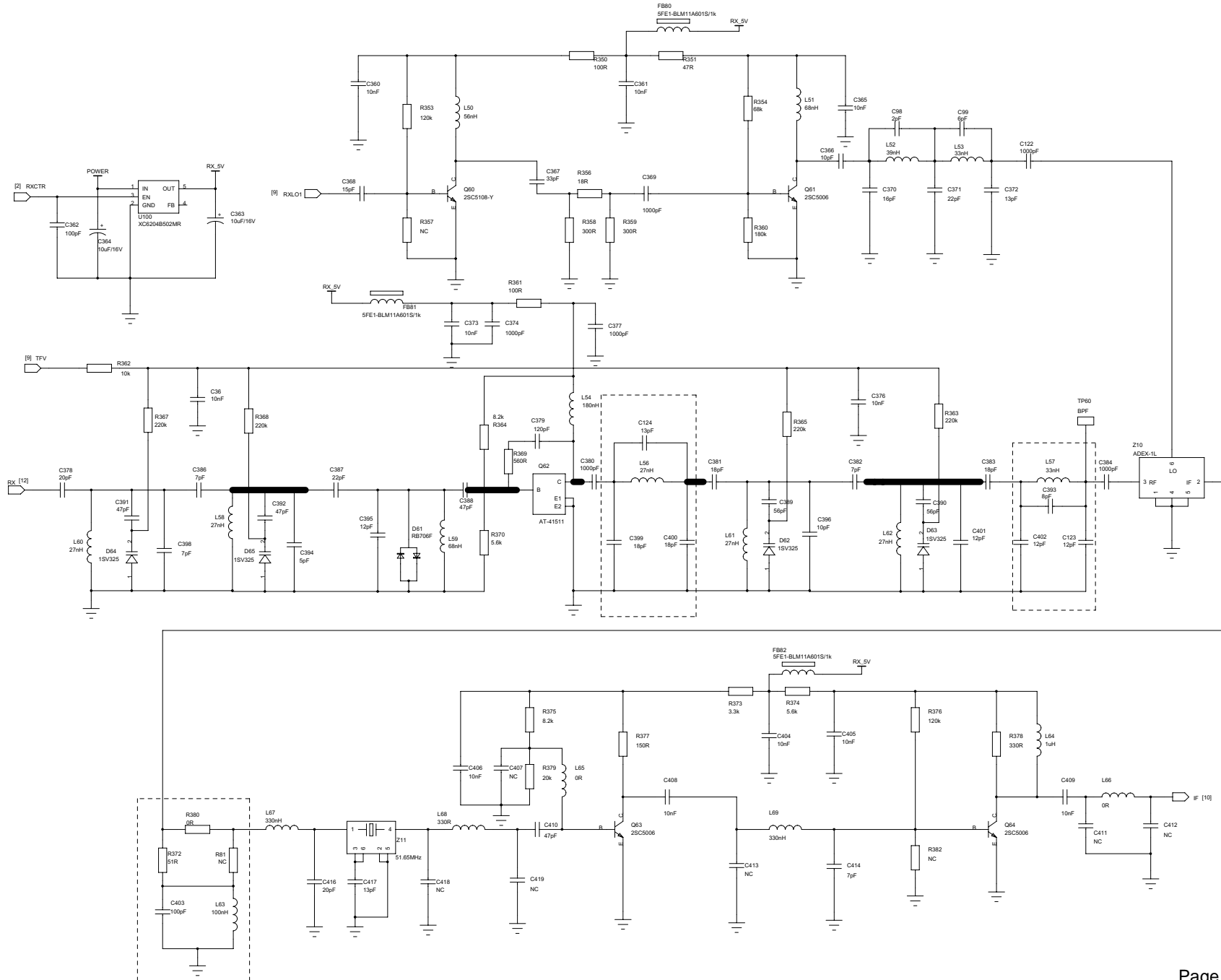

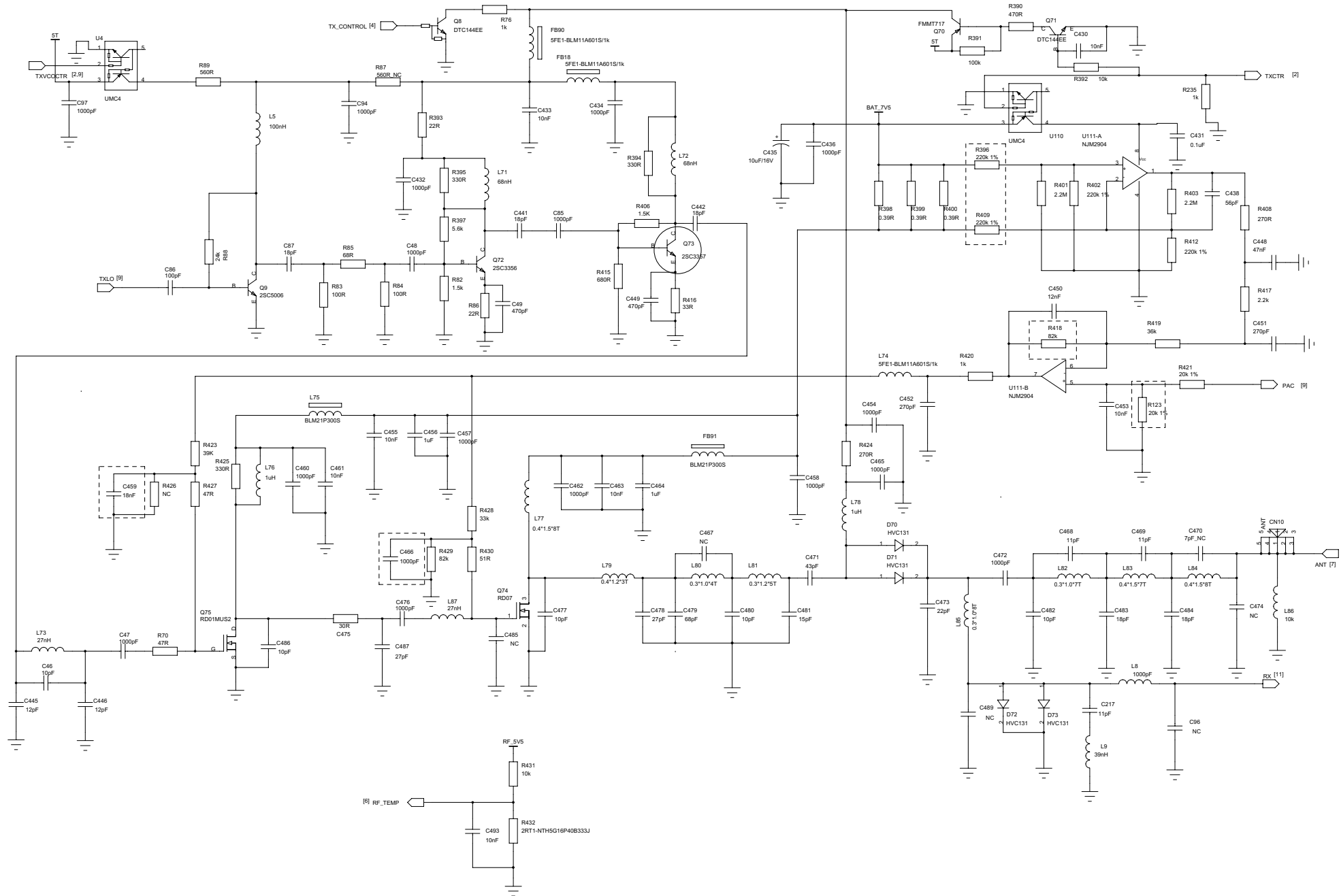

# Appendix Figure 12 DP770 VHF Keypad Schematic Diagram

