



- Shear beam load cell
- Option T for model 350 with blind loading hole
- Versions:
 - **350Ti**: Fully Stainless Steel construction. Hermetically sealed, fully welded, IP 68 (EN 60529) and IP 69K (ISO 20653)
 - **350Ta**: Stainless Steel construction. Silicone sealing, IP 66 (EN 60529)
- 3000 divisions OIML R60 class C
- Pre-corner adjustment optimized for multicell systems
- Available in **ATEX**  version (optional) Zone 0-1-2 (gas) and 20-21-22 (dust)
- High accuracy on industrial applications specially for four load cells platforms
- Scherstab-Wägezelle
- Option T für Modell 350 Sacklochversion für Kugelpkopfkrafteinleitung
- Ausführungen:
 - **350Ti**: Edelstahl, hermetisch dicht verschweißt, IP 68 (EN 60529) und IP 69K (ISO 20653)
 - **350Ta**: Edelstahl, vergossen, IP 66 (EN 60529)
- 3000 Teile OIML R60 Klasse C
- Abgeglicherer Ausgang für problemlose Parallelschaltung
- Erhältlich in **ATEX**  -Ausführung (optional) Zone 0-1-2 (Gas) und 20-21-22 (Staub)
- Hohe Genauigkeit bei industriellem Einsatz:
 - Plattformwaagen mit 4 Wägezellen
 - Behälter-und Silowaagen

Model Modell	Nominal capacity Nennlast Ln	Accuracy class Genauigkeitsklasse n. OIML	Minimum division Kleinster Teilungswert vmin	Service load Gebrauchslast 150 % Ln	Safe load Grenzlast 200 % Ln
350 300 kg	300 kg	3000	30 g	450 kg	600 kg
350 500 kg	500 kg	3000	50 g	750 kg	1000 kg
350 750 kg	750 kg	3000	75 g	1125 kg	1500 kg
350 1000 kg	1000 kg	3000	100 g	1500 kg	2000 kg
350 1500 kg	1500 kg	3000	150 g	2250 kg	3000 kg
350 2000 kg	2000 kg	3000	200 g	3000 kg	4000 kg



MODEL 350 T (300...2000 kg)

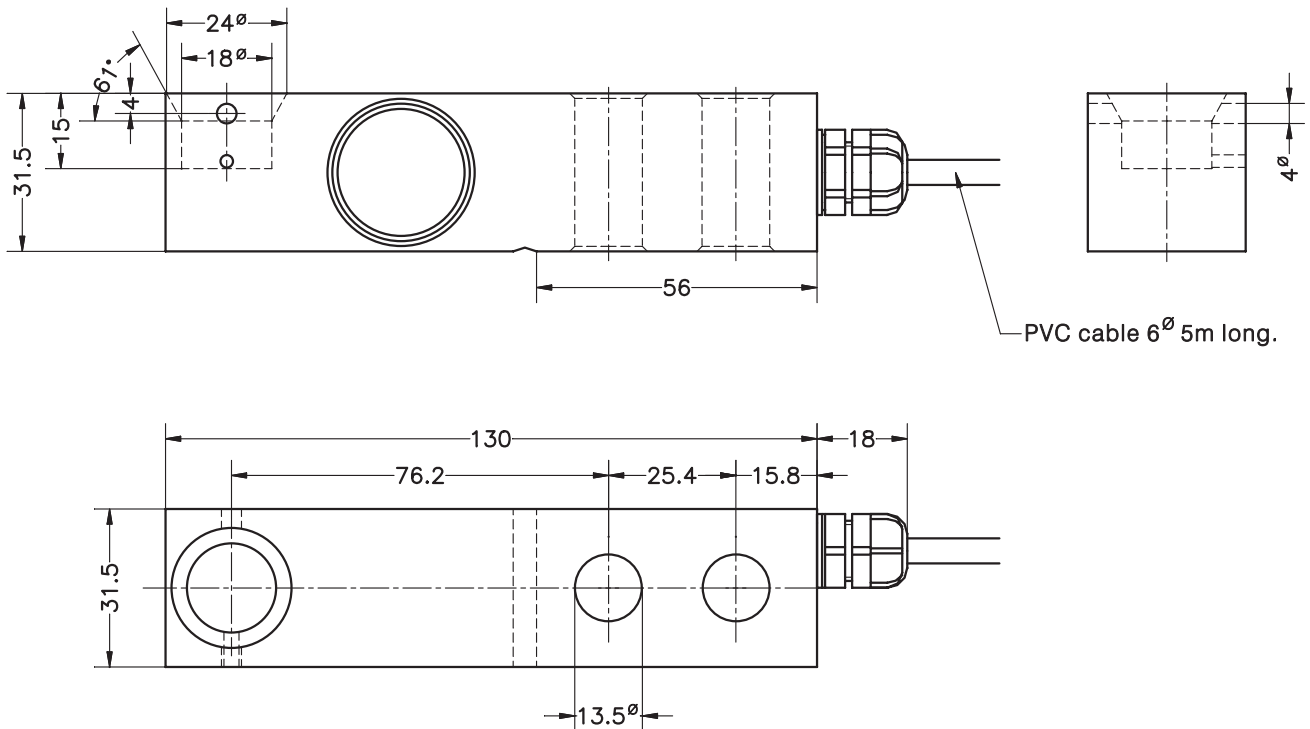

Dimensions in mm. Abmessungen in mm.

Transport weight - Transportgewicht: 0.9 kg

SPECIFICATIONS			TECHNISCHE DATEN
Nominal capacities (Ln)	300-500-750-1000-1500-2000	kg	Nennlasten (Ln)
Accuracy class	3000	n. OIML	Genauigkeitsklasse
Minimum dead load	0	%Ln	Minimale Vorlast
Service load	150	%Ln	Gebrauchslast
Safe load limit	200	%Ln	Grenzlast
Total error	< ±0.017	%Sn (1)	Zusammengesetzter Fehler
Repeatability error	< ±0.015	%Sn	Wiederholgenauigkeit
Temperature effect: on zero	< ±0.01	%Sn/5 °C	Temperaturfehler: Nullpunkt
on sensitivity	< ±0.006	%Sn/5 °C	Kennwert
Creep error (30 minutes)	< ±0.016	%Sn	Kriechfehler (30 min)
Temperature compensation	-10...+40	°C	Nenntemperaturbereich
Temperature limits	-30...+70	°C	Arbeitstemperaturbereich
Nominal sensitivity (Sn)	2	mV/V (2)	Nennkennwert (Sn)
Nominal input voltage	10	V	Nom. Speisespannung
Maximum input voltage	15	V	Max. Speisespannung
Input impedance	400 ±20	Ω	Eingangswiderstand
Output impedance	350 ±3	Ω	Ausgangswiderstand
No load output	< ±2	%Sn	Nullsignaltoleranz
Insulation resistance	> 5000	MΩ	Isolationswiderstand
Maximum deflection (at Ln)	0.2-0.4	mm	Nennmessweg (bei Ln)

ELECTRICAL CONNECTION
ELEKTRISCHER ANSCHLUSS:

MOD. 350 Ta

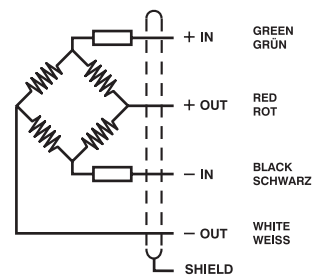

350 Ti

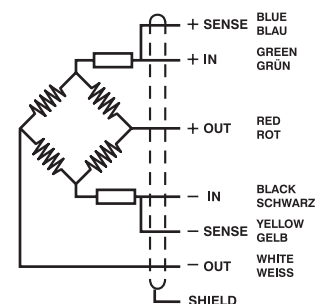

(1) Total error: Non Linearity and Hysteresis / Zusammengesetzter Fehler: Nichtlinearität und Hysterese

(2) Pre-corner adjustment optimized at ±0.05% by output current calibration /
Auf ±0.05% optimierter Eckenvorabgleich durch Stromkalibrierung des Ausgangssignals

LOAD FOOT ACCESSORY FOR MODEL 350 T
SELBSTZENTRIERENDER LASTFUSS FÜR MODELL 350 T

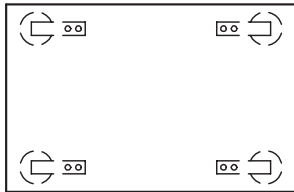

Mod. **350**
+
Acc. **35916i**

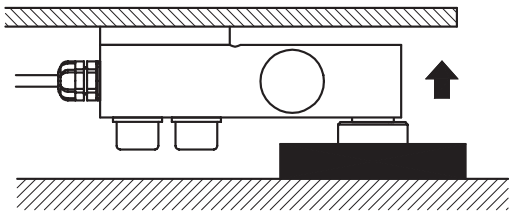

- Materials: Stainless Steel and Rubber
- Material: Edelstahl und Elastomer

Acc. **35916i** for Model 350 option T (300...2000 kg) / Für Modell 350 Option T (300...2000 kg)

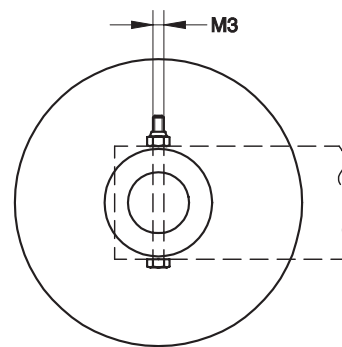
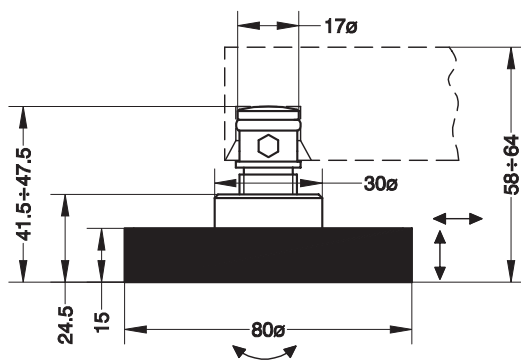

Dimensions in mm. Abmessungen in mm.

Transport weight - Transportgewicht: 0.3 kg