

# InTrac 7XX e

## Instruction manual



**METTLER TOLEDO**

© It is forbidden to reprint this instruction manual in whole or part.

No part of this manual may be reproduced in any form, or modified, copied or distributed using electronic systems, in particular in the form of photocopies, photographs, magnetic or other recordings, without written consent of Mettler-Toledo GmbH, Process Analytics, CH-8902 Urdorf, Switzerland.

All rights reserved, in particular reproduction, translation and patenting/registration.

- InTrac, InPro, InFlow, EasyClean and InFit are trademarks of the METTLER TOLEDO Group.
- ISM is a registered trademark of the METTLER TOLEDO Group in Switzerland, USA, the European Union and a further five countries.
- All other trademarks are the property of their respective owners.
- Viton and Kalrez are registered trademarks of Du Pont Performance Elastomers LLC.

# **InTrac 7XXe**

## **Instruction manual**

## Product and maintenance log

---

Product name : \_\_\_\_\_

Article no. : \_\_\_\_\_

Serial no. : \_\_\_\_\_

A logbook of activities should be maintained for the above-mentioned product, recording all data about events, adopted measures, manipulations etc. relative to the product, such as checking of the shipment, initial installation, service/maintenance, repair work, startup and shutdown etc.

## How to use this Instruction manual

---

This Instruction Manual is an integral part of the METTLER TOLEDO retractable housing InTrac® 7XXe and contains notes and instructions that are important for safety and operation.

All persons working on or with the InTrac 7XXe must have first read and understood the Chapters appropriate to the work in hand.

Please read this Instruction Manual carefully before using the InTrac housing. Keep this document close to the unit, so that operating personnel may easily be able to refer to it at any time.



**Caution! Please first read Chapter 1 "Introduction" on page 9 and Chapter 2 "Important notes for housing uses in Ex-Classified area" on page 21.**



### Use of warnings and symbols

**Danger!** Warning of a dangerous situation that can lead to extensive material damage, to death or grave bodily injury.



**Caution!** Warning of a possible dangerous situation that can lead to light bodily harm and/or material damage.



**Attention:** Information referring to technical requirements. Non-adherence can lead to malfunctions, uneconomic working and possibly also to loss of productivity.

### Explanation of housing designations

The designation InTrac 7XXe used in this Instruction Manual covers reference to the following housings:

- **InTrac 776 e**
- **InTrac 777 e**
- **InTrac 779 e**
- **InTrac 797 e**
- **InTrac 799 e**

The designation InTrac 7X7e refers to the following housings:

- **InTrac 777 e and InTrac 797 e**

The designations InTrac 77Xe or InTrac 79Xe refer to the following housings:

- **InTrac 777 e, InTrac 776 e and InTrac 779 e resp. InTrac 797 e and InTrac 799 e**

# Contents

---

<b>1</b>	<b>Introduction</b>	<b>9</b>
1.1	Housing designations	10
1.2	Basic principles	10
1.3	Warning notices and symbols	11
1.4	Responsibilities, organizational measures	11
1.4.1	Responsibilities of operator	11
1.4.2	Responsibilities of personnel	12
1.4.3	Selection and qualifications of personnel – basic duties	12
1.5	Product-specific hazards	13
1.5.1	Sensor design	13
1.5.2	Manipulation of and maintenance work on the housings	14
1.5.3	Housings with immersion depth H = 70 mm	14
1.5.4	Polymer housings	15
1.5.5	Installation in pressurized systems	16
1.5.6	Installation in potentially explosive areas (hazardous areas)	16
1.6	Residual hazards	17
1.6.1	Rupture of pneumatic or hydraulic connections	17
1.6.2	Leaky connections	17
1.6.3	Malfunctions in overriding control and safety systems	17
1.6.4	Electricity or control (compressed) air failure	18
1.6.5	Medium residues	18
1.6.6	Manually operated housings	18
1.6.7	Pneumatically operated housing	19
1.6.8	Heat protection	19
1.6.9	External influences	19
1.7	Emergency measures	19
1.8	Safety measures	20
1.9	Modifications	20
<b>2</b>	<b>Important notes for housing uses in Ex-Classified area</b>	<b>21</b>
2.1	Notes on operating instructions	21
2.2	Intended use	21
2.3	Safety instructions	22
2.4	Correct disposal of the housing	23
2.5	Use in Ex-zones	23
2.6	Ex-classification ATEX	23
2.6.1	Introduction	23
2.6.2	Special conditions	24
2.7	Ex-classification FM approved	25
2.7.1	Introduction	25
2.7.2	Special conditions	26
2.7.3	Applied standards:	26
<b>3</b>	<b>Product descriptions</b>	<b>27</b>
3.1	Scope of delivery	27
3.2	Packing	27
3.3	Checking the shipment	27
3.4	Product overview	28
3.5	Construction of the retractable housings	29
3.5.1	Operating modes of the retractable housings	29
3.5.2	Lower part of housing for process adaption	31

3.6	Description of function of retractable housings	34
3.6.1	Manually operated versions	34
3.6.2	Pneumatically operated versions	36
<b>4</b>	<b>Installation and start-up</b>	<b>39</b>
4.1	Preparation of the equipment	39
4.2	Fitting and installation work	40
4.2.1	Fitting the housing	40
4.2.1.1	Fitting via a weld-in socket	40
4.2.1.2	Fitting via a flange	40
4.2.1.3	Fitting via NPT external thread	41
4.2.1.4	Fitting via Tri-Clamp and Varivent flange connection	41
4.2.2	Attaching the flushing lines (single flushing chamber)	41
4.2.3	Attaching the flushing lines (double flushing chamber)	43
4.2.4	Pneumatic-connections	44
4.2.5	Fitting of 3/2-way valve for position indicator	45
4.2.6	Fitting of inductive position indicators (Ex-proof or non-Ex)	45
4.2.7	Installing the temperature sensor	46
4.2.8	Fitting the electrode/sensor	46
4.3	Startup procedures for housings	49
4.3.1	Startup of manually operated housings	49
4.3.2	Startup of pneumatically operated housings	50
4.4	Shutdown procedure for manually and pneumatically operated housings	51
4.5	Dismantling work	51
4.5.1	Removing the electrode/sensor	51
4.5.2	Removing the retractable housing	53
4.6	Using cables with BNC plugs or preamplifiers (ISFET electrodes)	53
4.7	Use of retractable housings in conjunction with EasyClean	54
<b>5</b>	<b>Operation</b>	<b>55</b>
5.1	Important information for everyday operation	55
5.2	Inspection work in everyday operation	55
5.3	Cleaning the electrode/sensor	56
5.4	Calibrating the measuring system	56
<b>6</b>	<b>Maintenance</b>	<b>57</b>
6.1	Important information on maintenance	57
6.2	Topping up reference electrolyte	59
6.3	Conversion of InTrac 777e to InTrac 776e	59
6.4	Replacing seals in contact with the process medium	59
<b>7</b>	<b>Trouble shooting</b>	<b>62</b>
<b>8</b>	<b>Product specifications</b>	<b>64</b>
8.1	Technical data	64
8.1.1	Technical specifications InTrac 776e	64
8.1.2	Technical specifications for InTrac 77Xe/InTrac 79Xe	66
8.2	Spare parts list	68
<b>9</b>	<b>Decommissioning, storage, disposal</b>	<b>69</b>
9.1	Decommissioning	69
9.2	Storage	69
9.3	Disposal	69

---

<b>10</b>	<b>Appendices</b>	<b>70</b>
10.1	Electrode/sensor selection	70
10.2	Dimensional drawing InTrac 776e	71
10.3	Dimensional drawing InTrac 777e/InTrac 779e	72
10.4	Dimensional drawing InTrac 797e/InTrac 799e	73
10.5	Product structure InTrac 776e/InTrac 777e/InTrac 779e	74
10.6	Product structure InTrac 797e/InTrac 799e	75

---



# 1 Introduction

---

- The retractable housing InTrac 7XXe is safe to operate. When used correctly, it represents no danger.
- Before starting to use the housing, carefully read this instruction manual: the safety precautions and warnings contained in it must be observed.
- The retractable housing has been tested by METTLER TOLEDO and dispatched ready for installation.

**In addition to this instruction manual please also note the following:**

- all local safety regulations concerning the execution of pneumatic and water installations.
- all instructions and warning remarks in the publications of the products that are used in conjunction with the retractable housing (electrodes, sensors, controls, etc.).
- all safety precautions for the plant into which the retractable housing will be installed.
- all instructions and warnings labeled on the retractable housing.
- all safety information relative to operation in potentially explosive atmospheres/hazardous areas (Ex classified zones).

The instruction manual contains the most important information for using InTrac 7XXe efficiently and in accordance with regulations. A basic condition for safe handling and operation without malfunctions is a knowledge of these safety instructions and observance of the further warnings in the instruction manual.

This instruction manual, and in particular the safety regulations, are intended for personnel entrusted with the operation and maintenance of the retractable housing. It is assumed that these persons are familiar with the equipment in which the retractable housing is installed. Therefore, before any work is started with the retractable housing, this instruction manual must be read and understood by those persons involved.

The instruction manual must be stored where it is constantly accessible and available to any person working with the InTrac 7XXe.

On receipt of the shipment, check immediately:

- the retractable housing and accessories for any sign of transport damage. Report any damage immediately to the carrier and to your supplier.
- the type designation on the housing body.
- for completeness of the supply. Please notify your supplier immediately if the shipment is incomplete or in any way incorrect (see Chapter 3.1 "Scope of delivery" on page 27).

## 1.1 Housing designations

Housing designation as well as article no. and serial no. for clear identification when communicating with the manufacturer can be noted from the type plate.



**Attention:** The specifications shown on the type plate are dependent on the design and individual type of housing and have no general validity for the complete InTrac program.

### Example of InTrac 7XX housing type plate

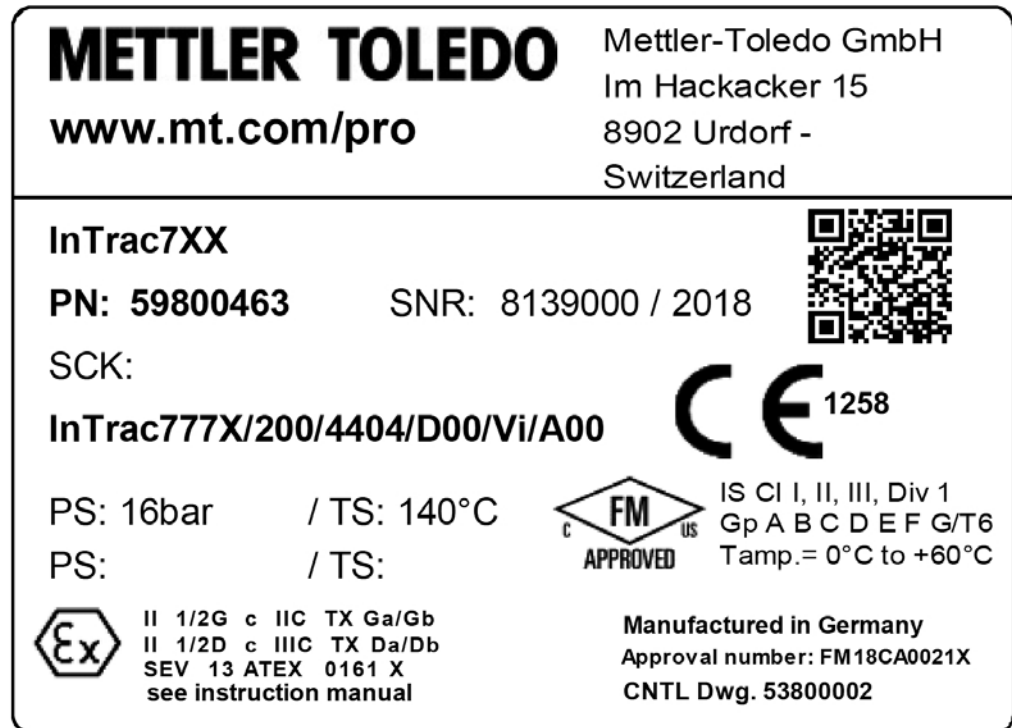

Note: The label shown only as an example. Depending on appropriate compliances (i.e. ATEX, FM, PED or others), the final label may be different.

## 1.2 Basic principles

The retractable housing InTrac 7XXe is built in accordance with state-of-the-art technology and recognized technical safety regulations.

However, the housing can be a source of risks and dangers:

- if the housing is operated by insufficiently trained persons.
- if the housing is not used in compliance with regulations and/or stipulations for appropriate use.

InTrac 7XXe may only be used in a technically correct condition for the purpose intended by the supplier, with awareness by the user of safety and danger factors, taking the Instruction Manual and local safety regulations into consideration.

Malfunctions and damage that can affect the safety and function must immediately be remedied by the operator or an expert, and notified to the manufacturer in writing!



**Danger!** A defective retractable housing must neither be installed nor put into operation. Faulty containment and installation out of conformance with regulations and instructions can lead to the escape of medium or to pressure surges (explosion), potentially harmful both to persons and to the environment.

## 1.3 Warning notices and symbols

The following symbols are used in this Instruction Manual to mark safety instructions:



**Danger!** Warning of a dangerous situation that can lead to extensive material damage, to death or grave bodily injury.



**Caution!** Warning of a possible dangerous situation that can lead to light bodily harm and/or material damage.



**Attention:** Information referring to technical requirements. Non-adherence can lead to malfunctions, uneconomic working and possibly also to loss of productivity.

## 1.4 Responsibilities, organizational measures

### 1.4.1 Responsibilities of operator

- The operator is under obligation only to permit persons to work with InTrac 7XXe retractable housings, who are familiar with the basic requirements of work safety and accident prevention, and who have been instructed in the handling of the housing. This Instruction Manual serves as the basic document.
- In addition to the instruction manual there are also generally valid legal and other binding regulations for work safety and accident prevention as well as for environmental protection, and these must be provided by the operator and instructed to personnel using the housings.
- The operator/user must be fully aware of safety and potential danger factors during work with the housings and this awareness must be checked by the operator at regular intervals.
- Measures must be taken to ensure that the retractable housings are only operated in a safe and fully functional condition.
- If the housings are employed in hazardous areas, compliance with prevailing regulations is to be ensured.



**Caution!** Before the retractable housing is put into operation, the operator must have already clarified that use of the housing in conjunction with the other associated equipment and resources is fully authorized.

## 1.4.2 Responsibilities of personnel

- All persons whose duty it is to operate the retractable housings are under obligation to read Chapter 2 “Important notes for housing uses in Ex-Classified area” on page 21 as well as the warning notices in this Instruction Manual.
- In addition to the Instruction Manual, generally valid legal and other binding regulations for work safety and accident prevention must be adhered to.
- Any method of working which is doubtful from a safety perspective and which exceeds the operation according to regulations must be omitted.
- Avoid using high-pressure water jets to clean any parts and components of the housing.



**Attention:** Before every start-up, the retractable housing must be checked for:

- damage to the connections, fastenings, etc.
- leakage
- perfect functioning
- authorization for use in conjunction with other plant equipment and resources.



**Danger!** A defective retractable housing may neither be installed nor put into operation.

Faulty containment or installation out of conformance with regulations and instructions can lead to the escape of medium or to pressure surges (explosion), potentially harmful both to persons and to the environment.

## 1.4.3 Selection and qualifications of personnel – basic duties

- Work on or with the retractable housings may only be carried out by reliable and appropriately trained or instructed personnel. The personnel must have read this Instruction Manual in advance.
- Clear responsibilities/ standard operation procedures (SOPs) must be established for the personnel entrusted with operation, service, repair, etc. of the housings.
- It must be ensured that only specifically assigned personnel may operate the housings.



**Danger!** Incorrect manipulation or operation of the housings or non-observance of safety regulations can lead to problems with the housings and to the escape of process medium, thereby presenting a potential hazard to the environment, personnel and material.

## 1.5 Product-specific hazards

### 1.5.1 Sensor design



**Danger!** The electrode or sensor may only be removed from a mounted retractable housing when this is in the "Maintenance" (retracted/withdrawn) position, since if the electrode/sensor is missing from the housing, there will be path for the process medium to escape to the environment. This can endanger personnel and cause damage to the environment and material. Toxic or aggressive media can pose a threat to human life through poisoning, chemical burns or scalding.



**Attention:** If an electrode/sensor is broken, it must be replaced immediately.



**Danger!** A broken sensor jeopardizes process safety, since it is not then possible to achieve reliable measurement results.



**Attention:** The anti-twist locking device (positive position rod) in the housings InTrac 7X7e and InTrac 7X9e makes it difficult for any unintentional removal of the electrode/sensor from the retractable housing when in the "Measuring" position. This locking feature is basically intended as an anti-twist safety device for the immersion tube. However the rod can be screwed out and its use is optional except in cases of critical cleaning processes, where it is then absolutely necessary in order to ensure optimal flow of cleaning/flushing media to the sensor in the flushing chamber. The positive position rod cannot be used with the housing InTrac 776e.

Principally, personal protective equipment such as protective goggles and clothing must be worn.

Any manipulation of the electrode/sensor may only be carried out when the retractable housing is in the retracted/withdrawn position ("Maintenance" position).



**Danger!** Plastic housing bodies can become weakened if exposed to aggressive gases, direct sunlight, or hot air temperature. If any of these conditions exist in the housing's installation environment, the housing body should be checked regularly and replaced annually. Contact your local METTLER TOLEDO representative for more information.

#### "Maintenance" position of the housings

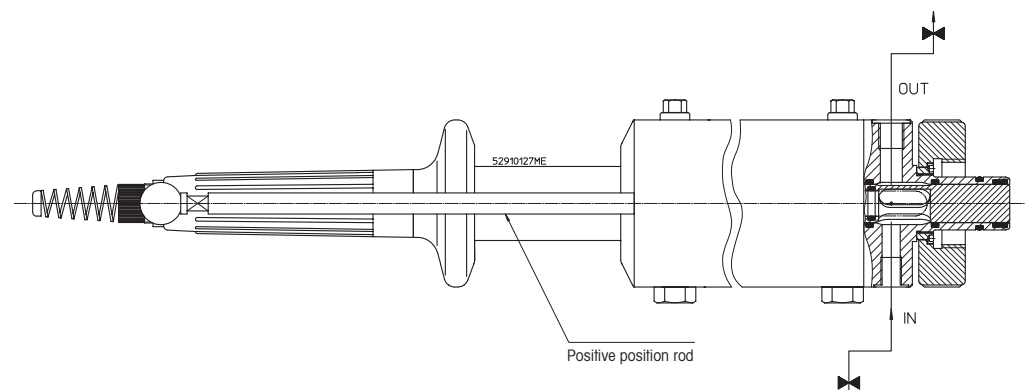

## 1.5.2 Manipulation of and maintenance work on the housings

 **Attention:** Before dismantling a retractable housing or commencing any maintenance work on it, ensure that the equipment in which the retractable housing is installed is in a safe condition (depressurize, no explosion risk, empty, rinse, vent, etc.). Retractable housings may only be stripped down after having been completely dismantled.

Manipulation of the housings may only take place after it has been ensured that no process medium can escape through the housing in the event of incorrect manipulation. For this reason, the complete system must be emptied and vented in advance (**safe condition**).

If the retractable housing has been in operation in conjunction with the automated cleaning and calibration system EasyClean, it must be ensured that before any manipulation of the housing, the EasyClean system has been completely switched off and isolated (power, compressed air and water).

It is principally necessary to wear personal protective outfit such as protective goggles and clothing.

Only such maintenance and repair work as is specifically described in this Instruction Manual may be performed on the retractable housing.

Only original spare parts from METTLER TOLEDO may be used for replacing defective components (see Chapter 8.2 "Spare parts list" on page 66).

 **Danger!** Non-compliance with the prescribed maintenance instructions can endanger personnel and the environment.

## 1.5.3 Housings with immersion depth H = 70 mm

 **Caution!** Housings with an immersion depth of 70 mm cannot assure permanent sealing of the process medium from the flushing chamber during insertion and retraction operations. Consequently, process liquid can enter the flushing chamber, resulting in cleaning medium mixing with process medium.

### Retraction procedure

Measuring position  $\longrightarrow$  Maintenance position

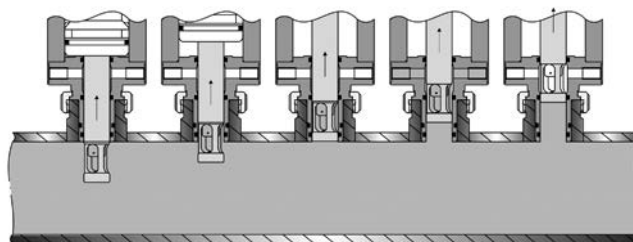

 **Attention:** In order to provide a smoother insertion and retraction motion of the housing, the O-ring (see drawing Pos.1) can be removed by the customer.

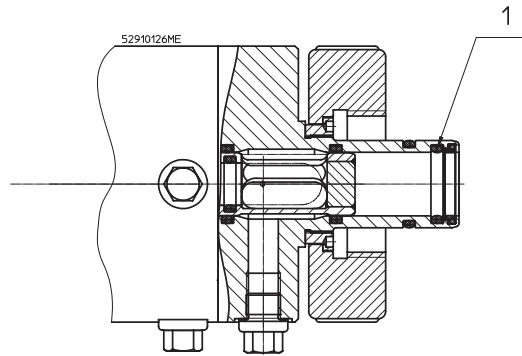

 **Attention:** If the O-ring is removed, process medium can deposit in the open groove. It is therefore necessary to clean this groove regularly.

## 1.5.4 Polymer housings

 **Attention:**

- Retractable housings made of polymer material do not have the same mechanical properties as steel housings.
- Retractable housings made of polymer need more frequent servicing than steel housings.
- Defective components may only be replaced by an authorized service center.

 **Danger!** Polymer housings may not be used in applications subject to high mechanical stress, as this could lead to collapse of the protective caging. In such case, process liquid would be able to access the flushing chamber, resulting in process medium mixing with cleaning medium.

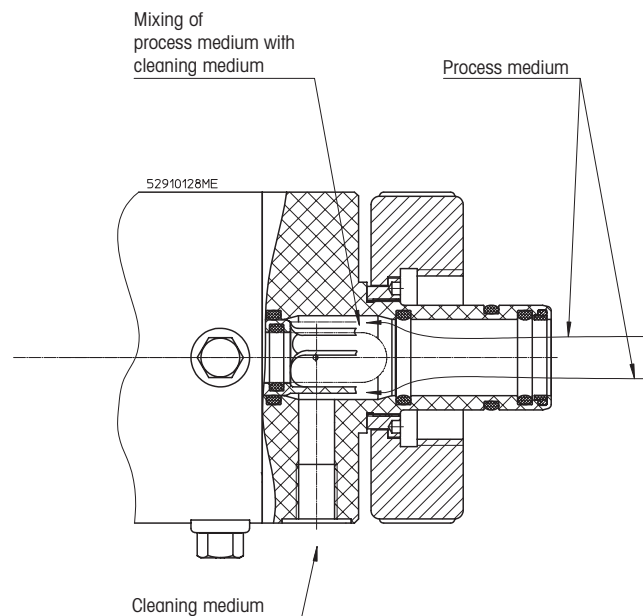

## 1.5.5 Installation in pressurized systems



**Attention:** The maximum permissible temperature and pressure specifications must not be exceeded. The values depend upon the design and type of the retractable housing. The relative specifications are given on the type plate of the individual housings.



**Danger!** If temperature and pressure limits are exceeded, there is a risk to the integrity of the system, thereby presenting a potential threat to human life and to the environment.

Housing	Wetted Material	Max. permissible pressure [PS]/[TS] (linear decreasing for polymer housings)	
InTrac 776 e	PP	6 bar / 20 °C	87 psig / 68 °F
		0 bar / 80 °C	0 psig / 176 °F
	PVDF/PEEK	6 bar / 20 °C	87 psig / 68 °F
		1 bar / 110 °C	15 psig / 230 °F
	DIN 1.4404/AISI 316L, DIN 2.4602/AISI Alloy C22, Ti	6 bar / 130 °C	87 psig / 266 °F
InTrac 77Xe/79Xe	PP	6 bar / 20 °C	87 psig / 68 °F
		0 bar / 80 °C	0 psig / 176 °F
	PVDF/PEEK	6 bar / 20 °C	87 psig / 68 °F
		1 bar / 10 °C	15 psig / 230 °F
	DIN 1.4404/AISI 316L, DIN 2.4602/AISI Alloy C22, Ti	16 bar / 140 °C	232 psig / 284 °F

## 1.5.6 Installation in potentially explosive areas (hazardous areas)



**Attention:**

- Please consult and follow the drawings and diagrams supplied with the measuring system.
- It should be considered to include the METTLER TOLEDO retractable housing InTrac 7XXe and the process connections in your recurring pressure test program for the complete plant as a whole.
- Before the retractable housing is put into operation, the operator must have already clarified beyond doubt that use of the housing in conjunction with the other associated equipment and resources is fully authorized.
- The guide ring (see drawing Pos. 1) must be refitted in good condition each time after maintenance.
- The retractable housing InTrac 7XXe and the process connections must be connected to the main potential equalization system of the plant (grounded).
- In special applications, the minimum conductivity of the medium (in contact with the housing wetted part) shall be more than 1nS/cm.

The grounding cable (see drawing Pos. 2) has to be installed by the operator.



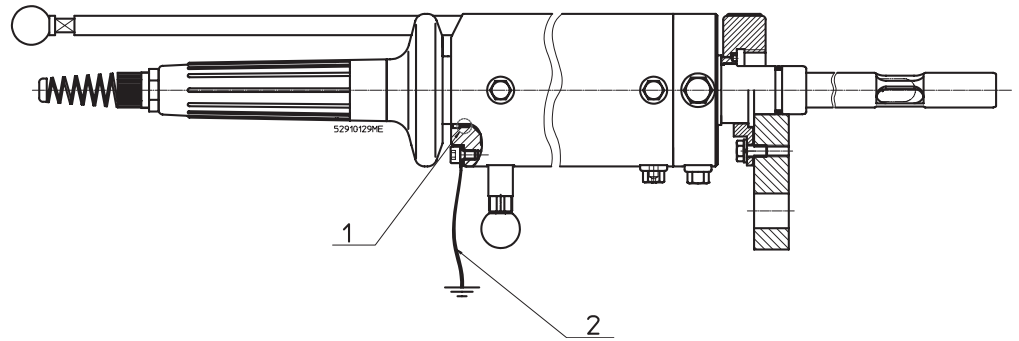

**!** **Danger!** Non-observance of legal regulations concerning use in hazardous areas can endanger human life and the environment.

**☞** **Attention:** See also Chapter 2 "Important notes for housing uses in Ex-Classified area" on page 21.

## 1.6 Residual hazards

**☞** **Attention:** Despite all precautionary measures taken, residual hazards still remain.

### 1.6.1 Rupture of pneumatic or hydraulic connections

**!** **Danger!** The escape of aggressive medium can present a threat to human life and to the environment.

### 1.6.2 Leaky connections

- Connections can become loosened through the effects of vibration.
- The connection between housing and process adaptor is a potential source of leakage.

**☞** **Attention:** The connections between the housing and the process adaptor must be checked regularly by the customer/operator, and kept in full working condition.

**!** **Danger!** Leaky connections can allow process medium, cleaning solution or control (compressed) air to escape to the environment, presenting a hazard for persons and the environment.

### 1.6.3 Malfunctions in overriding control and safety systems

**☞** **Attention:** Problems occurring in the overriding control system can trigger off uncontrolled insertion and retraction of the housing. This can in turn lead to a complete breakdown or malfunctioning of the safety devices.

## 1.6.4 Electricity or control (compressed) air failure



### Attention:

- If there is power failure, information as to the end positions of the housing is no longer available via the inductive position indication system.
- In addition, the overriding control system receives no reliable information concerning exact positioning.
- If the control (compressed) air fails, it is possible that the retractable member (immersion tube) will not reach the required end position.



**Danger!** Before commencing any maintenance work on or removing an electrode/sensor from a housing it is essential to visually check whether the housing is in the "Maintenance", "Measuring", or any undefined intermediate position. The retractable member (immersion tube) must always be stationed in one of the two defined positions:

- "Measuring" (operating) position, that is, in the fully inserted position.
- "Maintenance" (withdrawn) position, that is, in the fully retracted position.

If the retractable member comes to rest or is stuck between the defined "IN" or "OUT" positions, then no conforming measuring results can be ensured.



**Danger!** The electrode/sensor may only be removed when the housing is in the "Maintenance" position, as otherwise there is a risk that process medium could escape to the environment.

This can present a potential hazard to persons, environment and material. Toxic or aggressive media can pose a threat to human life through poisoning, chemical burns or scalding.

## 1.6.5 Medium residues



**Danger!** When retracting the immersion tube from the process, small quantities of process medium will remain attached to the electrode/sensor and will thus enter the flushing chamber. If this medium is a toxic or environmentally damaging substance, or contains pathogenic germs, then such contamination must be removed and disposed of in accordance with regulations!



**Danger!** If the housing is not completely inserted into the process, there will be a path for the process medium to enter the flushing chamber (due to the O-ring). This can lead to product loss or contamination.

## 1.6.6 Manually operated housings





**Danger!** The electrode or sensor may only be removed when the housing is in the "Maintenance" position. Note that the housing InTrac 776e is not equipped with the positive position rod which hinders removal of the electrode/sensor in other than the "Maintenance" position of the housing.



**Danger!** In the case of the manually operated InTrac 7XXe, the retractable immersion tube can be pushed out of the process at an increased velocity by the process pressure.

## 1.6.7 Pneumatically operated housing

 **Attention:** In the case of the pneumatically operated InTrac 7XXe, failure of the compressed air supply can result in the immersion tube being pushed out into the "Maintenance" position by the process pressure. This makes continuous measurement impossible.

 **Danger!** The electrode or sensor may only be removed when the housing is in the "Maintenance" position. Note that the housing InTrac 776e is not equipped with the positive position rod that hinders removal of the electrode/sensor in other than the "Maintenance" position of the housing.

 **Danger!** Before the electrode/sensor is loaded into the pneumatic version of the InTrac 7XXe, it must be ensured that the pneumatic valves that control the position of the housing are set to the "Maintenance" position. Incorrect setting can cause the housing to insert into the process before the loading procedure has been completed, resulting in open access to the process medium. Process medium can thereby escape and present a potential hazard both to persons and to the environment.

## 1.6.8 Heat protection

 **Danger!** The housing is not equipped with heat protection. During steam-sterilization procedure, the surface of the housing can reach high temperatures and cause burns.

## 1.6.9 External influences

 **Attention:** Objects falling on the housing can damage or destroy the unit, or cause leaks etc.

 **Attention:** Lateral forces may damage or destroy the unit.

## 1.7 Emergency measures

 **Attention: Always observe and comply with local regulations!**

 **Attention:** If the retractable housing has been in operation in conjunction with the automated cleaning and calibration system EasyClean, it must be ensured that before any manipulations at the housing, the EasyClean system has been completely switched off and isolated (power, compressed air and water).

## 1.8 Safety measures



**Attention:** Always observe and comply with local laws and regulations!  
These are not an integral part of this Instruction Manual.



**Danger!** It is principally necessary to wear protective equipment such as protective goggles and protective clothing.



**Attention:** The operator is responsible for the instruction of personnel. Additional copies of this Instruction Manual can be ordered from the equipment supplier. As an integral part of the retractable housing, this Instruction Manual must at all times be readily accessible to users at the point of operation of the housing.

The operator is obliged to inform the supplier/manufacturer of the retractable housing immediately about any safety-relevant incidents, or observations made, during use of the housing.



**Danger!** Incorrect manipulation and/or instruction errors can lead to potential hazards for persons and for the environment.



**Attention:** Before every start-up, the retractable housing must be checked for:

- damage to the connections, fastenings, etc.
- leakage
- defective cables and lines etc.
- authorization for use of the housing in conjunction with the associated plant resources.



**Danger!** A defective housing must never be installed or put into operation. Poor containment, leaky connections etc. or non-compliant installation of the housings can lead to escape of process medium and thereby to a potential threat to life (incl. risk of explosion.).

## 1.9 Modifications



**Attention:** No attachments or modifications to the retractable housings are allowed.



**Danger!** The manufacturer/supplier accepts no responsibility for any damage caused by unauthorized attachments and alterations or for the incorporation of spare parts which are not of METTLER TOLEDO provenance. The risk is borne entirely by the operator.

## 2 Important notes for housing uses in Ex-Classified area

### 2.1 Notes on operating instructions

These operating instructions contain all the information needed for safe and proper use of the housing.



The operating instructions are intended for personnel entrusted with the operation and maintenance of sensors and housings. It is assumed that these persons are familiar with the equipment in which the sensors and housings are installed.

#### Warning notices and symbols

See Chapter 1.3 "Warning notices and symbols" on page 11

### 2.2 Intended use

**The retractable housings InTrac 7XXe are intended solely for measurement tasks in conjunction with the specified METTLER TOLEDO electrodes/sensors, namely pH and redox (ORP) combination electrodes as well as oxygen, CO<sub>2</sub>, conductivity or turbidity sensors. Use the housings only for this purpose.**

Housings with the  or  symbol on the type plate have received approval for operation in potentially explosive/hazardous areas.

Any use of these housings which differs from or exceeds the scope of use described in this instruction manual will be regarded as inappropriate and incompatible with the intended purpose. The manufacturer/supplier accepts no responsibility whatsoever for any damage resulting from such improper use. The risk is borne entirely by the user/operator.

Other prerequisites for appropriate use include:

- Compliance with the instructions, notes and requirements set out in this instruction manual.
- Correct maintenance of the housings.
- Acceptance of responsibility for regular inspection, maintenance and functional testing of all associated components, also including compliance with local operational and plant safety regulations.
- Operation in compliance with prevailing regulations concerning the environmental and operating conditions as well as with the admissible mounting positions.
- Compliance with all information and warnings given in the documentation relating to the products used in conjunction with the housings.
- Correct equipment operation in conformance with the prescribed environmental and operational conditions, and admissible installation positions.
- Consultation with METTLER TOLEDO Process Analytics in the event of any uncertainties.



**Danger!** The housing must be operated only with the specified electrodes/sensors. The absence or the installation of an inappropriate electrode/sensor may adversely affect the resistance to pressure and temperature, the chemical resistance and the protection against explosion. Consequently, there can be leakage from the housing and/or risk of explosion that may endanger persons and the environment.

## 2.3 Safety instructions

- The plant operator must be fully aware of the potential risks and hazards attached to operation of the particular process or plant. The operator is responsible for correct training of the workforce, for signs and markings indicating sources of possible danger, and for the selection of appropriate, state-of-the-art instrumentation.
- It is essential that personnel involved in the commissioning, operation or maintenance of these housings or of any of the associated equipment (e.g. sensors, transmitters, etc.) be properly trained in the process itself, as well as in the use and handling of the associated equipment. This includes having read and understood this instruction manual.
- The safety of personnel as well as of the plant itself is ultimately the responsibility of the plant operator. This applies in particular in the case of plants operating in hazardous zones.
- The housings and associated components have no effect on the process itself and cannot influence it in the sense of any form of control system.
- Maintenance and service intervals and schedules depend on the application conditions, composition of the sample media, plant equipment and significance of the safety control features of the measuring system. Processes vary considerably, so that schedules, where such are specified, can only be regarded as tentative and must in any case be individually established and verified by the plant operator.
- Where specific safeguards such as locks, labels, or redundant measuring systems are necessary, these must be provided by the plant operator.
- A defective housing must neither be installed nor put into service.
- Only maintenance work described in these operating instructions may be performed on the housings.
- When changing faulty components, use only original spare parts obtainable from your METTLER TOLEDO supplier (see spare parts list, Chapter 8.2 "Spare parts list" on page 66).
- No modifications to the housings and the accessories are allowed. The manufacturer accepts no responsibility for damage caused by unauthorized modifications. The risk is borne entirely by the user.
- Care must be taken during installation to avoid impacts or friction that could create an ignition source.
- Tampering and replacement with non-factory components may adversely affect the safe use of the system.
- Insertion or withdrawal of removable electrical connectors or modules is to be accomplished only when the area is known to be free of flammable vapors.
- **WARNING** – INTRINSICALLY SAFE APPARATUS CAN BE A SOURCE OF IGNITION IF INTERNAL SPACINGS ARE SHORTED OR CONNECTIONS OPENED.
- **WARNING** – DO NOT OPEN WHEN AN EXPLOSIVE ATMOSPHERE IS PRESENT.
- **WARNING** – SUBSTITUTION OF COMPONENTS MAY IMPAIR INTRINSIC SAFETY.
- **WARNING** – SUBSTITUTION OF COMPONENTS MAY IMPAIR SUITABILITY OF THE EQUIPMENT
- **WARNING** – FOR CONNECTION ONLY TO NON-FLAMMABLE PROCESSES.

## 2.4 Correct disposal of the housing

When the housing is finally removed from service, observe all local environmental regulations for proper disposal. See Chapter 9 "Decommissioning, storage, disposal" on page 67.

## 2.5 Use in Ex-zones



### ATTENTION!

For an installation in Ex-zones please read the guide-lines following hereafter:



#### Ex-classification ATEX:

- ⊗ II 1/2G c IIC TX Ga/Gb
- ⊗ II 1/2D c IIIC TX Da/Db

#### Number of the test certificate:

SEV 13 ATEX 0161X

#### Ex-classification FM approved:



IS/I,II,III/1/ABCDEFG/T6 Ta = 60 °C  
- 53 800 002; Entity

Project ID: 3021227

FM certificate number: FM16US0034X  
FM18CA0021X

## 2.6 Ex-classification ATEX

### 2.6.1 Introduction

According to RL 94/9/EG (ATEX 95) Appendix I, InTrac 7XX/\*1/\*2/\*3/\*4/\*5/\*6\*7\*8 housings are devices group II, category 1/2G and according to RL 99/92/EG (ATEX 137) may be used in zones 0/1 or 0/2 and gas group IIC that are potentially explosive due to combustible substances in the temperatures classes T3 to T6.

For use/installation, the requirements of EN 60079-14 must be observed.

According to RL 94/9/EG (ATEX 95) Appendix I, InTrac 7XX/\*1/\*2/\*3/\*4/\*5/\*6\*7\*8 housings are devices group III, category 1/2D and according to RL 99/92/EG (ATEX 137) may also be used in zones 20/21 resp. 20/22 that contain combustible dusts.

For use/installation, the requirements of EN 50281-1-2 must be observed.

The pneumatically operated housings with electrical (inductive) position indication of the probes may be employed in hazardous areas, Zone 1 and Zone 2 resp. Zone 21 and Zone 22, also in conjunction with separately certified, intrinsically safe, inductive proximity switches – e.g.

Pepperl+Fuchs, Types NCB2\*\*\* – on condition that the applicable Gas Groups and Temperature Classes correlate with the actual inflammable materials present, and that the special conditions of the declaration are strictly adhered to.

## 2.6.2 Special conditions

The housings with pneumatic actuation position of the sensors with electrical feedback signal may be operated in hazardous areas Zone 1 and Zone 2 or Zone 21 and Zone 22 with separately certified intrinsically safe inductive proximity switches e.g. Pepperl + Fuchs types NCB2\*\*\*– if the gas groups and temperature classes coincide with the used flammable substances and the special conditions of the Certificates are observed.

1. The maximum permissible ambient or process temperatures for Zone 0 (flammable gases or flammable liquids) shall be taken according to the following table:

Temperature class	Max. environment resp. media temperature
T6	68 °C
T5	80 °C
T4	108 °C
T3	130 °C

The maximum permissible ambient or process temperatures must not exceed the aforementioned values and they will be found in Chapter 8 "Product specifications" on page 62.

2. The maximum permissible surface temperature for Zone 20 (combustible dust) shall be taken accordingly to the following table:

Temperature class	Max. environment resp. media temperature
T 69 °C	68 °C
T 81 °C	80 °C
T 109 °C	108 °C
T 131 °C	140 °C

The maximum permissible ambient or process temperatures must not exceed the aforementioned values and they will be found in Chapter 8 "Product specifications" on page 62.

3. The metallic body of the housing type InTrac 7XX\*1/\*2/\*3/\*4/\*5/\*6/\*7/\*8 has to be connected conductively to the equipotential system of the plant.
4. The housings type InTrac 7XX\*1/\*2/\*3/\*4/\*5/\*6/\*7/\*8 are included in the periodic pressure testing of the system, where appropriate
5. **WARNING** – POTENTIAL ELECTROSTATIC CHARGING HAZARD – by installation, use and maintenance work, see instruction manual



## 2.7 Ex-classification FM approved



IS/I,II,III/1/ABCDEFG/T6 Ta = 60 °C

### 2.7.1 Introduction

The following FM control drawing and the standards listed in Chapter 2.7.3 "Applied standards" on page 26 must be observed, where applicable:

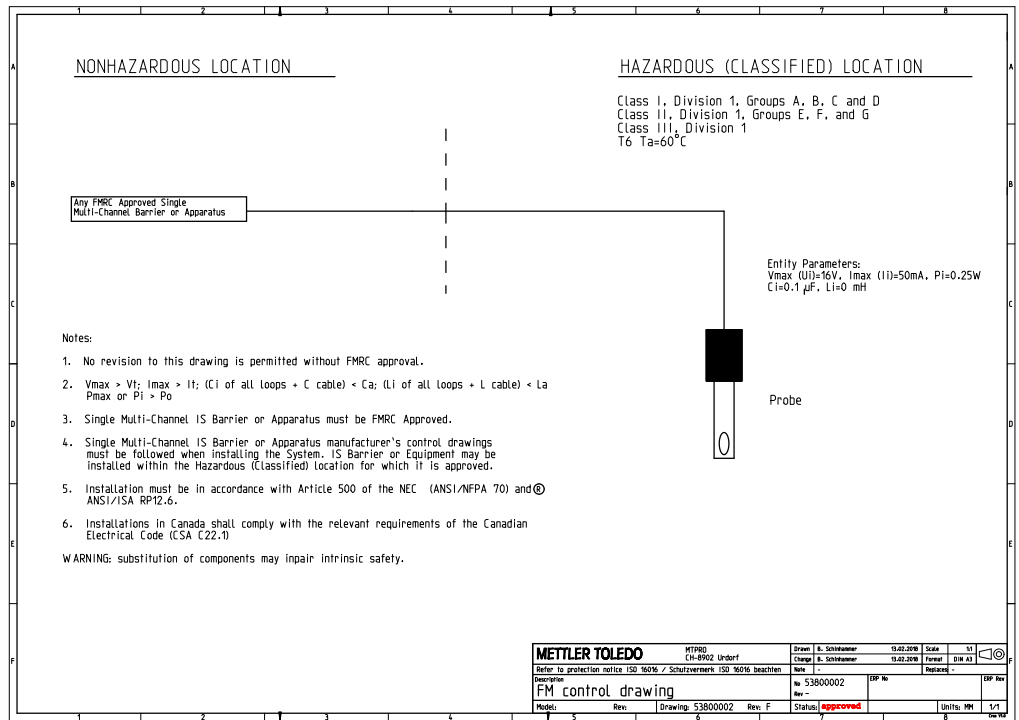

## 2.7.2 Special conditions

See Chapter 2.6.2 "Special conditions" on page 24.

## 2.7.3 Applied standards

### United States Standards

Title	Number	Issue Date
Approval Standard for Electrical Equipment for Use in Hazardous (Classified) Locations – General Requirements	FM Class 3600	2011
Approval Standard for Intrinsically Safe Apparatus and Associated Apparatus for Use in Class I, II & III, Division 1, Hazardous (Classified) Locations	FM Class 3610	2015
Approval Standard for Electrical Equipment for Measurement, Control and Laboratory Use	FM Class 3810	2005
Explosive Atmospheres – Part 0: Equipment – General Requirements	ANSI/ISA-60079-0 (12.00.01)	2005
Explosive Atmospheres – Part 11: Equipment Protection by Intrinsic Safety "i"	ANSI/ISA-60079-11 (12.02.01)	2009
Safety Requirements for Electrical Equipment for Measurement, Control, and Laboratory Use – Part 1: General Requirements	ANSI/ISA-61010-1 (82.02.01)	2004

### Canadian Standards

Title	Number	Issue Date
Explosive Atmospheres – Part 0: Equipment – General Requirements	CAN/CSA-C22.2 No. 60079-0	2005
Explosive Atmospheres – Part 11: Equipment Protection by Intrinsic Safety "i"	CAN/CSA-C22.2 No. 60079-11	2009
Safety Requirements for Electrical Equipment for Measurement, Control, and Laboratory Use – Part 1: General Requirements	CAN/CSA-C22.2 No. 61010-1	2004

## 3 Product descriptions

---

### 3.1 Scope of delivery

Standard supply of the retractable housing is made up of the following:

– **Manually operated (M) version**

Retractable housing finished assembled in accordance with description in order confirmation:

- cable grommet
- positive position rod, (except for InTrac 776e)
- Instruction manual and a quick setup guide
- Logbook
- certificates in line with the specifications

– **Pneumatically operated (P) version**

Same as for manually operated version, additionally with 2 pcs. screw-connections (throttle valve) for the pneumatics, but without lines/hoses.

– **Pneumatically operated version with pneumatic position indication system (R)**

Same as for pneumatically operated version, additionally with 2 pcs. 3/2-way valves, but without lines/hoses

– **Pneumatically operated version with inductive position indication system, non-Ex (I) design**

Same as for pneumatically operated version, additionally with 2 pcs. inductive proximity switches, non-Ex.

– **Pneumatically operated version with inductive position indication system, Ex-proof (X) design**

Same as for pneumatically operated version, additionally with 2 pcs. inductive proximity switches Ex.

**For InTrac 776e additionally:**

- pneumatic connection set
- bicycle pump
- syringe for topping up electrolyte

### 3.2 Packing

The packing consists of cardboard and foam plastic.

Keep the packing for possible later use, such as for storage or transport of the housing. However, if you wish to dispose of the packing, please observe your local regulations in this respect.



**Attention:** see Chapter 9.3 "Disposal" on page 67.

### 3.3 Checking the shipment

When unpacking the shipment, examine carefully for signs of damage. Any damage noted must be reported immediately to the carrier and your supplier.

Check that the shipment accords to the delivery papers and to your order.



**Attention:** Damaged housings must not be installed or put into operation.

### 3.4 Product overview

The retractable housings are available in different versions, depending on:

- which type of electrode/sensor is to be employed
  - **InTrac 776 e:** for pH/redox (ORP) electrodes with liquid electrolyte
  - **InTrac 777 e/797 e:** for pH/redox (ORP) electrodes with solid (polymer) or gel electrolyte, Ø 12 mm O<sub>2</sub>- and CO<sub>2</sub> sensors as well as Ø 12 mm conductivity sensors
  - **InTrac 779 e/799 e:** for turbidity sensors

A list of the suitable electrodes/sensors can be found in the relative Appendix to this Manual.

- Operating modes:
  - **M** = manually operated version
  - **P** = pneumatically operated version
  - **R** = pneumatically operated version with pneumatic indicators
  - **I** = pneumatically operated version with inductive indicators, non-Ex
  - **X** = pneumatically operated version with inductive indicators, Ex-proof
- Immersion depth ("H")
  - **70 mm**
  - **100 mm**
  - **200 mm**

Exact dimension illustrations of all housings are to be found in the relative Appendix to this Manual.
- Medium-wetted materials
 

Metal varieties:



  - **stainless steel DIN 1.4404/AISI 316 L**
  - **DIN 2.4602/AISI Alloy C22 (e.g. Hastelloy)**
  - **titanium**

Polymer varieties:

  - **PP**
  - **PVDF**
  - **PEEK**
- Medium-wetted sealing materials (O-rings)
  - **Viton® -FDA**
  - **EPDM-FDA**
  - **Kalrez®-FDA and USP Class VI**
- Process connections
  - **Weld-in socket (METTLER TOLEDO Ø 25 mm),**
  - **Flange attachments (DIN, ANSI)**
  - **NPT external thread**
  - **TriClamp**
  - **Tuchenhagen Varivent**

The exact version of the housing can be seen from the type designation on the housing.

Example: **InTrac 777P/070/4404/D00/Vi/A00**

 **Attention:** Retractable housings approved for operation in hazardous areas additionally bear the symbol  or  on the type plate. Housings without this additional marking on the type plate are not authorized for use in hazardous areas.

A full key to the markings is to be found in the relative Appendix of this Instruction Manual.

## 3.5 Construction of the retractable housings

### 3.5.1 Operating modes of the retractable housings

Each version of the retractable housing family InTrac 7XXe is available in five different types (**M, P, R, I** and **X**):

- **M** Manually operated version

**InTrac 797 M**



**InTrac 776 M**



**InTrac 777 M**

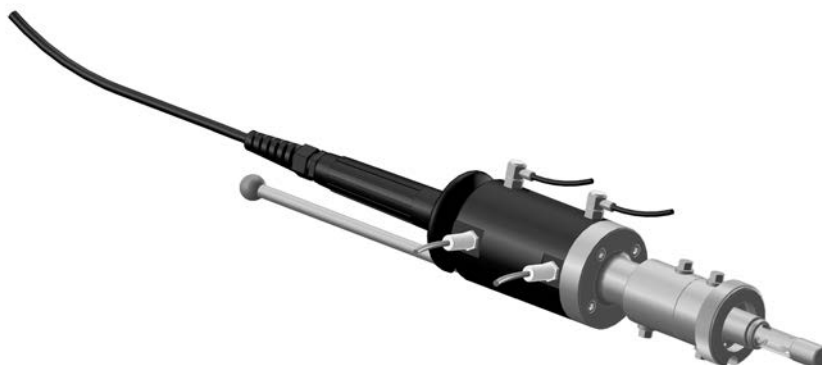

- **I and X** pneumatically operated versions with inductive position indicators, non-Ex and Ex-proof

**InTrac 797 I****InTrac 776 I****InTrac 777 I**

**Attention:** pneumatically operated versions can also be supplied with a pneumatic position indication system (**type R**) or without position monitoring (**type P**).

### 3.5.2 Lower part of housing for process adaption

#### Process adaption via ring nut on DN25 socket

Steel variety for  
InTrac 776e / 777e / 779e

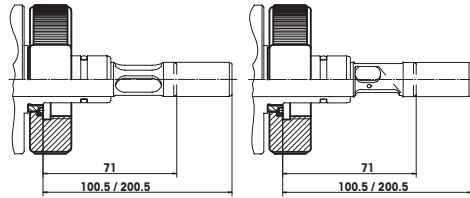

Steel variety for  
InTrac 797e / 799e

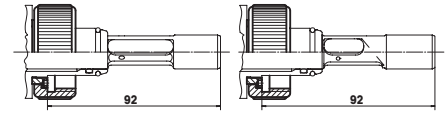

Polymer variety for  
InTrac 776e / 777e

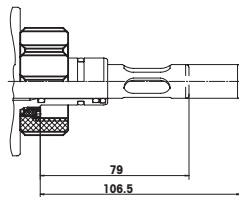

#### Process connection via DIN flange

Steel variety for  
InTrac 776e / 777e / 779e

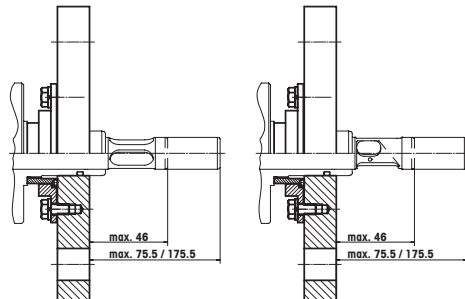

Variety DIN 2.4602, Ti for  
InTrac 776e / 777e / 779e

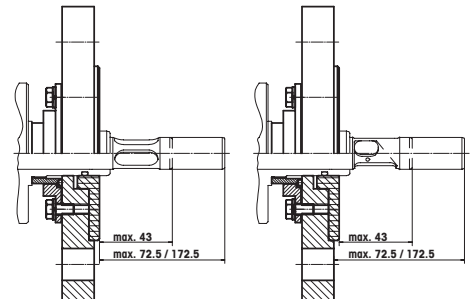

Polymer variety for  
InTrac 776e / 777e

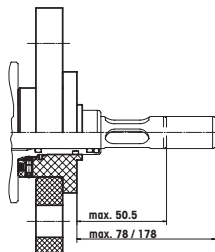

### Process connection via ANSI flange

Steel variety for  
InTrac 776e / 777e / 779e

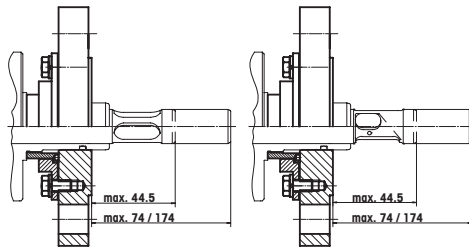

Variety DIN 2.4602, Ti for  
InTrac 776e / 777e / 779e

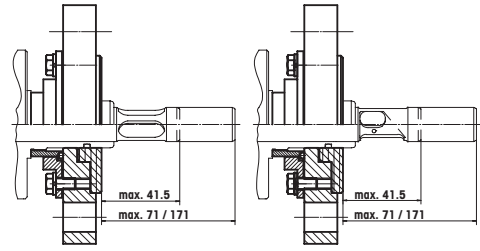

Polymer variety for  
InTrac 776e / 777e

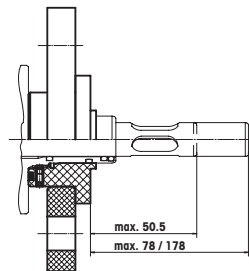

### Process connection via NPT thread

Steel variety NPT 1" / 1 1/4" for  
InTrac 776e / 777e / 779e

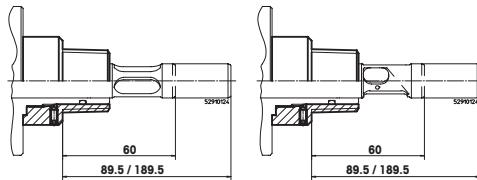

Steel variety NPT 1 1/2" for  
InTrac 776e / 777e / 779e

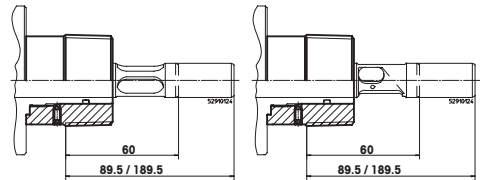

Polymer variety for  
InTrac 776e / 777e

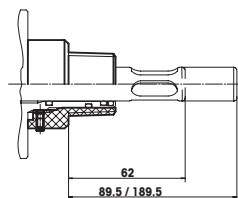



**Process connection via Tri-Clamp**

Steel variety for  
InTrac 776e / 777e / 779e

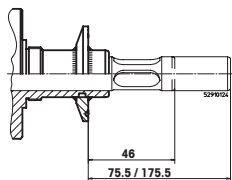
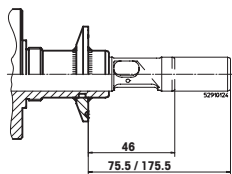

Steel variety for  
InTrac 797e / 799e

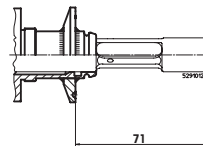
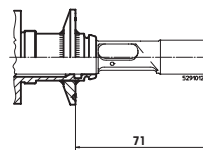

**Process connection via Tuchenhagen Varivent DN50**

Steel variety for  
InTrac 776e / 777e / 779e

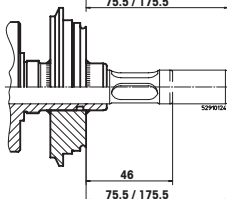
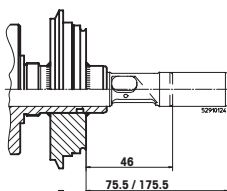

Steel variety for  
InTrac 797e / 799e

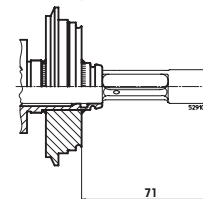
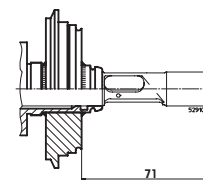

## 3.6 Description of function of retractable housings

With the retractable housings InTrac 7XXe, electrodes/sensors can be cleaned or replaced without interrupting the ongoing process. In addition, with the aid of auxiliary equipment (EasyClean) it is possible to calibrate or sterilize (double flushing chamber version) the measurement system with the electrode/sensor installed.

### 3.6.1 Manually operated versions

For manual versions, the immersion tube is moved into the desired end position, "Measuring" position or "Maintenance" position, by hand after releasing the locking pin "B" (see drawing) by pulling out the red knob.



**Attention:** The housings are equipped with a mechanical sensor detector. If no electrode/sensor has been fitted in the housing, it is not possible to move the housing ("B"). The housing remains in a locked position.

#### "Measuring" position of manual versions

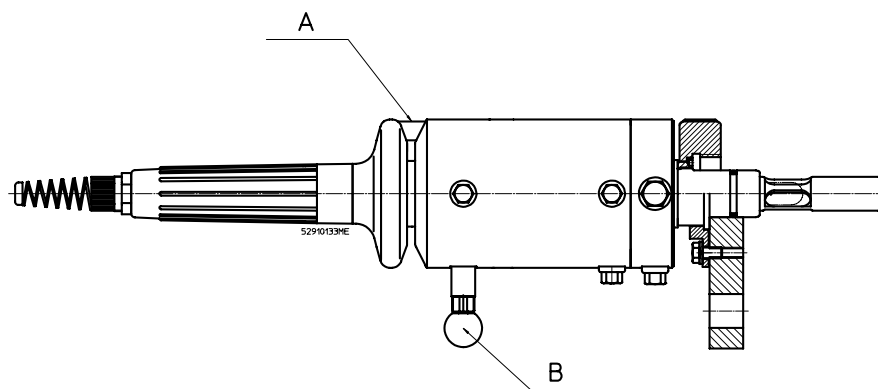

In the "Measuring" position, the immersion tube is fully inserted. The process medium flows past the tip of the electrode/sensor through the openings at the end of the immersion tube. O-rings seal the housing against ingress of process medium.

In the "Measuring" position, the locking pin "B" must latch into the groove of the immersion tube. In the case of the housings InTrac 7X7e and InTrac 7X9e, the positive position rod "A" must engage in the handle (protective sleeve) of the housing (see drawing). To do this, rotate the immersion tube clockwise until the positive position rod "A" distinctly engages. The housing InTrac 776e does not have a positive position rod.

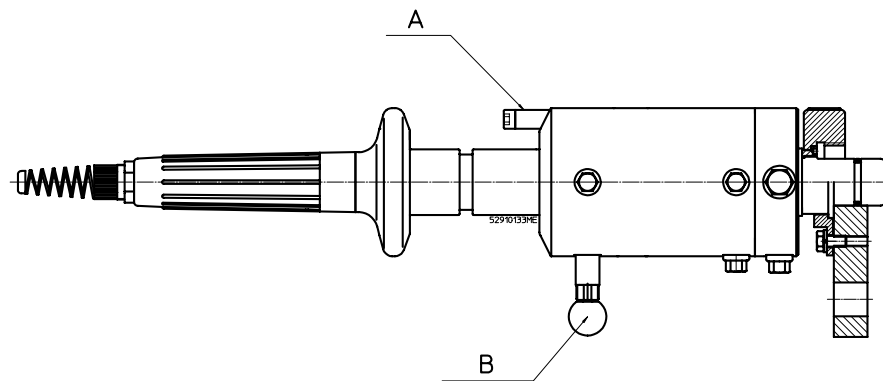
**"Maintenance" position of manual versions**

In the "Maintenance" position, the electrode/sensor can be cleaned or removed/exchanged, or the complete measuring system calibrated with the electrode/sensor installed. O-rings seal the housing against ingress of process medium.

In the "Maintenance" position, the locking pin **"B"** (see drawing) must snap into the hole in the piston (see Pos. C on the drawing).

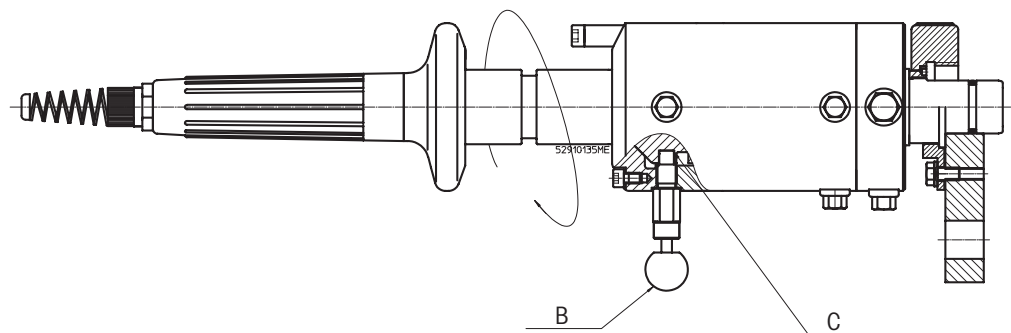

### Use of the positive position rod (anti-twist safety device)

In the case of the housings InTrac 7X7 e and InTrac 7X9 e, the positive position rod included with the supply can be screwed into place instead of the standard short positioning pin. This reduces the risk of any unintentional, incorrect manipulation of the electrode/sensor when the housing is inserted in the "Measuring" position, and, at the same time, prevents the immersion tube from being twisted out of its optimal path of motion during insertion and retraction.

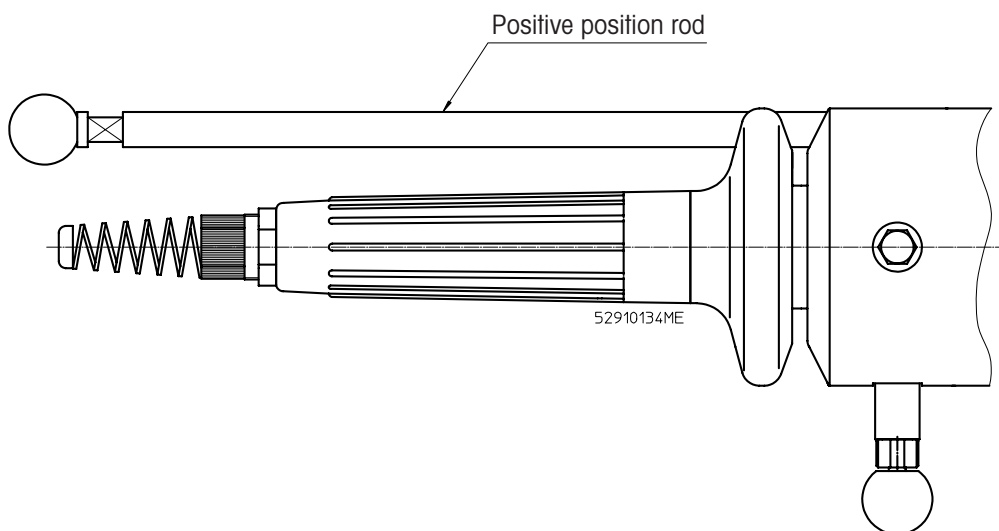

**Danger!** If the immersion tube comes to rest in an undefined position, this can lead to blockage of the inlet or outlet of the flushing chamber(s), and the flow of cleaning and flushing medium to the sensor will be impaired.

### 3.6.2 Pneumatically operated versions

The compressed air connections are used to pressurize the piston of the immersion tube either from above or from below. This allows the immersion tube and hence the electrode/sensor to be moved either downwards (into the "Measuring" position) or upwards (into the "Maintenance" position). The piston remains pressurized with compressed air at the respective end position.

In housing versions equipped with a position indication system, a pneumatic or inductive signal is triggered when the immersion tube is in the respective end position ("Measuring" or "Maintenance"). This signal is transmitted to a remote indicator (latter not included in housing supply).



**Attention:** The insertion and retraction speed of the immersion tube can be set as desired by means of the adjustment screw on the throttle valve and by adjustment of the air supply pressure.

### “Measuring” position of pneumatic versions

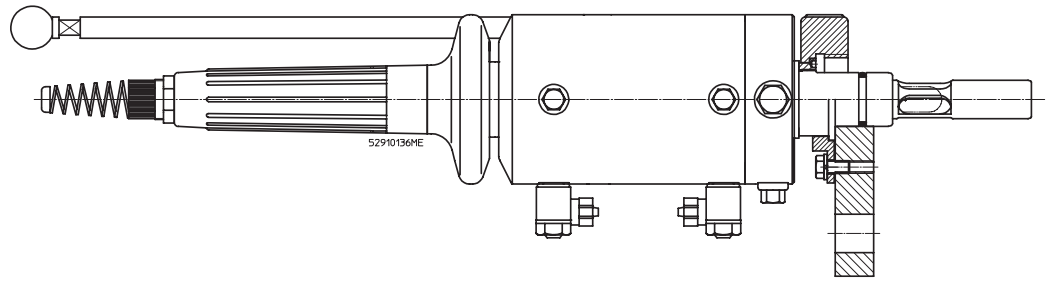

In the “Measuring” position, compressed air pressurizes the immersion tube piston from above. The process medium flows past the tip of the electrode/sensor through the openings at the end of the immersion tube. O-rings seal the housing against ingress of process medium.

### “Maintenance” position of pneumatic versions

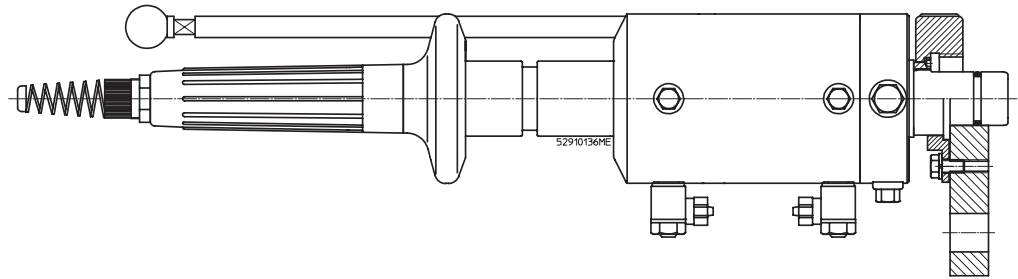

In the “Maintenance” position, compressed air pressurizes the immersion tube piston from below. In this position, the electrode/sensor can be cleaned or removed/exchanged, or the complete measuring system calibrated with the electrode/sensor installed. O-rings seal the housing against ingress of process medium. The housings are equipped with a pneumatic sensor detection system.



**Attention:** If no electrode/sensor is installed or it is incorrectly fitted, the housing will not move to the “Measuring” position or the unit will leak.



**Danger!** Process medium can present a hazard to human life and to the environment.

### Use of the positive position rod (anti-twist safety device)

In the case of the housings InTrac 7X7 e and InTrac 7X9 e, the positive position rod included with the supply can be screwed into place instead of the standard short positioning pin. This reduces the risk of any unintentional, incorrect manipulation of the electrode/sensor when the housing is inserted in the "Measuring" position, and, at the same time, prevents the immersion tube from being twisted out of its optimal path of motion during insertion and retraction.



**Attention:** If the housing is used in conjunction with the EasyClean system, the anti-twist safety device (the positive position rod) must be used, as otherwise cleanability of the electrode/sensor in the flushing chamber cannot be carried out with optimal effect.



**Danger!** If the immersion tube comes to rest in an undefined position, this can lead to blockage of the inlet or outlet of the flushing chamber(s), and the flow of cleaning and flushing medium to the electrode/sensor will be impaired.

## 4 Installation and start-up

### 4.1 Preparation of the equipment

The retractable housings are mounted and fixed on a vessel (reactor, tank, pipe, etc.) either by means of a ring nut in conjunction with a weld-in socket, by a flange connection, or via a NPT external thread.



**Attention:** Attachment of the weld-in socket, flange connection or threaded bushing is the responsibility of the customer.



**Attention:** Weld-in sockets G 1 1/4" (internal  $\varnothing=25$  mm, L=40 mm, straight or 15° inclined) are available from your supplier in a choice of materials.



**Danger!** Our welding instructions (included in the supply of the original METTLER TOLEDO socket) for the weld-in socket must be fully observed, as otherwise the process connection can be untight (leak) or the pressure resistance insufficient.



**Caution!** After welding, the bore of the weld-in socket is to be checked and if necessary reamed to the dimension 25-H7.

In order to guarantee correct function of the retractable housings, please pay attention to the following installation instructions:



- The retractable housing can be mounted vertically or in an inclined position.
- Caution!** In the case of inclined mounting, the angle of the housing must be equal to or greater than 15° above the horizontal.

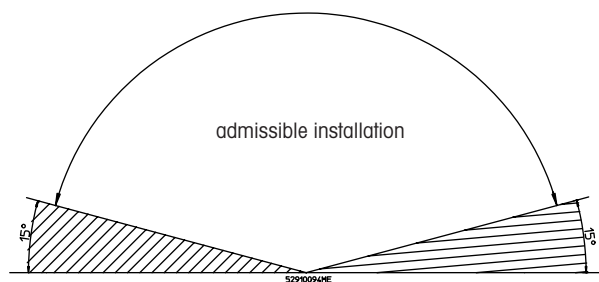

- The retractable housing is to be mounted in such a position that there is always enough clearance available for its correct functioning (correct "Measuring" position in the sample medium) as well as for maintenance work (checks, fitting and removal of the electrodes/sensors). The relative dimensions can be seen on the drawings in the relative Appendix to this Instruction Manual, or in the specifications.
- Mounting of the retractable housing in exposed positions should be avoided. If this is not possible, relative measures to protect against damage or interference must be taken.

## 4.2 Fitting and installation work



**Caution!** In all installation work described below, ensure that the equipment in which the housing is to be installed is in a non-hazardous condition (depressurized, empty, rinsed, vented, etc.).

### 4.2.1 Fitting the housing



**Caution!** Never place or support the housing on the front end of the centering spigot or immersion tube (risk of damage). Ensure that the housing is fitted to the correct, prescribed socket or flange as directed (see Chapter 3.5.2 "Lower part of housing for process adaption" on page 31).

#### 4.2.1.1 Fitting via a weld-in socket

1. Clean the centering spigot of the retractable housing and the bore of the weld-in socket (25-H7), checking for damage.



**Caution!** Fitting of the retractable housing with a damaged spigot or into a damaged weld-in socket is not allowed and can present a hazard to persons and/or lead to material damage.

2. Check the vessel to ensure that there are no obstacles in the insertion direction which could hinder the motion of the immersion tube.
3. Check the O-ring on the spigot for damage and replace it if necessary. Lightly smear the O-ring with grease. Ensure correct quality and positioning of the O-ring.
4. Position the housing on the weld-in socket and carefully insert the spigot into the bore.
5. Finally, tighten the ring nut until the connection is completely sealed.



**Caution!** Checking of the sealing/tightness of the process adaptor is the responsibility of the operator, who must also guarantee same by adopting appropriate measures. Additional safety provisions are necessary if the connection is subject to stress from vibrations.

#### 4.2.1.2 Fitting via a flange

1. Clean the sealing surfaces of the flange (housing and flange connection on vessel) and check for damage.



**Caution!** If the process media/reaction products are considered to be dangerous, it is imperative that an embedded seal is used at the flange interface and/or a splash guard mounted. Fitting of the retractable housing with damaged flange connections is not allowed and can present a hazard to persons and/or lead to material damage.

2. Use the appropriate flange gasket and check for sound condition. Replace if necessary.



**Attention in the case of housings made of special materials:** Check that the seal is present on the flange of the retractable housing and is not damaged. Replace if necessary. Ensure correct quality and positioning of the seal.

3. Check the vessel to ensure that there are no obstacles in the insertion direction which could hinder the motion of the immersion tube.
4. Position the housing on the flange connection, align, and tighten evenly crosswise using the prescribed number of bolts and nuts.



### 4.2.1.3 Fitting via NPT external thread

1. Wind PTFE tape around the external male thread.
2. Screw the housing carefully into the female socket.
3. Check the Installation for leaks.

### 4.2.1.4 Fitting via Tri-Clamp and Varivent flange connection

1. Clean the sealing surfaces of the flange (housing and flange connection on vessel) and check for damage.



**Caution!** If the process media or reaction products are considered to be dangerous, it is imperative that an embedded seal is used at the flange interface and/or a splash guard mounted. Fitting of the retractable housing with damaged flange connections is not permitted and could present a potential hazard to persons and/or lead to material damage.

2. Use the appropriate flange gasket and check for sound condition. Replace if necessary.
3. Check the vessel to ensure that there are no obstacles in the insertion direction which could hinder the motion of the immersion tube.
4. Position the housing on the flange connection, align, and tighten well with the clamp fastener.

### 4.2.2 Attaching the flushing lines (single flushing chamber)



- **Danger!** When retracting the immersion tube from the process, small quantities of process medium will remain attached to the electrode/sensor and will thus enter the discharge line during flushing procedures. If the process medium contains toxic, caustic substances damaging to the environment, then it is imperative to consult local regulations relative to the design and construction of effluent (treatment) installations.
- When constructing the flushing water installation, use only materials which are resistant to corrosion and chemicals.

#### **Consequences of an intermediate, undefined position of the housing, version with immersion depth H = 70 mm**

If during insertion or retraction motion, the immersion tube comes to rest in other than the defined end positions "Measuring" and "Maintenance", process medium can escape to the environment via the flushing chamber and the flushing lines. This could create a hazard for personnel, equipment and the environment.

Recommendations for proper operation and safe use

All flushing lines must be equipped with check valves which may only be opened when the immersion tube is in the retracted position ("Maintenance"). After maintenance work on the sensors, the valves must be closed.

### Basic installation

The basic installation is intended for cleaning/flushing of the electrodes and sensors when the housing is in the "Maintenance" position.

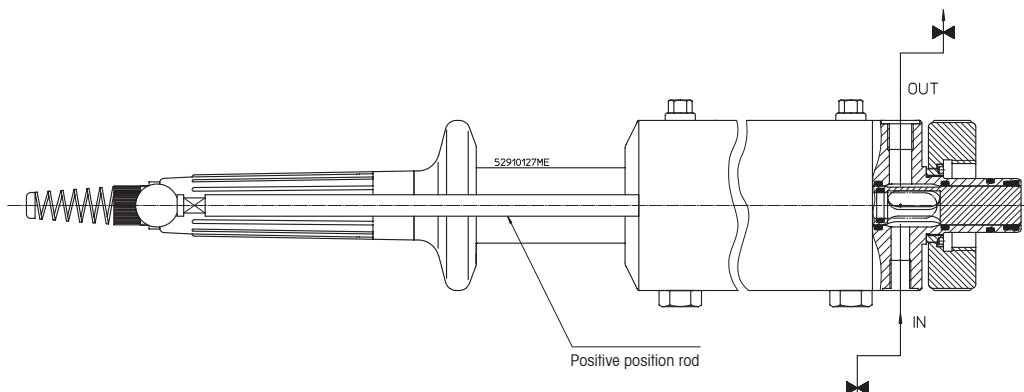

- Inlet:  
The inlet line is connected to the flushing water inlet "IN" (thread G 1/8") of the housing via an appropriate shut-off device.
- Outlet:  
For the water outlet, the flushing water outlet "OUT" (thread G 1/4", and for InTrac 79Xe thread G 1/8") is connected to the appropriate drain (comply with local regulations).



**Attention:** The water outlet should be positioned at a somewhat higher level than the inlet so that the chamber lock is always filled with water or buffer solution even when the inlet is closed. This prevents the pH electrode from drying out. Where necessary, use a suitable lead-off (first upwards) for the outlet line.

### Installation for calibration of the measurement system with electrode/sensor installed

If the measurement system has to be cleaned and/or calibrated with the electrode/sensor installed, a distributor with three connections is attached to the connection (thread G 1/8") of the housing in place of the inlet line.

Make three connections as shown in the following schematic diagram:

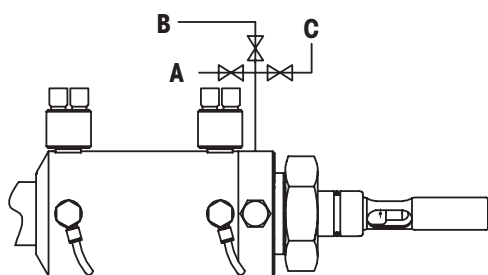

- Connection "A" to the flushing water inlet via a shut-off valve.
- Connections "B" and "C" to the corresponding buffer solution supply, each via a non return valve.

### 4.2.3 Attaching the flushing lines (double flushing chamber)

#### Function of double flushing chamber

The measuring tip of the electrode/sensor can be flushed, serviced (if necessary), and steam-sterilized when the housing is in the retracted "Maintenance" position. In contrast to the single chamber principle, the double chamber arrangement ensures that after sterilization, the lower flushing chamber remains sterile when the electrode/sensor is reinserted into the process. This is because the electrode section which enters the lower flushing chamber during reinsertion into the process has been sterilized in the upper flushing chamber.

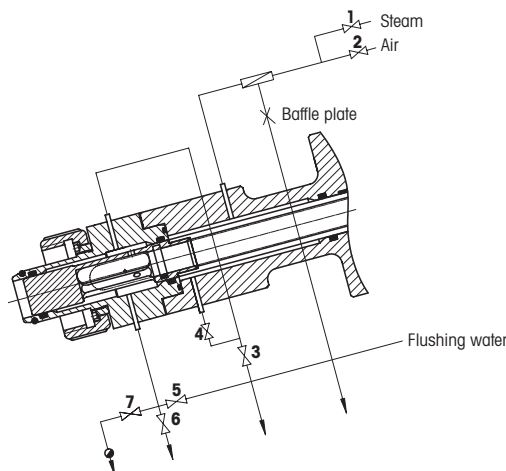

#### Drawing: "Connecting flushing water and air lines"

The recommended steam pressure is 2.2. bars. The valves "3", "5" and "6" must be fitted as near as possible to the T-pieces in order to ensure good heat flow. The baffle plate (aperture 0.5 mm in diameter) in the condensate outlet from the filter spares the use of an additional throttle valve or condensate trap. The flushing water is fed into the lower flushing chamber from the bottom so that air is easily displaced. The upper chamber does not have to be flushed as it remains clean throughout all operation modes. We recommend an air filter with a pore size of 0.2 µm allowing a flow rate of 100 m<sup>3</sup>/h, for instance, the filter type Emflon 2 from Pall (Designation: MCY4463V002PVH4).

#### 1. Sterilization:

The cycle begins with flushing by steam, whereby valves "2", "3", "5", and "7" remain closed and valves "1", "4" and "6" are open until the double chamber lock becomes hot. This is followed by sterilization, with valve "6" closed and valve "7" open.

#### 2. Aeration:

After sterilization, the valves "1" and "7" are closed and valve "2" opened in order to aerate the system during the cooling down from the sterilization temperature.

#### 3. Flushing:

To flush the lower flushing chamber, valves "1", "2", "4", "6" and "7" are closed and valves "3" and "5" open. Residual flushing water can afterwards be blown out by steam (as in point 1 above), or by air, whereby the valves "2", "4" and "6" are open and valves "1", "3", "5" and "7" closed.

**Attention: Connecting the sterilizing and flushing lines**

The housing is supplied with blind plugs in the ports of the rinsing chambers.



**Caution!** It is essential that the two closely adjacent fittings point vertically downwards. Never mount horizontally.

**Safety precautions**

- Stainless steel tube of 6/4 mm (OD/ID) is recommended for the supply and drain lines. Long runs of tubing are not recommended.
- Steam lines should be lagged to protect equipment users from burns, and to prevent undue heat loss.
- It is also desirable to arrange for a supply of sterile air to the flushing chambers. When calibrating the O<sub>2</sub> sensor in the rinsing chamber, it is mandatory to connect a supply of sterile air.

## 4.2.4 Pneumatic-connections

Pneumatically operated housings require compressed air connected to "1" and "2".

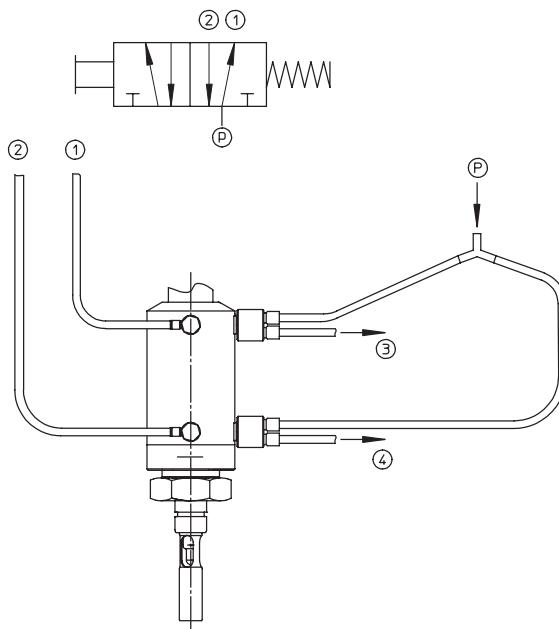
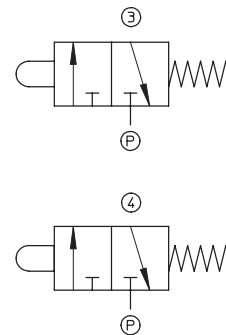

**Caution!** Only the original fittings supplied with the housing may be used. For operation of the housing with a position indicator system, connections "3" and "4" for the position indicator valves must also be connected to the compressed air supply. Link the connections in accordance with the following diagram.

**5/2-way valve**

**3/2-way valve**

- p = Feed  
 1 = Feed "Measuring"  
 2 = Feed "Maintenance"  
 3 = Position indication "Maintenance"  
 4 = Position indication "Measuring"

**Attention:**

- The permitted maximum operating pressure of the pneumatic system is 8 bars.
- The pressure in the control air supply to the housing must reach 4 bars.
- The control air must be dry, oil-free and filtered.

## 4.2.5 Fitting of 3/2-way valve for position indicator

1. Remove blind plug "1"
2. Screw in 3/2-way valve for position indicator
3. Connect the pneumatic lines

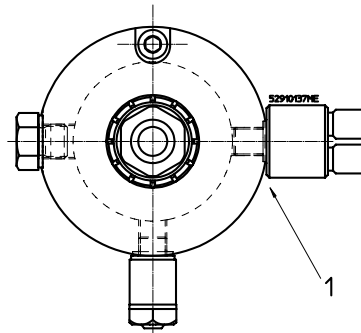

## 4.2.6 Fitting of inductive position indicators (Ex-proof or non-Ex)



**Attention:** Inductive position indicators may only be fitted by the operator during the initial installation of the housing. In case you have to replace position indicators already installed, please contact the nearest authorized service point.

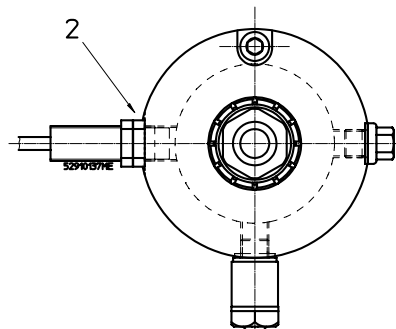

1. Remove blind plug "2"
2. Screw in the indicators fully using Loctite 577 (see figures) and then finally unscrew by 0.5 mm.

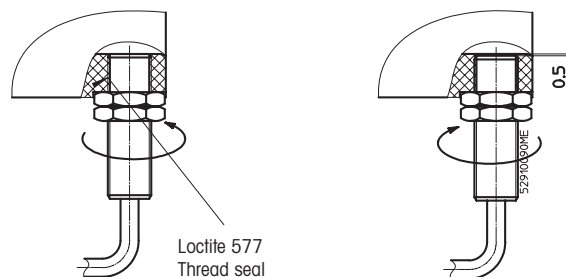

**Danger!** Retractable housings with inductive position indicators of **non-Ex** type are not approved for use in hazardous areas.

## 4.2.7 Installing the temperature sensor

During calibration of the measurement system, the temperature of the electrode/sensor, with exception of the turbidity sensor, must be taken into account. To cover this, a temperature sensor is connected to the transmitter.

For automatic temperature compensation during calibration of the measurement system with an electrode/sensor installed, a temperature sensor (Pt100/Pt1000) should be incorporated directly in the lock chamber. Carry out installation of the Pt100/Pt1000 as follows:

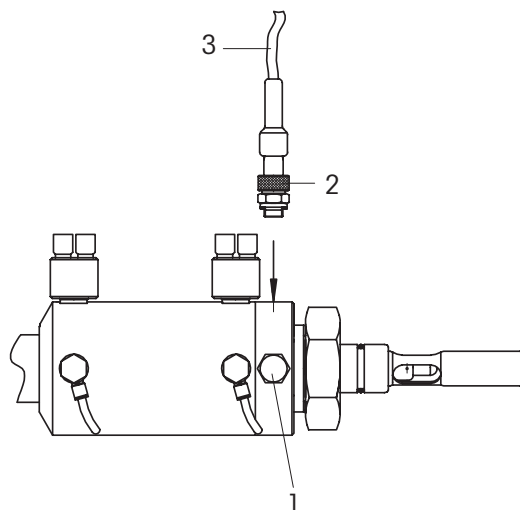

1. Remove blind plug (G 1/8").
2. Screw in temperature sensor (Pt100/Pt1000) together with sealing ring then tighten using a small spanner.
3. Connect the temperature sensor to the corresponding input terminal of the amplifier.

## 4.2.8 Fitting the electrode/sensor

**Retractable housings InTrac 777 e/779e as well as InTrac 797 e/799e**

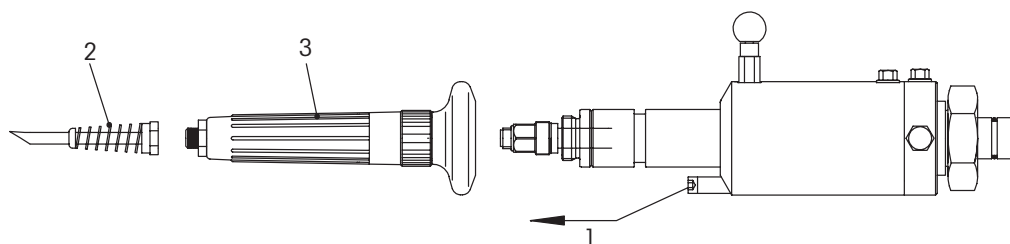

1. Set the housing to the "Maintenance" position.
2. Unscrew the positive position rod "1".
3. Unscrew the cable antikink "2".
4. Unscrew the protective sleeve "3".
5. Check that the correct type of electrode/sensor has been selected (see Chapter 10 "Appendices" on page 68).



6. Check the electrode/sensor for damage (e.g. breakage of electrode).

**Caution!** A damaged electrode/sensor must never be installed.

7. Check washers and O-rings on electrodes/sensors and replace if necessary.

8. Remove watering cap from the tip of the electrode/sensor and rinse electrode/sensor with water.

9. Carefully insert electrode/sensor into the immersion tube and screw in by hand as far as it will go.



**Danger!** Under no circumstances whatsoever may tools be used.

10. Remove the cover cap of the electrode/sensor screw cap connection.

11. Run the connection cable through the antikink protection "2" (see Chapter 4.2.8 "Fitting the electrode/sensor" on page 46) and protective sleeve "3", and connect the plug to the electrode/sensor.

12. Mount protective sleeve "3" (see Chapter 4.2.8 "Fitting the electrode/sensor" on page 46, "Fitting the electrode/sensor") and tighten by hand. Finally, also hand-tighten the cable antikink protection "2".

13. Screw in the positive position rod "1" again.



**Attention:** When installing a VP cable, the cable end (see drawing, Pos.1) should first be pulled through the protective sleeve (see drawing, Pos 2), before it is connected to the transmitter.

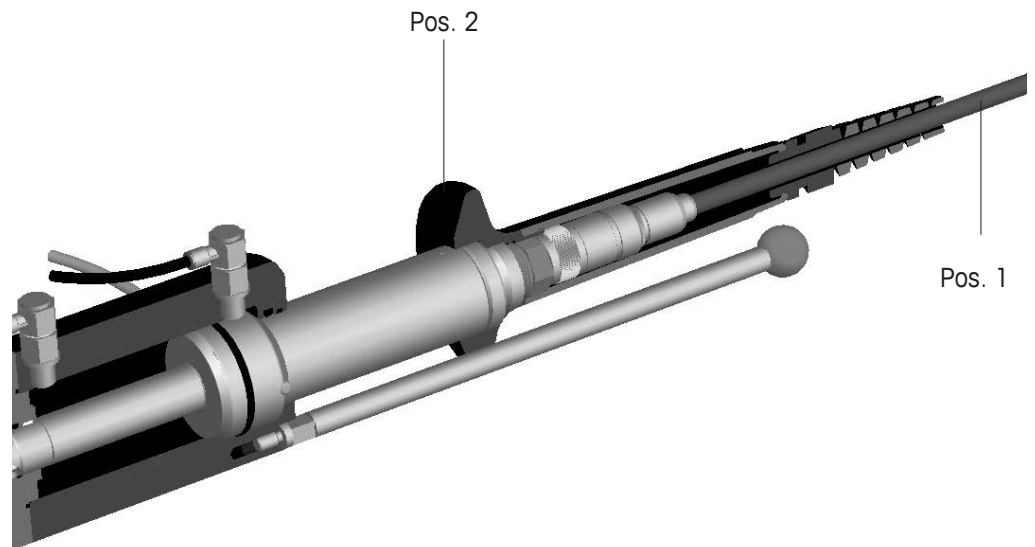

### Retractable housing InTrac 776 e

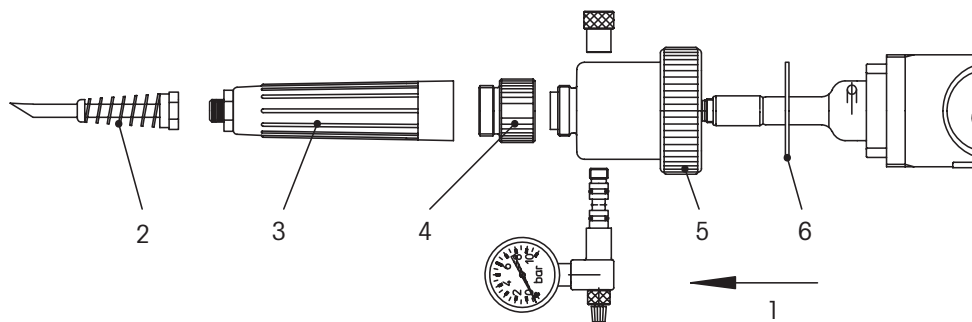

**Caution!** Tightening of the ring nut "5" and the plastic adapter "4" (see diagram above; "Fitting the electrode/sensor") in the wrong order, can lead to breakage of the pH/redox electrode. It is therefore essential to follow the procedure described below:

1. Set the housing to the "Maintenance" position.
2. Unscrew the cable antikink protection "2".
3. Unscrew the protective sleeve "3", the plastic adapter "4", and finally "5".
4. Check that the correct type of pH/redox electrode has been selected (see Chapter 10 "Appendices" on page 68).
5. Check the electrode for damage.



**Caution!** A damaged electrode must never be installed.

6. Remove the watering cap from the tip of the electrode, the stopper from the filling port, and the rubber band. Then rinse the electrode with water.



**Danger!** After removing the stopper, do not tilt the electrode, as reference electrolyte may spill out through the open filling port.

7. Check the level of the reference electrolyte in the electrode and top up if necessary (see Instruction Sheet of the relative electrode).
8. Carefully insert the electrode into the immersion tube until it comes up against the PTFE saddle.



**Attention:** If installing in an inclined position, ensure that the marking "Position electrode this side up" points upwards. In this position no reference electrolyte can flow out through the filling port (assuming that the fill level is correct).



9. Check gasket "6" at upper part of housing for damage and replace if necessary. Mount upper part of housing and tighten ring nut "5" by hand.



**Caution!** Ring nut "5" of upper part may be tightened **only with plastic adapter "4" removed**.

10. Check condition of seal of plastic adapter "4" and replace if necessary. Mount plastic adapter "4" and tighten by hand.
11. Remove the cover cap of the plug connection of the electrode.
12. Run the connection cable through the antikink protection "2" and protective sleeve "3", and connect the plug to the electrode.
13. Mount protective sleeve "3" and tighten by hand.  
Finally, also hand-tighten the cable antikink protection "2".
14. Set the compensation pressure in the housing. The compensation pressure can be set with a bicycle pump via the valve assembly at the pressure gauge, or established by attaching a permanent (dry, oil-free and filtered) compressed air supply (using the pressure connection set included in the standard equipment supply).



-  **Attention:** To ensure electrolyte flow from the reference electrode to the sample medium the air pressure in the upper part of the housing must be at least 0.5 bars and maximum 2 bars above that of the sample medium (take the hydrostatic pressure of the sample medium into account).
-  **Attention:** If there is no (positive) pressure differential to the sample medium, no reliable measurements can be taken.

## 4.3 Startup procedures for housings

### 4.3.1 Startup of manually operated housings

Before startup, all fitting and installation work (see Chapter 4.2 "Fitting and installation work" on page 40) must have been completed!

Each time before startup, check the measuring system. Inspect the electrode/sensor assembly and examine for leaks from housing and apparatus (see also Chapter 7 "Trouble shooting" on page 61). Do not commence operation until the measuring system has been checked and any necessary corrective action taken.

Before startup of an Ex-proof housing in a hazardous area, it is to be clarified beyond doubt that it is permitted to use the housing in question in conjunction with the other associated plant resources.

#### Proceed as follows for startup:

1. Pull the red knob of the locking pin, in order to release the immersion tube.

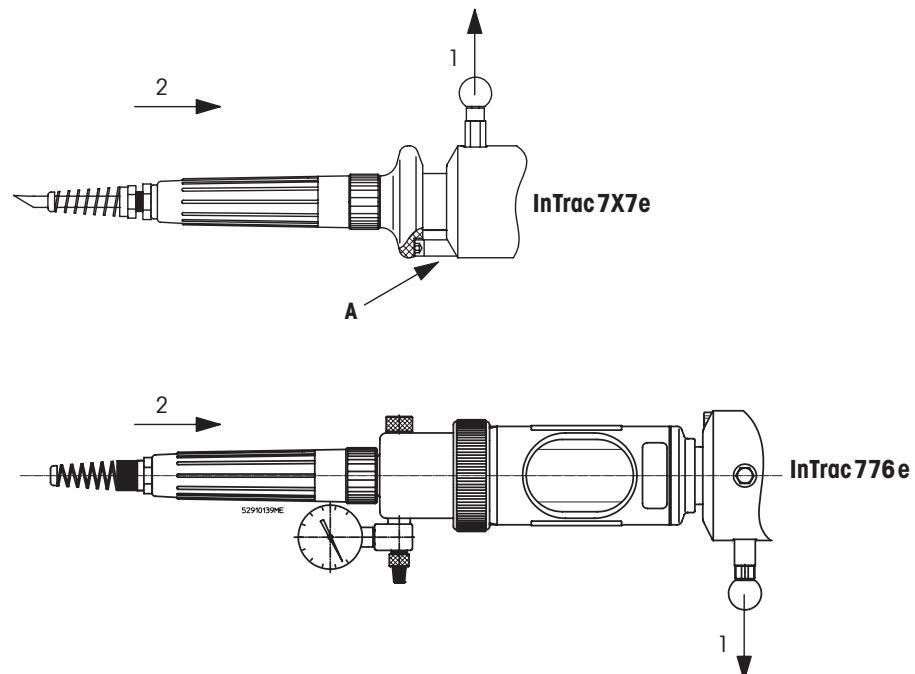

2. Carefully push the immersion tube into the "Measuring" position. The immersion tube must engage the lower limit stop. For the housing types InTrac 7X7e and InTrac 7X9e, the immersion tube must be turned clockwise until the recess in the handle (protective sleeve) aligns with the positive position rod "A". The immersion tube can now be fully inserted into the "Measuring" position and there is an audible click when the locking pin engages. Position "A" does not apply in the case of the housing InTrac 776e.

### 4.3.2 Startup of pneumatically operated housings

Before startup, all fitting and installation work (see Chapter 4.2 "Fitting and installation work" on page 40) must have been completed!

Each time before startup, check the measuring system, inspect the electrode/sensor assembly and examine for leaks from housing and apparatus (see also Chapter 7 "Trouble shooting" on page 61). Do not commence operation until the measuring system has been checked and any necessary corrective action taken.

Before startup of an Ex-proof housing in a hazardous area, it must be established beyond doubt that it is permitted to use the housing in question in conjunction with the other associated plant resources.

#### Proceed as follows for startup:

1. Open the air supply for the control system. Check:
  - the insertion and retraction motion of the immersion tube, as well as the status of the indicators for the respective end positions.
  - the control air system for tightness. Immediately seal any leaking connections.
2. Move the immersion tube into the "Maintenance" position and open flushing water supply (2 bar). Check flushing water system for tightness. Immediately seal any leaking connections.
3. If the system is equipped for calibration of the measuring system, move the housing into the "Maintenance" position and perform a calibration (see Chapter 5.4 "Calibrating the measuring system" on page 56). Check:
  - for correct calibration procedure.
  - the buffer solution systems for tightness. Immediately seal any leaking connections.

On successful completion of all function checks, the equipment in which the housing is installed can be started up.



**Caution!** Following startup of the equipment, particular care must be taken in any manipulations at the retractable housing. Therefore it is essential to pay close attention to the information in Chapter 5.1 "Important information for everyday operation" on page 55.

## 4.4 Shutdown procedure for manually and pneumatically operated housings



**Caution!** In the case of manually operated housings, locking pin "B" (see drawing) must snap into the hole "C" (see drawing) in the piston. This is achieved by turning the immersion tube clockwise after withdrawal.

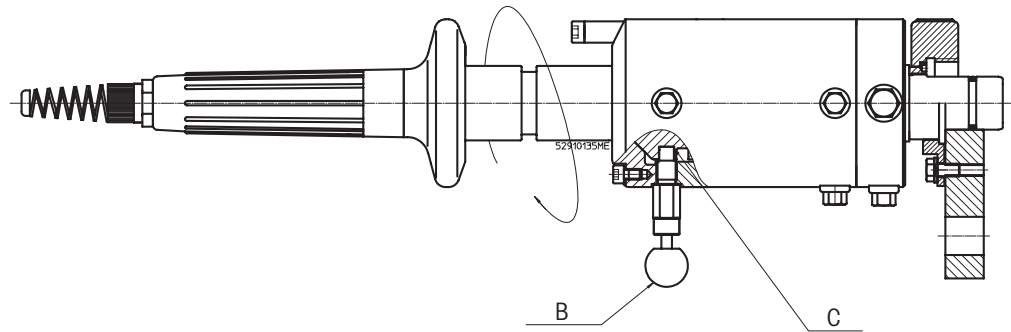

1. Move housing to the "Maintenance" position.
2. Open flushing water supply, flush electrode/sensor and close flushing water supply again.
3. **Isolate the pipe/tank/vessel etc, from the housing** (depressurize, empty, rinse, purge and vent, etc.).
4. Close control air feed to the housing.

## 4.5 Dismantling work

### 4.5.1 Removing the electrode/sensor



**Caution!** Removal and installation of the electrodes/sensors may only be performed in the "Maintenance" position of the housing.

#### InTrac 777 e/779 e and InTrac 797 e/799 e retractable housings

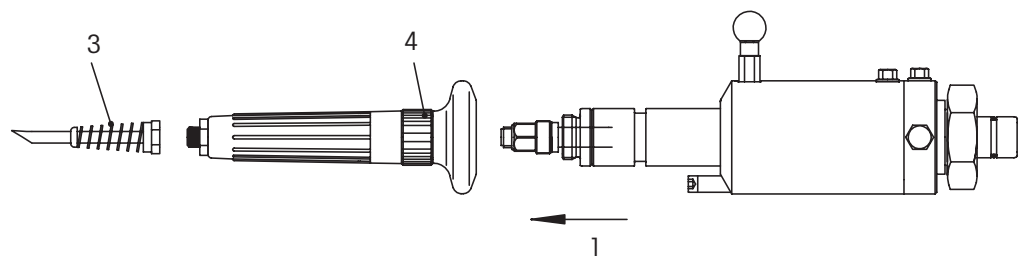



1. Move the housing into the "Maintenance" position.  
**Attention:** Ensure that the locking pin "B" snaps into the hole in the piston (see drawing Chapter 4.4 "Shutdown procedure for manually and pneumatically operated housings" on page 51.).
2. Open flushing water supply, flush electrode/sensor and close flushing water supply again.
3. If in place, screw out the (long) positive position rod.
4. Unscrew cable antikink "3".
5. Unscrew protective sleeve "4".
6. Disconnect the signal cable from the electrode/sensor.
7. Unscrew electrode/sensor and carefully remove from immersion tube.

### InTrac 776 e retractable housing



**Caution!** If the plastic adapter "4" and the ring nut "5" are loosened in the wrong order, this can lead to breakage of the pH/redox electrode. It therefore essential to following the procedure described below.

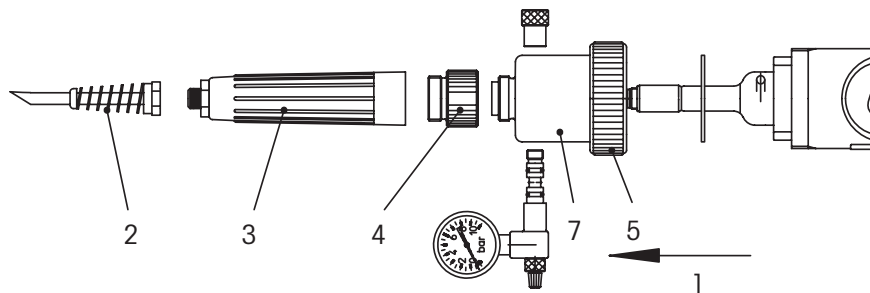



1. Move the housing into the "Maintenance" position.
2. Open flushing water supply, flush electrode/sensor and close flushing water supply again.
3. Depressurize the upper part of the housing by slightly loosening the valve assembly at the pressure gauge or by interrupting the compressed air supply. Retighten the valve assembly.
4. Remove cable antikink "2" and protective sleeve "3".
5. Disconnect the signal cable from the electrode.
6. Remove plastic adapter "4".
7. Undo ring nut "5" and remove upper part "7".
8. Carefully withdraw the electrode from the immersion tube.



**Attention:** Specific information on the electrode (calibration/alignment with the measuring system, storage, etc.) is to be found in the relative documentation for the electrode or measuring system.

## 4.5.2 Removing the retractable housing

1. Shut down the housing (see Chapter 4.4 "Shutdown procedure for manually and pneumatically operated housings" on page 51).
2. Remove the electrode/sensor (see Chapter 4.5.1 "Removing the electrode/sensor" on page 51).
3. Dismantle flushing water and control air lines.
  -  **Caution!** Close the connection in order to prevent ingress of dirt.
4. Undo ring nut or flange connection and carefully remove housing.
  -  **Caution!** Never place or support the housing on the front ends of the centering spigot or immersion tube (risk of damage).

## 4.6 Using cables with BNC plugs or preamplifiers (ISFET electrodes)

If your pH cable has a BNC connector or you wish to employ a pH-electrode of the ISFET type with integrated preamplifier, the standard antikink on the protective sleeve cannot be used since the bore is too narrow. In such case, simply unscrew the antikink "A", replace with a rubber grommet and insert this into the protective sleeve "B".

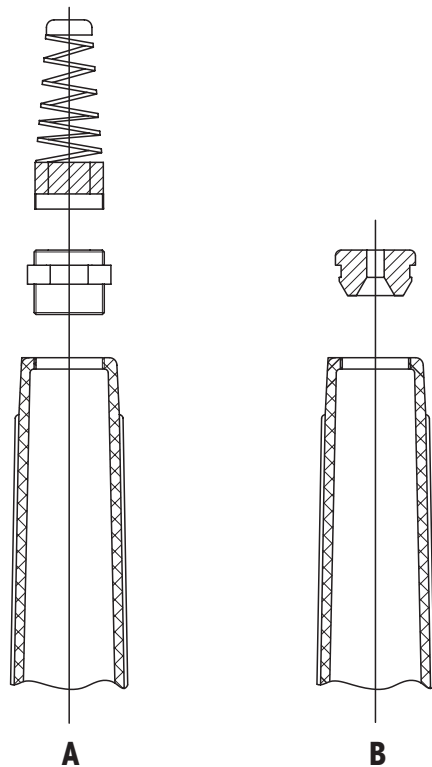

## 4.7 Use of retractable housings in conjunction with EasyClean

The retractable housing can be employed in conjunction with METTLER TOLEDO's cleaning and calibration system, EasyClean. This enables full automation of the measuring system. Current regulations together with the connection instructions given in the relative Instruction Manual, as well as directives governing pneumatic and water connections are to be fully observed at all times.



**Caution!** In the case of installations intended for operation in hazardous areas, only EasyClean 400X system may be used in conjunction with an Ex-proof certified housing (inductive position indicator Ex-proof). For installations in non-hazardous areas, housings with non-Ex inductive position indicators may be employed.

### System overview EasyClean 400

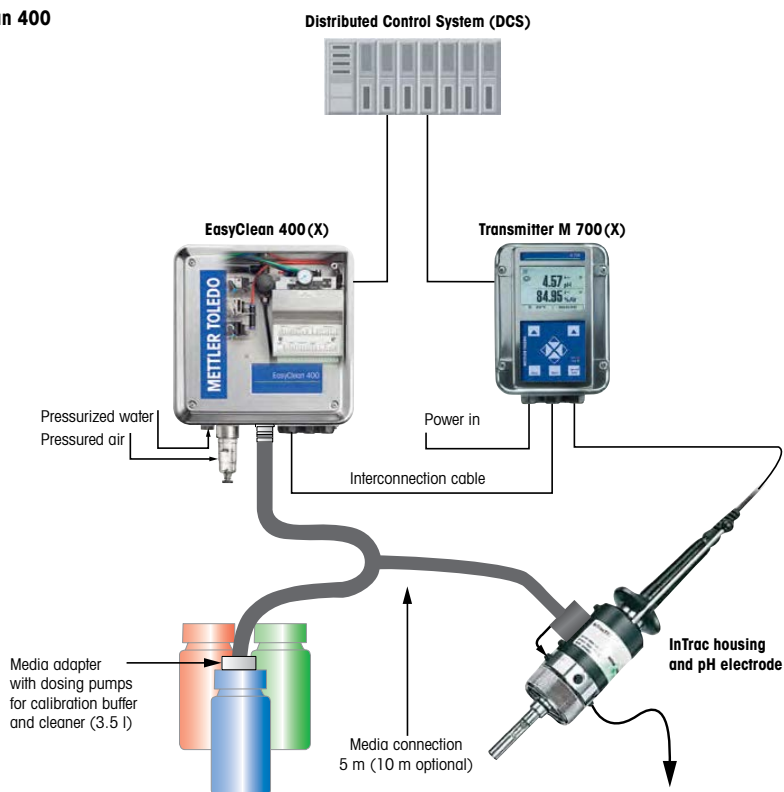

## 5 Operation

---

### 5.1 Important information for everyday operation



**Caution!** No attempt may be made to move the immersion tube into the “Measuring” position without an electrode/sensor installed, otherwise sample medium can flow out via the open immersion tube.

During operation,

- **never** loosen the lines of the pneumatic system or of the flushing and buffer solutions.
- **never** remove fastening components (screw/bolts of flange, ring nut, etc.).

If any malfunctions occur during operation, the equipment in which the housing is installed must first be made safe before any corrective measures are taken.

For all work on the equipment during everyday operation, wear the stipulated protective clothing (protective goggles, gloves, breathing apparatus, etc).

### 5.2 Inspection work in everyday operation

The following inspection work should be performed in everyday operation:

- Check all systems such as air, flushing water and buffer solutions for leaks.
- Check fastenings (ring nut, flange, NPT-thread) of the housing at the vessel for firm seating and leaks.
- Check the condition of the electrode/sensor. A faulty or damaged electrode/sensor must be replaced immediately.

Additional check to the housings **with pressure compensation** (InTrac 776 e):

- Check functioning of pressure gauge.
- Check air pressure in upper part (pressure gauge). The air pressure must be at least 0.5 bars and maximum 2 bars above that of the sample medium (take hydrostatic pressure of the sample medium into account) to ensure the flow of electrolyte from the reference electrode to the sample medium.



**Attention:** The desired overpressure is set with a bicycle pump via the valve assembly at the pressure gauge or established by means of a compressed air supply.

- Check level of the reference electrolyte. The level of the reference electrolyte steadily sinks due to outflow through the diaphragm. If the liquid level has sunk to a level below the mouth of the bulb (reservoir) of the pH/redox electrode, then the reference electrolyte must be topped up (see Chapter 6 “Maintenance” on page 57).

## 5.3 Cleaning the electrode/sensor

The electrode/sensor must be cleaned before removal, before calibration of the measurement system or at regular intervals during operation (depending on the process medium). Proceed as follows:

1. Move the housing into the "Maintenance" position.
2. Open flushing water supply and flush the electrode/sensor.
3. Close flushing water supply again.

## 5.4 Calibrating the measuring system

The frequency of calibration of the measurement system depends on the electrode/sensor type and the sample medium. To calibrate the measurement system, proceed as follows:

1. Move housing into the "Maintenance" position.
2. Open flushing water supply, flush electrode/sensor and then close flushing water supply again.
3. Remove electrode/sensor (procedure, see Chapter 4.5.1 "Removing the electrode/sensor" on page 51).



**Attention:** This is only necessary if your installation does not allow calibration of the measurement system with the electrode/sensor installed.

4. Perform calibration in accordance with the operating instructions for the respective electrode/sensor and transmitter.

Re-install electrode/sensor (procedure, see Chapter 4.2.5 "Fitting of 3/2-way valve for position indicator" on page 45).



**Attention:** This is only necessary if your installation does not allow calibration of the measurement system with the electrode/sensor installed.

5. Open flushing water supply, flush the electrode/sensor and then close flushing water supply again.
6. Move the housing into the "Measuring" position.



## 6 Maintenance

### 6.1 Important information on maintenance

**Establish a service plan adapted to your process.**

**Consult your local METTLER TOLEDO representative for details.**



**Danger!** The information and instructions given in Chapter 1 "Introduction" on page 9 and Chapter 2 "Important notes for housing uses in Ex-Classified area" on page 21 must be fully adhered to.



**Caution!** Maintenance and service work on the housings may only be carried out by appropriately trained personnel.

Only original spare parts from METTLER TOLEDO may be used, otherwise all guarantees become automatically invalid. Only the maintenance and repair work described in the following Chapters may be performed on the retractable housings.



**Caution!** It is possible that the process medium could harm the environment and your health (toxic, caustic, corrosive, etc.). Therefore, ensure that the equipment is in a non-hazardous condition before you start with any maintenance work.



**Danger!** Before startup, the housing must be checked to ensure that:

- the right types of O-ring have been selected and that they are undamaged and correctly positioned (flushing chamber, immersion tube).



- **Attention!** Only original spare parts from METTLER TOLEDO may be used, otherwise all guarantees become automatically invalid.

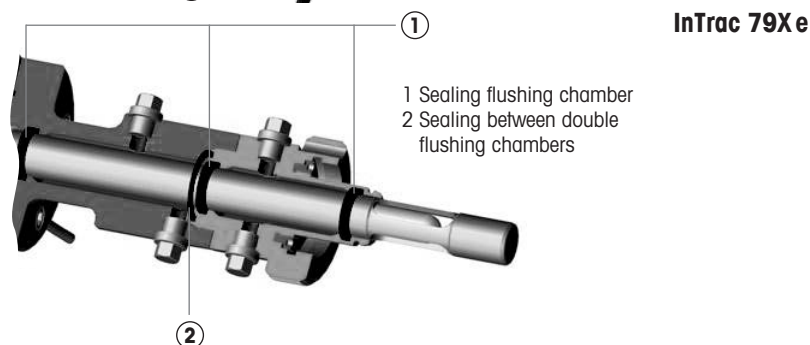
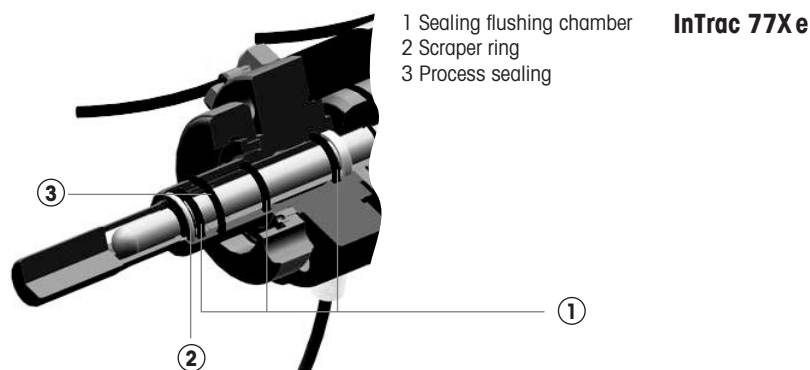

## 6.2 Topping up reference electrolyte

The work described below applies only for pH/redox electrodes with liquid reference electrolyte. In order to top up the reference electrolyte, proceed as follows:

1. Remove electrode (see Chapter 4.5.1 "Removing the electrode/sensor" on page 51).



**Attention:** The reference electrolyte may not be topped up with the electrode installed.

2. Top up reference electrolyte (Electrolyte No. see marking "Refill" on the electrode).



**Caution!** Take care not to exceed the maximum filling level.

3. Re-install the electrode (see Chapter 4.2.8 "Fitting the electrode/sensor" on page 46).

**Do not allow any spillage of reference electrolyte to remain in the housing.**

**Wash out and dry the housing.**

## 6.3 Conversion of InTrac 777 e to InTrac 776 e

(For pH and redox electrodes only)

To carry out conversion, proceed as follows:

1. Shut down the housing (see Chapter 4.4 "Shutdown procedure for manually and pneumatically operated housings" on page 51).
2. Remove the housing from its working location (see Chapter 4.5.2 "Removing the retractable housing" on page 53).
3. Unscrew the protective sleeve from the housing and disconnect the electrode cable.
4. Remove the electrode.
5. Screw the adapter (order no. 52 403 305) for liquid-filled electrodes onto the top end of the immersion housing. Secure with a set screw.
6. Screw on the protective sleeve again together with the cable antikink protection.
7. Insert an electrode of the liquid-electrolyte type (see Chapter 4.2.8 "Fitting the electrode/sensor" on page 46).
8. The housing is now ready for installation at its working location.

## 6.4 Replacing seals in contact with the process medium

**All seals that come into contact with process medium should always be replaced at least every 6 months.** With **aggressive media**, the seals may need to be changed at correspondingly **shorter intervals**. Medium-wetted seals must be examined at least monthly, as well as during normal maintenance procedures, to check for dirt or damage. Frequent insertion and retraction motion of the immersion tube can also have an influence on the necessary maintenance intervals.



**Attention:** Seals are wearing parts which must be regularly examined by the operator of the housing, and replaced if necessary (dependent upon application).

### Replacement of medium-wetted seals

ALL medium-wetted seals should under all circumstances be replaced at least every 6 months.

### Check on medium-wetted seals

ALL medium-wetted seals should under all circumstances be examined and checked every 3 months.

**In the case of aggressive or abrasive media, the seals may need to be checked at shorter intervals.**



**Attention:** Recommendations by METTLER TOLEDO concerning maintenance intervals are based solely on experience gained in standard applications and in no way binding or an admission of any guarantee liability whatsoever on the part of the manufacturer/supplier. Depending upon the degree of aggressiveness of the process medium, the necessary maintenance intervals to support smooth operation of the equipment may be correspondingly shorter.



**Attention:** Details of replacements and examination of the seals are to be documented in the maintenance log.

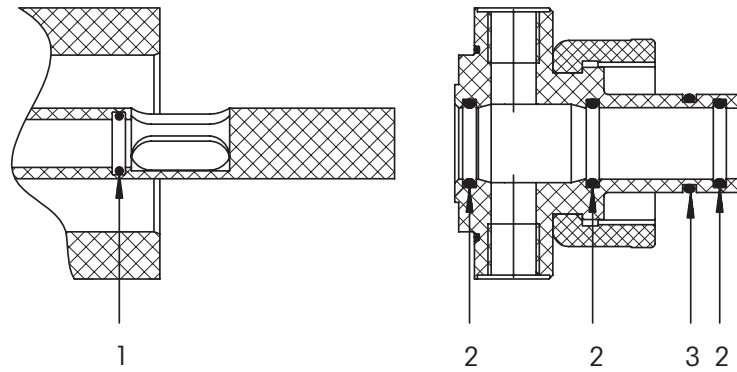

### Flushing chamber (O-rings "2"):

EPDM  $\varnothing 17.86 \times 2.62$ , Viton<sup>®</sup>:  $\varnothing 17.86 \times 2.62$ , Kalrez<sup>®</sup>:  $\varnothing 17.86 \times 2.62$

### Immersion tube (O-ring "1"):

EPDM  $\varnothing 10.77 \times 2.62$ , Viton<sup>®</sup>:  $\varnothing 10.77 \times 2.62$ , Kalrez<sup>®</sup>:  $\varnothing 10.78 \times 2.62$

### Centering spigot (O-ring "3"):

EPDM  $\varnothing 20.29 \times 2.62$ , Viton<sup>®</sup>:  $\varnothing 20.24 \times 2.62$ , Kalrez<sup>®</sup>:  $\varnothing 20.29 \times 2.62$



**Attention: All O-rings are made of FDA approved materials.**



### Caution!

- Retractable housings may only be stripped down for maintenance and repair work after having been completely dismantled from the equipment in which they were installed for operation.
- Only perform the dismantling work described and instructed in this Chapter and replace only the seals listed above. Check that the correct types of seals have been selected, examine for any signs of damage and for correct seating.
- Ensure that the seals are of the correct material quality (see Chapter 8 "Product specifications" on page 62).

To replace the seals, proceed as follows:

1. Shut down the housing (see Chapter 4.4 "Shutdown procedure for manually and pneumatically operated housings" on page 51).
2. Remove electrode/sensor from the housing (see Chapter 4.5.1 "Removing the electrode/sensor" on page 51) and store as described in the electrode/sensor Operating Instructions.
3. Remove the housing from the equipment (reactor, vessel, pipe) in which it is installed (see Chapter 4.5.2 "Removing the retractable housing" on page 53) and place it on a clean working surface.



**Caution!** Never place or support the housing on the front ends of the centering spigot or immersion tube (risk of damage).

4. Unscrew the four screws of the lock chamber fastening and carefully remove the complete lock chamber from the guide tube.
5. Remove the indicated seals with a fine hook. Ensure that the contact surfaces of the seals are thereby not scratched.



6. Lightly grease new O-rings (set of seals) **with lab grease!**

**Caution! No grease may be applied to the O-Ring "1" in the immersion tube**, as there is a danger that grease could contact and adhere to the electrode/sensor tip (diaphragm/glass membrane) when reinstalling the electrode/sensor, and have adverse effects on its function.

7. Carefully insert O-rings **"1"** (immersion tube) and **"3"** (centering spigot) as well as O-rings **"2"** (lock chamber) using the assembly mandrel (order no, 90 770 1790).
8. Check the O-ring on the centering spigot of the lock chamber and replace if necessary. Lightly smear **O-ring with lab grease.**
9. Carefully push the lock chamber over the immersion tube. Align the positioning pin of the lock chamber with the hole in the guide tube and guides of the immersion tube piston with the corresponding bores in the lock chamber.
10. Mount lock chamber on the guide tube and fasten tightly with the four screws. For further in stallation work (e.g. attachment to a vessel, connection of pneumatic and flushing water systems, etc.) see Chapter 4.2 "Fitting and installation work" on page 40.

## 7 Trouble shooting

In this Chapter you will find an overview of possible malfunctions which could appear during operation of the retractable housings, their cause, as well as a guide to appropriate remedial measures.



**Danger!** It is essential to comply with the safety instructions given in Chapter 1 "Introduction" on page 9 and Chapter 2 "Important notes for housing uses in Ex-Classified area" on page 21.

Malfunction	Cause	Remedial action
<b>Immersion tube cannot be inserted</b>	There is no electrode/sensor installed in the housing	Install an electrode/sensor
<b>Immersion tube remains stuck between the end positions "Maintenance" and "Measuring"</b>	No or insufficient control air pressure	Check control air system /adjust pressure
	Leak in control air system	Check/make leakproof control air system
	Deposits of sample medium lead to seizing of immersion tube	Remove housing and clean (see Chapter 6 "Maintenance" on page 57)
<b>Sample medium discharges via flushing lines</b>	Seals of flushing chamber are defective	Remove housing and replace seals (see Chapter 6 "Maintenance" on page 57)
<b>Sample medium escapes between ring nut and weld-in socket</b>	O-ring at centering spigot of retractable housing defective	Replace O-ring
<b>Sample medium escapes at the flange connection/fastenings</b>	Flange connection unevenly positioned or not fastened tightly enough	Check positioning of flange connection and/or tighten the fastenings
	Flange gasket defective	Check gasket and replace if necessary
<b>Sample medium escapes through the NPT thread</b>	Thread insufficiently sealed	Seal using PTFE tape
<b>InTrac 776 e: No pressure in upper part (pressure compensation) or drops rapidly</b>	Compensation pressure not (correctly) set	Set compensation pressure with pump or check compressed air supply
	Leak in upper part	Check screw fittings and seals
	Broken electrode	Replace electrode
<b>Incorrect measurement values / fluctuations in measurement data</b>	Defective electrode/sensor or transmitter	Check electrode/sensor and transmitter. Replace or repair as necessary
<b>End positions are not indicated</b>	Power failure	Check power supply
	Defect in inductive indicator. Air supply failure in pneumatic indicator	Check indicators, and replace or repair as necessary



**Danger!** Breakage of the protection caging can lead to mixing of process medium and cleaning medium.

## 8 Product specifications

### 8.1 Technical data

#### 8.1.1 Technical specifications InTrac 776 e



**Attention:** The technical specifications for the installed sensors must also be taken into account.

##### Ambient conditions

Temperature 0...70 °C/32...158 °F  
(with steel cylinder: -10...70 °C/14...158 °F)

##### Process conditions

Functional pressure range	manual:	0...5 bar	0...73 psig
	pneumatic:	0...8 bar	0...116 psig
Max. permissible pressure [PS]/[TS]* (linear decreasing for polymer housings)	<b>PP</b>	6 bar / 20 °C	87 psig / 68 °F
		0 bar / 80 °C	0 psig / 176 °F
	<b>PVDF</b>	6 bar / 20 °C	87 psig / 68 °F
		1 bar / 110 °C	15 psig / 230 °F
	<b>PEEK</b>	6 bar / 20 °C	87 psig / 68 °F
		1 bar / 110 °C	15 psig / 230 °F
	<b>1.4404/316L</b>	6 bar / 130 °C	87 psig / 266 °F
	<b>2.4602/Alloy</b>		
	<b>C22, Ti</b>	6 bar / 130 °C	87 psig / 266 °F

##### Operating mode

manual or pneumatic

##### Immersion depth

70 mm, 100 mm, 200 mm

##### Medium-wetted parts

DIN 1.4404/AISI 316L, DIN 2.4602/Alloy C22,  
titanium, PP, PVDF, PEEK

##### Medium-wetted seals (O-rings)

Viton®-FDA, EPDM-FDA,  
Kalrez®-FDA and USP Class VI

##### Non-wetted parts

body: polypropylene (PP) conductive, or  
stainless steel DIN 1.4404/AISI 316L  
handle/protective sleeve complete:  
polypropylene (PP) conductive

##### Weight

approx. 4.5 kg

##### Outer dimensions\*\*

Short version (70/100 mm)	length: approx. 545 mm in "Measuring" position
	length: approx. 710 mm for removal of electrode
Long version (200 mm)	length: approx. 645 mm in "Measuring" position
	length: approx. 1110 mm for removal of electrode

**Control air for pneumatic operation** 4...8 bars/58...116 psig

\* Pressure details according to PED 2014/68/EU (OJEU, 2014, L189, P164).

\*\* See dimension drawings in Chapter 10 "Appendices" on page 68.

<b>Air quality to ISO 8573-1</b>	moisture, Class 4 (pressure dewpoint +3 °C [37.4 °F]) solids, Class 5 (filter 40 µm) max. oil content, Class 2 (0.1 mg/m <sup>3</sup> ) air connections to suit air hoses 6/4 mm
<b>Flushing connections</b> (water, steam or cleaning solutions)	2...6 bar/29...87 psig 1x connection "IN": thread G 1/8" 1x connection "OUT": thread G 1/4" 1x connection "TEMP": thread G 1/8"
<b>Position monitoring</b>	pneumatic indicators (3/2-way valve); G 1/8" inductive indicators, non-Ex, M12x1 inductive indicators, Ex-proof, M12x1
<b>Pressure details</b>	"pressure" is referenced to atmospheric pressure, i.e. overpressure; accordingly, pressures in the vacuum range are expressed as negative (pressure) values.
<b>Protection against explosion</b> (Valid for all housings with medium-wetted parts made of metal)	According to ATEX guidelines (94/9/EG): ⊕ II 1/2G c IIC TX Ga/Gb ⊕ II 1/2D c IIIC TX Da/Db SEV 13 ATEX 0161 X According to FM guidelines: IS CL I,II,III, Div 1, GR A,B,C,D,E,F,G Ta = 60 °C FM control drawing: 53800002; Entity Original project ID 3021227; FM Certificate number: FM16US0034X FM18CA0021X
<b>Certificates/approvals</b>	Depending on housing model, following certificates/ approvals are included: – CE Declaration of Conformity – Pressure Equipment directive, – Certificate of Conformity according to EN10204 2.1, material certificate according to 3.1B – ATEX directive – FM Class 3600, 3610, 3810 – MaxCert™

## 8.1.2 Technical specifications for InTrac 77Xe/InTrac 79Xe



**Attention:** The technical specifications for the installed sensors must also be taken into account.

### Ambient conditions

Temperature 0...70 °C/32...158 °F  
(with steel cylinder: -10...70 °C/14...158 °F)

### Process conditions

Functional pressure range	manual:	0...5 bar	0...73 psig
	pneumatic:	0...8 bar	0...116 psig
Max. permissible pressure [PS]/[TS]* (linear decreasing for polymer housings)	<b>PP</b>	6 bar / 20 °C	87 psig / 68 °F
		0 bar / 80 °C	0 psig / 176 °F
	<b>PVDF</b>	6 bar / 20 °C	87 psig / 68 °F
		1 bar / 110 °C	15 psig / 230 °F
	<b>PEEK</b>	6 bar / 20 °C	87 psig / 68 °F
		1 bar / 110 °C	15 psig / 230 °F
	<b>1.4404/316L</b>	16 bar / 140 °C	232 psig / 284 °F
	<b>2.4602/Alloy</b>		
	<b>C22, Ti</b>	16 bar / 140 °C	232 psig / 284 °F

### Operating mode

manual or pneumatic

### Immersion depth

InTrac77Xe: 70 mm, 100 mm, 200 mm  
InTrac 79Xe: 100 mm

### Medium-wetted parts

InTrac 77Xe: DIN 1.4404/AISI 316L, DIN 2.4602/-  
Alloy C22, titanium, PP, PVDF, PEEK  
InTrac 79Xe: DIN 1.4404/AISI 316L

### Medium-wetted seals (O-rings)

Viton®-FDA, EPDM-FDA,  
Kalrez®-FDA and USP Class VI

### Non-wetted parts

body: polypropylene (PP) conductive, or  
stainless steel DIN 1.4404/AISI 316L  
handle/protective sleeve complete:  
polypropylene (PP) conductive

### Weight

approx. 4.5 kg

### Outer dimensions\*\*

Short version 77Xe (70/100 mm)	length: approx. 360 mm in "Measuring" position length: approx. 515 mm for removal of electrode
Long version 77Xe (200 mm)	length: approx. 460 mm in "Measuring" position length: approx. 915 mm for removal of electrode
Version 79Xe (70/100 mm)	length: approx. 460 mm in "Measuring" position length: approx. 715 mm for removal of electrode

**Control air for pneumatic operation** 4...8 bar/58...116 psig

\* Pressure details according to PED 2014/68/EU (OJEU, 2014, L189, P164).

\*\* See dimension drawings in Chapter 10 "Appendices" on page 68.



<b>Air quality to ISO 8573-1</b>	moisture, Class 4 (pressure dewpoint +3 °C [37.4 °F]) solids, Class 5 (filter 40 µm) max. oil content, Class 2 (0.1 mg/m <sup>3</sup> ) air connections to suit air hoses 6/4 mm
<b>Flushing connections</b> InTrac77Xe (water, cleaning solutions)	2...6 bar/29...87 psig 1x connection "IN": thread G 1/8" 1x connection "OUT": thread G 1/4" 1x connection "TEMP": thread G 1/8"
InTrac79Xe (water, cleaning solutions, steam)	2...6 bar/29...87 psig 2x connections "IN": thread G 1/8" 2x connections "OUT": thread G 1/8" 1x connection "TEMP": thread G 1/8"
<b>Position monitoring</b>	pneumatic indicators (3/2-way valve); G 1/8" inductive indicators, non-Ex, M12x1 inductive indicators, Ex-proof, M12x1
<b>Pressure details</b>	"pressure" is referenced to atmospheric pressure, i.e. overpressure; accordingly, pressures in the vacuum range are expressed as negative (pressure) values.
<b>Protection against explosion</b> (Valid for all housings with medium-wetted parts made of metal)	According to ATEX guidelines (94/9/EG): ⊕ II 1/2G c IIC TX Ga/Gb ⊕ II 1/2D c IIIC TX Da/Db SEV 13 ATEX 0161 X According to FM guidelines: IS CL I,II,III, Div 1, GR A,B,C,D,E,F,G Ta = 60 °C FM control drawing: 53800002; Entity Original project ID 3021227; FM Certificate number: FM16US0034X FM18CA0021X
<b>Certificates/approvals</b>	Depending on housing model, following certificates/ approvals are included: – CE Declaration of Conformity – Pressure Equipment directive, – Certificate of Conformity according to EN10204 2.1, material certificate according to 3.1B – ATEX directive – FM Class 3600, 3610, 3810 – MaxCert™

## 8.2 Spare parts list

### Spare parts

Designation	Order no.
SP seal set Viton FDA 7XX	52 403 172
SP Seal set Kalrez-FDA	52 403 173
SP Seal set EPDM-FDA 7XX	52 403 174
Cable grommet set 5 mm/7 mm D21 7XX	52 403 463

### Accessoires

Designation	Order no.
Pt100-764/5 m	59 902 479
3/2 way reversion valve set (2 pcs.), pneumatic	52 401 324
Position indicator, non-Ex (2 pcs.), inductive	52 402 398
Set of position indicators, Ex-proof (2 pcs.), inductive	52 402 399
Connection set for flushing chamber SERTO	52 400 842
Connection set for flushing chamber SWAGELOK	52 400 843
Connection set for flushing chamber GYROLOK	52 400 844
Connection set for flushing chamber PVDF	52 400 768
Connection set for flushing chamber PVC	52 400 769
One-way Restrictor Valve GRL1/8 (1 pc*)	59 905 541

\* 2 pcs. are needed per housing

Replacement of all other parts of the housings may only be carried out by appropriately trained personnel. Please contact your local METTLER TOLEDO representative.

## 9 Decommissioning, storage, disposal



Please refer to Chapter 2 “Important notes for housing uses in Ex-Classified area” on page 21. Decommissioning may only be carried out by persons with appropriate training or by skilled technicians.

### 9.1 Decommissioning

Proceed as described in Chapter 4.5.2 “Removing the retractable housing” on page 53.

### 9.2 Storage

Store the InTrac7XX in a dry place. Before storage, the housing must properly cleaned and dry.

### 9.3 Disposal



It is recommended that the operator disposes of the device in accordance with local regulations. The operator must deliver the device either to a licensed private or public disposal company, or dispose of it himself in accordance with prevailing regulations. Waste is to be recycled or disposed of without causing any risk to human health, and without using procedures or methods that might harm the environment.

#### Sorting

Sorting into waste groups takes place when dismantling the device. The groups are listed in the current European Waste Catalogue. This catalog is valid for all wastes, whether intended for disposal or for recycling.

The packaging is made up of the following materials:

- cardboard
- foam plastic

**Depends on the housing configuration, in general the housing may be made of the following or a combination of the following materials:**

- Steel (i.e. DIN 1.4404/AISI 316L, and/or DIN 2.4602/AISI Alloy C22, and/or Titanium etc).
- Polypropylene (PP)
- Polyvinylidene Fluoride (PVDF)
- Polyether Ether Ketone (PEEK)

## 10 Appendices

### 10.1 Electrode/sensor selection

This is a brief overview of pH and redox electrodes suitable for use with specific media. For further information on the extensive range of electrodes and sensors available from METTLER TOLEDO, please contact your supplier.

#### Suitable electrodes/sensors

– <b>InTrac 776 e</b>		
Insertion length	H= 70/100 mm	H= 200 mm
Length of the electrodes	250 mm	450 mm
pH electrodes	InPro® 2000, 465-50	
Redox electrode	Pt4865-50	
– <b>InTrac 777 e</b>		
Insertion length	H= 70/100 mm	H= 200 mm
Length of the electrodes/sensors	220 mm or 225 mm	420 mm or 425 mm
pH	InPro 3200, InPro 4250, InPro 4800	
Redox	Pt4805	
Dissolved oxygen (DO)	InPro 6800/InPro 6900 (only 220 mm)	
CO <sub>2</sub>	InPro 5000 (only 225 mm)	
Leitfähigkeit	InPro 7001-VP (only 225 mm)	
– <b>InTrac 779 e</b>		
Insertion length	H= 70/100 mm	H= 200 mm
Length of the electrodes/sensors	207 mm	407 mm
Turbidity	InPro 8100, InPro 8200	
– <b>InTrac 797 e</b>		
Insertion length	H= 100 mm	
Length of the electrodes/sensors	320 mm or 325 mm	
pH	InPro 3030, InPro 3100	
Redox	Pt4805	
CO <sub>2</sub>	InPro 5000	
– <b>InTrac 799 e</b>		
Insertion length	H= 100 mm	
Length of the electrodes/sensors	320 mm or 325 mm	
Turbidity	InPro 8100, InPro 8200	

## 10.2 Dimensional drawing InTrac 776e

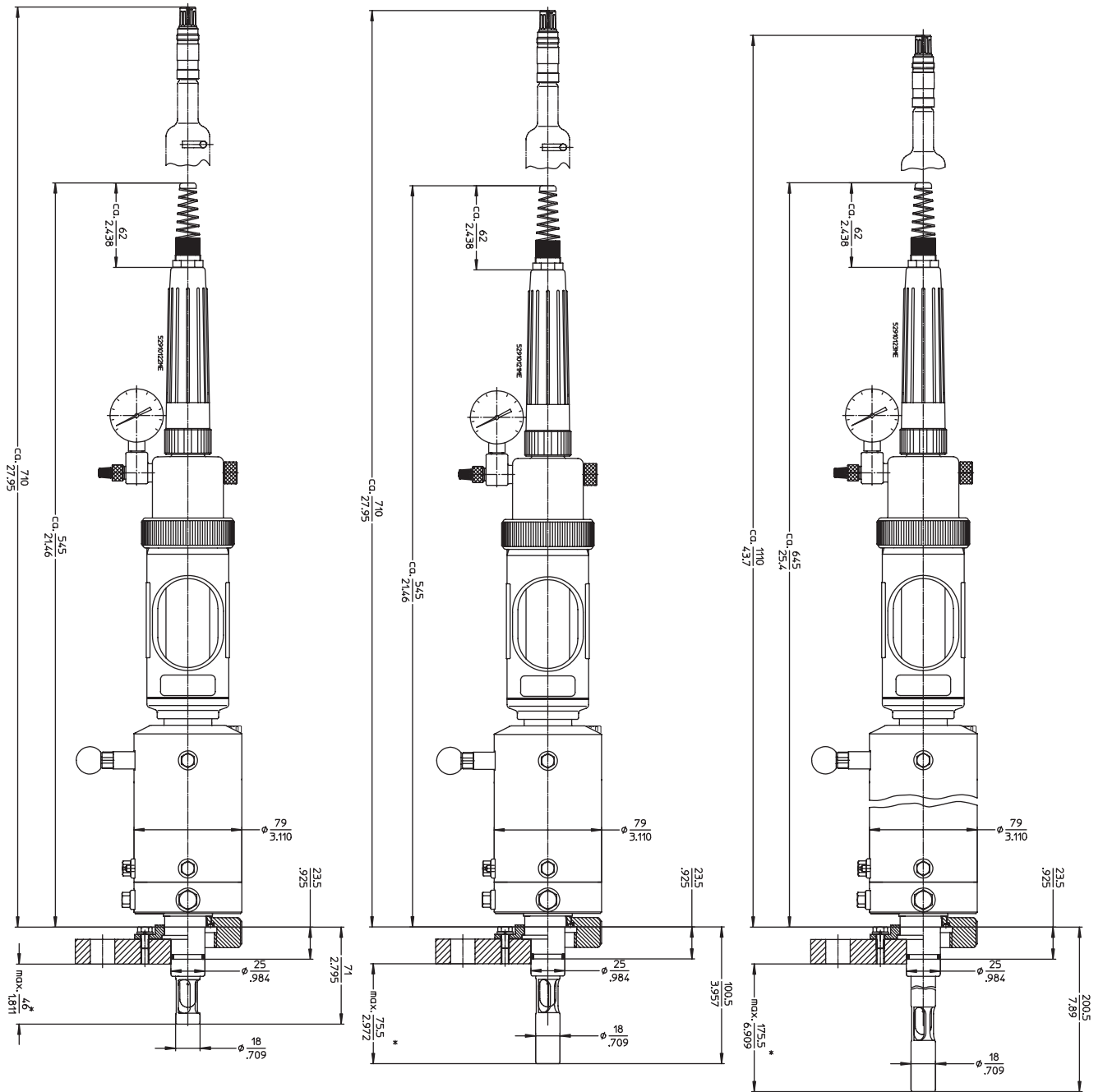

### 10.3 Dimensional drawing InTrac 777 e/InTrac 779 e

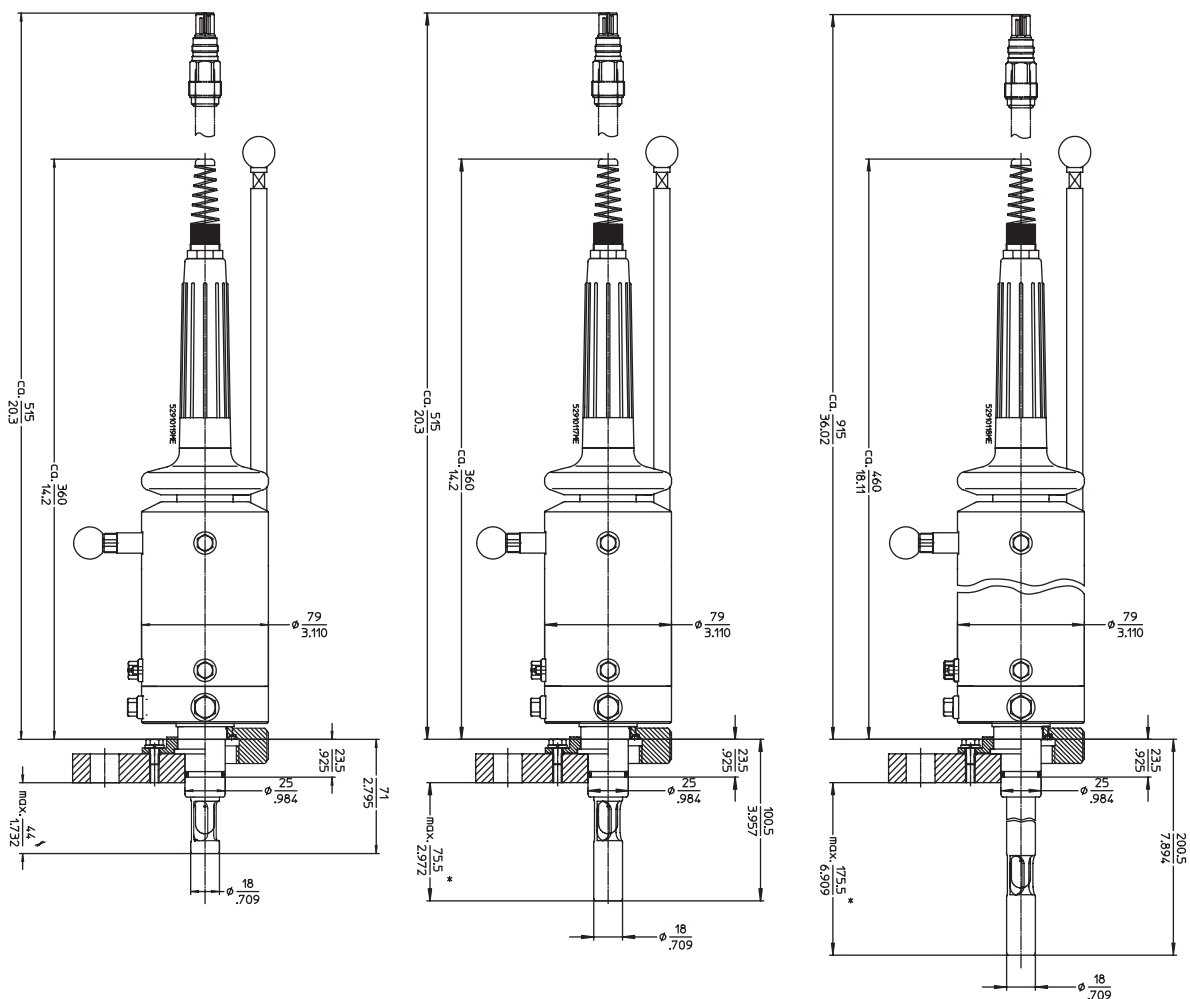

### 10.4 Dimensional drawing InTrac 797 e/InTrac 799 e

Manually operated InTrac 797 e with immersion depth 100 mm (left) and InTrac 799 e (right).

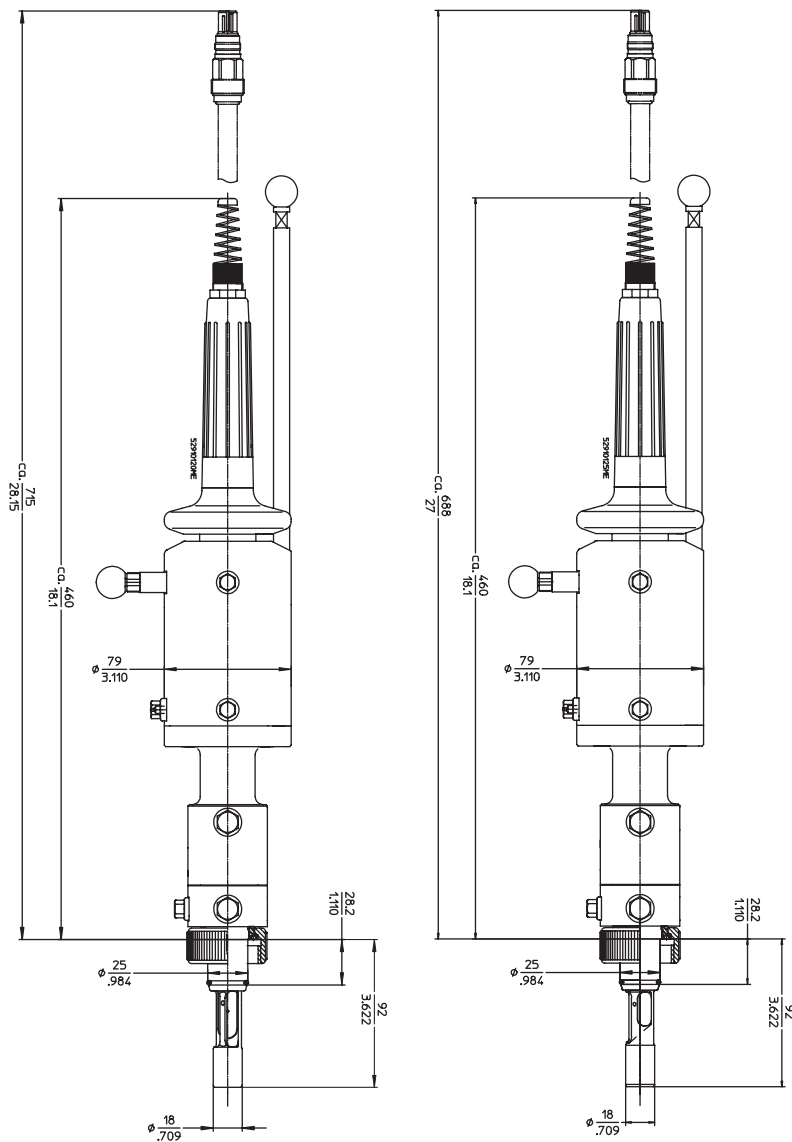

### 10.5 Product structure InTrac 776 e/InTrac 777 e/InTrac 779 e

Flushing chamber												
7	single flushing chamber											
Electrode/sensor type												
5	pH electrodes with dual-membrane, pNa reference system											
7	pH electrodes with gel-/polymer electrolyte and sensors with Pg 13.5 thread											
9	turbidity sensors											
Operation mode												
M	manual operation											
P	pneumatic operation											
R	pneumatic operation with pneumatic position indication											
I	pneumatic operation with inductive position indication non-Ex											
X	pneumatic operation with inductive position indication Ex											
Insertion length (H)												
0	7	0	H = 70 mm									
1	0	0	H = 100 mm									
2	9	5	H = 295 mm									
Material												
4	4	0	4	DIN 1.4404/AISI 316L								
C	2	2	-	DIN 2.4602/AISI Alloy C22								
T	I	-	-	Titanium								
P	P	-	-	Polypropylene								
P	V	D	F	Polyvinylidenfluoride								
P	E	E	K	Polyetheretherketone								
Process connections												
D	0	0	Ingold DN25 weld-in socket									
D	0	2	Flange DN32 PN16 (SS-version only)									
D	0	3	Flange DN40 PN16									
D	0	4	Flange DN50 PN16									
D	0	6	Flange DN80 PN16									
A	0	2	ANSI flange A150-1.5"									
A	0	3	ANSI flange A150-2"									
A	0	4	ANSI flange A150-3"									
N	0	1	NPT thread 1"									
N	0	2	NPT thread 1 1/4"									
N	0	3	NPT thread 1 1/2"									
T	0	1	Tri-Clamp 1.5"									
T	0	2	Tri-Clamp 2"									
V	0	1	Varivent DN50									
O-ring material												
V	I	Viton®-FDA										
E	P	EPDM-FDA										
K	a	Kalrez®-FDA and USP Class VI										
Body material												
A	PP conductive											
S	DIN 1.4404/AISI 316L											
Flushing connections												
0	without											
1	Serto ss											
2	PVC											
3	PVDF											
4	Gyrolok ss											
5	Swagelok ss											
Specials												
0	None											
1	Special											

InTrac 7 

7				/					/					/					/					/					/				
8	9	10	11	12	13	14	15	16	17	18	19	20	21	22	23	24	25	26	27	28	29	30											

- Housings made of Alloy C22 or titanium are supplied with Kalrez® O-rings as a standard
- Housings made of Alloy C22 or titanium are supplied with cap nut made of stainless steel as standard. Flanges are also made of stainless steel and supplied with a sealing plate made of PTFE.
- Varivent and Tri-Clamp flanges are available in stainless steel only.
- Not all configurations are possible.
- Please contact your local METTLER TOLEDO representative for more options.



## 10.6 Product structure InTrac 797 e/InTrac 799 e

<b>Flushing chamber</b>										
9	double flushing chamber									
<b>Electrode/sensor type</b>										
7	pH electrodes with gel-/polymer electrolyte and sensors with Pg 13.5 thread									
9	turbidity sensors									
<b>Operation mode</b>										
M	manual operation									
P	pneumatic operation									
R	pneumatic operation with pneumatic position indication									
I	pneumatic operation with inductive position indication non-Ex									
X	pneumatic operation with inductive position indication Ex									
<b>Insertion length (H)</b>										
1	0	0	H = 100 mm							
<b>Material</b>										
4	4	0	4	DIN 1.4404/AISI 316L						
<b>Process connections</b>										
D	0	0	Ingold DN25 weld-in socket							
T	0	1	Tri-Clamp 1.5"							
T	0	2	Tri-Clamp 2"							
V	0	1	Varivent DN50							
<b>O-ring material</b>										
V	I	Viton®-FDA								
E	p	EPDM-FDA								
K	a	Kalrez®-FDA and USP Class VI								
<b>Body material</b>										
A	PP conductive									
S	DIN 1.4404/AISI 316L									
<b>Flushing connections</b>										
0	without									
1	Serlo ss									
4	Gyrolok ss									
5	Swagelok ss									
<b>Specials</b>										
0	None									
1	Special									

InTrac 7	9			/	1	0	0	/	4	4	0	4	/				/				/			
	8	9	10	11	12	13	14	15	16	17	18	19	20	21	22	23	24	25	26	27	28	29	30	

**Housings with double flushing chamber are only available with DN25, Tri-Clamp or Varivent process connections.**  
 – Please contact your local METTLER TOLEDO representative for more options.





## Sales and Service:

### Australia

Mettler-Toledo Limited  
220 Turner Street, Port Melbourne,  
VIC 3207 Australia  
Phone +61 1300 659 761  
e-mail info.mtaus@mt.com

### Austria

Mettler-Toledo Ges.m.b.H.  
Laxenburger Str. 252/2  
AT - 1230 Wien  
Phone +43 1 607 4356  
e-mail prozess@mt.com

### Brazil

Mettler-Toledo Ind. e Com. Ltda.  
Avenida Tamboré, 418, Tamboré  
BR - 06460-000 Barueri/SP  
Phone +55 11 4166 7400  
e-mail mtbr@mt.com

### Canada

Mettler-Toledo Inc.  
2915 Argenta Rd #6  
CA - ON L5N 8G6 Mississauga  
Phone +1 800 638 8537  
e-mail ProInsideSalesCA@mt.com

### China

Mettler-Toledo International Trading  
(Shanghai) Co. Ltd.  
589 Gui Ping Road, Cao He Jing  
CN - 200233 Shanghai  
Phone +86 21 64 85 04 35  
e-mail ad@mt.com

### Croatia

Mettler-Toledo d.o.o.  
Mandlova 3, HR - 10000 Zagreb  
Phone +385 1 292 06 33  
e-mail mt.zagreb@mt.com

### Czech Republic

Mettler-Toledo s.r.o.  
Trebostická 2283/2  
CZ - 100 00 Praha 10  
Phone +420 226 808 150  
e-mail sales.mtcz@mt.com

### Denmark

Mettler-Toledo A/S  
Naverland 8  
DK - 2600 Glostrup  
Phone +45 43 27 08 00  
e-mail info.mtdk@mt.com

### France

Mettler-Toledo  
Analyse Industrielle S.A.S.  
30, Boulevard de Douaumont  
FR - 75017 Paris  
Phone +33 1 47 37 06 00  
e-mail mtpro-f@mt.com

### Germany

Mettler-Toledo GmbH  
Prozeßanalytik  
Ockerweg 3, DE - 35396 Gießen  
Phone +49 641 507 444  
e-mail prozess@mt.com

### Great Britain

Mettler-Toledo LTD  
64 Boston Road, Beaumont Leys  
GB - Leicester LE4 1AW  
Phone +44 116 235 7070  
e-mail enquire.mtuk@mt.com

### Hungary

Mettler-Toledo Kereskedelmi KFT  
Teve u. 41  
HU - 1139 Budapest  
Phone +36 1 288 40 40  
e-mail order.mt-hu@mt.com

### India

Mettler-Toledo India Private Limited  
Amar Hill, Saki Vihar Road, Powai  
IN - 400 072 Mumbai  
Phone +91 22 4291 0111  
e-mail sales.mtin@mt.com

### Indonesia

PT. Mettler-Toledo Indonesia  
GRHA PERSADA 3<sup>rd</sup> Floor  
Jl. KH. Noer Ali No. 3A  
Kayuringin Jaya  
Kalimalang, Bekasi 17144, ID  
Phone +62 21 294 53919  
e-mail  
mt-id.customersupport@mt.com

### Italy

Mettler-Toledo S.p.A.  
Via Vialba 42  
IT - 20026 Novate Milanese  
Phone +39 02 333 321  
e-mail  
customer-care.italia@mt.com

### Japan

Mettler-Toledo K.K.  
Process Division  
6F Ikenohata Nisshoku Bldg.  
2-9-7, Ikenohata, Taito-ku  
JP - 110-0008 Tokyo  
Phone +81 3 5815 5606  
e-mail helpdesk.ing.jp@mt.com

### Malaysia

Mettler-Toledo (M) Sdn Bhd  
Bangunan Electrocon Holding, U 1-01  
Lot 8 Jalan Astaka U8/84  
Seksyen U8, Bukit Jelutong  
MY - 40150 Shah Alam Selangor  
Phone +60 3 78 44 58 88  
e-mail  
MT-MY.CustomerSupport@mt.com

### Mexico

Mettler-Toledo S.A. de C.V.  
Ejército Nacional #340  
Polanco V Sección  
C.P. 11560  
MX - México D.F.  
Phone +52 55 1946 0900  
e-mail mf.mexico@mt.com

### Norway

Mettler-Toledo AS  
Ulvenveien 92B  
NO - 0581 Oslo Norway  
Phone +47 22 30 44 90  
e-mail info.mtn@mt.com

### Philippines

Mettler-Toledo Philippines Inc.  
6F NOL Towers, Commerce Ave.  
Madrigal Business Park  
Ayala Alabang  
Muntinlupa 1780 Philippines  
Phone +63 2 528 8920  
e-mail  
MT-PH.CustomerSupport@mt.com

### Poland

Mettler-Toledo (Poland) Sp.z.o.o.  
ul. Poleczki 21  
PL - 02-822 Warszawa  
Phone +48 22 440 67 00  
e-mail polska@mt.com

### Russia

Mettler-Toledo Vostok ZAO  
Sretensky blvd. 6/1  
Office 6  
RU - 101000 Moscow  
Phone +7 495 621 56 66  
e-mail inforus@mt.com

### Singapore

Mettler-Toledo (S) Pte. Ltd.  
Block 28  
Ayer Rajah Crescent # 05-01  
SG - 139959 Singapore  
Phone +65 6890 00 11  
e-mail  
mt.sg.customersupport@mt.com

### Slovakia

Mettler-Toledo s.r.o.  
Hattalova 12/A  
SK - 831 03 Bratislava  
Phone +421 2 4444 1221  
e-mail predaj@mt.com

### Slovenia

Mettler-Toledo d.o.o.  
Pot heroja Trtnika 26  
SI - 1261 Ljubljana-Dobrunje  
Phone +386 1 547 49 05  
e-mail darko.divjak@mt.com

### South Korea

Mettler-Toledo (Korea) Ltd.  
1 & 4 F, Yeil Building 21  
Yangjaecheon-ro 19-gil  
Seocho-Gu, Seoul 06753 Korea  
Phone +82 2 3498 3500  
e-mail Sales\_MTKR@mt.com

### Spain

Mettler-Toledo S.A.E.  
C/Miguel Hernández, 69 - 71  
ES - 08908 L'Hospitalet de Llobregat  
(Barcelona)  
Phone +34 902 32 00 23  
e-mail mtemkt@mt.com

### Sweden

Mettler-Toledo AB  
Virkesvägen 10  
Box 92161  
SE - 12008 Stockholm  
Phone +46 8 702 50 00  
e-mail sales.mts@mt.com

### Switzerland

Mettler-Toledo (Schweiz) GmbH  
Im Langacher, Postfach  
CH - 8606 Greifensee  
Phone +41 44 944 47 47  
e-mail ProSupport.ch@mt.com

### Thailand

Mettler-Toledo (Thailand) Ltd.  
272 Soi Soonvijai 4  
Rama 9 Rd., Bangkapi  
Huay Kwang  
TH - 10320 Bangkok  
Phone +66 2 723 03 00  
e-mail  
MT-TH.CustomerSupport@mt.com

### Turkey

Mettler-Toledo Türkiye  
Haluk Türksöy Sokak No: 6 Zemin ve 1.  
Bodrum Kat  
34662 Üsküdar - İstanbul, TR  
Phone +90 216 400 20 20  
e-mail sales.mttr@mt.com

### USA

METTLER TOLEDO  
Process Analytics  
900 Middlesex Turnpike, Bld. 8  
Billerica, MA 01821, USA  
Phone +1 781 301 8800  
Freephone +1 800 352 8763  
e-mail mtprous@mt.com

### Vietnam

Mettler-Toledo (Vietnam) LLC  
G Floor, SCS Building, Plot T2-4  
D1 Street, Saigon Hi-tech Park  
Tan Phu Ward, District 9  
Ho Chi Minh City, Vietnam  
Phone +84 28 73 090 789  
e-mail  
MT-VN.CustomerSupport@mt.com



Management System  
certified according to  
ISO 9001 / ISO 14001

Subject to technical changes.  
© METTLER TOLEDO. All rights reserved.  
04/2018. Printed in Switzerland. 52 403 124 B

Mettler-Toledo GmbH, Process Analytics  
Im Hackacker 15, CH-8902 Urdorf, Switzerland  
Phone + 41 44 729 62 11, Fax +41 44 729 66 36

[www.mt.com/pro](http://www.mt.com/pro)