



**EDS440-L/-S**  
**EDS441-L/-S**  
**EDS441-LAB-4**  
**EDS440-LAF-4**



Insulation fault locator  
to locate insulation faults  
in ungrounded DC, AC and  
three-phase power supplies  
(IT systems)

From serial number: 2000...

PLEASE READ THIS MANUAL AND ANY ACCOMPANYING DOCUMENTS CAREFULLY  
AND KEEP THEM IN A SECURE PLACE FOR FUTURE REFERENCE.



**Bender GmbH & Co. KG**

Postfach 1161 • 35301 Grünberg • Germany  
Londorfer Straße 65 • 35305 Grünberg • Germany

Tel.: +49 6401 807-0  
Fax: +49 6401 807-259

E-Mail: [info@bender.de](mailto:info@bender.de)  
Web: [www.bender.de](http://www.bender.de)

Customer service  
Service-Hotline: 0700-BenderHelp (Telephone and Fax)  
Carl-Benz-Straße 8 • 35305 Grünberg • Germany

Tel.: +49 6401 807-760  
Fax: +49 6401 807-629

E-Mail: [info@bender-service.com](mailto:info@bender-service.com)

© Bender GmbH & Co. KG  
All rights reserved.  
Reproduction only with permission  
of the publisher.  
Subject to change.

<b>1. Important information</b> .....	<b>5</b>	<b>5. Mounting</b> .....	<b>14</b>
1.1 How to use this manual .....	5	5.1 General instructions .....	14
1.2 Technical support .....	5	5.2 Installation clearances .....	14
1.2.1 End customer support and advice .....	5	5.3 Screw mounting .....	15
1.2.2 Repair .....	5	5.4 DIN rail mounting .....	15
1.2.3 Customer service .....	5	5.5 Connection of the BB bus .....	16
1.3 Training courses .....	6	5.6 Connection to the voltage supply .....	16
1.4 Delivery conditions .....	6	5.7 Connection of the X1 interface .....	17
1.5 Storage .....	6	5.8 Connection of the relays .....	17
1.6 Warranty and liability .....	6	5.9 BS bus termination .....	17
1.7 Disposal .....	6	5.10 Connection of the X2 interface (k1-12 / I1-12) .....	17
<b>2. Safety instructions</b> .....	<b>7</b>	5.10.1 Connection of CTAC series measuring current transformers .....	18
2.1 General safety instructions .....	7	5.10.2 Connection of CTBC... series to EDS441-LAB-4 .....	18
2.2 Work activities on electrical installations .....	7	5.10.3 Connection of CTAF...SET series measuring current transformers to EDS440-LAF-4 .....	19
2.3 Device-specific safety information .....	7	5.11 Wiring diagram to DC system with ISOMETER® iso685-D-P .....	20
2.4 Intended use .....	7	5.12 Wiring diagram to AC system with ISOMETER® iso685-D-P .....	21
2.5 Requirements for reliable insulation fault location .....	8	5.13 Wiring diagram to 3(N)AC system with ISOMETER® iso685-D-P .....	22
2.6 Periodic verification .....	8	5.14 Connection example: ISOMETER® iso685-D-P, EDS440-S, IOM441-S and EDS440-L .....	23
<b>3. Function</b> .....	<b>9</b>	<b>6. Display and alarm messages</b> .....	<b>24</b>
3.1 Features .....	9	6.1 Operating and display elements EDS44x-S .....	24
3.1.1 Areas of application .....	9	6.2 Operating and display elements EDS44x-L .....	24
3.1.2 Standards .....	9	6.3 Standard display in the operating mode .....	25
3.1.3 System variants .....	9	6.3.1 Standard display EDS44x-S .....	25
3.1.4 System properties .....	9	6.3.2 Standard display EDS44x-L .....	25
3.1.5 Compatibility .....	9	6.4 Alarm messages .....	25
3.2 Operating principle of the EDS system .....	10	6.4.1 Insulation fault (ALARM IΔL) .....	25
3.3 Schematic diagram EDS system .....	11	6.4.2 Residual current exceeded (ALARM IΔn) .....	25
<b>4. Device overview</b> .....	<b>12</b>	6.4.3 Connection fault of the current transformers .....	26
4.1 External dimensions EDS44x-x and IOM441-S .....	12	6.4.4 Device error, BB bus error .....	26
4.2 View EDS440-S .....	12	6.4.5 Device error, failure BS bus master .....	26
4.3 View EDS440-L .....	12	6.4.6 Error message .....	27
4.4 Connections and control panel EDS44x-L .....	13	6.4.7 Acoustic alarm message .....	27
4.5 Connections and control panel EDS44x-S .....	13		

<b>7. Commissioning</b>	<b>28</b>
7.1 Before switching on	28
7.2 Switching on	28
7.3 Steps for commissioning ISOMETER® and EDS44x	29
<b>8. Device communication</b>	<b>30</b>
8.1 BS bus	30
8.1.1 Master-slave principle	30
8.1.2 Addresses and address ranges on the BS bus	30
8.1.3 RS-485 specifications/cables	30
8.1.4 Cable routing	30
8.2 Modbus RTU	30
<b>9. Operation</b>	<b>31</b>
9.1 Reading out and setting the BS address	31
9.1.1 Reading out a BS address	31
9.1.2 Setting a BS address	31
9.1.3 Extended address range (offset = 80)	32
9.2 Display and change of transmission protocols	32
9.2.1 Displaying the current transmission protocol	32
9.2.2 Changing the transmission protocol	32
9.3 Resetting saved alarm messages (RESET button)	33
9.4 Deactivating the buzzer and resetting the fault message	33
9.5 Running a test (TEST button)	33
<b>10. Settings</b>	<b>34</b>
10.1 EDS settings on the ISOMETER®	34
10.1.1 Locating current injector settings	34
10.1.2 Trigger function	34
10.1.3 Fault memory	35
10.2 Settings of inputs and outputs of the EDS44x-L	35
10.2.1 Digital inputs of the EDS44x-L (I1, I2)	35
10.2.2 Digital outputs of the EDS44x-L	36
10.3 Factory settings	37

<b>11. Alarm messages</b>	<b>38</b>
<b>12. Diagrams</b>	<b>39</b>
12.1 Response sensitivity curves	39
12.1.1 Characteristic curves EDS440 for 3AC systems	40
12.1.2 Characteristic curves EDS440 for AC systems	41
12.1.3 Characteristic curves EDS440 for DC systems	42
12.1.4 Characteristic curves EDS441 for AC systems	44
12.1.5 Characteristic curves EDS441 for DC systems	45
12.1.6 Characteristic curves EDS441-LAB for AC systems	46
12.1.7 Characteristic curves EDS441-LAB for DC systems	47
12.1.8 Response values EDS440-LAF for DC systems up to a system leakage capacitance of max. 100 µF	48
12.1.9 Response values EDS440-LAF for AC systems up to a system leakage capacitance of max. 100 µF	48
12.2 Fault curve EDS440	48
12.3 Fault curve EDS441	49
<b>13. Technical data</b>	<b>50</b>
13.1 Tabular data	50
13.2 Standards and certifications	52
13.3 Ordering details	52
13.3.1 Insulation fault locators	52
13.3.2 Accessories	53
13.3.3 Measuring current transformers for EDS440	53
13.3.4 Changelog	54
<b>Index</b>	<b>55</b>

# 1. Important information

## 1.1 How to use this manual



This manual is intended for **qualified personnel** working in electrical engineering and electronics!



Read the manual **before** you begin to mount, connect, and commission the unit. Always keep the manual within easy reach for future reference following commissioning.

To make it easier for you to understand and revisit certain sections in this manual, we have used symbols to identify important instructions and information. The meaning of these symbols is explained below.



This signal word indicates that there is a **high risk of danger** that will result in **electrocution** or **serious injury** if not avoided.



This signal word indicates a **medium risk of danger** that can lead to **death** or **serious injury** if not avoided.



This signal word indicates a **low-level risk** that can result in **minor or moderate injury** or **damage to property** if not avoided.



This symbol denotes information intended to assist the user in making **optimum use** of the product.

## 1.2 Technical support

### 1.2.1 End customer support and advice

Technical support by phone or e-mail for all Bender products

- Questions concerning specific customer applications
- Commissioning
- Troubleshooting

**Telephone:** +49 6401 807-760 (365 days from 07:00 - 20:00 Uhr [MEZ/UTC +1])

**Fax:** +49 6401 807-259

0700BenderHelp (Tel. and Fax in Germany only)

**E-mail:** support@bender.de

### 1.2.2 Repair

Repair, calibration, update and replacement service for Bender products

- Repairing, calibrating, testing and analysing Bender products
- Hardware and software update for Bender devices
- Delivery of replacement devices
- Extended guarantee, in-house repair service, replacement devices at no extra cost

**Telephone:** +49 6401 807-780\* (technical issues)

+49 6401 807-784\*, -785\* (sales)

**Fax:** +49 6401 807-789

**E-mail:** repair@bender.de

Please send the devices for **repair** to the following address:

Bender GmbH, Repair-Service,  
Londorfer Strasse 65,  
35305 Grünberg

### 1.2.3 Customer service

On-site service for all Bender products

- Commissioning, parameter setting, maintenance, troubleshooting
- Analysis of the electrical installation in the building (power quality test, EMC test, thermography)
- Training courses for customers

**Telephone:** +49 6401 807-752\*, -762\* (technical issues)/

+49 6401 807-753\* (sales)

**Fax:** +49 6401 807-759

**E-mail:** fieldservice@bender.de

**Internet:** www.bender.de

\* Mo-Thu 07:00 a.m. - 16:00 p.m. , Fr 07:00 a.m. - 13:00 p.m.

### 1.3 Training courses

Bender is happy to provide training regarding the use of test equipment. The dates of training courses and workshops can be found on the Internet at

***[www.bender.de](http://www.bender.de) -> Know-how -> Seminars.***

### 1.4 Delivery conditions

Bender sale and delivery conditions apply.

For software products, the "Softwareklauseel zur Überlassung von Standard-Software als Teil von Lieferungen, Ergänzung und Änderung der Allgemeinen Lieferbedingungen für Erzeugnisse und Leistungen der Elektroindustrie" (software clause in respect of the licensing of standard software as part of deliveries, modifications and changes to general delivery conditions for products and services in the electrical industry) set out by the ZVEI (Zentralverband Elektrotechnik- und Elektronikindustrie e.V.) (German Electrical and Electronic Manufacturers' Association) also applies. Amending the "General Conditions for the supply of Products and Services of the Electrical and Electronics Industry" (GL)\*

Sale and delivery conditions can be obtained from Bender in printed or electronic format.

### 1.5 Storage

The devices must only be stored in areas where they are protected from dust, damp, and spray and dripping water, and in which the specified storage temperatures can be ensured.

### 1.6 Warranty and liability

Warranty and liability claims in the event of injury to persons or damage to property are excluded if they can be attributed to one or more of the following causes:

- Improper use of the device.
- Incorrect mounting, commissioning, operation and maintenance of the device.
- Failure to observe the instructions in this operating manual regarding transport, commissioning, operation and maintenance of the device.
- Unauthorised changes to the device made by parties other than the manufacturer.
- Non-observance of technical data.
- Repairs carried out incorrectly and the use of replacement parts or accessories not approved by the manufacturer.
- Catastrophes caused by external influences and force majeure.
- Mounting and installation with device combinations not recommended by the manufacturer.

This operating manual, especially the safety instructions, must be observed by all personnel working on the device. Furthermore, the rules and regulations that apply for accident prevention at the place of use must be observed.

### 1.7 Disposal

Abide by the national regulations and laws governing the disposal of this device. Ask your supplier if you are not sure how to dispose of the old equipment.

The directive on waste electrical and electronic equipment (WEEE directive) and the directive on the restriction of certain hazardous substances in electrical and electronic equipment (RoHS directive) apply in the European Community. In Germany, these policies are implemented through the "Electrical and Electronic Equipment Act" (ElektroG). According to this, the following applies:

- Electrical and electronic equipment are not part of household waste.
- Batteries and accumulators are not part of household waste and must be disposed of in accordance with the regulations.
- Old electrical and electronic equipment from users other than private households which was introduced to the market after 13 August 2005 must be taken back by the manufacturer and disposed of properly.

For more information on the disposal of Bender devices, refer to our homepage at

***[www.bender.de](http://www.bender.de) -> Service & Support.***

## 2. Safety instructions

### 2.1 General safety instructions

Part of the device documentation in addition to this manual is the enclosed "Safety instructions for Bender products".

### 2.2 Work activities on electrical installations



Only **qualified personnel** are permitted to carry out the work necessary to install, commission and run a device or system.



**DANGER**

#### **Risk of electrocution due to electric shock!**

Touching live parts of the system carries the risk of:

- An electric shock
- Damage to the electrical installation
- Destruction of the device

**Before installing and connecting the device, make sure that the installation has been de-energised.** Observe the rules for working on electrical installations.

If the device is used outside the Federal Republic of Germany, the applicable local standards and regulations must be complied with. The European standard EN 50110 can be used as a guide.

### 2.3 Device-specific safety information



**WARNING**

Make sure that the basic settings meet the requirements of the IT system. Children and the public must not have access to and contact with the EDS44x.



**CAUTION**

#### **Make sure that the operating voltage is correct!**

Prior to insulation and voltage tests, the EDS44x must be disconnected from the IT system for the duration of the test. In order to check the correct connection of the device, a function test has to be carried out before starting the system.

The EDS440-x and EDS441-x are built in accordance with state-of-the-art technology and the recognised safety regulations. However, the use of such devices may introduce risks to the life and limb of the user or third parties and/or result in damage to the EDS44x or other property.

Use the EDS44x only:

- As intended
- In perfect working order

Immediately rectify any faults that may endanger safety. Do not make any unauthorised changes and only purchase spare parts and optional accessories recommended by the manufacturer of the devices. Failure to observe this requirement can result in fire, electric shock and injury.

Unauthorised persons must not have access to or contact with the EDS44x.

Reference signs must always be clearly legible. Replace damaged or illegible signs immediately.

### 2.4 Intended use



**CAUTION**

#### **Risk of malfunctions due to excessive locating current on sensitive system parts!**

An excessive locating current flowing between the IT system and earth may cause controller faults in sensitive system parts, such as PLC or relays. Ensure that the level of the locating current is compatible with the system to be monitored.

EDS44x insulation fault locators are used to locate insulation faults in unearthed DC, AC and three-phase power supply systems (IT systems). Depending on the locating current injector, AC and three-phase systems can be monitored within the range from AC 42 to 1000 V; DC systems, within the range from DC 24 to 1500 V. An AC residual current can be indicated in the range 42 Hz...1 kHz, 100 mA...20 A (EDS440) or 42 Hz...60 Hz, 100 mA...2 A (EDS441).

Devices of the EDS44x series comply with the product standard IEC 61557-9.

An EDS system (insulation fault location system) consists of an EDS44x insulation fault locator and a locating current injector. EDS44x insulation fault locators detect locating current signals generated by the locating current injector via measuring current transformers and evaluate them accordingly.

12 measuring current transformers can be connected for each EDS44x. Up to 50 EDS44x can be linked via BS bus (Bender sensor bus, RS-485 interface with BS protocol) and thereby, up to 600 outgoing circuits can be monitored.

The scanning time for all measuring channels is at least 6 seconds, depending on the profile.

Intended use also implies:

- The observation of all information in the operating manual
- Compliance with test intervals

In order to meet the requirements of applicable standards, customised parameter settings must be made on the equipment in order to adapt it to local equipment and operating conditions. Please heed the limits of the area of application indicated in the technical specifications.

Any other use than that described in this manual is regarded as improper.

## 2.5 Requirements for reliable insulation fault location

The EDS44x has the task of locating the insulation fault downstream of the measuring current transformer  $R_{Fd}$ . To do this, it must reliably detect the locating current caused by the insulation fault. This is only possible under the following conditions:

- One current transformer must be connected to each activated channel.
- The locating current  $I_L$  is within the specific range. See chapter 14, Technical data
- The upstream capacitances  $C_{Lu}$  must be at least as high as the downstream capacitances  $C_{Ld}$ .
- The system leakage capacitance must not be too high (refer to ["Diagrams" on page 39](#))
- The residual current can be within the following range: 100 mA...10 A (EDS440) or 100 mA...1 A (EDS441).
- Along with the amplitude, the frequency of the residual current influences the reliable detection of the locating current. With regard to this, observe the ["Fault curve EDS440" on page 49](#) and the ["Fault curve EDS441" on page 49](#).

## 2.6 Periodic verification

The EDS system monitors itself during operation.

We recommend to activate the test function on each connected EDS44x regularly. There are several ways to start a test:

- Select standard display and then press the "TEST" button on the front panel of the EDS44x
- Press an external TEST button connected to the EDS44x
- Send a TEST command from an iso685 device via the BS bus.

Observe the applicable national and international standards, which require regular testing of electrical equipment.



## 3.1 Features

### 3.1.1 Areas of application

- Insulation fault location in AC, 3(N)AC and DC IT systems
- Main circuits and control circuits in industrial plants and ships
- Diode-decoupled DC IT systems in power plants
- Systems for medical locations

### 3.1.2 Standards

The standard for unearthed power supplies (IT systems) DIN VDE 0100-410 (VDE 0100-410):2007-06 (IEC 60364-4-41:2005, modified) requires that the first insulation fault is to be eliminated with the shortest practicable delay. EDS systems enable fast localisation of this insulation fault.

### 3.1.3 System variants

The insulation fault locators EDS440-x and EDS441-x differ depending on their response sensitivity. The EDS440-x is suitable for main circuits.

The EDS441-x can be used in control circuits and in circuits in medical locations.

	-L	-S	-LAB-4	-LAF-4
<b>EDS 440</b>	Channel LED BS bus $I_{\Delta L} = 2 \dots 10 \text{ mA}$ Main circuits Digital inputs and outputs	No channel LED BB bus $I_{\Delta L} = 2 \dots 10 \text{ mA}$ Main circuits No internal voltage supply		Channel LED BS bus $I_{\Delta L} = 10 \text{ mA}^{**}$ Main circuits Digital inputs and outputs
<b>EDS 441</b>	Channel LED BS bus $I_{\Delta L} = 0.2 \dots 1 \text{ mA}$ Control circuits Digital inputs and outputs	No channel LED BB bus $I_{\Delta L} = 0.2 \dots 1 \text{ mA}$ Control circuits No internal voltage supply	Channel LED BS bus $I_{\Delta L} = 0.2 \dots 1 \text{ mA}^*$ Control circuits W...AB current transformers Digital inputs and outputs	

\* High response sensitivity with large system leakage capacitances

\*\* In combination with CTAF...SET series measuring current transformers

### 3.1.4 System properties

- Universal system concept
- Modular design, therefore easily adjustable to the given circumstances
- Measuring current transformers available in various sizes and versions
- CT connection monitoring
- 12 measuring channels for series W..., WR..., WS... measuring current transformers
- Optional extension by 12 relay channels
- Fault memory behaviour selectable
- Up to 50 EDS insulation fault locators in the system, 600 measuring channels
- Response sensitivity: EDS440 2...10 mA, EDS441 0.2...1 mA
- AC residual current measurement with configurable response value
- Two alarm relays with one N/O contact each
- N/O or N/C operation selectable
- External test/reset button
- Central display of faulty outgoing circuits
- Serial interface RS-485, BS bus address range 2...79
- Connection to higher-level control and visualisation systems possible.

### 3.1.5 Compatibility

Legend:

BS bus: Full compatibility, communication via BS bus

BB bus: Full compatibility, communication via BB bus

◇ = Full compatibility, no communication possible

# = Limited compatibility + communication via BS bus  
Limited display of messages on the device.  
Limited parameterisation via the device possible.

! = Limited compatibility + communication via BS bus  
Display of all messages on the device.  
No parameter setting via the device possible.

### 3.1.5.1 Combination of insulation fault locators

Device	EDS440-L	EDS440-S	EDS441-L	EDS441-S	EDS441-LAB	EDS440-LAF
EDS440-L	BS bus	◇				
EDS440-S	◇	BB bus				
EDS441-L			BS bus	◇		
EDS441-S			◇	BB bus		
EDS441-LAB					BS bus	
EDS441-LAF						BS bus
EDS460/490L	BS bus	◇				
EDS460/490D	BS bus	◇				
EDS461/491L			BS bus	◇		
EDS461/491D			BS bus	◇		
EDS150	BS bus	◇				
EDS151			BS bus	◇		
EDS195P	◇	◇	◇	◇		

### 3.1.5.2 Current transformers and measuring clamps

Device	Type	EDS440-L/S	EDS441-L/S	EDS441-LAB	EDS440-LAF
W.../WR.../ WS...	Type A	◇			
W/WS 8000	Type A		◇	◇	
W...AB	Type AB			◇	
CTAF...SET	Type A				◇

### 3.1.5.3 Other Bender devices

Device	EDS440-L	EDS440-S	EDS441-L	EDS441-S	EDS441-LAB	EDS440-LAF
COM460	!		!		!	!
COM465	!		!		!	!
IOM441-S	!	!	!	!	!	!
CP700	!		!		!	!
MK2430	#		#			
IRDH575	#		#			
iso685-x-p	BS bus	BB bus	BS bus	BB bus	BS bus	BS bus
isoMED427			◇			
PGH183			◇	◇		
PGH185	◇	◇				
PGH186	◇	◇				

## 3.2 Operating principle of the EDS system

When an insulation monitoring device detects the occurrence of an insulation fault, it starts the insulation fault location.

In the event of a first insulation fault, an undefined residual current flows in IT systems, which is primarily defined by the system leakage capacitances and the value of the insulation fault. The basic idea of insulation fault location is therefore generating a defined locating current  $I_L$  that flows through the insulation fault. The locating current is driven by the system voltage and can be located in the faulty outgoing circuit using the measuring current transformer.

The locating current is generated by the locating current injector. It is limited in amplitude and time. The amplitude depends on the size of the existing insulation fault and the system voltage. It is limited depending on the settings.

The locating current flows from the locating current injector via the live lines to the insulation fault position taking the shortest way. From there, it flows through the insulation fault and the PE back to the locating current injector. This locating current pulse is detected by the measuring current transformers on the insulation fault path and signalled by the connected insulation fault locator.

Locating pulse pattern:

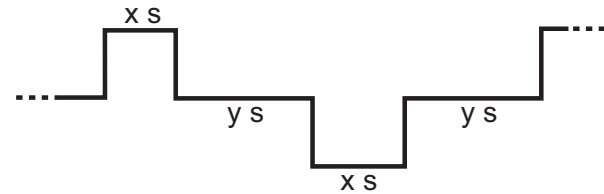

The length of the pulse and pause intervals depends on the system conditions ( $R_F$ ,  $C_e$ ).

For further information, refer to the data sheet "Technical aspects

main catalogue part 1" in the chapter "Technical aspects when using insulation fault location systems".



#### Measured value depending on the system leakage capacitance

The influence of system leakage capacitances may cause false indication of the locating current.

The locating current of the locating current injector is limited. Due to this limitation, the resistance of the insulation fault may be lower than the value signalled by the indicated locating current.

#### Project planning

During project planning it must be observed that there are no system parts where the locating current can cause harmful reactions even in unfavourable cases.

#### Symmetrical insulation faults

Under certain conditions, symmetrical insulation faults located downstream of the measuring current transformer are not detected. Low-frequency residual currents (e.g. caused by converters) may prevent insulation faults from being detected if their frequency is identical or almost identical to the test pulse frequency of the locating current injector.

#### Influence by other components

The insulation fault location can be disturbed by components, loads or EMC influences within an IT system. Thus, secure localisation may not be possible under all circumstances or false tripping may occur.

### 3.3 Schematic diagram EDS system

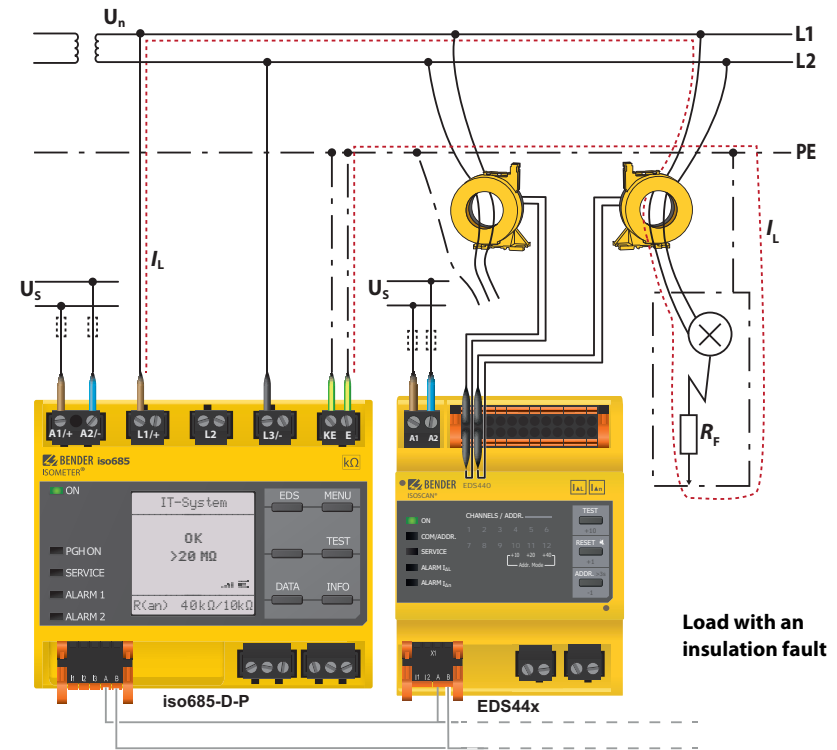

#### Legend

EDS44x	Insulation fault locator
iso685-D-P	Insulation monitoring device with an integrated locating current injector
$U_n$	Voltage source IT system
$U_s$	Supply voltage
W	Measuring current transformers
$I_L$	Locating current
$R_F$	Insulation fault downstream of the measuring current transformer
PE	Protective earth conductor or equipotential bonding conductor
BS bus	BS bus for device communication

## 4. Device overview

### 4.1 External dimensions EDS44x-x and IOM441-S

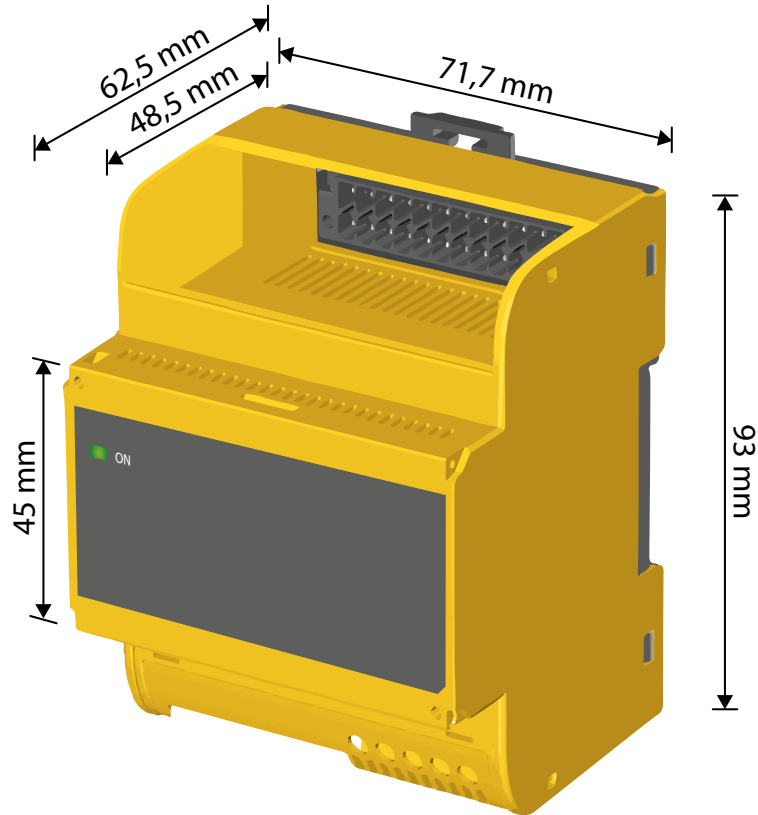

### 4.2 View EDS440-S

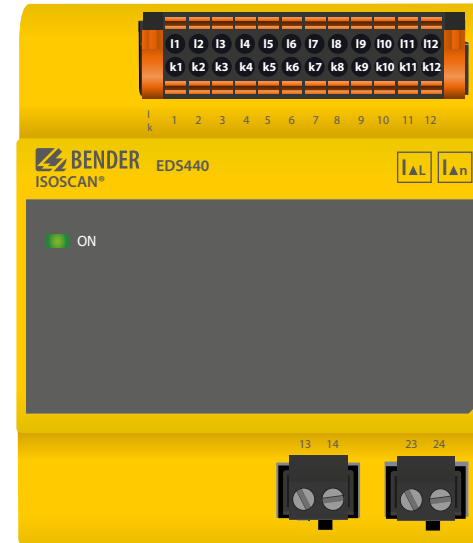

### 4.3 View EDS440-L



### 4.4 Connections and control panel EDS44x-L

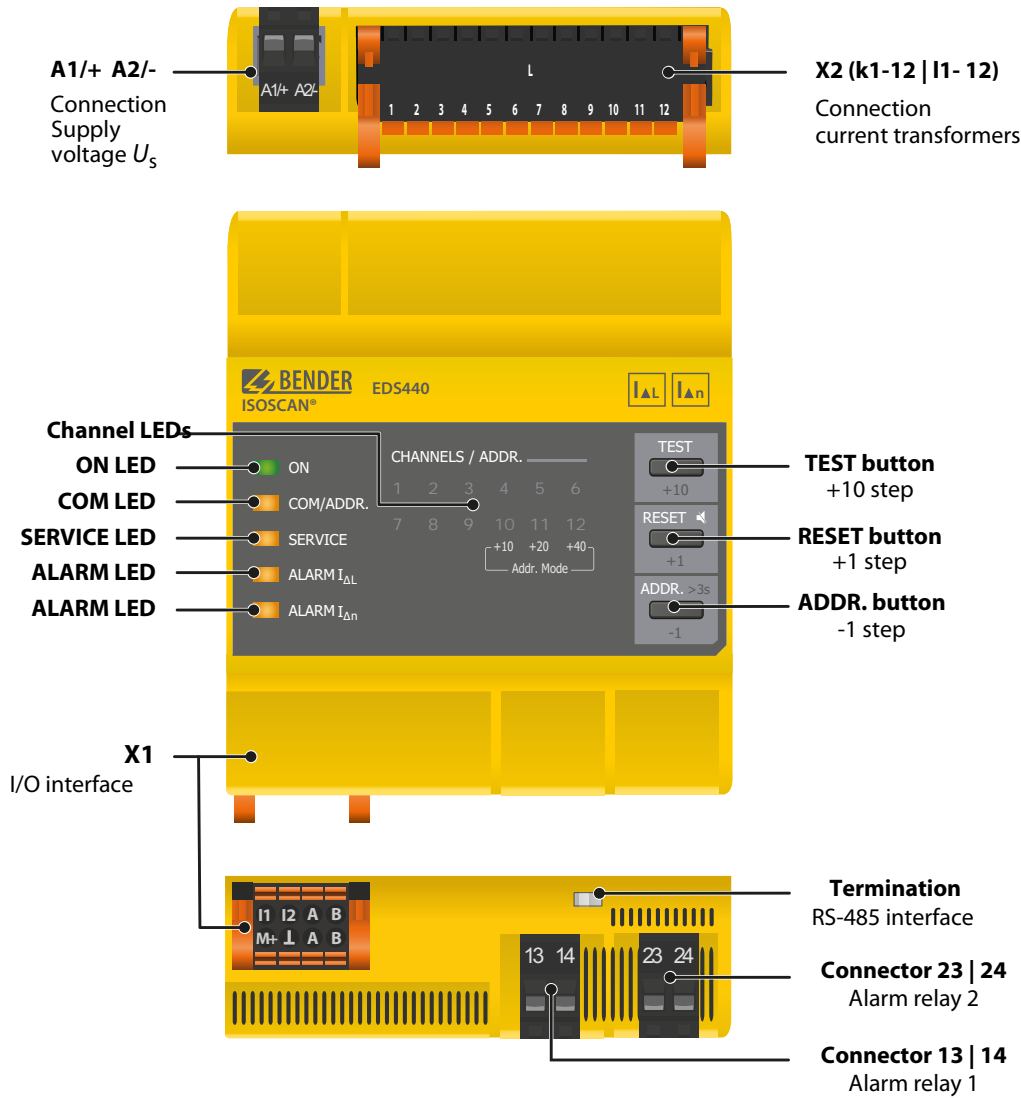

### 4.5 Connections and control panel EDS44x-S

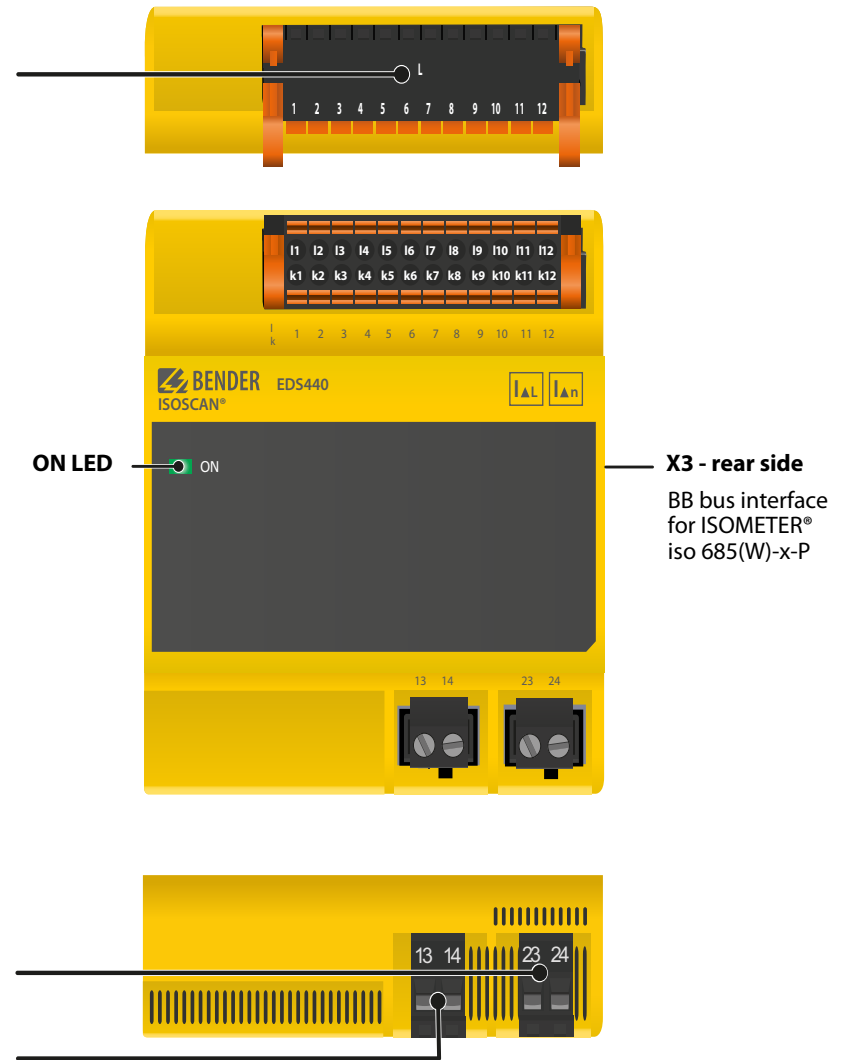

## 5. Mounting

### 5.1 General instructions



Only **qualified personnel** are permitted to carry out the work necessary to install, commission and run a device or system.



**DANGER**

#### **Risk of electrocution due to electric shock!**

Touching live parts of the system carries the risk of:

- An electric shock
- Damage to the electrical installation
- Destruction of the device

**Before mounting and connecting the device, make sure that the installation has been de-energised.** Observe the rules for working on electrical installations.



#### **Cable lengths**

Install the measuring current transformers according to the instructions in the respective data sheet of the measuring current transformer. When connecting the measuring current transformers, it is essential that the maximum cable lengths are observed.

#### **Application in railway vehicles/DIN EN 45545-2:2016**

If the horizontal or vertical distance to adjacent components which do not meet the requirements in table 2 of DIN EN 45545-2 is less than 20 mm or less than 200 mm respectively, they are to be regarded as grouped. Refer to DIN EN 45545-2 chapter 4.3 Grouping rules.

The devices are suitable for the following installation methods:

- Distribution panels according to DIN 43871
- Quick DIN rail mounting according to IEC 60715
- Screw mounting using M4 screws

### 5.2 Installation clearances

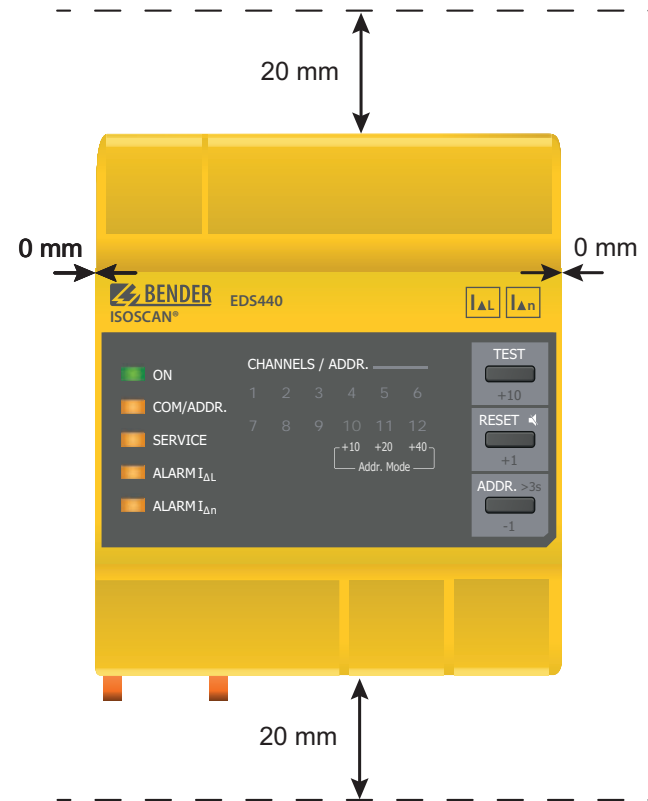

### 5.3 Screw mounting

1. Fix the two mounting clips provided with the device manually or using a tool as illustrated below.
2. Drill the mounting holes for the M4 thread according to the dimensioned drilling template.
3. Fix the EDS44x using two M4 screws.

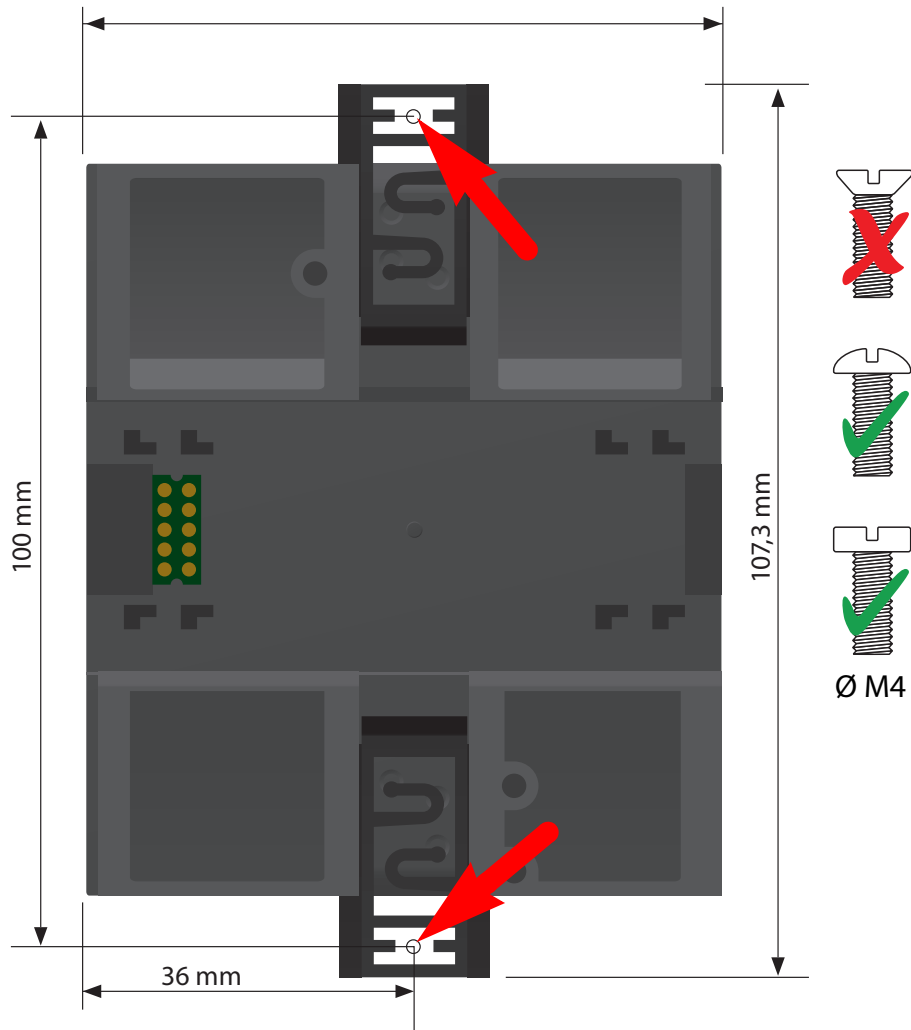

### 5.4 DIN rail mounting

1. Fix one of the provided mounting clips manually or using a tool as illustrated below.
2. Snap the EDS44x securely on the DIN rail.
3. Push the mounting clip until it clicks into place.

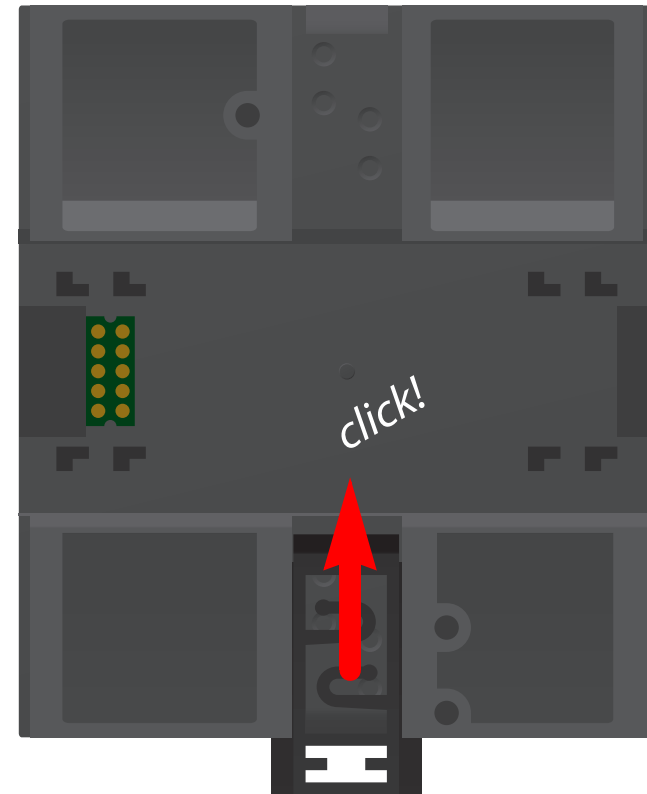

## 5.5 Connection of the BB bus

The BB bus is an interface that enables Bender devices to communicate with each other. The BB bus can be used with an ISOMETER® and a maximum of two EDS44x or one EDS44x-S and one IOM44-S. For this purpose, the BB bus is installed at the rear side of both devices and afterwards, both devices are mounted next to each other on the DIN rail. For further information, refer to the quick-start guide enclosed to the BB bus PCBs.

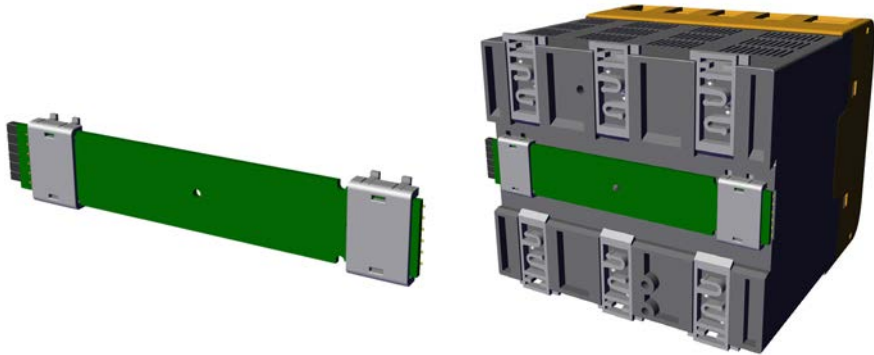

### Voltage supply via BB bus

Sensor variants that are additionally connected to the ISOMETER®, e.g. EDS44x-S, do not require additional supply voltage when the devices are connected to the BB bus via X3.

### Number of devices to be connected

A maximum of two EDS44x-S or one EDS44x-S with one IOM44-S can be connected to an ISOMETER®.

### Mounting

When the BB bus is mounted, the EDS44x must always be mounted on the right side of the ISOMETER®.

### Error codes

In the case of the EDS44x-L variant, error codes of the BB bus are indicated by means of a combination of the SERVICE LED and various flashing channel LEDs. See "[Device error, BB bus error](#)" on page 26.

## 5.6 Connection to the voltage supply

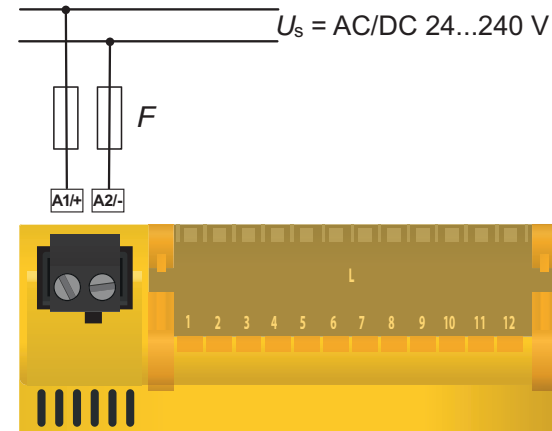

### Back-up fuse voltage supply

If the device is supplied via an external power supply unit, the back-up fuse  $F_{back-up}$  at connection "A1/+ A2/-" must be selected in such a way that the feeding power supply unit is able to trip the DC-compatible back-up fuse.

Example: A back-up fuse of 650 mA/T is recommended when using a 24-V power supply unit (min. 1 A).



### 5.7 Connection of the X1 interface

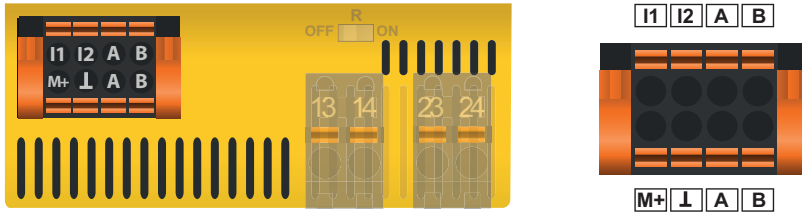

<b>I1</b>	Input 1	<b>M+</b>	Dig. current output
<b>I2</b>	Input 2	<b>⊥</b>	Ground
<b>A</b>	RS-485 A (input)	<b>A</b>	RS-485 A (output)
<b>B</b>	RS-485 B (input)	<b>B</b>	RS-485 B (output)



The EDS44x-L is connected via the X1 plug.  
The EDS44x-S does not feature an X1 interface and can only be connected via the BB bus.

### 5.8 Connection of the relays

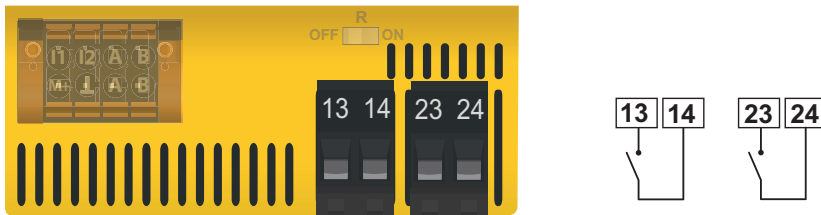

<b>Alarm relay 1</b>	<b>13</b>	N/O contact	<b>Alarm relay 2</b>	<b>23</b>	N/O contact
	<b>14</b>			<b>24</b>	

### 5.9 BS bus termination

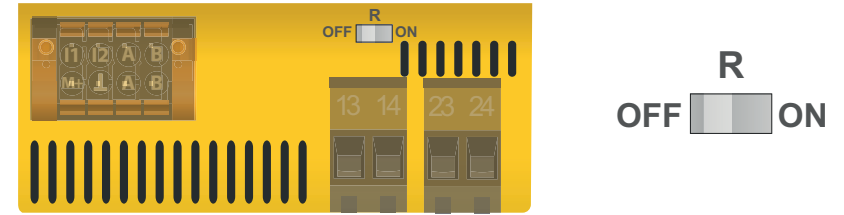

Activating a terminating resistor to define the first and the last device in the bus system.

<b>ON</b>	First and last device in a bus	<b>OFF</b>	All devices between the first and the last device in the bus
-----------	--------------------------------	------------	--

### 5.10 Connection of the X2 interface (k1-12 / I1-12)

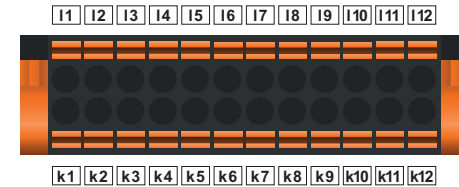

<b>I1</b>	Measuring CT 1	<b>k1</b>
<b>I2</b>	Measuring CT 2	<b>k2</b>
<b>I3</b>	Measuring CT 3	<b>k3</b>
<b>I4</b>	Measuring CT 4	<b>k4</b>
...	...	...
<b>I12</b>	Measuring CT 12	<b>k12</b>

### 5.10.1 Connection of CTAC series measuring current transformers

For insulation fault location, the measuring current transformers of the CTAC series are used.

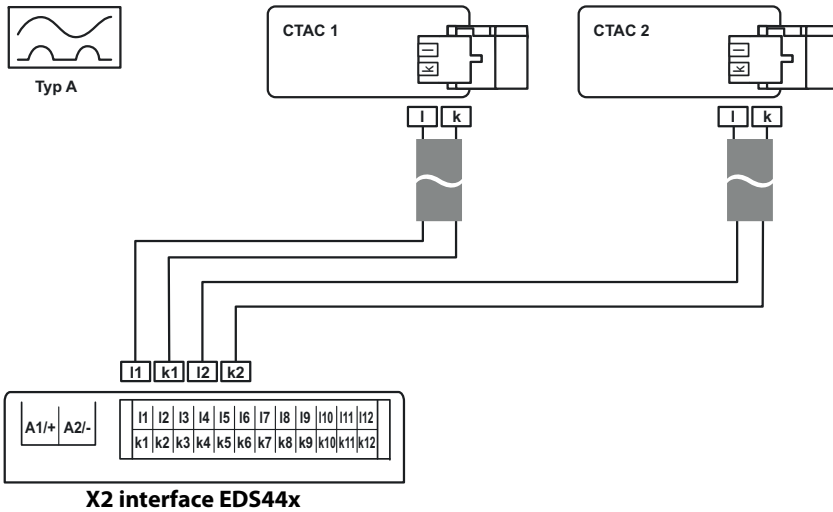

#### Connection of CTAC series measuring current transformers

Terminals 1 and 2 as well as terminals 3 and 4 of the measuring current transformer are bridged internally. The connections k and I must not be interchanged on the EDS44x.

#### Live conductors and measuring current transformers

You must ensure that all live conductors are routed through the measuring current transformer. Do not route any existing PE conductors or shields of shielded cables through the measuring current transformer! Standard measuring current transformers are not suitable for the EDS44x system and must not be used. An accurate measurement result can only be obtained if these notes are observed.

For further information regarding measuring current transformers, refer to the respective data sheets.

### 5.10.2 Connection of CTBC... series to EDS441-LAB-4

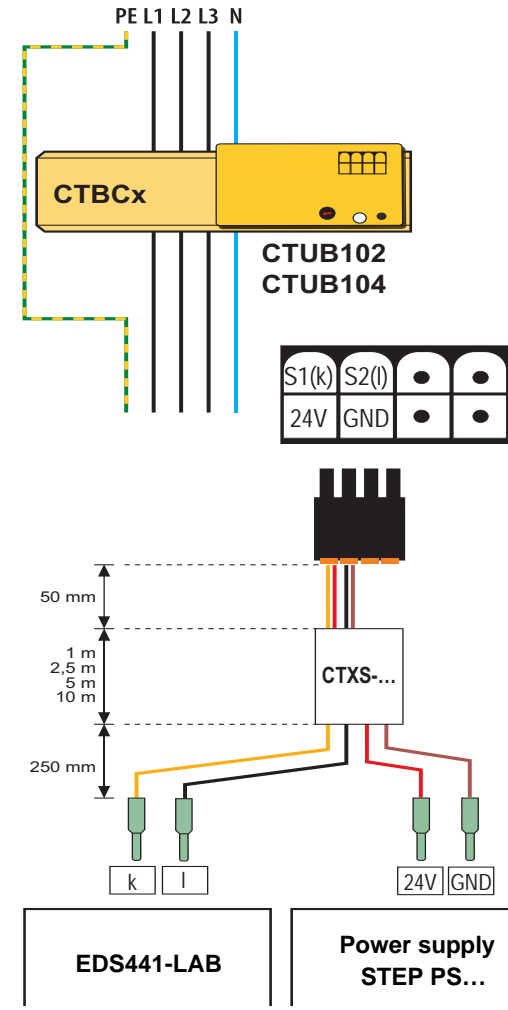

#### Locating current

**X** The EDS441-LAB-4 operates exclusively with a locating current of max. 5 mA. Therefore, selecting the current range > 500 mA on the current transformer is not suitable for measuring locating currents < 5 mA.

### 5.10.3 Connection of CTAF...SET series measuring current transformers to EDS440-LAF-4

For insulation fault location, the measuring current transformers of the CTAF...SET series are used.

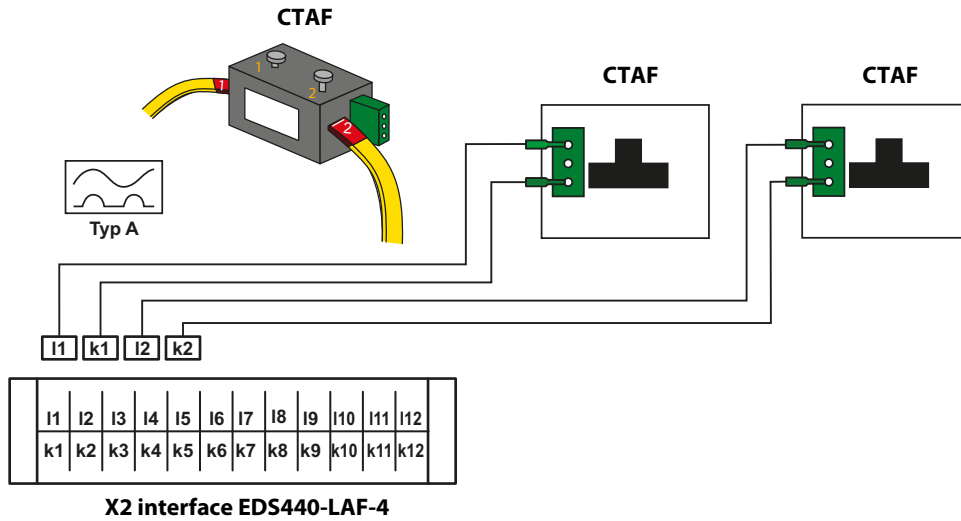

#### **Locating current**

*The EDS440-LAF-4 operates exclusively with a locating current > 10 mA.*

### 5.11 Wiring diagram to DC system with ISOMETER® iso685-D-P

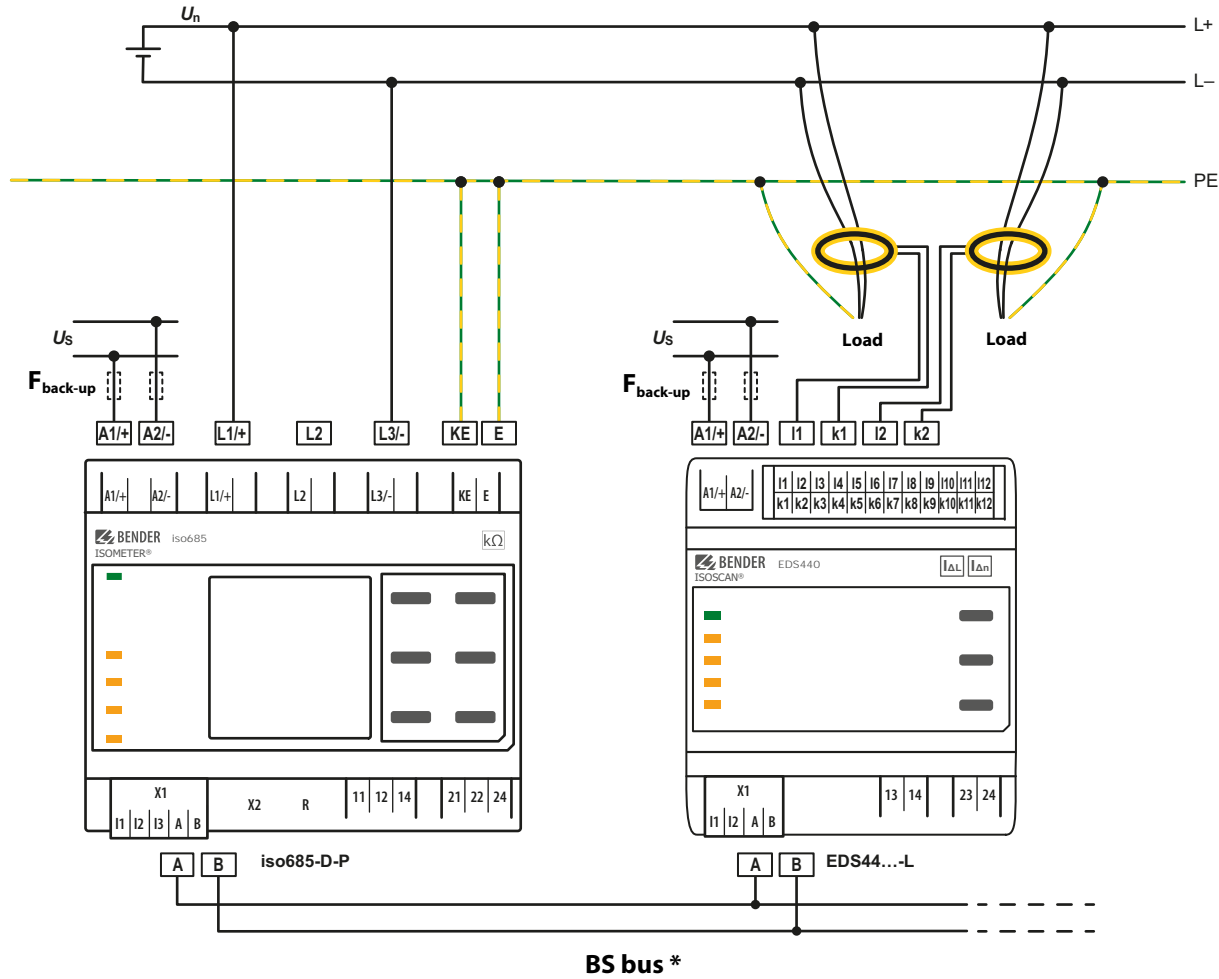

\* Communication between iso685-x-P and EDS44x-L only via BS bus (RS-485).

### 5.12 Wiring diagram to AC system with ISOMETER® iso685-D-P

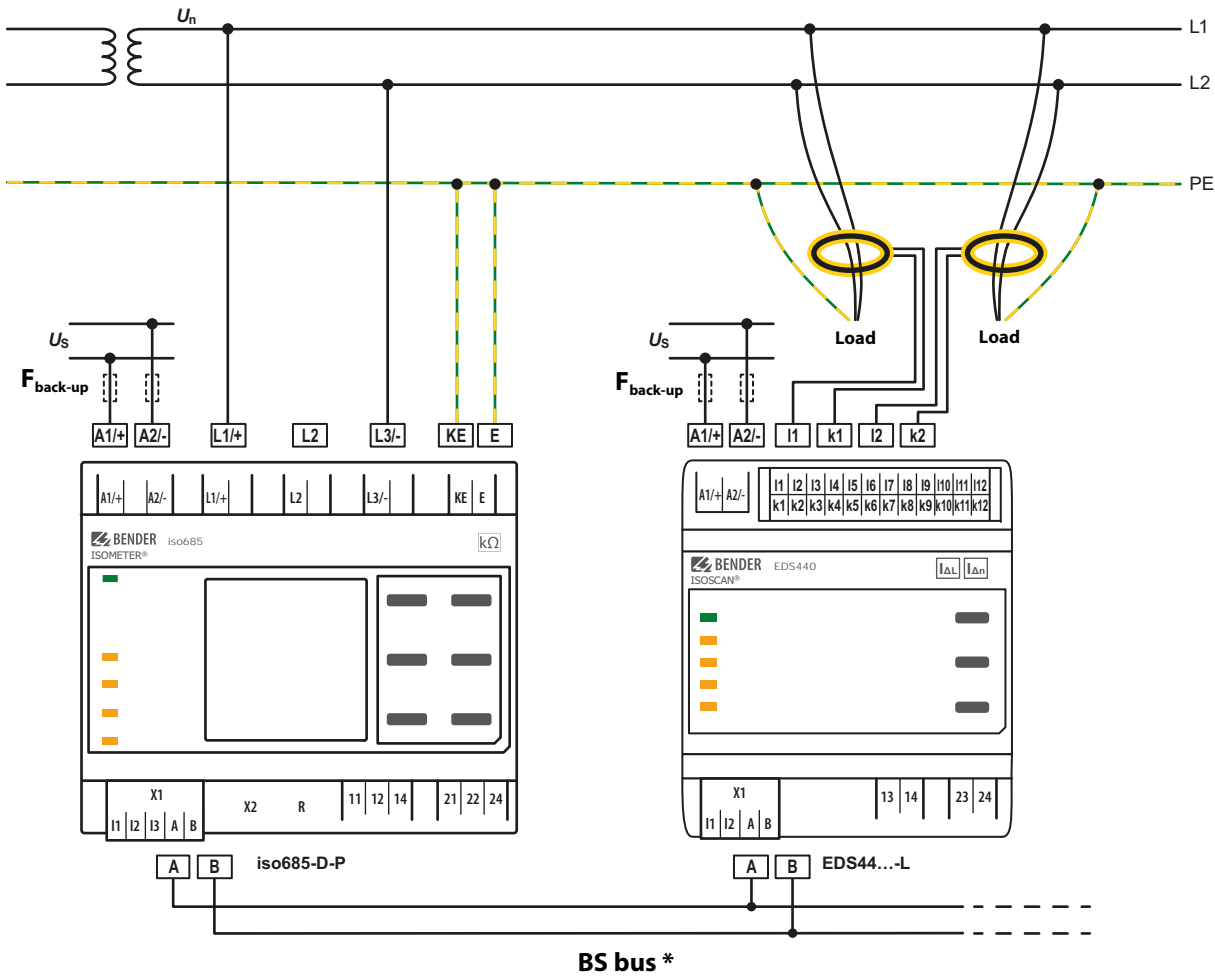

For systems > 690 V and with overvoltage category III a fuse for the connection to the system to be monitored must be provided. Recommendation: 2A fuses. \* Communication between iso685-x-P and EDS44x-L only via BS bus (RS-485).

### 5.13 Wiring diagram to 3(N)AC system with ISOMETER® iso685-D-P

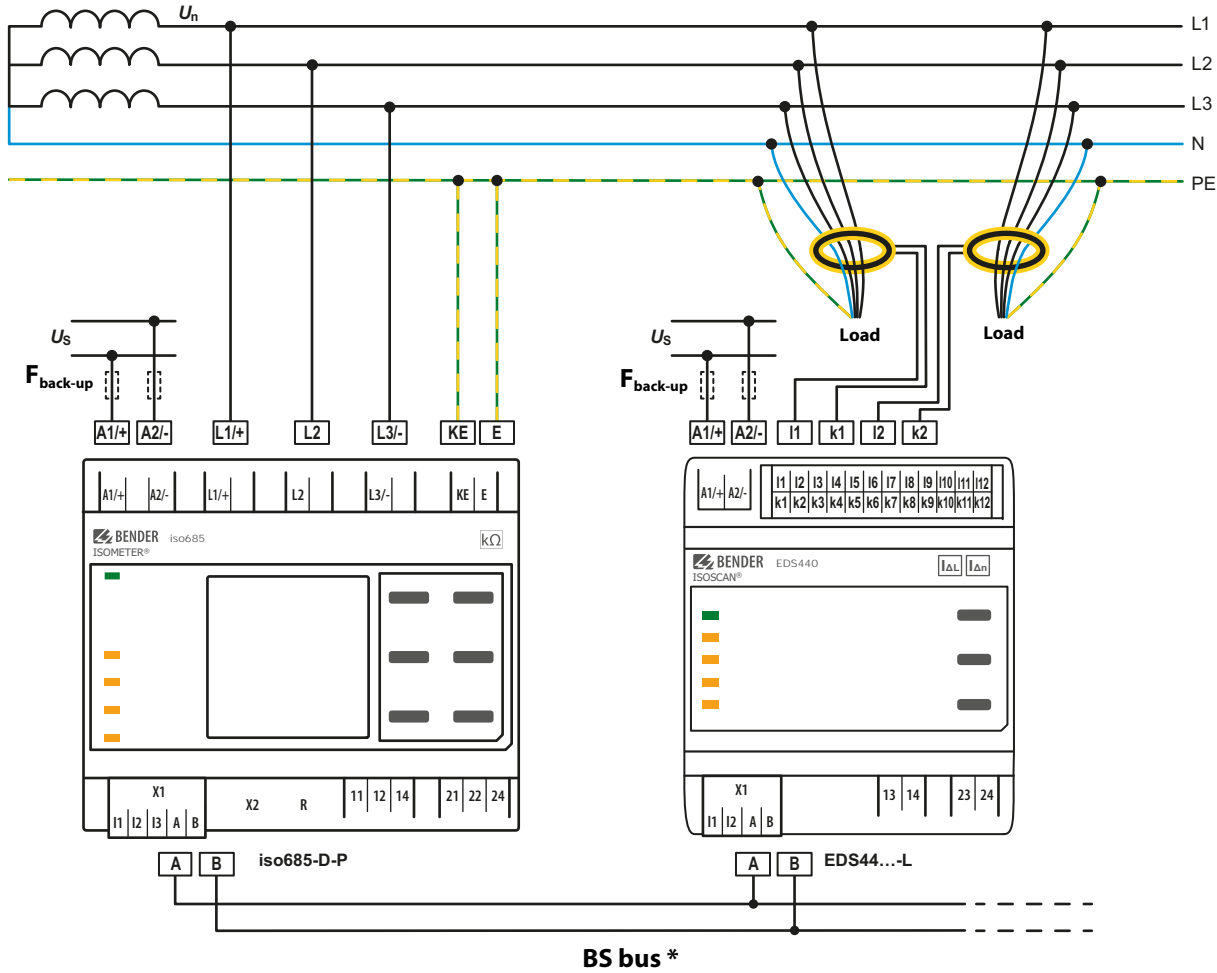

\* Communication between iso685-x-P and EDS44x-L only via BS bus (RS-485).

### 5.14 Connection example: ISOMETER® iso685-D-P, EDS440-S, IOM441-S and EDS440-L

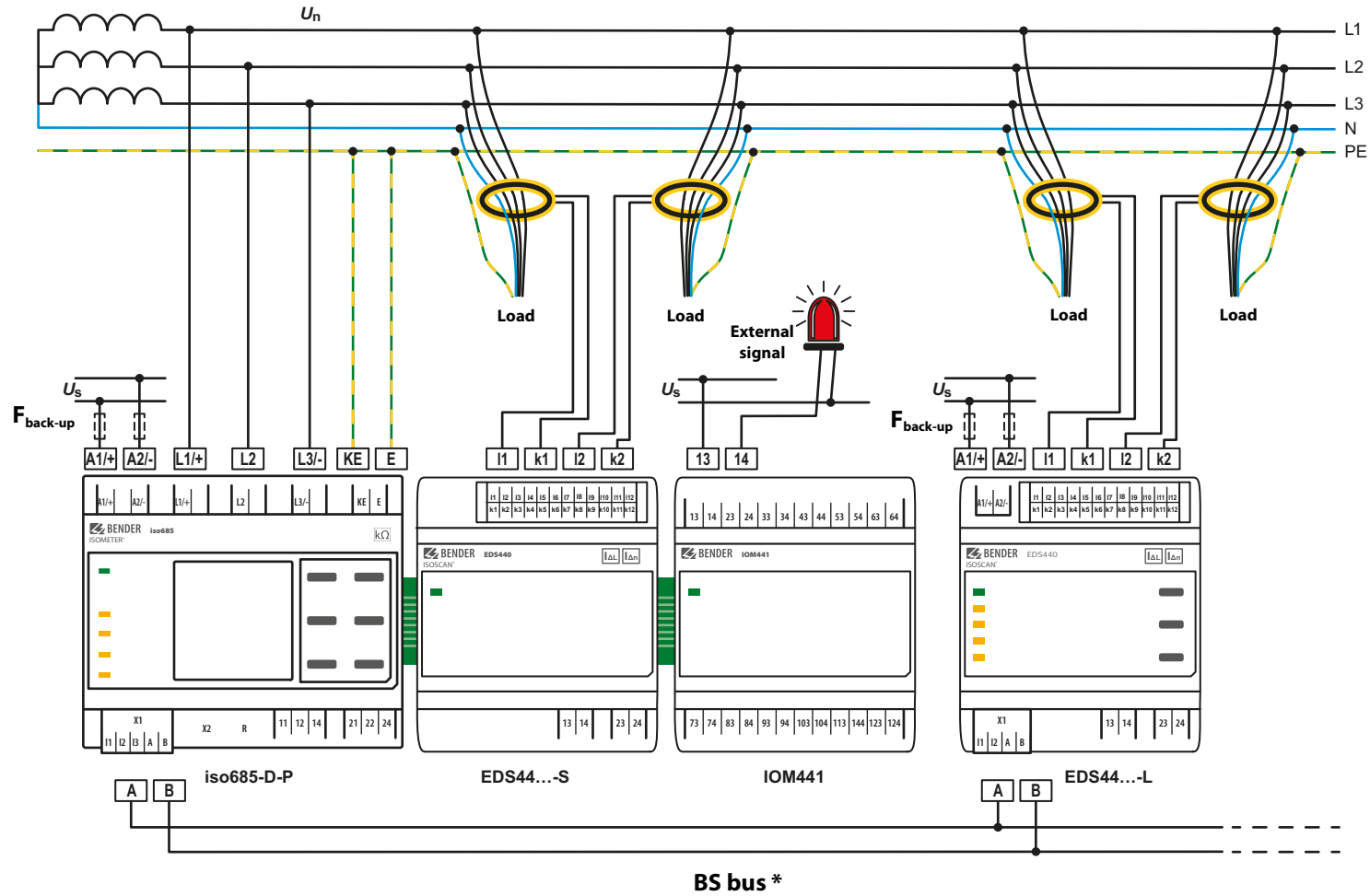

\* Communication between iso685-x-P and EDS44x-L only via BS bus (RS-485).

### 6.1 Operating and display elements EDS44x-S



- 1 The "ON" LED flashes until the device is ready for operation during power up. The "ON" LED lights up when the device is turned on. A current transformer connection test is carried out every hour. During the test, the "ON" LED flashes.
- 2 The "COM/ADDR." LED flashes quickly while the device communicates via the RS-485 interface. During insulation fault location, the LED flashes to indicate that the locating current injector is sending out a pulse: During the pulse phase, the LED is lit; during the pause, it is not lit. In the LAB procedure, the pulse can last up to one minute. Therefore, no constant "flashing" of the COM LED can be seen. The LED lights up continuously for the pulse time of up to 1 minute.

### 6.2 Operating and display elements EDS44x-L

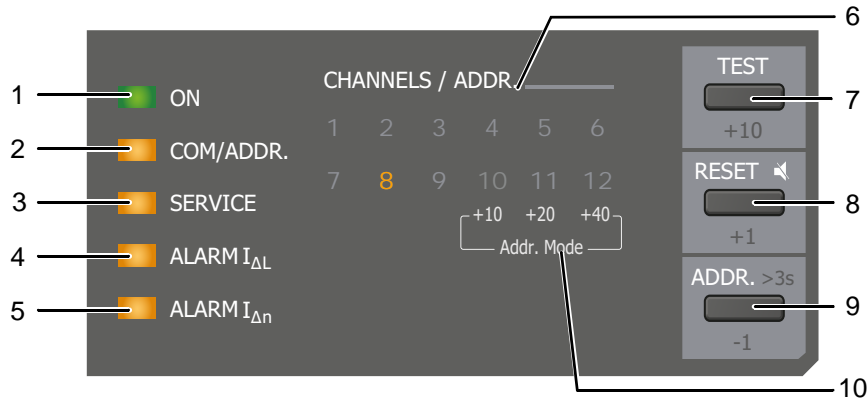

- 3 The "SERVICE" LED lights up either when there is a device error, a connection fault of the measuring current transformers or an error message e.g. due to low-frequency residual currents, external magnetic fields, etc.
- 4 The "ALARM  $I_{\Delta L}$ " LED signals the main alarm. The LED lights when an insulation fault is detected (EDS function) on one of the measuring channels.
- 5 The "ALARM  $I_{\Delta n}$ " LED lights up if the set response value for residual currents is exceeded. The factory setting for the response value is 10 A for the EDS440 and 1 A for the EDS441.
- 6 The channel LEDs "1"..."12" light up: A channel LED lights up if an insulation fault is detected on the respective measuring channel or if there is a residual current alarm. The channel LEDs "1"..."12" flash: If there is a connection fault of the measuring current transformer, the channel LED flashes slowly (1 Hz). If there is an interference during insulation fault location, the channel LED flashes quickly (2 Hz).
- 7 Pressing the TEST button triggers the self test of the device. In the address assignment mode, the address can be set in steps of ten. (+10)
- 8 You can reset the fault memory using the RESET button. The fault memory can only be reset if it is activated and the fault has been eliminated. In the address assignment mode, the address can be set in steps of one. (+1)
- 9 Pressing the button for 3 seconds activates the address assignment mode. In the address assignment mode, the address can be set in steps of one (+1 and -1) and steps of ten (+10).
- 10 Addr. Mode: Indication of the present tens counter by means of the channel LEDs 10, 11 and 12.



### 6.3 Standard display in the operating mode

The values of the EDS44x-L are mainly displayed via the connected ISOMETER® and the values of the EDS44x-S are only displayed via the connected ISOMETER®.

#### 6.3.1 Standard display EDS44x-S

In the operating mode, the EDS44x waits for the insulation fault location to start. The green operation LED "ON" lights up. All messages are indicated via the connected ISOMETER®.

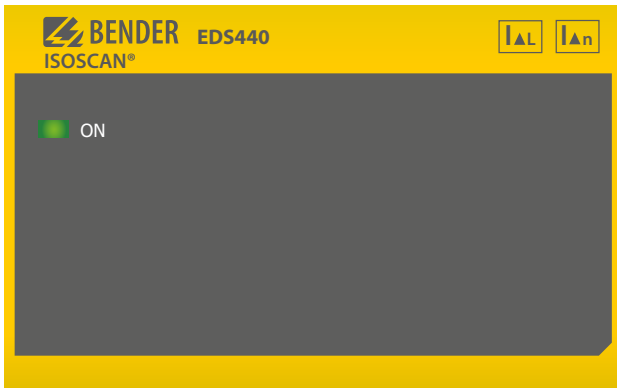

#### 6.3.2 Standard display EDS44x-L

In the operating mode, the EDS44x waits for the insulation fault location to start. There is no alarm on any of the 12 channels. The EDS44x-L displays its slave address on demand. Only the green operation LED "ON" lights up. While the device communicates or the insulation fault location is in progress, the "COM" LED flashes additionally.

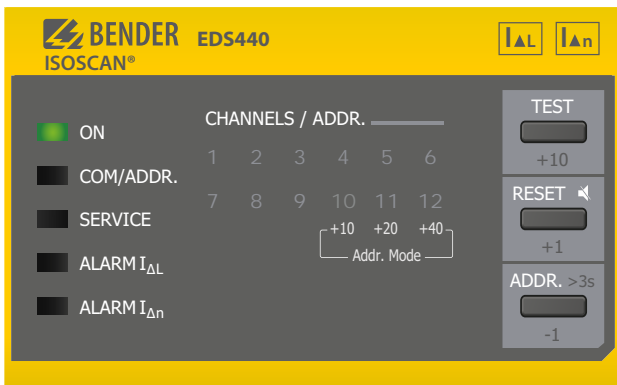

### 6.4 Alarm messages

Alarm messages of the EDS44x-L are directly indicated on the control panel of the device, while the alarm messages of the EDS44x-S are displayed on the respective ISOMETER®.

Possible causes of an alarm message are:

- Insulation faults, residual current exceeded, device errors, measuring current transformer faults or measuring current transformer connection faults and an interference.

#### 6.4.1 Insulation fault (ALARM I<sub>ΔL</sub>)

If an insulation fault is detected on a measuring channel, (EDS function), the "ALARM I<sub>ΔL</sub>" LED (main alarm) and the LED of the channel on which the fault was detected, lights up.

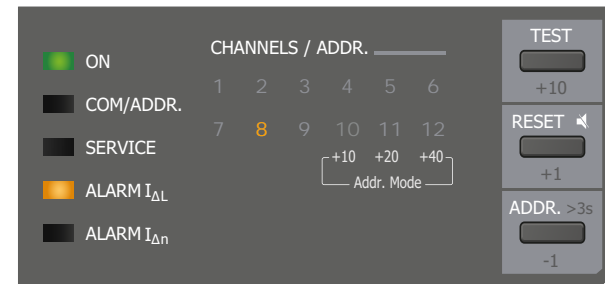

In addition, the fault is indicated on the display of the ISOMETER®.

#### 6.4.2 Residual current exceeded (ALARM I<sub>Δn</sub>)



*This function of the EDS441x is only suitable for frequencies in the 50/60 Hz range.*

The residual current flowing through the measuring current transformer is continuously measured and displayed. If the residual current is too high, a successful insulation fault location is not possible.

If the residual current (RCM function) is exceeded, the "ALARM I<sub>Δn</sub>" LED lights up. In addition, the LED of the channel on which the fault was detected lights up. Furthermore, the

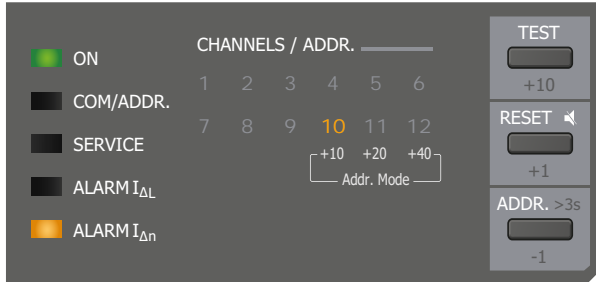

fault is indicated on the display of the ISOMETER®.

### 6.4.3 Connection fault of the current transformers

The "SERVICE" LED lights up if there is a connection fault of the CTs. In addition, the corresponding channel LED flashes.

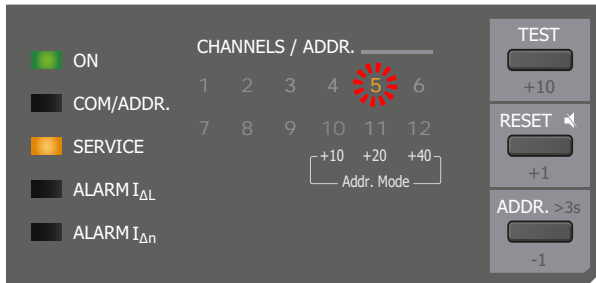

In the event of a device error, an error code is additionally displayed on the corresponding ISOMETER®. Please have it at hand for the Bender service.

### 6.4.4 Device error, BB bus error

The "SERVICE" LED and individual channel LEDs light up if there is a BB bus error.

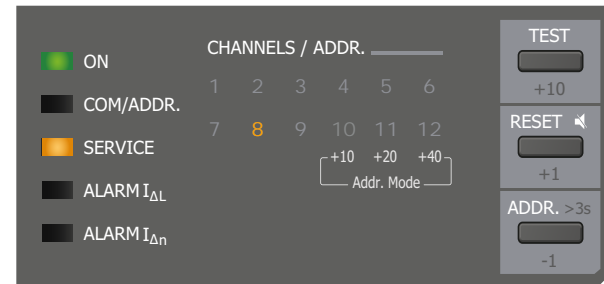

The following error code table shows the meaning of the displayed errors.

Error code BS bus channel 1	Meaning	Channel LED EDS44x-L
2.00	Faulty BB bus connection IOM441-5 (either connection IOM left OR more than one IOM)	2
6.32	No write protection boot loader/MFD	6
6.52	No flash lock	6
6.72	Incorrect measurement equipment HW	6
7.61	Error CAN auto address assignment	7
7.62	Necessary CAN bus device missing	7
7.63	Error CAN bus communication	7
8.42	Undervoltage/Overvoltage int. DC 24 V	8

### 6.4.5 Device error, failure BS bus master

Service and COM LED light up simultaneously and continuously.

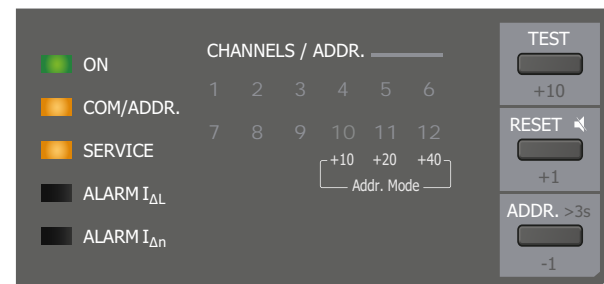

### 6.4.6 Error message

In the event of an error message, the LED of the respective channel flashes. An error can, for example, be caused by low-frequency residual currents, external magnetic fields, etc.

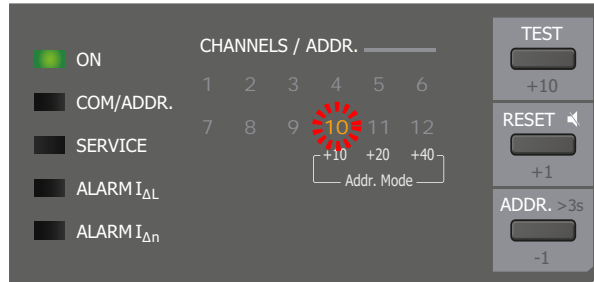

### 6.4.7 Acoustic alarm message

The acoustic alarm (buzzer) can be manually assigned to the following visual alarm messages:

- TEST
- Alarm  $I_{\Delta L}$ ; Alarm  $I_{\Delta n}$
- Connection fault; Device error
- Insulation fault location; Common alarm

The acoustic alarm can be deactivated by pressing the RESET button. For an overview of all alarm messages, refer to ["Alarm messages" on page 38](#).



CAUTION

### **Risk of overcurrent!**

Devices connected to the analogue output must have a suitable protective circuit against overcurrent to protect the device in the event of a defective analogue output.



Start the cyclic test of the EDS44x at regular intervals to ensure that the relays work and switch correctly. (e.g. once a year)

### 7.1 Before switching on

Before switching on the EDS44x, make sure that the following aspects have been considered:

- The connected supply voltage  $U_S$  matches the information on the nameplates of the devices.
- The maximum permissible nominal insulation voltage of the used measuring current transformers and the ISOMETER® with integrated locating current injector is not exceeded.
- The PE conductor is not routed through the measuring current transformer.
- Any magnetic fields that are nearby and could cause interference when mounting the measuring current transformers have been taken into account.
- Regarding the BS bus node address settings, no address has been assigned twice. The ISOMETER® with an integrated locating current injector (e.g. ISOMETER® iso685-D-P) has been set as master.

### 7.2 Switching on

1. Switch on the supply voltage of all devices connected to the BS bus or the BB bus. First, the "ON" LED flashes on the EDS44x. Subsequently, the "ON" LED lights up continuously.
2. Eliminate all displayed insulation faults and device errors via the ISOMETER®. If the response value is exceeded, the respective device error message is indicated on the EDS44x-L by the alarm LED "ALARM  $I_{\Delta L}$ " or "ALARM  $I_{\Delta n}$ ", which lights up (see "Alarm messages" on page 38).
  - Further information regarding fault messages on the EDS44x can be displayed via the ISOMETER®.
  - Device errors may be caused by measuring current transformers not being connected. Check the measuring current transformer connections. Disconnect the channels that are not required in the menu of the ISOMETER®.



Pending alarm messages may temporarily not be available due to synchronisation processes on the BS bus. However, if the cause of the alarm persists, the alarm messages reappear after a few seconds.

## 7.3 Steps for commissioning ISOMETER® and EDS44x

### Commissioning scheme - Steps for commissioning

	ISOMETER® commissioning	EDS44x commissioning	ISOMETER® with EDS44x commissioning
1	Connect device according to wiring diagram and device documentation	Connect device and measuring current transformer according to wiring diagram and device documentation	Switch off supply voltage of all devices
2	Switch on supply voltage	Switch on supply voltage	Connection of EDS to ISOMETER® * EDS44x-L: via BS bus * EDS44x-S: via BB bus
3	Switch on mains voltage	The <b>ON</b> LED flashes during power up until the device is ready for operation .	Switch on supply voltage of all devices.
4	Run commissioning wizard.	Set BS address on the rotary switches of the EDS44x-L. Display by channel LEDs	Set EDS mode in the ISOMETER® menu <b>EDS -&gt; General-&gt; Mode</b>
5	Self test of the ISOMETER®	Eliminate all possible device faults according to the device documentation	Search for configurable measuring channels in the ISOMETER® menu <b>EDS -&gt; Scan channels</b>
6	Functional test with suitable resistance from system to earth, size: 50 % of the alarm 2 response value	The EDS44x is fully functional and correctly connected.	Activate measuring channels in the ISOMETER® menu <b>EDS -&gt; Activate channel</b>
7	Remove resistance	CT connection test is carried out every 60 minutes. Indication by means of flashing <b>ON</b> LED	Set max. locating current in the ISOMETER® menu <b>EDS -&gt; General -&gt; Current</b> * EDS440x: 10...50 mA * EDS441x: 1...5 mA
8	Set "BS address = 1 Master" (corresponds to factory setting)		If necessary, make further settings for the EDS44x in the ISOMETER® menu <b>EDS</b>

	ISOMETER® commissioning	EDS44x commissioning	ISOMETER® with EDS44x commissioning
9	If necessary, adjust group settings		Functional test with suitable resistance from system to earth, size: 50 % of the alarm 2 response value
10	The ISOMETER® is fully functional and correctly connected.		Remove resistance
11			ISOMETER® and EDS44x are fully functional and correctly connected.

## 8. Device communication

### 8.1 BS bus

The BS bus is used to extend Bender measuring devices (e.g. ISOMETER®). It is an RS-485 interface with a specially developed protocol for Bender devices. On the BS bus, the transmission of alarm messages takes priority over the transmission of all other messages. For further information, refer to the BS bus manual (document number: D00278) at [www.bender.de/en/service-support/downloads](http://www.bender.de/en/service-support/downloads).



*When using interface converters, a galvanic separation is required.*



*The compatibility of the BS bus and the BMS bus is restricted!*

#### 8.1.1 Master-slave principle

The BS bus works according to the master-slave principle. This means that the measuring device operates as the MASTER, while all sensor devices operate as SLAVES. The master is responsible for the communication necessary for the measuring function. It also provides the required bus bias voltage for the operation of the BS bus.

#### 8.1.2 Addresses and address ranges on the BS bus

Address 1 is assigned to the master device. All sensor devices receive unique addresses starting with address 2, assigned in consecutive order without gaps. Sensor devices are only queried up to address 99.

#### 8.1.3 RS-485 specifications/cables

The RS-485 specification restricts the cable length to 1200 m and requires a daisy chain connection. The number of devices on the BS bus is only limited by the BS bus master.

Use twisted pair, shielded cables for bus cabling. For example, cable type J-Y(St)Y n x 2 x 0.8 is suitable. The shield must have a single-ended connection to earth. The BS bus must be terminated at both ends with terminating resistors (120 Ω, 0.25 W). The terminating resistors are connected in parallel to the terminals A and B. Some devices feature integrated terminating resistors and can be activated or deactivated via the "R" button.

#### 8.1.4 Cable routing

The optimum cable routing for the BS bus is a double-terminated bus topology. The length of the branch line is limited to 1 m. These branch lines do not have to be terminated.

Bus topology examples:

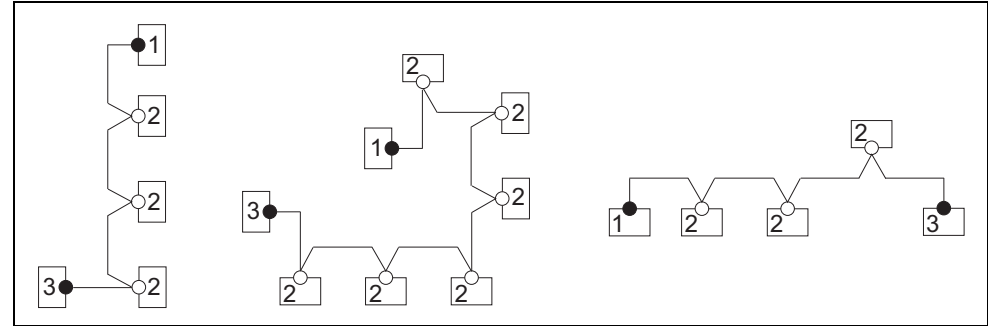

#### Termination

- |   |        |   |
|---|--------|---|
| 1 | Master | Terminating resistor activated via switch on device (ON) or external terminating resistor between terminals A and B |
| 2 | Slave  | Terminating resistor deactivated via switch on device (OFF)   |
| 3 | Slave  | Terminating resistor activated via switch on device (ON) or external terminating resistor between terminals A and B |



*Only the first and last device may be terminated. Therefore, check all devices.*

### 8.2 Modbus RTU

Modbus RTU is implemented on the RS-485 interface. The data transmission is binary/serial. Error-free and continuous data transmission must be guaranteed.

Measured values, messages and parameters are stored in virtual register addresses. Data can be read out with a read command on the register address. With a write command, data can be written into a register address. The register addresses of the individual measured values and parameters can be found in the "iso685-D Annex A" manual with the title "ISOMETER® iso685 device family - Modbus settings" at [www.bender.de/en/service-support/downloads](http://www.bender.de/en/service-support/downloads).

# 9. Operation

## 9.1 Reading out and setting the BS address



If the BS address is set to 0, the device goes into the trigger mode "auto". See "Trigger function" on page 34.

### 9.1.1 Reading out a BS address

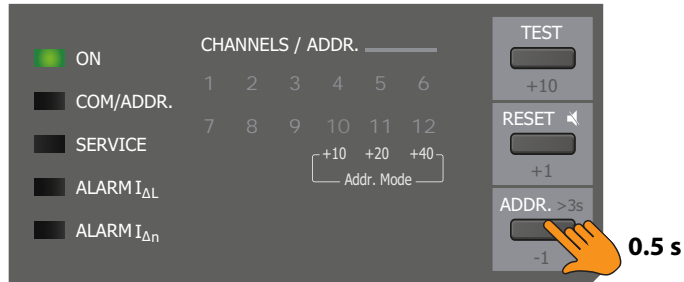

Address: 2



The current address is displayed with the "COM/ADDR." LED lit and the channel LED for 4 seconds. If the device is in an extended address range (80...158), the address is displayed with the "COM/ADDR." LED flashing and the channel LED.

Address: 82



(see "Chapter 9.1.3 Extended address range (offset = 80)" )

### 9.1.2 Setting a BS address

Activate address input



Address input is active

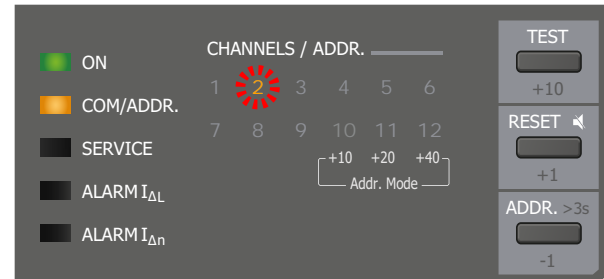

Enter target value

Example: Addr. 27

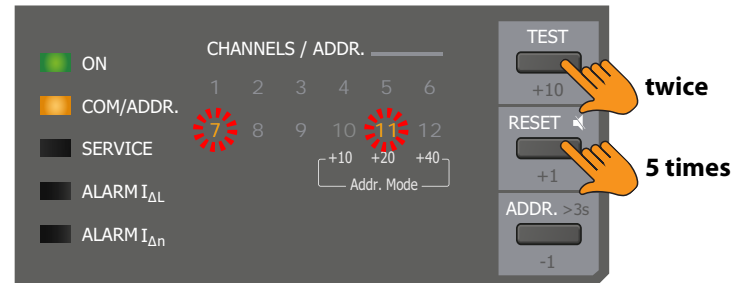

Exit address input

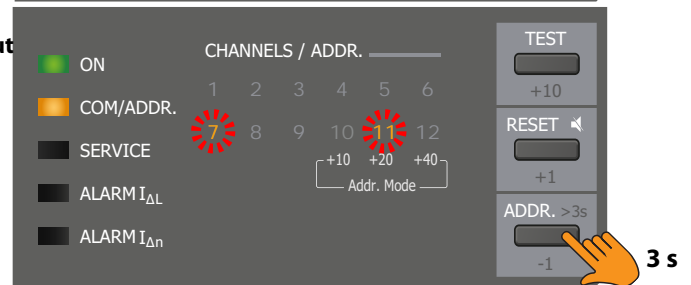

For addresses where the unit value is "0" (0, 10, 20, ...), the LEDs of the unit values do not flash.

### 9.1.3 Extended address range (offset = 80)

**Activate address input**

**Change address range**

**Example: offset = 80 + addr. 27 = addr. 107**

**Exit address input**

For addresses where the unit value is "0" (0, 10, 20, ...), the LEDs of the unit values do not flash.

## 9.2 Display and change of transmission protocols

### 9.2.1 Displaying the current transmission protocol

LED sequence BS bus	LED sequence Modbus
COM/ADDR.	ALARM I <sub>Δn</sub>
SERVICE	ALARM I <sub>ΔL</sub>
ALARM I <sub>ΔL</sub>	SERVICE
ALARM I <sub>Δn</sub>	COM/ADDR.

Each sequence is repeated 3 times.

### 9.2.2 Changing the transmission protocol

The LEDs on the left flash twice in the order of the currently set transmission protocol (e.g. from top to bottom for the BS bus protocol) and then change the direction (e.g. from bottom to top for the Modbus RTU protocol). They flash twice in the order of the newly selected protocol and then switch to the operating mode.



### 9.3 Resetting saved alarm messages (RESET button)

If the fault memory is enabled, the alarm state will remain, even after the cause of the fault has been eliminated, until a "RESET" is carried out.

A RESET is carried out in the following way:

- Press the "RESET" button on the front panel of the EDS44x-L twice (EDS44x-L only)
- Press an external RESET button connected to the EDS44x-x
- Send a RESET command via the BS bus (EDS44x-x)

Saved alarm messages that are no longer pending are deleted, the alarm relay is de-energised, the alarm LEDs go out and no alarm messages remain on the BS bus.

### 9.4 Deactivating the buzzer and resetting the fault message

- Press the RESET button on the EDS44x-L to mute the buzzer for the present alarm message.
- To reset a fault message, press the RESET button again.

The buzzer functions can be assigned in the device menu of the ISOMETER®. For further information, refer to ["Digital outputs of the EDS44x-L" on page 36](#) or to the manual of the ISOMETER®.

### 9.5 Running a test (TEST button)

A test can be carried out to check the device function of the EDS. There are several ways to start a test:

EDS44x-L:

- Select standard display on the ISOMETER® and then press the "TEST" button on the front panel of the EDS44x-L.
- Press an external TEST button connected to the digital input
- Send TEST command via BS bus or Modbus RTU.

EDS44x-L and ...-S:

- Press TEST button on the ISOMETER®.

The EDS44x-L responds as follows:

- "ALARM I<sub>ΔL</sub>" LED and "ALARM I<sub>Δn</sub>" LED light up.
- All alarm relays switch (function can be deactivated).
- An alarm message is sent on the BS bus.
- An entry with the suffix "TEST" is stored in the history memory of the ISOMETER®.
- All active channel LEDs light up.

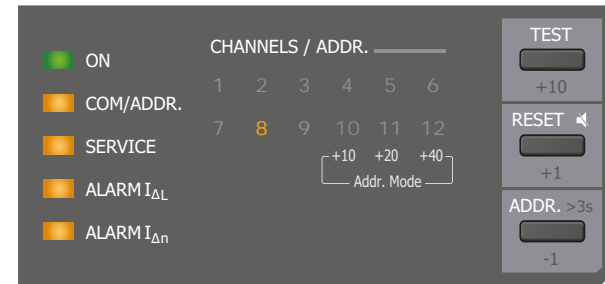

After finishing the test, all LEDs must go out again, except the "ON" LED.

## 10.1 EDS settings on the ISOMETER®

Settings of the EDS44x are made via the device menu of the ISOMETER®. For a detailed menu description, refer to the manual of the ISOMETER®.

### 10.1.1 Locating current injector settings

#### 10.1.1.1 Mode

Three different start and stop conditions for insulation fault location can be set on the ISOMETER®:

- **Manual** The EDS system can be started manually using a shortcut button or via the menu. Afterwards, the EDS system is permanently active, regardless of the insulation value and the alarm message of the ISOMETER®. The EDS system can be stopped manually at any time using the shortcut button or via the menu.
- **auto** The EDS system is activated automatically as soon as the response values of alarm 1 and alarm 2 of the ISOMETER® fall below the limit. It remains active until no more insulation faults are detected. For new measurement of the insulation fault values by the ISOMETER®, the EDS insulation fault location is cyclically interrupted for approx. 5 minutes. The EDS system can be stopped manually at any time using the shortcut button or via the menu.
- **1 cycle** The EDS system is automatically activated for 5 minutes as soon as the response values of alarm 1 and alarm 2 of the ISOMETER® fall below the limit. After this cycle, the insulation fault location is completed. The EDS system can be stopped manually at any time using the shortcut button or via the menu.



#### **Insulation monitoring**

*During the insulation fault location process, insulation monitoring is temporarily inactive.*

*During the insulation fault location process, connection and short-circuit monitoring is temporarily inactive.*

### 10.1.1.2 Locating current

You can set the maximum locating current of the locating current injector in the ISOMETER®.

- For the EDS441-x, a locating current of 1 mA...5 mA is suitable.
- For the EDS440-x, a locating current of 10 mA...50 mA is suitable.

- 1 mA for EDS441-x
- 1.8 mA for EDS441-x
- 2.5 mA for EDS441-x
- 5 mA for EDS441-x/EDS440-x
- 10 mA for EDS440-x
- 25 mA for EDS440-x/EDS440-LAF-4
- 50 mA for EDS440-x/EDS440-LAF-4



*A combination of a high current transformer inductance, a high residual current outside the specified frequency range and simultaneously a high locating current can lead to saturation effects in the current transformer and thus influence the measurement. It is recommended to work with a locating current of max. 10 mA (EDS440). If the locating current is distributed among several parallel faults, it can be increased.*

### 10.1.2 Trigger function

The locating current pulse of the ISOMETER® is synchronised with the measurement technology in the EDS44x. The EDS44x is informed when to expect a locating current pulse. This allows a more reliable detection of the locating current pulse in the event of disturbances. Disturbances can be caused e.g. by variable-speed drives, rectifiers, actuators, noise filters, PLCs, or control electronics.

- **Com** Synchronisation via BS bus. The EDS44x only searches for insulation faults if the insulation fault location has been started. It knows the time of the locating current pulse. Less time is needed for the insulation fault location as with the setting "auto".
- **auto** No synchronisation (e.g. if there is no BS bus or Modbus RTU). The EDS44x continuously searches for insulation faults. If the BS address is set to 00, the device goes into the trigger mode "auto".

### 10.1.3 Fault memory

Faults that only occur temporarily can be saved in the ISOMETER®.

- on After eliminating the cause of fault, alarm messages remain stored until a RESET is carried out. This function affects alarm messages. Device error messages cannot be deleted.
- off The EDS44x exits the alarm mode as soon as the cause of fault has been eliminated.

## 10.2 Settings of inputs and outputs of the EDS44x-L

The settings of the EDS44x are done via the device menu of the ISOMETER®. For a detailed menu description, refer to the manual of the ISOMETER®.

### 10.2.1 Digital inputs of the EDS44x-L (I1, I2)

The EDS44x-L features two digital inputs (I1 and I2 on the X1 plug), which can be individually configured.

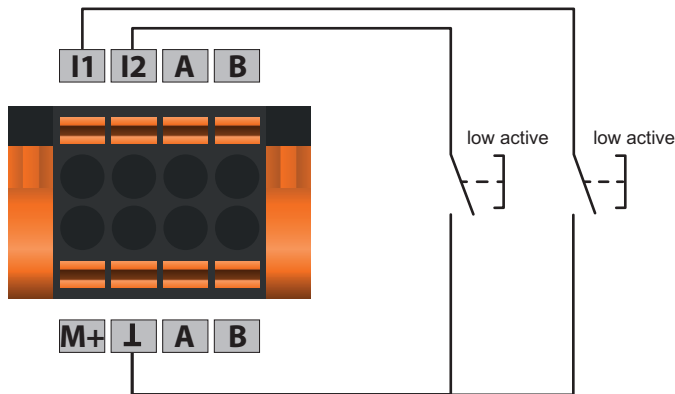

#### 10.2.1.1 Functions

You can assign the following functions for the digital inputs:

- off Digital input without function.
- TEST Device self test.
- RESET Reset of fault and alarm messages.

### 10.2.1.2 Digital input mode

The operating mode for the digital input can be set to the following values:

#### \*Active high



An event is carried out on the rising edge of the digital input (low to high).

Response time  $t(\text{on})/t(\text{off})$  after a switch-on signal.

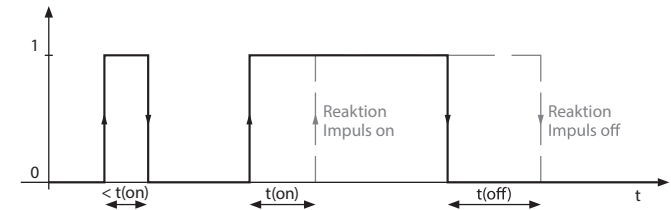

#### \*Active low

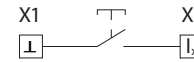

An event is carried out on the falling edge of the digital input (high to low).

Response time  $t(\text{on})/t(\text{off})$  after a switch-off signal.

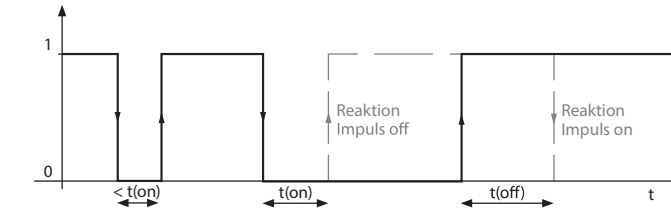

### 10.2.1.3 Response times $t(\text{on})/t(\text{off})$

- on The response time  $t(\text{on})$  after a switch-on signal can be set between 100 milliseconds and 300 seconds (5 min.).
- off The response time  $t(\text{off})$  after a switch-off signal can be set between 100 milliseconds and 300 seconds (5 min.).

## 10.2.2 Digital outputs of the EDS44x-L

The EDS44x-L features a digital current output (0 or 20 mA), a buzzer and relays, which can be configured individually.

### 10.2.2.1 TEST function

The function test checks the switching functions of the digital outputs. This only applies to the manual test and not to the cyclic device self test.

### 10.2.2.2 Operating mode of the relays

The relay mode can be adapted to the application:

- N/C Normally closed - N/C operation contacts 13-14 / 23-24 (The alarm relay is energised in normal operation).
- N/O Normally opened - N/O operation contacts 13-14 / 23-24 (The alarm relay is de-energised in normal operation).

### 10.2.2.3 Digital current output (M+)

Connection example of the digital output

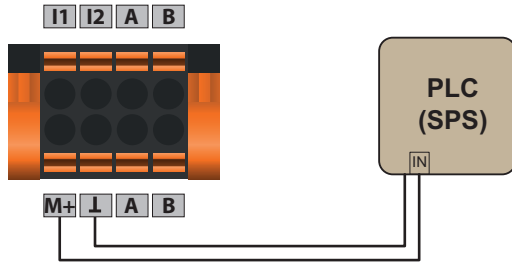

The digital current output is located at M+ of the X1 plug.

If a function is assigned and active, the digital current output carries 20 mA. Otherwise no current (0 mA) is carried.

## 10.2.2.4 Functional description

Up to three functions can be assigned to one output. The functions are linked to an OR operator:

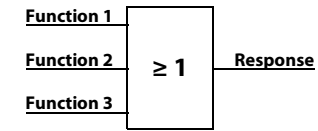

The following output functions are possible:

- off The function is not used.
- $I_{\Delta L}$  The status of the output changes if an insulation fault is detected (EDS function) on one of the measuring channels.
- $I_{\Delta N}$  The status of the output changes if the residual current (RCM function) is exceeded.
- Device error The status of the output changes in the event of an internal device error.
- Connection fault The status of the output changes when one of the following measuring current transformer connection faults occurs:
  - Measuring current transformers defective
  - Power supply cable interrupted
  - Power supply cable short-circuited
- Common alarm The status of the output changes on the occurrence of any alarms and fault messages ( $I_{\Delta L}$  alarm,  $I_{\Delta N}$  alarm, connection and device error).
- Insulation fault location active (for buzzer only) The buzzer signals active insulation fault location.
- BS bus malfunction (not for buzzer) Message in case of a faulty BS bus connection
  - No master available
  - A/B interchanged
  - A/B short-circuited
  - A/B separated

## 10.3 Factory settings

Parameter	Value
<b>General information</b>	
Response value insulation fault location ( $I_{\Delta L}$ )	0.5 mA (EDS441-x, EDS441-LAB) 5 mA (EDS440-x) 10 mA (EDS440-LAF)
Response value residual current measurement ( $I_{\Delta n}$ )	10 A (EDS440-x) 1 A (EDS441-x, EDS441-LAB)
Measuring current transformer type	Type A: EDS440-x, EDS441-x, EDS440-LAF Type AB: EDS441-LAB
Connection monitoring	on (inactive for W...AB!)
Fault memory	off
Trigger mode	com
Bus type	BS bus
Bus address	2
<b>Relays</b>	
Relay K1 test	on
Relay K1 operating mode	N/O
Relay K1 function 1	$I_{\Delta L}$ alarm
Relay K1 function 2	off
Relay K1 function 3	off
Relay K2 test	on
Relay K2 operating mode	N/O
Relay K2 function 1	$I_{\Delta n}$ alarm
Relay K2 function 2	off
Relay K2 function 3	off
<b>Channel relays 1 to 12 (optional extension with IOM441-S)</b>	
Channel relays K1...12 test	on
Channel relays K1...12 operating principle	N/O
Channel relays K1...12 function 1	$I_{\Delta L}$ alarm
Channel relays K1...12 function 2	$I_{\Delta n}$ alarm
Channel relays K1...12 function 3	off

Parameter	Value
<b>Buzzer</b>	
Buzzer test	on
Buzzer function 1	off
Buzzer function 1	off
Buzzer function 1	off
<b>Digital current output (M+)</b>	
Dig. Out test	off
Dig. Out function 1	off
Dig. Out function 2	off
Dig. Out function 3	off
<b>Digital inputs</b>	
Dig. In 1 mode	Active low
Dig. In 1 t(on)	100 ms
Dig. In 1 t(off)	100 ms
Dig. In 1 action	Test
Dig. In 2 mode	Active low
Dig. In 2 t(on)	100 ms
Dig. In 2 t(off)	100 ms
Dig. In 2 action	Reset

# 11. Alarm messages

Alarm message	Description	Measures	Reference
<ul style="list-style-type: none"> <li>• "ALARM I<sub>ΔL</sub>" LED lights up</li> <li>• Channel LED lights up</li> </ul>	The set response value of the insulation level has been exceeded on one channel.	<ul style="list-style-type: none"> <li>• Determine cause of the insulation fault and eliminate it.</li> </ul>	<a href="#">see "Insulation fault (ALARM I<sub>ΔL</sub>)" on page 25</a>
<ul style="list-style-type: none"> <li>• "ALARM I<sub>Δn</sub>" LED lights up</li> <li>• Channel LED lights up</li> </ul>	The set response value of the residual current has been exceeded on one channel.	<ul style="list-style-type: none"> <li>• Determine cause of the exceeded residual current and eliminate fault.</li> </ul>	<a href="#">see "Residual current exceeded (ALARM I<sub>Δn</sub>)" on page 25</a>
<ul style="list-style-type: none"> <li>• "SERVICE" LED lights up</li> </ul>	Internal device error	<ul style="list-style-type: none"> <li>• Press the TEST button</li> <li>• Switch the supply voltage off and on</li> <li>• Read out error code on the corresponding ISOMETER®</li> <li>• Contact Bender service</li> </ul>	<a href="#">see "Connection fault of the current transformers" on page 26</a>
<ul style="list-style-type: none"> <li>• "SERVICE" LED lights up</li> <li>• Channel LED flashes</li> </ul>	Connection fault of the current transformers Possible causes: <ul style="list-style-type: none"> <li>• Measuring current transformers defective</li> <li>• Power supply cable interrupted</li> <li>• Power supply cable short-circuited</li> </ul>	<ul style="list-style-type: none"> <li>• Replace defective measuring current transformers</li> <li>• Check cables</li> </ul>	<a href="#">see "Connection fault of the current transformers" on page 26</a>
<ul style="list-style-type: none"> <li>• Channel LED flashes</li> </ul>	Interferences during measurement Possible causes: <ul style="list-style-type: none"> <li>• Low-frequency residual currents</li> <li>• External magnetic fields</li> </ul>	<ul style="list-style-type: none"> <li>• Identify interference sources and eliminate them</li> </ul>	



*If several alarm messages appear at a time, the indication changes correspondingly. In this case, the alarm LED and the channel LED of the faulty channel light up together for approx. two seconds.*

## 12.1 Response sensitivity curves

System type, system voltage, system frequency, leakage capacitance and locating current influence the response sensitivity of the EDS system.



### Locating current

The locating current level can be set on the ISOMETER®. In AC systems, a reduced locating current occurs, conditioned by the system type. In contrast to DC systems, the factor in AC systems is 0.5 and in 3AC systems, 0.67.

Therefore, for use in AC and 3AC systems, set the response value on the EDS44x as follows:

Locating current	EDS	Response value
25 mA	EDS440-LAF	10 mA fixed
10 mA	EDS440	< 5 mA
1 mA	EDS441	< 0.5 mA



### Response values and characteristic curves

The response values are displayed as a characteristic curve, the maximum error can be ±50%. The tolerances of the measuring current transformers are included. The characteristic curves apply to the respectively indicated nominal voltage. In the event of nominal voltage deviation, you should calculate with a proportional modification of the response values. System voltages that change during operation or superimposed AC currents that differ from the system frequency (e.g. via frequency inverters) or from DC currents may result in response values beyond the indicated ranges.

The following characteristic curves allow easy determination of a practical response value for the insulation monitoring device and the EDS44x. Proceed as follows:

1. Select the characteristic curves (3AC, AC, DC) that match your system type.
2. From this group, select a diagram with a system voltage that comes closest to the desired system voltage.
3. Determine the expected leakage capacitance  $C_e$  of the monitored system in the ISOMETER®. Enter this value as a vertical line in the diagram.
4. The represented characteristic curves show the response sensitivity of the EDS system with a response value of 2 mA, 5 mA and 10 mA set on the EDS. Values above the respective curve cannot be recorded.
5. Select the middle characteristic curve for a response value of the EDS44x of 5 mA (factory setting EDS440). Mark the leakage capacitance  $C_e$  on the characteristic curve. Read out the corresponding resistance  $R_e$  on the characteristic curve. The determined resistance  $R_e$  indicates the maximum response value that may be set on the insulation monitoring device (e.g. ISOMETER® iso685-D-P). If higher response values are set, insulation faults are no longer reliably detected. A reliable response of the insulation monitoring device is a prerequisite for starting the EDS system.
6. If the insulation monitoring device is to be set to a higher or lower response value, determine the resistance R for the upper and lower characteristic curve as described in point 5. Values and characteristic curves in the range between the upper and lower characteristic curve can be roughly estimated using the existing characteristic curves.
7. Set the determined response values on the insulation monitoring device and on the EDS44x.

### 12.1.1 Characteristic curves EDS440 for 3AC systems

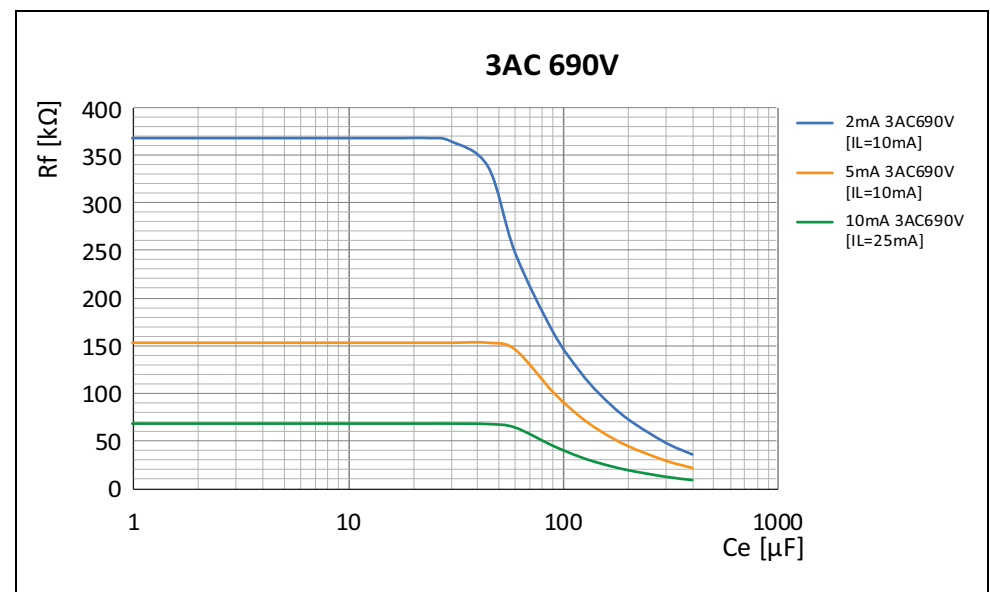
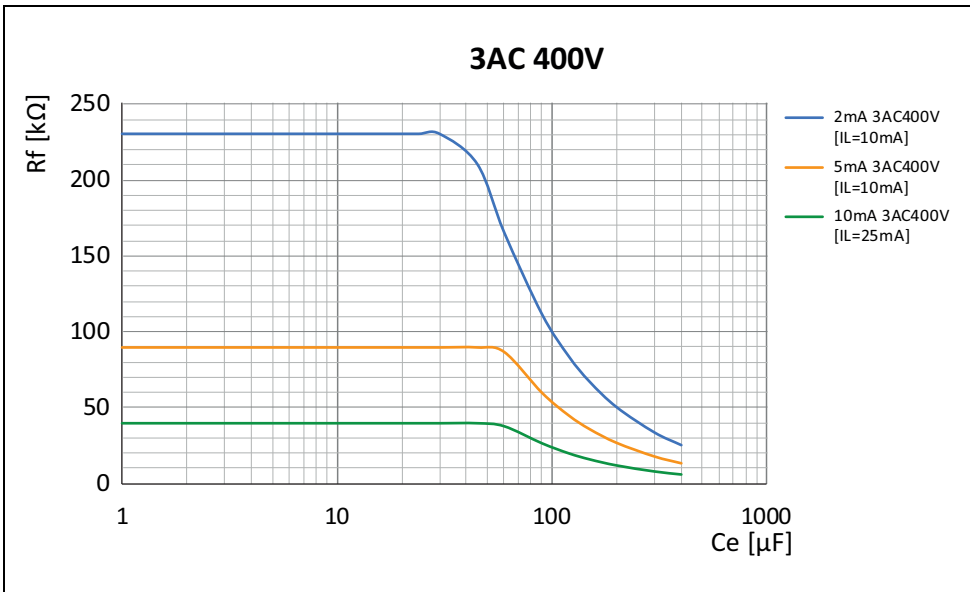
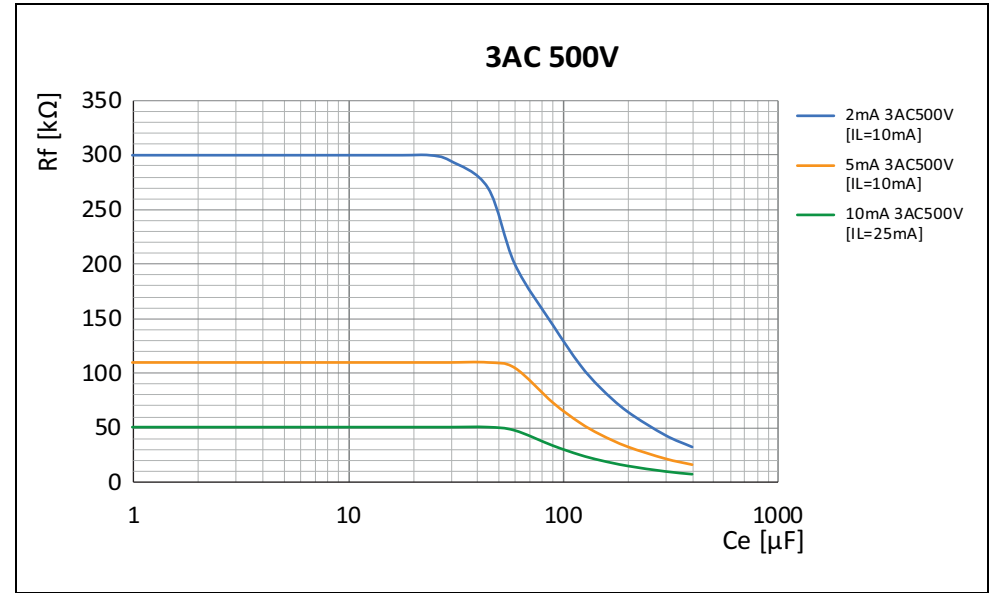
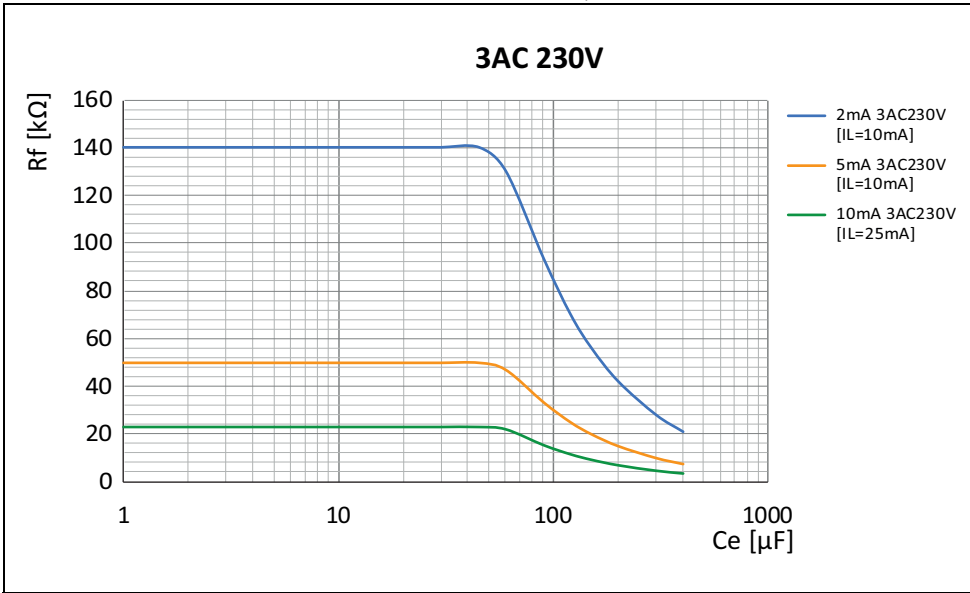



### 12.1.2 Characteristic curves EDS440 for AC systems

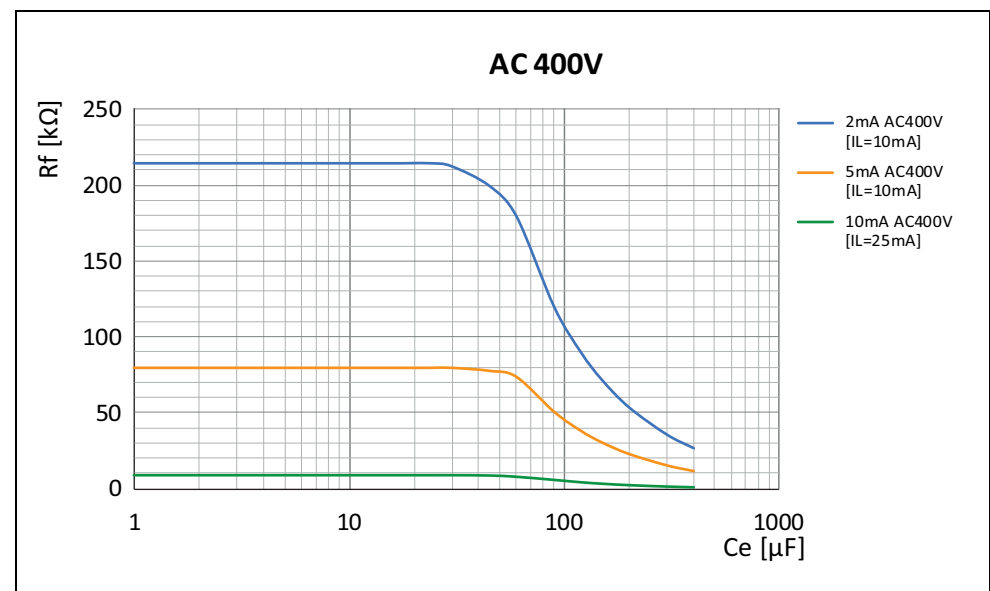
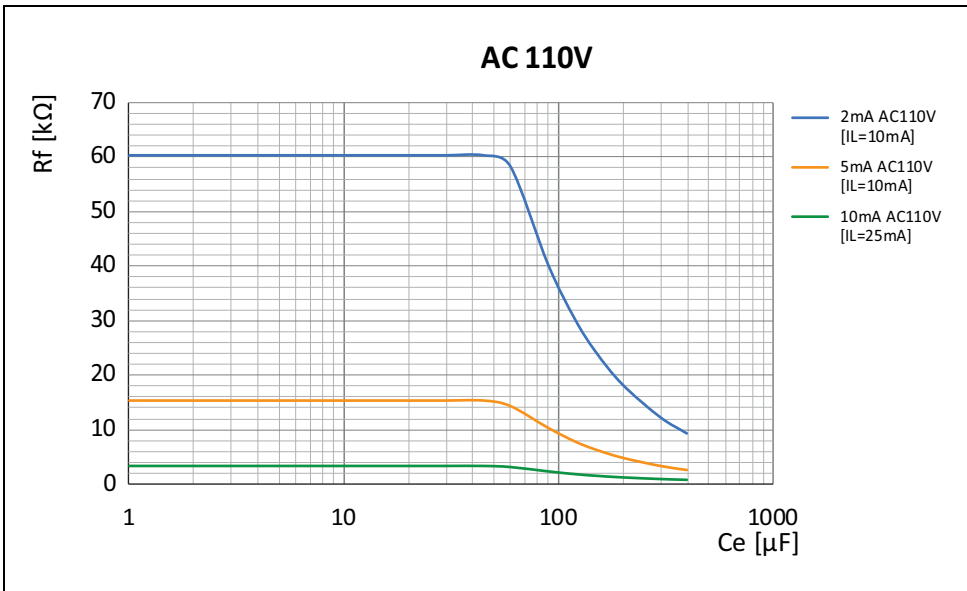
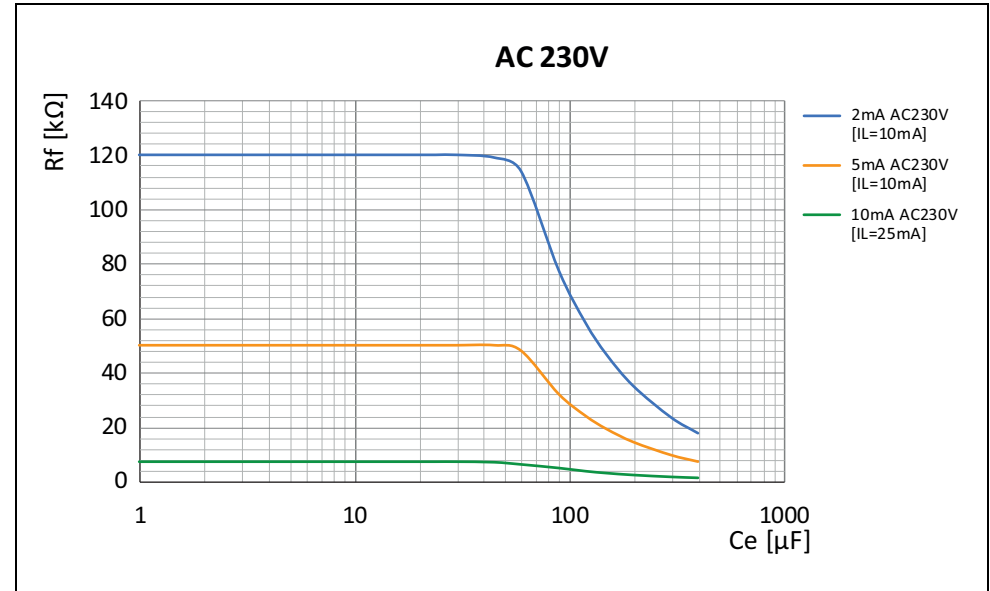
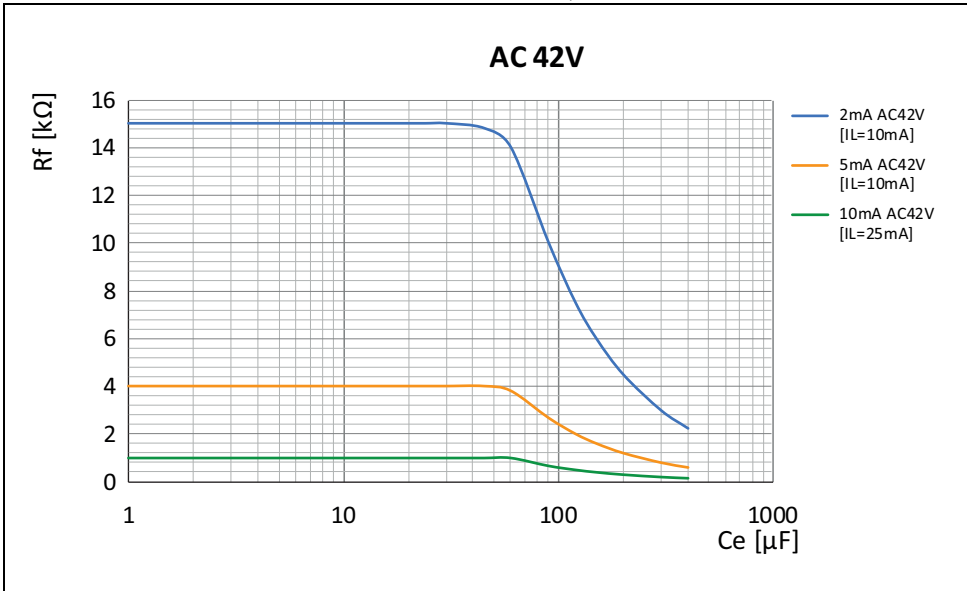

### 12.1.3 Characteristic curves EDS440 for DC systems

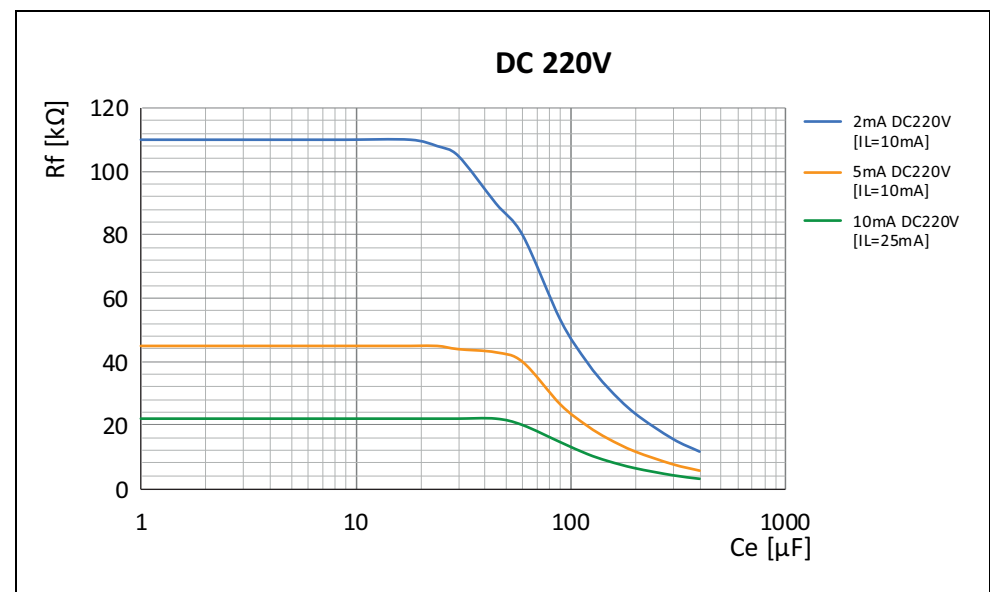
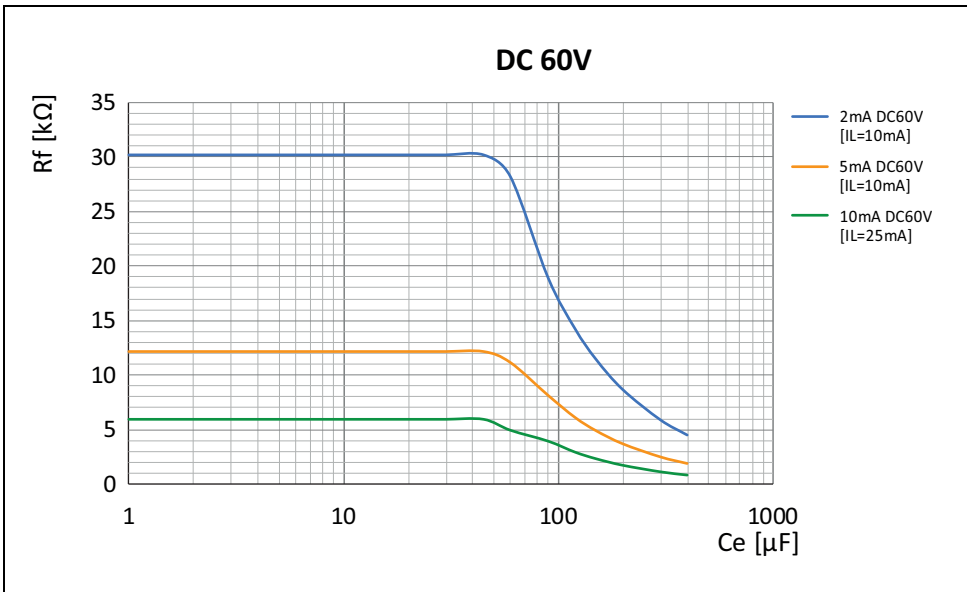
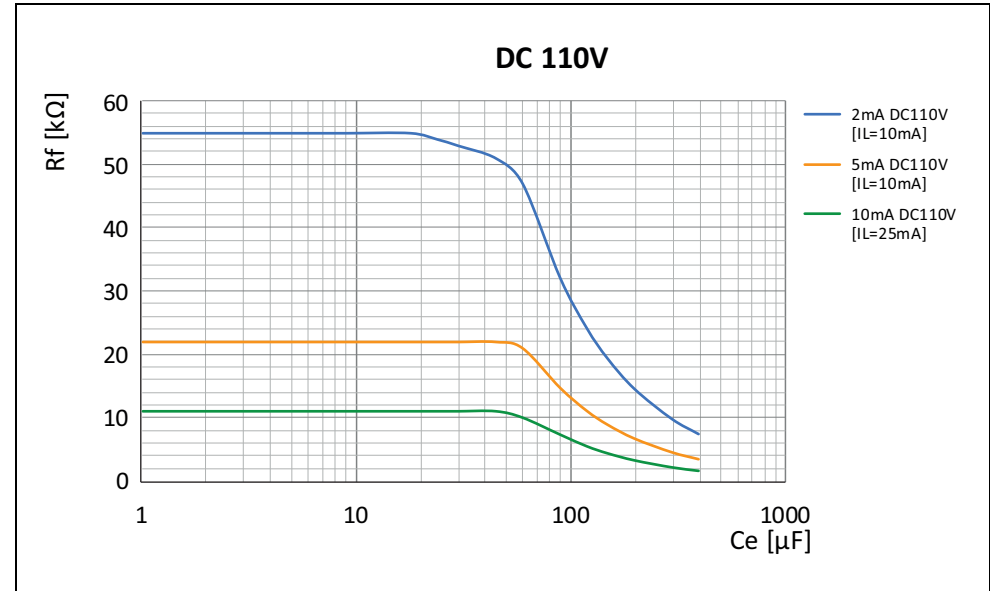
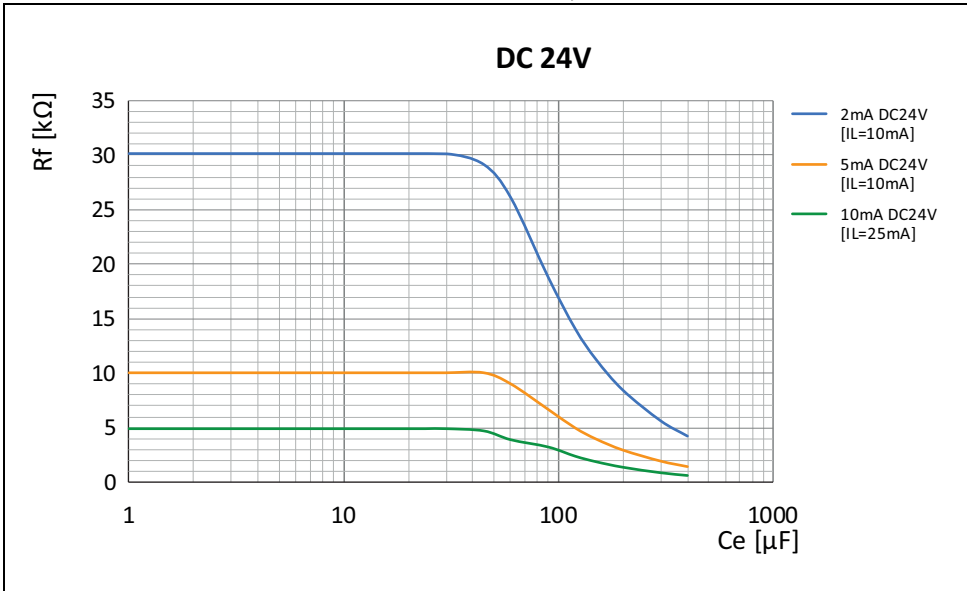

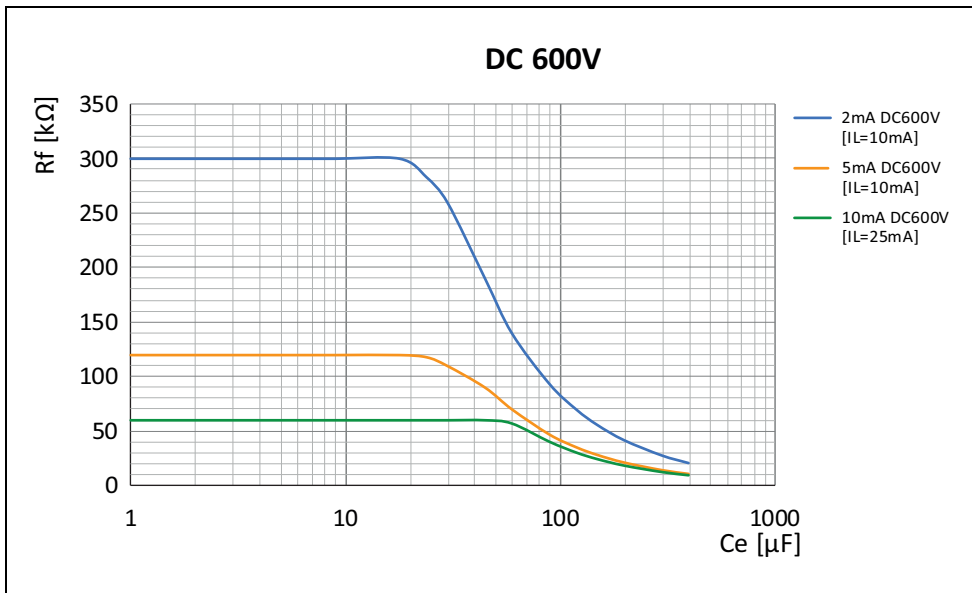
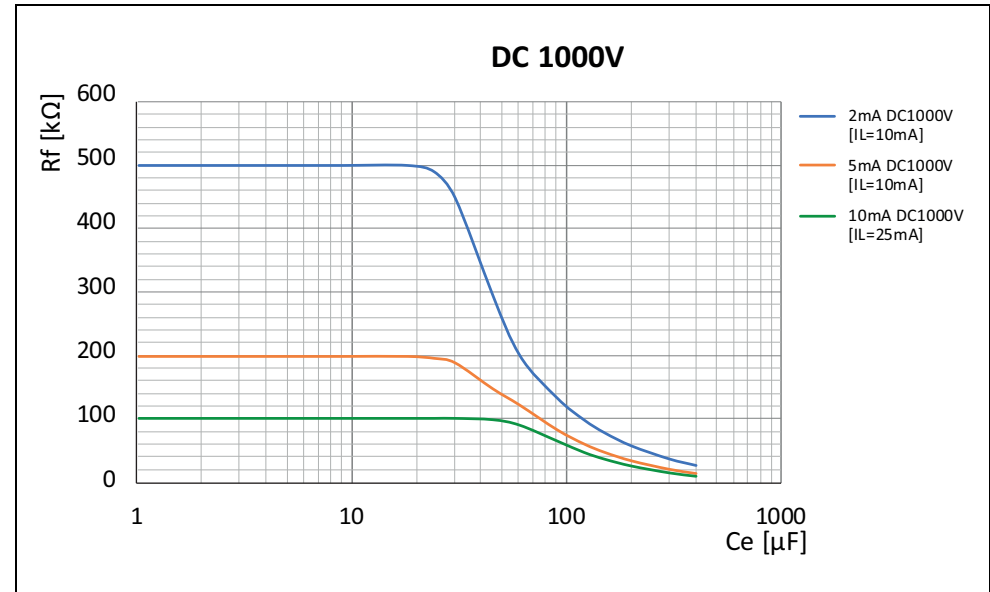
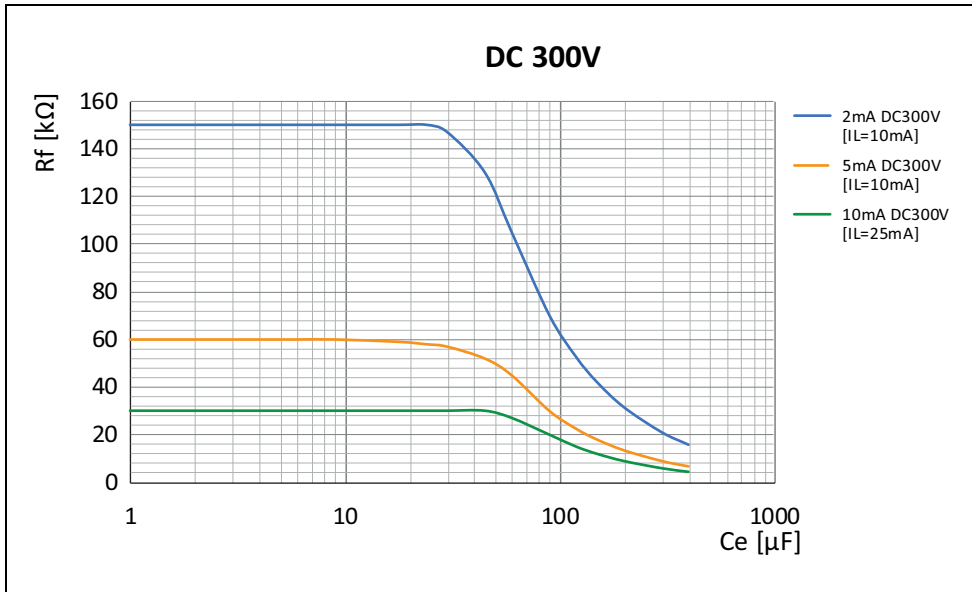

### 12.1.4 Characteristic curves EDS441 for AC systems

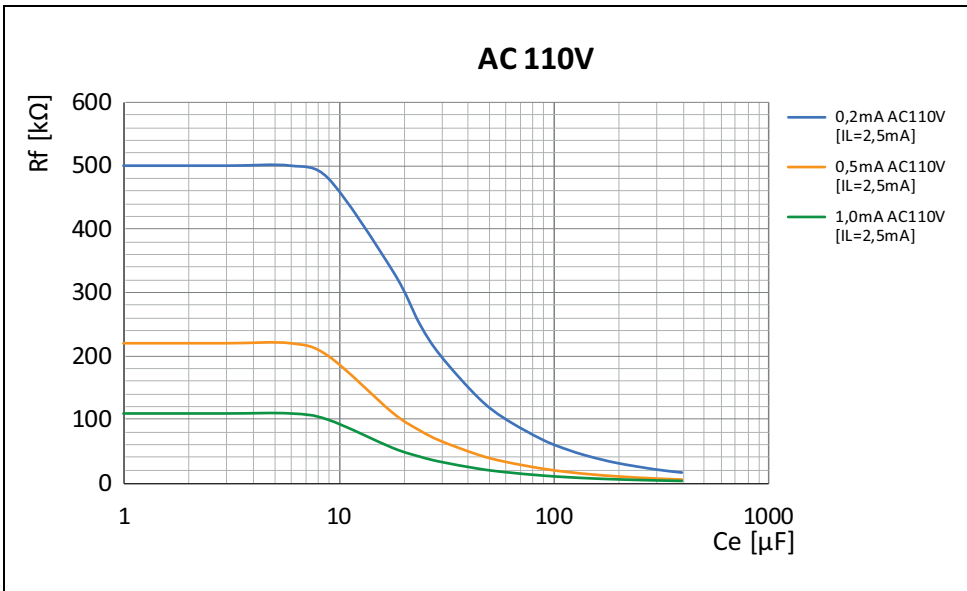
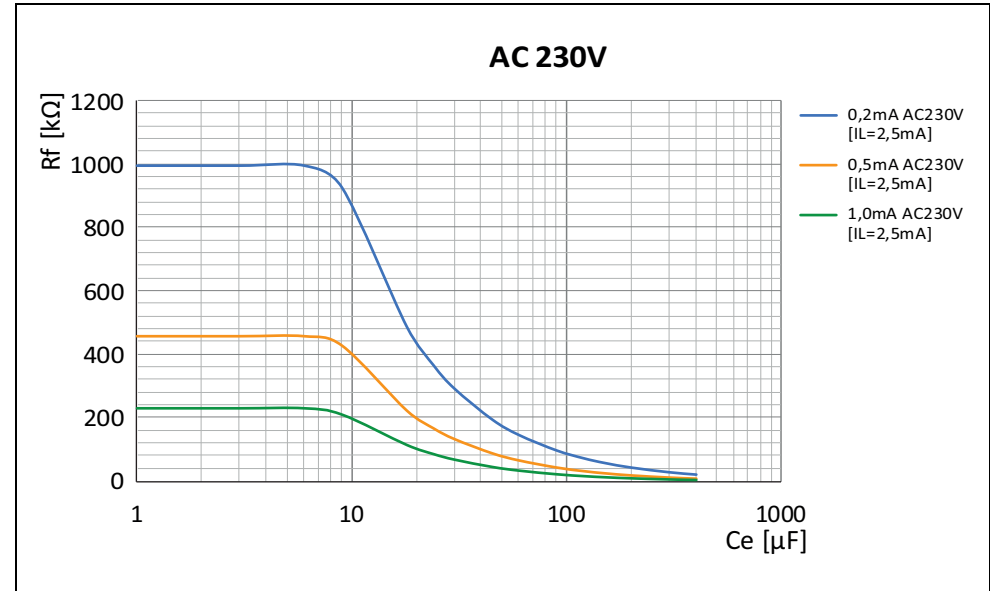
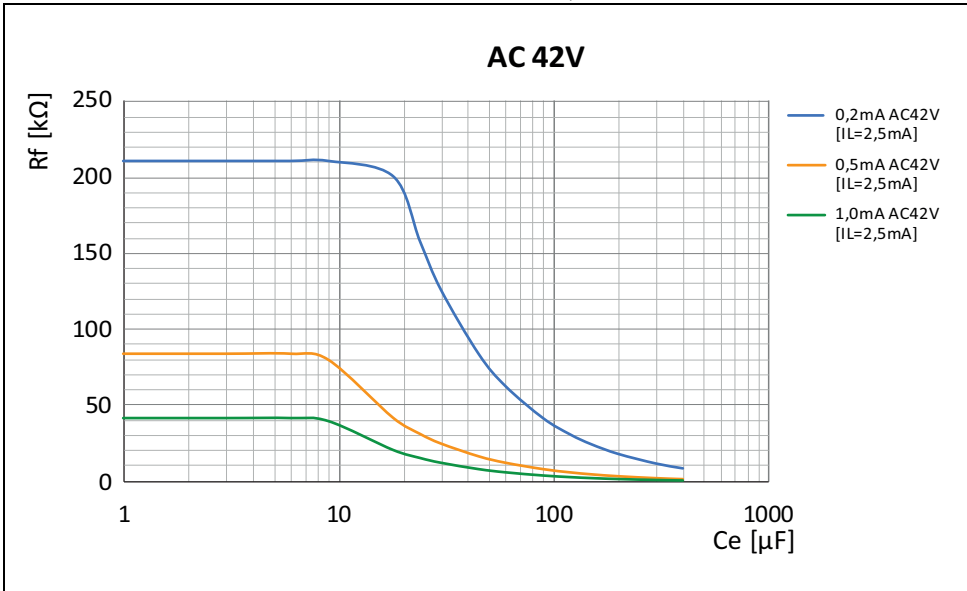

### 12.1.5 Characteristic curves EDS441 for DC systems

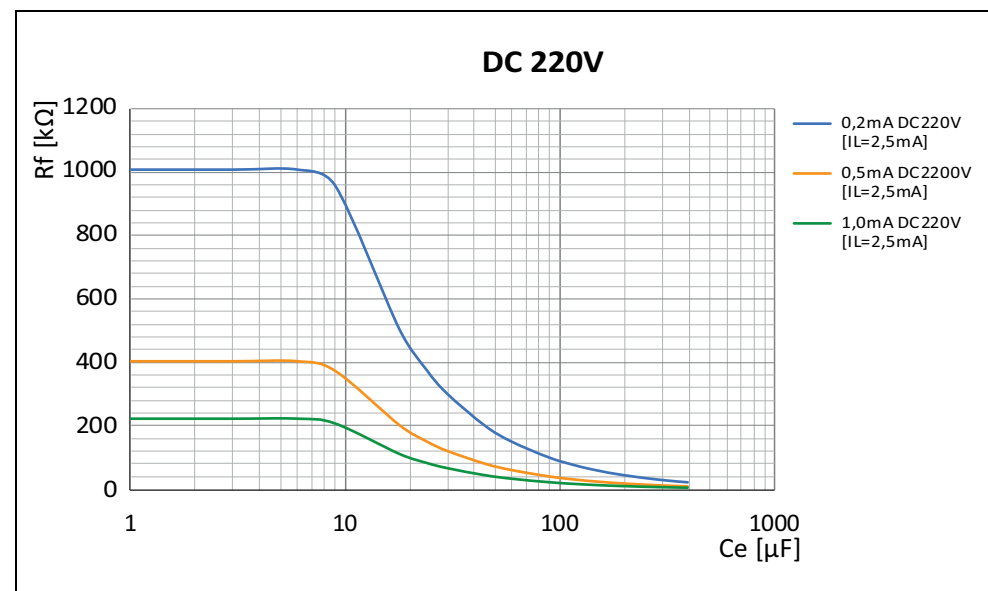
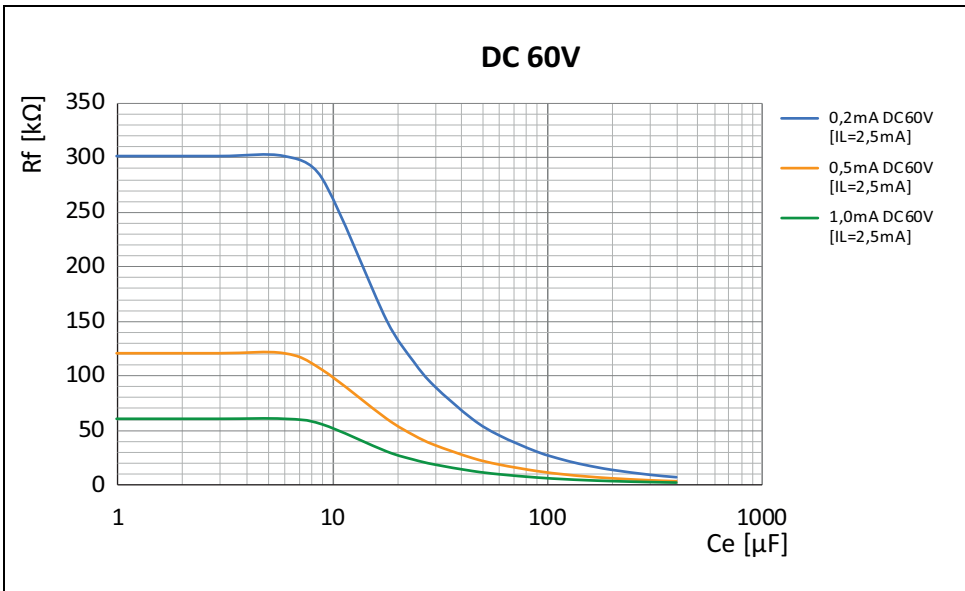
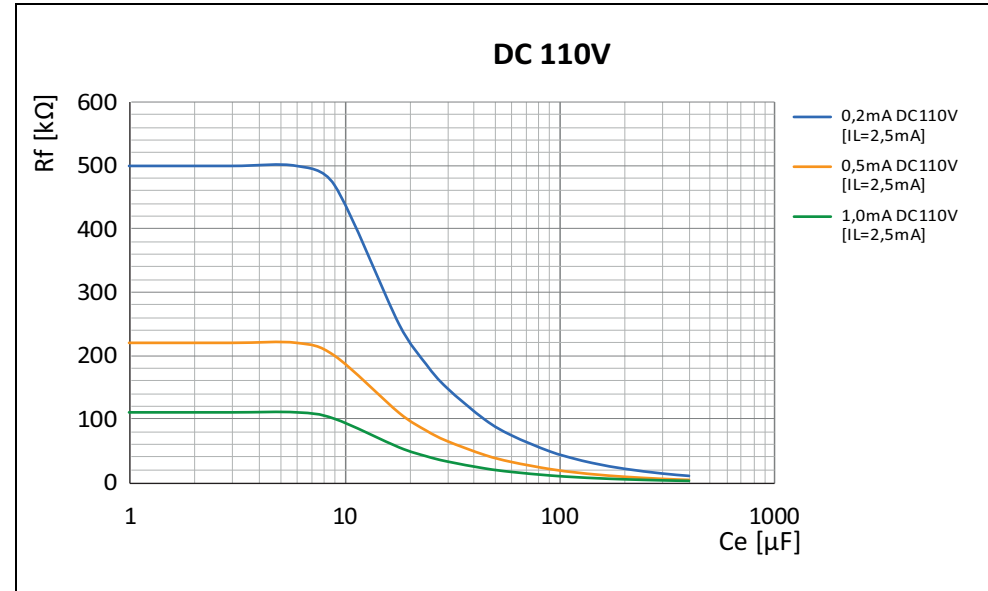
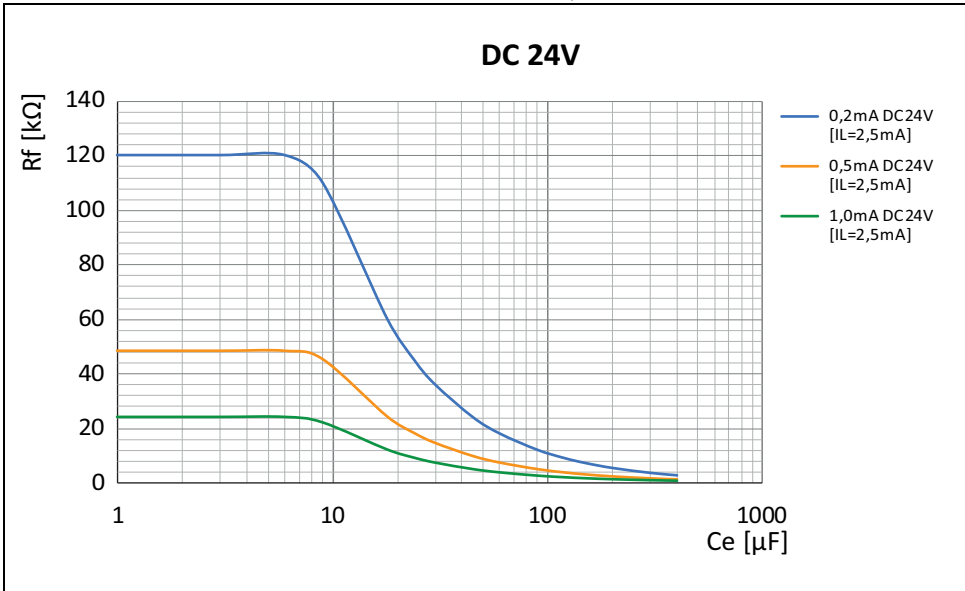

### 12.1.6 Characteristic curves EDS441-LAB for AC systems

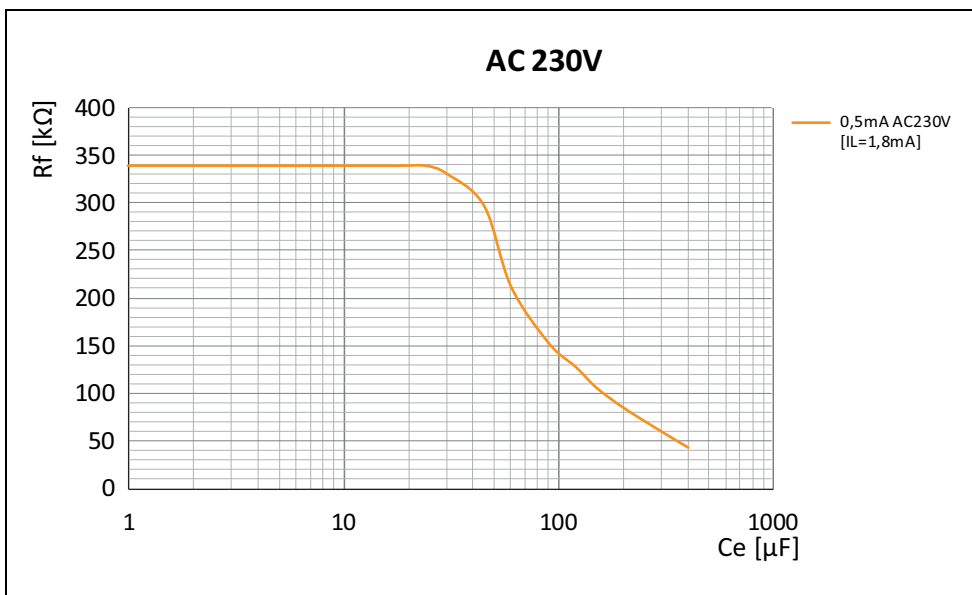
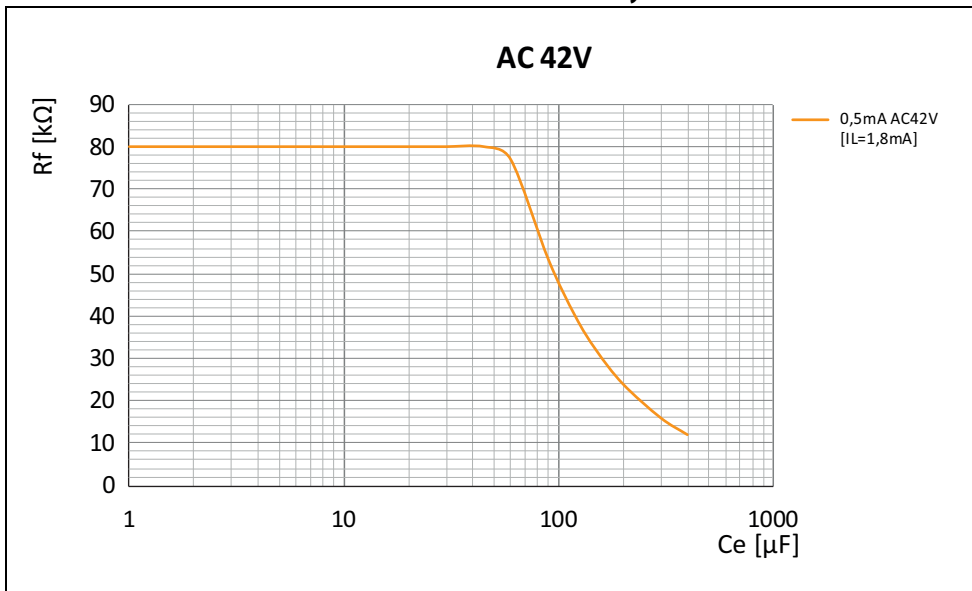

### 12.1.7 Characteristic curves EDS441-LAB for DC systems

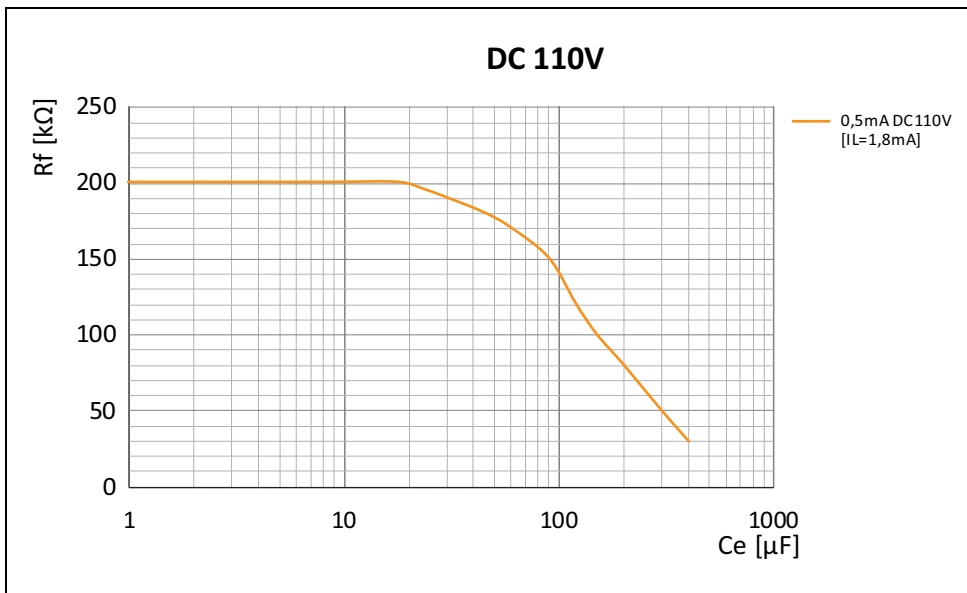
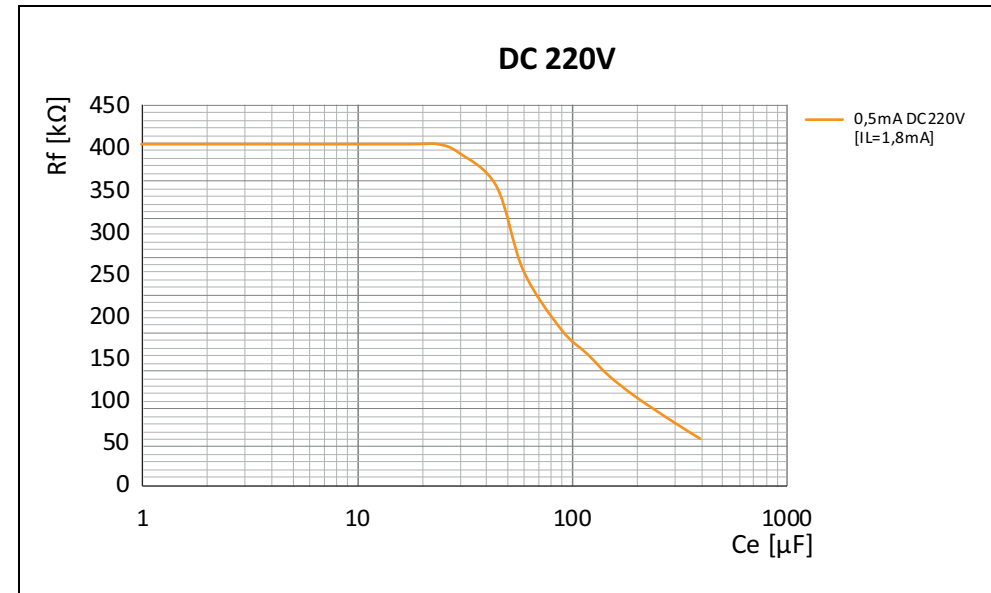
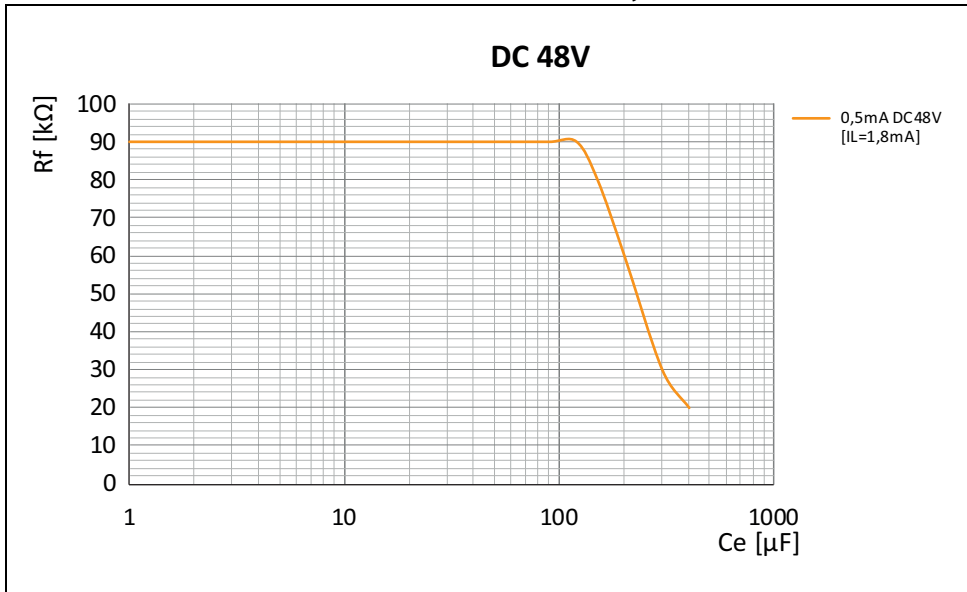

### 12.1.8 Response values EDS440-LAF for DC systems up to a system leakage capacitance of max. 100 $\mu$ F:

Nominal voltage	Max. insulation fault $R_F$
<b>DC 60 V</b>	2 kOhm
<b>DC 110 V</b>	5 kOhm
<b>DC 220 V</b>	10 kOhm
<b>DC 300 V</b>	15 kOhm
<b>DC 600 V</b>	30 kOhm
<b>DC 1000 V</b>	50 kOhm

### 12.1.9 Response values EDS440-LAF for AC systems up to a system leakage capacitance of max. 100 $\mu$ F:

Nominal voltage	Max. insulation fault $R_F$
<b>1AC 110 V</b>	2 kOhm
<b>1AC 230 V</b>	5 kOhm
<b>1AC 400 V</b>	10 kOhm
<b>3AC 230 V</b>	15 kOhm
<b>3AC 400 V</b>	25 kOhm
<b>3AC 500 V</b>	30 kOhm
<b>3AC 690 V</b>	40 kOhm



## 12.2 Fault curve EDS440

An insulation fault location beyond the grey area causes an error message. The EDS44x-L indicates error messages via flashing LEDs (refer to "Service and COM LED light up simultaneously and continuously." on page 26).

If you use an EDS44x-S, the fault messages are indicated via the ISOMETER®.

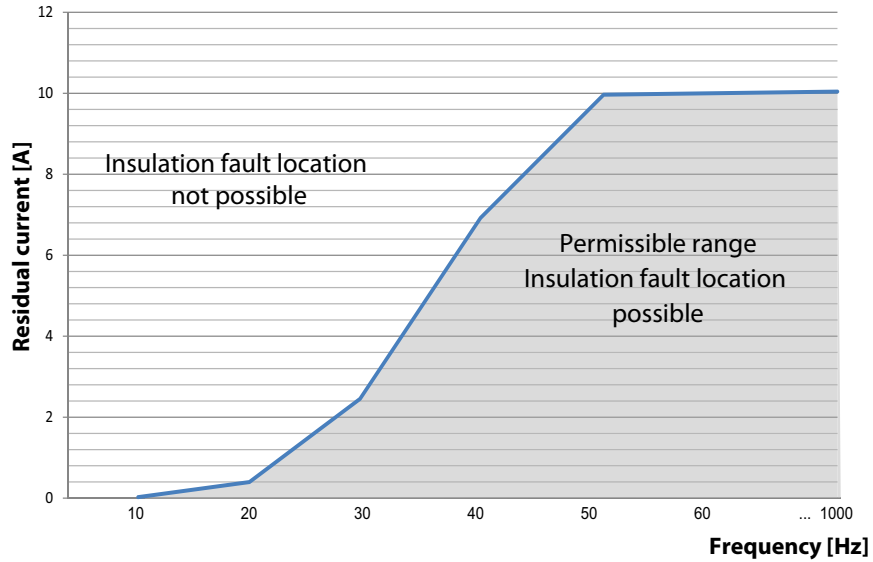

## 12.3 Fault curve EDS441

An insulation fault location beyond the grey area causes an error message. The EDS44x-L indicates error messages via flashing LEDs (refer to "Service and COM LED light up simultaneously and continuously." on page 26).

If you use an EDS44x-S, the fault messages are indicated via the ISOMETER®.

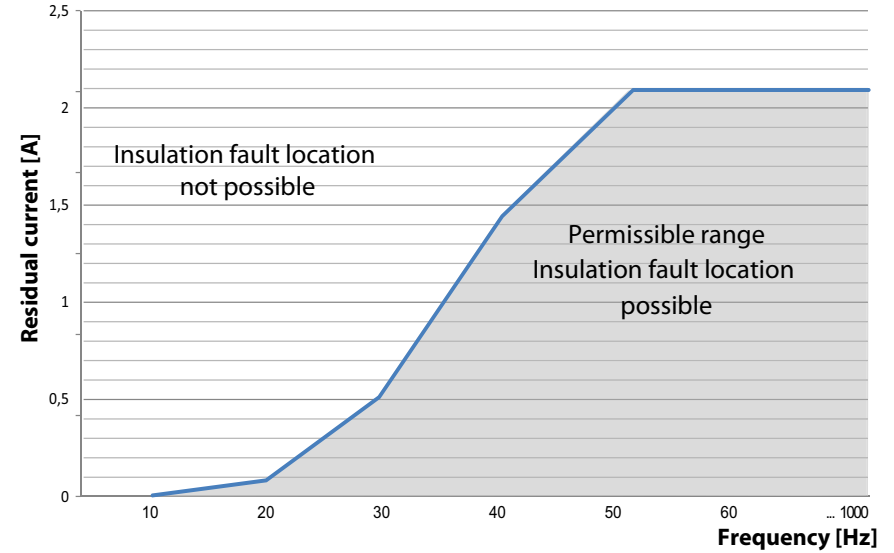

## 13.1 Tabular data

### Insulation coordination acc. to IEC 60664-1/IEC 60664-3

#### Definitions

Supply circuit (IC1) .....	A1, A2
Output circuit 1 (IC2) .....	13, 14
Output circuit 2 (IC3) .....	23, 24
Control circuit (IC4) .....	(A1, A2), (13,14)-(23,24)-(X1, X3)

Rated voltage.....1000 V

Overvoltage category..... III

Range of use..... ≤ 2000 m AMSL

#### Rated impulse voltage

IC1/(IC2-4) .....	4 kV
IC2/(IC3-4) .....	4 kV
IC3/(IC4) .....	4 kV

#### Rated insulation voltage

IC1/(IC2-4) .....	AC 250 V
IC2/(IC3-4) .....	250 V
IC3/IC4 .....	250 V
Pollution degree outside ( $U_n < 690$ V) .....	3
Pollution degree outside ( $U_n > 690 < 1000$ V) .....	2

#### Protective separation (reinforced insulation) between

IC1/(IC2-4) .....	Overvoltage category III, 1000 V
IC2/(IC3-4) .....	Overvoltage category III, 300 V
IC3/IC4 .....	Overvoltage category III, 300 V

#### Voltage tests (routine test) acc. to IEC 61010-1

IC2/(IC3-4) .....	AC 2.2 kV
IC3/IC4 .....	AC 2.2 kV

### Supply voltage

Supply voltage range  $U_s$  EDS44...-L ( ... -LAB, ... -LAF) .....

AC/DC 24 ... 240 V

Supply voltage range  $U_s$  EDS44...-S .....

DC 24 V

Tolerance of  $U_s$  .....

-20 ... +15 %

Frequency range of  $U_s$  .....

DC, 50 ... 400 Hz<sup>1) 2)</sup>

Tolerance of the frequency range of  $U_s$  .....

-5 ... +15 %

Power consumption, typically 50 Hz (400 Hz) EDS44...-L .....

≤ 4 W/7 VA (≤ 4 W, 28 VA)

Power consumption, typically (DC via BB bus) EDS44...-S .....

≤ 1 W

### Response values

Response value insulation fault location ( $I_{\Delta L}$ ) EDS440 .....

2 ... 10 mA

Response value insulation fault location ( $I_{\Delta L}$ ) EDS441 .....

0.2 ... 1 mA

Relative uncertainty ( $I_{\Delta L}$ ) EDS440 .....

±30 %, min. ±2 mA<sup>3)</sup>

Relative uncertainty ( $I_{\Delta L}$ ) EDS441 .....

±30 %, min. ±0.2 mA<sup>3)</sup>

Response value residual current measurement ( $I_{\Delta n}$ ) EDS440 .....

100 mA ... 10 A

Response value residual current measurement ( $I_{\Delta n}$ ) EDS441 .....

100 mA ... 1 A

Relative uncertainty ( $I_{\Delta n}$ ) EDS44x (42 ... 60 Hz) .....

±5 %

Relative uncertainty ( $I_{\Delta n}$ ) EDS44x (61 ... 1000 Hz) .....

-20 ... 0 %

Hysteresis .....

20 %

### Time response

Scanning time for all channels insulation fault location ( $I_{\Delta L}$ ) .....

profile-dependent, min. 6 s

Response time residual current measurement ( $I_{\Delta n}$ ) .....

≤ 400 ms

Response time for measuring current transformer monitoring .....

max. 18 min

### Measuring circuit

Nominal system voltage  $U_n$  EDS440 .....

refer to locating current injector (e.g. ISOMETER® iso685-D-P)

Nominal system voltage  $U_n$  EDS441 .....

AC 230 V, DC 220 V

Tolerance of  $U_n$  EDS441 .....

AC ±15 %, DC ±40 %

Measuring current transformers external for EDS440 type .....

W ... , WR ... , WS ...

Measuring current transformers external for EDS441 type .....

W ... /8000, WS ... /8000

Measuring current transformers external for EDS441-LAB .....

W ... AB

Measuring current transformers external for EDS440-LAF .....

CTAF ...

Load EDS440 .....

47 Ω

Load EDS441, EDS440-LAF .....

1.5 kΩ

Rated insulation voltage measuring current transformers .....

800 V

### Connection EDS measuring current transformers

Single wire ≥ 0.75 mm<sup>2</sup> .....

0 ... 1 m

Single wire, twisted ≥ 0.75 mm<sup>2</sup> .....

1 ... 10 m

Shielded cable ≥ 0.5 mm<sup>2</sup> .....

10 ... 40 m

Recommended cable (shielded, shield connected to PE on one side) .....

J-Y (St) Y min. 2 x 0.8

### Measuring ranges insulation fault location $I_{\Delta L}$

Rated frequency range .....

DC, 16.7 ... 1000 Hz

Measuring range insulation fault location ( $I_{\Delta L}$ ) EDS440 .....

1.5 ... 50 mA

Measuring range insulation fault location ( $I_{\Delta L}$ ) EDS441 .....

0.15 ... 5 mA

Maximum permissible residual current .....

refer to "Diagrams" chapter

### Measuring range residual current measurement $I_{\Delta n}$

Measuring range residual current measurement ( $I_{\Delta n}$ ) EDS440 .....

100 mA ... 20 A

Rated frequency range EDS440-x .....

50 ... 1000 Hz

Measuring range residual current measurement ( $I_{\Delta n}$ ) EDS441 .....

100 mA ... 2 A

Rated frequency range EDS441-x .....

50 ... 60 Hz

### LEDs

ON (operation LED) .....

green

COM .....

yellow

SERVICE .....

yellow

$I_{\Delta L}$  ALARM .....

yellow

$I_{\Delta n}$  ALARM .....

yellow

1 ... 12 channel indication .....

yellow

**Digital inputs**

Number.....	2
Operating mode, adjustable.....	active high, active low
Function.....	none, test, reset
Voltage level.....	Low DC -5...5 V, High DC 11...32 V

**Digital current output**

Number.....	1
Function.....	none, I <sub>ΔL</sub> alarm, I <sub>Δn</sub> alarm, device error, current transformer connection fault, common alarm, BS bus malfunction
Current.....	0 mA DC inactive, 20 mA DC active
Tolerance.....	±10 %
Load resistance.....	$R \leq 500 \Omega/P_R \geq 0.25 \text{ W}$

**Buzzer**

Number.....	1
Function.....	none, I <sub>ΔL</sub> alarm, I <sub>Δn</sub> alarm, device error, transformer connection fault, insulation fault location active, common alarm

**Interfaces**

Interface/protocol.....	RS-485   BS bus   Modbus RTU
Data rate BS bus.....	9.6 kBaud/s
Data rate Modbus RTU.....	9.6   19.2   37.4   57.6   115 kBaud/s
Cable length.....	≤ 1200 m
Cable: twisted pair, one end of shield connected to PE.....	recommended: J-Y (St) Y min. 2 x 0.8
Connection.....	X1.A, X1.B
Terminating resistor.....	120 Ω, can be activated internally
Device address, BS bus.....	0, 2...79 (optional 0, 2...159)

**Switching elements**

Number.....	2 N/O contacts
Operating mode.....	N/C operation / N/O operation
Function contact 13,14.....	none, I <sub>ΔL</sub> alarm, I <sub>Δn</sub> alarm, device error, CT connection fault, common alarm, BS bus malfunction
Function contact 23,24.....	none, I <sub>ΔL</sub> alarm, I <sub>Δn</sub> alarm, device error, CT connection fault, common alarm, BS bus malfunction
Electrical endurance under rated operating conditions.....	30000 hrs.
Rated operational voltage.....	AC 250 V
Rated operational current.....	7 A
Rated insulation voltage.....	4 kV

**Contact data acc. to IEC 60947-5-1**

Utilization category.....	AC-13/AC-14/DC-12/DC-12/DC-12/DC-12
Rated operational voltage.....	230 V/230 V/24 V/48 V/110 V/220 V
Rated operational current.....	5 A/3 A/1 A/1 A/0.2 A/0.1 A
Max. switching capacity.....	300 W/2770 VA
Max. switching voltage.....	DC 30 V/AC 277 V
Minimum contact rating.....	1 mA at AC/DC ≥ 10 V



**Environment/EMC**

EMC.....	IEC 61326-2-4 <sup>4)</sup>
----------	-----------------------------

**Ambient temperatures**

Operating temperature.....	-25...+55 °C
Transport.....	-40...+85 °C
Storage.....	-25...+70 °C

Classification of climatic conditions acc. to IEC 60721:

Stationary use (IEC 60721-3-3).....	3K23 (no condensation, no formation of ice)
Transport (IEC 60721-3-2).....	2K11
Long-term storage (IEC 60721-3-1).....	1K22

Classification of mechanical conditions acc. to IEC 60721:

Stationary use (IEC 60721-3-3).....	3M11
Transport (IEC 60721-3-2).....	2M4
Long-term storage (IEC 60721-3-1).....	1M12

**Connection**

Connection type.....	pluggable screw-type terminal or push-wire terminal
----------------------	---

**Screw-type terminals:**

Tightening torque.....	0.5...0.6 Nm (5...7 lb-in)
Conductor sizes.....	AWG 24-12
Stripping length.....	7 mm
rigid/flexible.....	0.2...2.5 mm <sup>2</sup>
flexible with ferrule, with/without plastic sleeve.....	0.25...2.5 mm <sup>2</sup>
Multiple conductor, rigid.....	0.2...1 mm <sup>2</sup>
Multiple conductor, flexible.....	0.2...1.5 mm <sup>2</sup>
Multiple conductor, flexible with ferrule without plastic sleeve.....	0.25...1 mm <sup>2</sup>
Multiple conductor, flexible with TWIN ferrule with plastic sleeve.....	0.5...1.5 mm <sup>2</sup>

**Push-wire terminals:**

Conductor sizes.....	AWG 24-12
Stripping length.....	10 mm
rigid/flexible.....	0.2...2.5 mm <sup>2</sup>
flexible with ferrule, with/without plastic sleeve.....	0.25...2.5 mm <sup>2</sup>
Multiple conductor, flexible with TWIN ferrule with plastic sleeve.....	0.5...1.5 mm <sup>2</sup>

**Push-wire terminals X1, X2:**

Conductor sizes.....	AWG 24-16
Stripping length.....	10 mm
rigid/flexible.....	0.2...1.5 mm <sup>2</sup>
flexible with ferrule without plastic sleeve.....	0.25...1.5 mm <sup>2</sup>
flexible with ferrule with plastic sleeve.....	0.25...0.75 mm <sup>2</sup>

**Other**

Operating mode.....	continuous operation
Mounting.....	at an ambient temperature > 55 °C vertical mounting required at an ambient temperature < 55 °C mounting optional
Degree of protection internal components .....	IP40
Degree of protection terminals .....	IP20
DIN rail mounting acc. to.....	IEC 60715
Screw fixing .....	2 x M4 with mounting clip
Enclosure material.....	polycarbonate
Flammability class.....	UL 94V-0
Dimensions (W x H x D) .....	72 x 93 x 63
Weight.....	approx. 122 g (EDS44x-S) approx. 242 g (EDS44x-L, ...-LAB, ...-LAF)

**"W" option data deviating from the standard version**

Devices with the suffix "W" feature increased shock and vibration resistance. The electronics is covered with a special varnish to provide increased protection against mechanical stress and moisture.

Ambient temperatures:

Operating temperature.....	-40...+70 °C
Transport.....	-40...+85 °C
Long-term storage .....	-25...+70 °C

Classification of climatic conditions acc. to IEC 60721:

Stationary use (IEC 60721-3-3).....	3K23 (condensation and formation of ice possible)
-------------------------------------	---

Classification of mechanical conditions acc. to IEC 60721:

Stationary use (IEC 60721-3-3).....	3M11
-------------------------------------	------

- <sup>1)</sup> = At a frequency > 200 Hz, the connection of X1 and k1-12/l1-12 must be insulated.  
Only permanently installed devices which at least have overvoltage category CAT2 (300 V) may be connected.
- <sup>2)</sup> = Only 50/60 Hz are permitted for UL applications.
- <sup>3)</sup> = Residual current effect of > 100 mA results in a greater relative uncertainty.
- <sup>4)</sup> = This equipment is not intended for use in residential environments and may not provide adequate protection to radio reception in such environments.

**13.2 Standards and certifications**

Observe the applicable national and international standards. The EDS44x series meets the device standards:

- DIN VDE 0100-410 (VDE 0100-410)
- DIN EN 61557-9 (VDE 0413-9)
- IEC 61557-9
- DIN EN 50155 (VDE 0115-200)
- DIN EN 45545-2:2016

Subject to change! The specified standards take into account the edition valid until 08/21 unless otherwise indicated.

The operating manuals for the individual system components provide you with information about the standards that apply to that particular device.



**13.3 Ordering details**

**13.3.1 Insulation fault locators**

Type	Supply voltage $U_S^*$	Response value	Art. No.
EDS440-S-1	DC 24 V	2...10 mA	B91080201
EDS440W-S-1	DC 24 V	2...10 mA	B91080201W
EDS440-L-4	AC/DC 24...240 V	2...10 mA	B91080202
EDS440W-L-4	AC/DC 24...240 V	2...10 mA	B91080202W
EDS441-S-1	DC 24 V	0.2...1 mA	B91080204
EDS441W-S-1	DC 24 V	0.2...1 mA	B91080204W
EDS441-L-4	AC/DC 24...240 V	0.2...1 mA	B91080205
EDS441W-L-4	AC/DC 24...240 V	0.2...1 mA	B91080205W
EDS441-LAB-4	AC/DC 24...240 V	0.2...1 mA	B91080207
EDS441W-LAB-4	AC/DC 24...240 V	0.2...1 mA	B91080207W
EDS440-LAF-4	AC/DC 24...240 V	10 mA	B91080209

\* Absolute values

### 13.3.2 Accessories

Description	Art. No.
EDS440/441 mechanical accessories comprising: terminal cover and 2 mounting clips (scope of delivery)	B91080903
EDS440/441 plug kit, screw terminals (scope of delivery)	B91080901
EDS440 441 plug kit, push-wire terminals	B91080902
BB bus 4TE plug connection (scope of delivery EDS44x(W)-S-1)	B98110002

Type	Supply voltage $U_S$	Art. No.
DI-1 PSM (RS-485 repeater)	AC/DC 24 V $\pm 20\%$	B95012044
DI-2 USB (interface converter RS-485/USB) with USB cable	Supplied by USB interface	B95012045
IOM441-S (input/output module)	12-way relay module	B95012057
AN420 (power supply unit for W...AB current transformers)	AC, 100...250 V 50/60 Hz, DC $\pm 12$ V	B74053100 B94053100
AN471 (power supply unit for DI-1 or DI-2)	AC 230 V 50/60 Hz AC, DC 20 V	B924189
Snap-on mounting W20.../35...		B98080501
Snap-on mounting W60...		B98080502

### 13.3.3 Measuring current transformers for EDS440

Bender measuring current transformers

Type	Internal diameter/mm	Design type	Art. No.
CTAC20	20	rund	B98110005
CTAC35	35	rund	B98110007
CTAC60	60	rund	B98110017
CTAC120	120	rund	B98110019
CTAC120	210	rund	B98110020

Alternative measuring current transformers from the Bender program

Type	Internal diameter/mm	Design type	Art. No.
W10/600	10	circular	B911761
W0-S20	20	circular	B911787
W1-S35	35	circular	B911731
W2-S70	70	circular	B911732
W3-S105	105	circular	B911733
W4-S140	140	circular	B911734
W5-S210	210	circular	B911735
WR 70x175S	70x175	rectangular	B911738
WR 115x305S	115x305	rectangular	B911739
WR 150x350S	150x350	rectangular	B911740
WR 200x500S	200x500	rectangular	B911763
WS 50x80S	50x80	split-core	B911741
WS 80x80S	80x80	split-core	B911742
WS 80x120S	80x120	split-core	B911743
WS 80x160S	80x160	split-core	B911755

For further information regarding the measuring current transformers, refer to the data sheets

### Measuring current transformers for EDS441

Bender measuring current transformers

Type	Internal diameter/mm	Design type	Art. No.
CTAC20/1	20	rund	B98110006
CTAC35/1	35	rund	B98110008

Alternative measuring current transformers from the Bender program

Type	Internal diameter/mm	Design type	Art. No.
W10/8000	10	circular	B911759
W1-35/8000	35	circular	B911756
WS20x30/8000	20 x 30	split-core	B911764
WS50x80/8000	50 x 80	split-core	B911757
W10/8000-6	10	circular, 6-fold	B911900

For further information regarding the measuring current transformers, refer to the data sheets.

### Measuring current transformers for EDS441-LAB

Bender measuring current transformers

Type	Internal diameter/mm	Design type	Art. No.
CTUB104 -CTBC20P	20	rund	B78120033
CTUB104 -CTBC35P	35	rund	B78120034
CTUB104 -CTBC60P	60	rund	B78120035

For further information regarding the measuring current transformers, refer to the data sheets.

### Measuring current transformers for EDS440-LAF

Bender measuring current transformers

Type	mm	Design type	Art. No.
CTAF500SET	500	flexible	B98110022
CTAF1000SET	1000	flexible	B98110023

For further information regarding the measuring current transformers, refer to the data sheets.

### 13.3.4 Changelog

Date	Version	Software version	Changes
11.2020	08	---	Cover: Software > 2000 5.10.2: Wiring diagram modified 12.1.9: Nominal system voltages modified 13.3.3: Measuring CTs of CTxx series included / discontinued series removed
02.2022	09	---	Editorial revision 4.4 / 5.10: X2 interface is be pcedised. 13.2: DIN EN 45545-2:2016 included, UKCA included

## A

Accessories 53  
Alarm messages 25, 38

## B

BB bus 16  
Bedienung  
  Tasten 29  
BS bus  
  BS address 31

## Buttons

MUTE 33  
RESET 33  
TEST 33

Buzzer 33

## C

Cables, shielded 18  
Commissioning 28  
  Commissioning flow chart 29  
  Switching on 28  
Compatibility 9  
Connection  
  3(N)AC system 22  
  AC system 21  
  Connection example 23  
  DC system 20  
  k1-12/I1-12 interface 17  
  Measuring current transformers 18, 19  
  X1 interface 17

## D

Digital outputs

Buzzer 33  
Dimensions 12  
Display 24  
  Alarm messages 25  
  Operating and display elements EDS...-L 24  
  Operating and display elements EDS...-S 24  
  Standard display EDS...-L 25  
  Standard display EDS...-S 25

## E

Einstellungen  
  Profil 30

## F

Factory settings 37  
Fault curve 48

## H

Hazards when handling the device 8

## I

Inspection 7  
Insulation fault locators  
  Compatibility 10  
  Overview 9

## Interface

RS-485 30

## Interfaces

BS bus 30

## M

Measuring current transformers 18, 19, 53, 54  
Mounting  
  DIN rail mounting 15  
  Screw mounting 14

## O

Operating mode 25  
Ordering details 52

## R

Relays 36  
Response sensitivity 39  
RS-485 interface 30

## S

Settings 34  
  Digital inputs EDS44...-L 35  
  Digital outputs EDS44...-L 36  
  Factory settings 37  
  Fault memory 35  
  Function of the digital inputs 35  
  Function of the digital outputs 36  
  Insulation fault location mode 34  
  Locating current 34  
  Locating current injector 34  
  Profile 31  
  Relays 36  
  Test 36  
  Trigger 34  
Sicherheitshinweise 5  
Standards 8, 9, 50

## T

Technical data 39  
Test 36  
  Testing the device function 33  
Testing the device 8



**Bender GmbH & Co. KG**

Postbox 1161 • 35301 Grünberg • Germany  
Londorfer Straße 65 • 35305 Grünberg • Germany

Tel.: +49 6401 807-0  
Fax: +49 6401 807-259

E-Mail: [info@bender.de](mailto:info@bender.de)  
Web: [www.bender.de](http://www.bender.de)

**Customer service**

Service hotline: 0700-BenderHelp (Telephone und Fax)  
Carl-Benz-Straße 8 • 35305 Grünberg • Germany

Tel.: +49 6401 807-760  
Fax: +49 6401 807-629

E-Mail: [info@bender-service.com](mailto:info@bender-service.com)  
Web: <http://www.bender.de>



**BENDER Group**