

Improving productivity for heavy industries and applications

PowerFlex® 6000 and 7000 medium voltage AC drives
Powerful performance. Flexible control



Allen-Bradley

by ROCKWELL AUTOMATION

Benefits of Allen-Bradley® PowerFlex medium voltage AC drives



Application expertise

With over 30 years of experience and thousands of applications in a wide variety of industries, our medium voltage drives deliver proven results that you can rely on. Our application and test engineers, project management teams, and field service engineers develop and deliver solutions that will meet your needs.



Intelligent motor control – a connected enterprise

Our medium voltage drives provide valuable information about drive health and process parameters to the control system. Full support of Studio 5000® and Connected Components Workbench™ software tools minimize the time and effort required to integrate these smart assets into your control system.

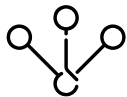

Connectivity

Our medium voltage drives offer built in EtherNet/IP communication and support other typically used communication protocols. Flexible connectivity and control system compatibility helps deliver seamless control system integration.

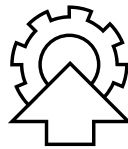

Proven reliability

Robust design guidelines, reliable components, low parts count, control power ride-through, and automatic restart capabilities inherently provide maximized up-time. Redundant critical components and bypass options, coupled with factory testing on a dynamometer before shipment, all contribute to improved asset utilization.



Safety / quality standards

Quality has always been a signature of the Allen-Bradley brand. Our drive portfolio meets all relevant global UL and IEC standards. Arc-resistant enclosure options and functional safety options help optimize the safety for your personnel and processes.

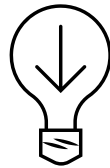

Energy efficiency

ECO design cooling fans and high efficiency isolation transformers maximize system efficiency and lower operating costs. Transformerless configurations help deliver the highest system efficiency.



Targeted product portfolio

Our portfolio offering is tailored to meet the needs of all-purpose fan, pump, and compressor applications up to 120 Hz or special purpose mixer, conveyor, crane and hoist applications.



Global support

Our extensive installed base is supported by a worldwide service and support network to help wherever and whenever you need it.



The industries and applications we serve

Oil & gas



- Oil pipeline pumps
- Natural gas pipeline compressors
- Electrical submersible pumps
- Induced draft fans

Power generation



- Feedwater pumps
- Induced draft fans
- Forced draft fans

Forest products



- Fan pumps
- Induced draft fans
- Boiler feedwater pumps
- Pulpers
- Refiners

Marine



- Main propulsion
- Positioning thrusters

Water / wastewater



- Raw sewage pumps
- Effluent pumps
- Low service/raw water pumps
- High service/finished water pumps
- Aeration blowers
- Flood control pumps

Commercial



- HVAC/OEM chillers/compressors
- Airport cogeneration
- Hospital cogeneration
- University cogeneration

Mining, steel & cement



- Slurry pumps
- Ventilation fans
- Descaling pumps
- Conveyors
- Induced draft fans
- Mills

Other



- Test stands
- Wind tunnels
- Agitators
- Rubber mixers



Selecting the right drive for your application



Rockwell Automation medium voltage drives are divided into two segments based on application requirements.

All-purpose drives

- Includes the performance characteristics required to operate fans, pumps, compressors, conveyors and mills and high-speed applications up to 120 Hz.

Special purpose drives

- Includes enhanced characteristics to operate specialty applications such as conveyors, ball and sag mills, extruders and mixers.

Category	All-Purpose	Special Purpose
Product	<p>PowerFlex 6000 Drives</p> 	<p>PowerFlex 7000 Drives</p> 
Typical Applications	Fans, Pumps, Compressors, Conveyors, Mills and Chillers	Fans, Pumps, Compressors, Chillers, Hoists, Cranes, Conveyors, Mixers, Extruders, Ball and SAG Mills, Electrical Submersible Pumps
Drive Cooling	Air	Air or Liquid
Topology	Cascaded H-Bridge	CSI PWM
Rectifier Type	18...54 Pulse Diode	Active Front End SGCT or 18-Pulse SCR
Inverter Type	IGBT	SGCT
Power Range	100...11,000 kW (150...15,000 Hp)	150...6300 kW (200...8500 Hp)
Output Voltage	2.3...11 kV	2.3...6.6 kV
Output Frequency	0.3/0.6* ...120 Hz (* with encoder)	0.1...90 Hz
Direction - Torque	Forward and Reverse, Motoring	Forward and Reverse, Motoring and Regeneration
Type of Motor	Induction	Induction and Synchronous

PowerFlex 6000T AC drives

Simple. Connected. Easy-to-use

A common control architecture and TotalFORCE® technology

Simplify your integration and operating experience by choosing PowerFlex 6000T MV drives. They share the same control hardware, firmware and network interface software used in our latest generation of PowerFlex 755T low voltage drives. Using a common control platform across your entire installed base of variable frequency drives lowers integration, operation and support costs. A common platform also reduces product-specific training requirements and spare parts inventory.

PowerFlex 6000T MV drives feature:

- Easy configuration, integration and visualization in the Studio 5000 design environment. The Add-on Profile is the preconfigured data translator, visual user interface, and data configurator all rolled into one. It is also the primary tool that sends drive data to the control system
- Connected Components Workbench software full device profile support. Easy to configure, program and visualize in a single multi-language software package
- Simplified and intuitive local control, monitoring and diagnostics with a 10-inch (254 mm) color touch screen HIM that supports multiple languages (Portuguese, Spanish, French, German, Chinese, Polish, Russian, etc.)
- Real-time alerts available for the device health via FactoryTalk® Analytics™ for Devices
- Extensive input power monitoring functionality for kW, kVA, kVAR, elapsed kWh, MWh and power factor
- Quick and secure flash-over-fiber firmware updates for all main control boards and power cells from a single file
- More comprehensive and faster troubleshooting with Forensic Data Recorder functionality
- TotalFORCE technology provides excellent motor control through precise, adaptive control of velocity and torque while using maintenance analytics alerts to ensure maximum drive and process uptime

PowerFlex 6000T medium voltage drives

are particularly well suited for all-purpose, non-regenerative applications such as fans, pumps, mills, conveyors and compressors. They are an ideal solution for motor control applications from 100...11,000 kW (150...15,000 Hp) and for motors rated from 2.3...11 kV.

Air-cooled PowerFlex 6000T drives are designed to maximize energy efficiency by enabling soft-starting and variable-speed control in normal-duty and heavy-duty applications.

To achieve low input harmonics and near-unity power factor, the drives use a Cascaded "H" Bridge topology. This topology combines an integrally mounted phase-shifting isolation transformer with series-connected power cells for each phase.

PowerFlex 6000T AC drives allow for flexibility in a variety of applications and are available in many configurations based on motor voltage.

- Multiple control modes, including flux vector control – featuring up to 150% starting torque with an encoder
- Simple, air cooled design at all voltage and power ratings
- Eco design main cooling fans provide higher efficiency and reduces losses
- Integrally mounted multi-pulse isolation transformer helps ensure low line-side harmonics
- Automatic power cell bypass helps minimize downtime in your critical applications
- Common modular power cells designed for easy removal, minimizing Mean Time To Repair



TotalFORCE technology

Similar to the technology in our low voltage drives portfolio, TotalFORCE technology for PowerFlex 6000T MV drives helps your application increase throughput, improve quality and reduce downtime.

Increase the throughput of your application

With excellent tracking, the drives follow speed or torque commands very closely. They also effectively reject disturbances when loads change suddenly to help keep the application running smoothly and increase output.

Improve the quality of end products

As a result of rapid processing speed, the drives are able to provide precise velocity and torque control to help improve the uniformity of end products. In addition, high torque accuracy helps maintain speed regulation in highly demanding tension control applications.

Reduce equipment downtime with predictive maintenance

PowerFlex 6000T drives continuously monitor operation, tracking the health of electrical components in the drive and motor to provide real-time diagnostic information to your control system. With this information, it is possible to predict equipment failures and take action to prevent unplanned downtime.

In addition, adaptive control features help isolate potentially harmful vibration and automatically compensate for variances to help keep your application up and running.

Compact PowerFlex design

- Available from 2.3 kV to 6.6 kV in three frame sizes – up to 70 A, 71...140 A and 141...215 A
- Rear access not required
- Top or bottom line/load cables
- Surge arrester option available without size increase
- IP31/IP42 and Type 3R/IP54 enclosures available
- 80 dB(A)
- Reduced commissioning time
- Minimum 100,000 hours Mean Time Between Failure
- Automatic power cell bypass option available without size increase
- Available with up to 13.8 kV input

PowerFlex 6000T drive synchronous transfer bypass

Synchronous transfer is used for controlled starting and speed control of multiple motors, with one drive. The drive can be used for soft-starting large motors to limit inrush current or for speed control of multiple motors, one at a time, as required by your operating conditions. Synchronous transfer helps to limit the mechanical wear and tear on the motor, which in turn prolongs the life of the motor. It also reduces the investment and operating costs for the user.

- Available from 2.3...11 kV
- Can start up to 10 motors on one drive, up to a maximum of 680 A for each motor (totaling up to 3000 A)
- Bumpless transfer
- Ideal for natural gas or oil pipeline applications

PowerFlex 6000T drive synchronous transfer system design architecture

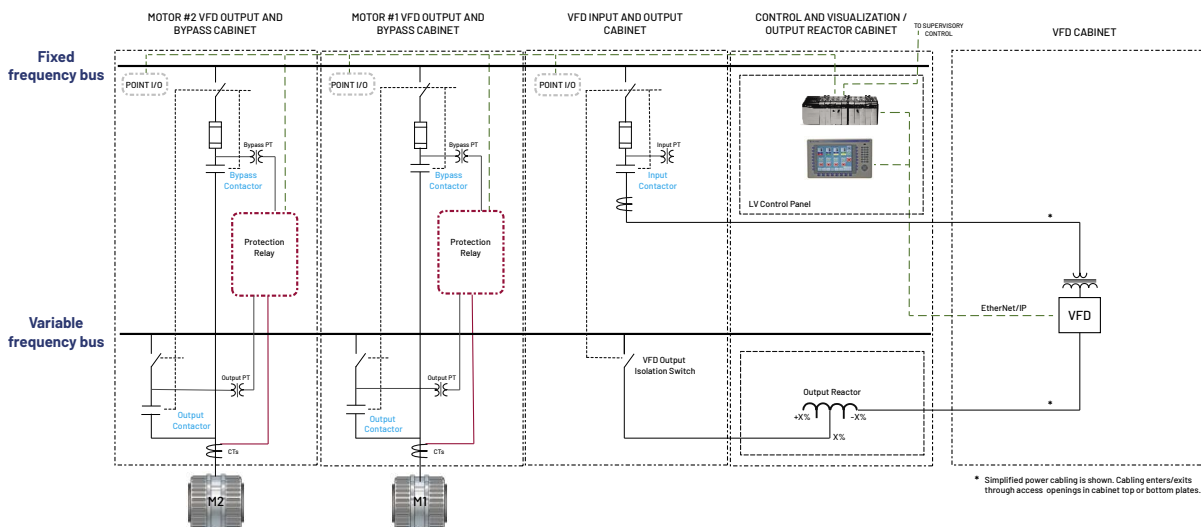

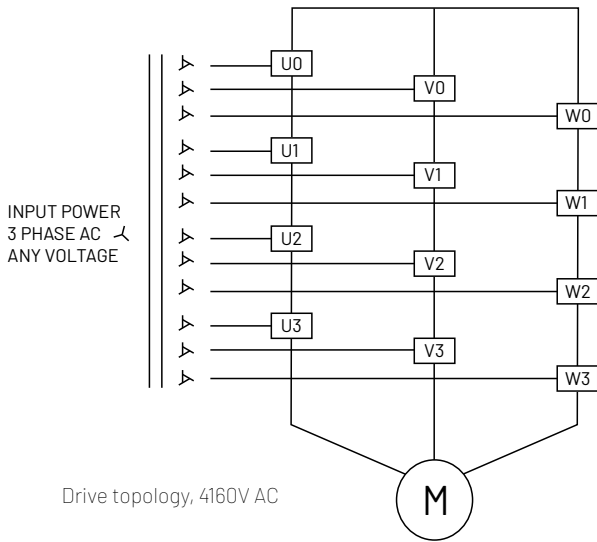

Automatic power cell bypass

In the unlikely event of a power cell failure, the automatic power cell bypass option allows the PowerFlex 6000T drive to bypass that power cell, along with the corresponding power cells in the other two phases, so that the drive will remain running at a reduced capacity, providing time to plan for a scheduled shut-down.

- Helps maximize uptime in your critical applications
- Solid-state bypass circuit reduces process interruption time

Cascaded "H" bridge (CHB) topology

The proven CHB topology combines an integrally mounted phase-shifting isolation transformer and series-connected power cells for each phase.

In addition to stepping down the input voltage, the isolation transformer also provides two other principal functions:

- Mitigate common mode voltage stress, so motors with standard insulation levels can be used
- Reduce total harmonic distortion, due to the phase shifting of its secondary windings, so input side harmonics don't negatively impact the plant or utility power grid

A number of identical low voltage power cells are series-connected (cascaded) together to produce the medium voltage levels required to operate the motor. The voltage step for each power cell is relatively small and a pulse width modulation switching pattern is used so output harmonics and torque pulsations at the motor are minimal, even at lower speeds. This technology allows standard motors to be used for new applications and it is ideal for retrofitting existing motors. This allows for longer motor cable lengths, without the requirement for output filtering.

This power cell concept makes maintenance quick and easy. Each power cell has built-in diagnostics to identify and isolate a cell needing replacement, in the unlikely event of a failure. This minimizes power cell replacement time, so process uptime is maximized. A number of system bypass options are also available.

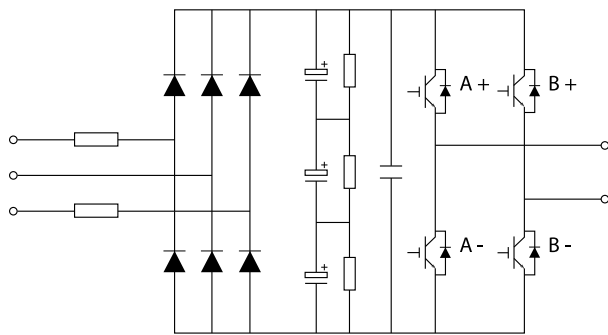

Standard power cell

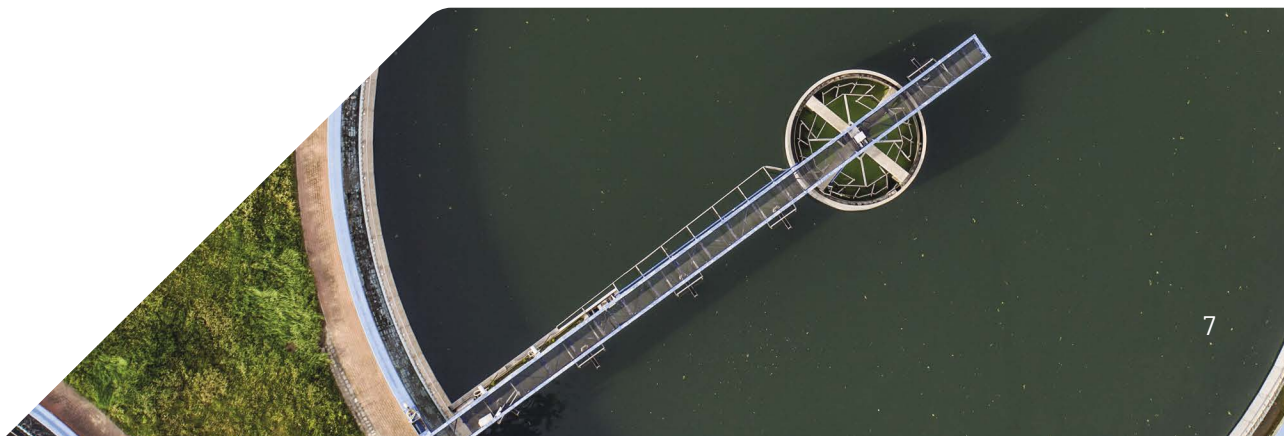

PowerFlex 6000T maximum power vs. voltage rating

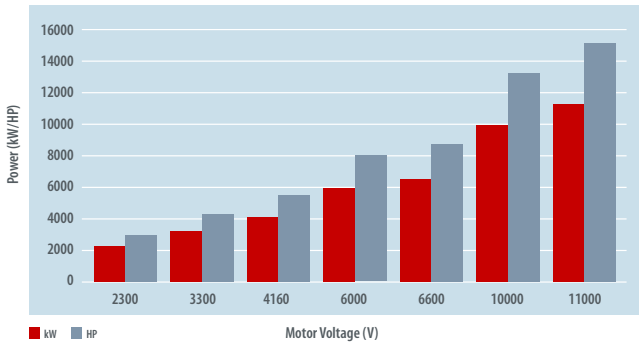

Line side waveforms

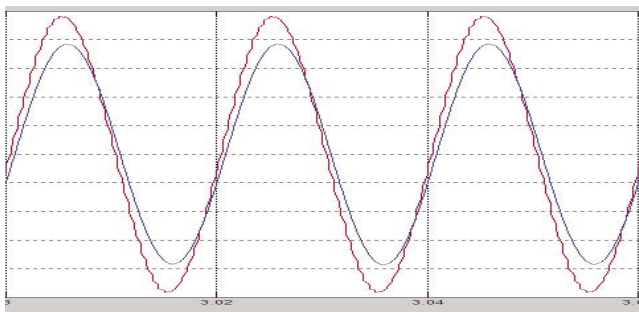

6.6 kV Input (36 Pulse) ■ Phase Current ■ Phase-to-Phase Voltage

Power system friendly input current and voltage waveforms comply with IEEE 519-2014 Harmonic Guidelines.

Motor waveforms

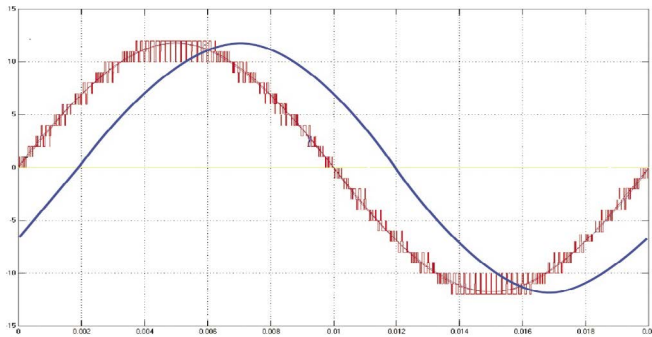

6.6 kV Output ■ U Phase Current ■ U-V Phase Voltage

Motor friendly current and voltage waveforms are suitable for operation with new or existing standard motors. Inverter duty motors not required.

Reduce input harmonics with the RealSine™ solution

With the optional RealSine solution, drive input harmonics are significantly reduced.

Available from 2.4...4.16 kV up to 215 A, without changing the number of drive transformer secondary windings, each secondary winding is specially phase-shifted to achieve 54 pulse or 72 pulse respectively, compared to traditional 18 pulse or 24 pulse designs for this voltage range.

This option does not require additional hardware or affect the drive footprint.

For 2400V, 3000/3300V or 4160V, the new design offers up to 30% improvement in input Total Harmonic Current Distortion (THDi). A cleaner spectrum improves the drive operational efficiency and makes it more sustainable to the environment.

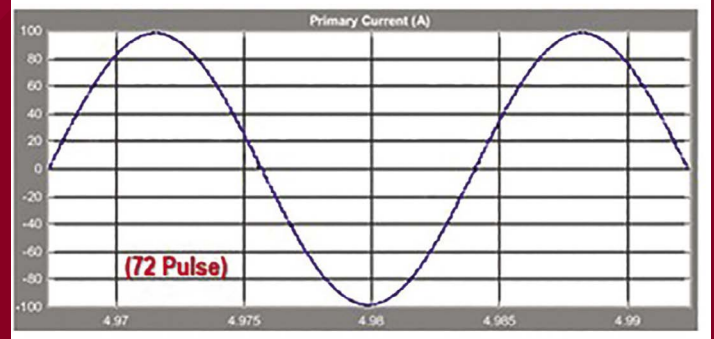
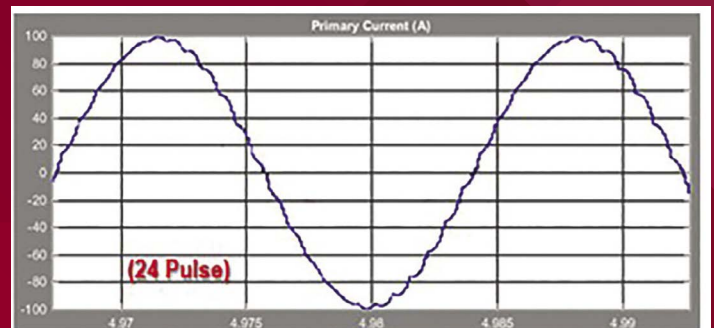

The comparison of primary current waveform between 24 pulse and 72 pulse.

PowerFlex 7000 AC drives

Efficient & integrated high-power performance

The PowerFlex 7000 family of medium voltage AC drives deliver flexibility and high-power performance in a single solution for motor control applications from 150...6300 kW (200...8500 Hp), rated 2.4...6.6 kV.

To help reduce energy costs and motor wear, PowerFlex 7000 drives enable soft-starting and variable-speed control of processes with high power demands. Our portfolio provides virtually perfect output current and voltage waveforms to allow the use of standard or existing motors and motor cables.

Thanks to advanced power semiconductor technology and a simple, straightforward design, the drive's component count is the lowest of any medium voltage drive available. The result? Increased reliability, less downtime and fewer spare parts. To achieve even more efficiency, choose a configuration with Direct-to-Drive™ technology – and connect a motor directly to the drive without an isolation transformer.

PowerFlex 7000 drives incorporate information and communication capabilities and an intuitive, easy-to-use, color touchscreen operator interface to monitor and control your processes – and optimize performance and maintenance.

The PowerFlex 7000 drive portfolio:

Air-cooled drives

For motors from 150...6000 kW (200...8000 Hp) at 2.4 kV to 6.6 kV. This drive offers different frame sizes and heat sink or heat pipe configurations to accommodate various power ranges.

Liquid-cooled drives

For motors from 2240...6340 kW (3000...8500 Hp*) at 4.16 kV to 6.6 kV, this option uses a closed-loop liquid-cooling system with liquid-to-air or liquid-to-liquid heat exchanger options and provides redundant pumps as standard, for optimal reliability.

Marine drives

With power ratings from 600...24,000 kW (800...32,000 Hp), these liquid-cooled marine drives use Direct-to-Drive technology to conserve space and weight and is built to withstand the rigors at sea.

Extended power configurations

Available up to 25,400 kW (34,000 Hp), these high power air-cooled and liquid-cooled drive modules are effective solutions for hot back-up and redundancy, Load Commutated Inverter retrofits and power upgrades.

CONTROL OPTIONS:

- Safe Torque Off
- High performance torque control with TorqProve™ technology
- Synchronous transfer

ENCLOSURE OPTIONS:

- ArcShield™ arc resistant enclosures
- IP42

* Ratings for single drive channel configuration

Control options

SAFE TORQUE OFF

Help save time and costs through decreased downtime, while helping to protect personnel and property from preventable accidents by increasing the functional safety of your system with Safe Torque Off. This feature is TÜV Certified and helps achieve requirements for SIL 3/PLe/IEC 61508/ISO 13849-1. This option is available for AFE PowerFlex 7000 drives.

HIGH PERFORMANCE TORQUE CONTROL

PowerFlex 7000 medium voltage AC drives now offer the option of zero speed holding torque control capabilities and TorqProve control. Ideal for applications such as hoists, drag lines, winches and test stands, the PowerFlex 7000 drive can now deliver 100% torque at zero speed. This control capability continuously helps to control torque around zero speed and provides a higher drive speed and torque response required for these applications. This option is available for AFE PowerFlex 7000 drives.



A drive system with ArcShield technology

Meeting safety standards with an effective design

The PowerFlex 7000 drive system with ArcShield technology is a fully integrated Allen-Bradley CENTERLINE® starter and PowerFlex 7000 drive combination. Standalone, fully integrated systems and systems that are designed to work with existing Allen-Bradley medium voltage starter lineups are available – providing either a 40 kA or 50 kA arc fault rating.

Designed to redirect the energy that is created from an arc flash event, out the top of the enclosure and away from personnel, Type 2B accessibility helps protect personnel while in front, at the side, or behind the enclosure in the event of an arcing fault. Additionally, Type 2B protection is maintained when the low voltage control door is open for maintenance purposes.

- 1 Pressure relief vents direct arc gases and material away from the front, rear and sides of the enclosure during an arc flash.
- 2 Gases and materials are vented up and out of the top of the enclosure through the plenum exhaust system.
- 3 Patented self-closing vent plates prevent arc flash gases from escaping through the fan exhaust vents.
- 4 Cabinet doors are reinforced with welded channels designed to maintain structural integrity during an arc flash.
- 5 Robust cabinet construction, including reinforced side sheets, doors, roof, and back plates are designed to increase rigidity to contain the arc fault energy.
- 6 High strength hinges, latches and bolts securely attach door to cabinet for added protection.
- 7 Patented self-closing vent plates prevent arc flash gases from escaping out through front air intake vents.



Fully integrated 50 kA rated PowerFlex 7000 drive system with ArcShield technology

The right expertise, at the right time.

We empower your lifecycle and digital transformation journey with our expansive domain knowledge.



CONSULTING SERVICES

Digital transformation & The Connected Enterprise

Data science & analytics

Enterprise technology

Automation FEED / FEL

Safety & risk management



PROFESSIONAL SERVICES

Main Automation Contractor (MAC)

Modernization & migration engineering

Program and project management & implementation

Global rollouts



CONNECTED SERVICES

OT networks & cybersecurity

Managed services

OT infrastructure as a service

Remote support

Predictive/prescriptive analytics



FIELD SERVICES

Asset repair, remanufacturing and management

Safety assessment and remediation

On-site technical support

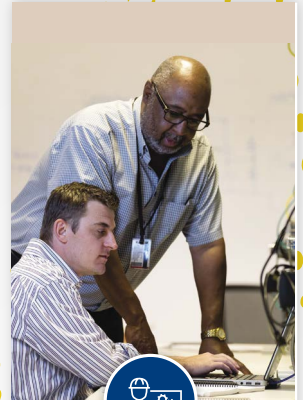

WORKFORCE SERVICES

E-learning

Instructor-led & virtual training





Workforce assessments

Virtual reality / augmented reality

For more information about how we can help you solve your unique business challenges, contact your local authorized Allen-Bradley distributor or Rockwell Automation sales office, or visit: rok.auto/services

Services vary by region.

Learn more about PowerFlex medium voltage drives at rockwellautomation.com

Connect with us.    

rockwellautomation.com

expanding **human possibility**[®]

AMERICAS: Rockwell Automation, 1201 South Second Street, Milwaukee, WI 53204-2496 USA, Tel: (1) 414.382.2000, Fax: (1) 414.382.4444

EUROPE/MIDDLE EAST/AFRICA: Rockwell Automation NV, Pegasus Park, De Kleetlaan 12a, 1831 Diegem, Belgium, Tel: (32) 2 663 0600, Fax: (32) 2 663 0640

ASIA PACIFIC: Rockwell Automation, Level 14, Core F, Cyberport 3, 100 Cyberport Road, Hong Kong, Tel: (852) 2887 4788, Fax: (852) 2508 1846

Allen-Bradley, ArcShield, CENTERLINE, Connected Components Workbench, Direct-to-Drive, expanding human possibility, FactoryTalk Analytics, PowerFlex, Studio 5000, TorqProve and TotalFORCE are trademarks of Rockwell Automation Inc. Trademarks not belonging to Rockwell Automation are property of their respective companies.

Publication PFLEX-BR010F-EN-P - October 2022 | Supersedes Publication PFLEX-BR010E-EN-P - June 2021

Copyright © 2022 Rockwell Automation, Inc. All Rights Reserved. Printed in USA.