

ISOMETER® IR420-D6

Offline monitor for de-energised AC, DC and 3(N)AC loads
in TN,TT and IT systems



ISOMETER® IR420-D6

Offline monitor for
de-energised AC, DC and 3(N)AC loads
in TN, TT and IT systems



ISOMETER® IR420-D6

Device features

- Insulation monitoring for de-energised TN, TT and unearthed systems AC, 3(N)AC and DC
- Nominal voltage extendable via coupling device
- Two separately adjustable response values 100 kΩ...10 MΩ
- LEDs: Power On LED, LEDs Alarm 1, Alarm 2 for signalling insulation faults
- Combined test/reset button
- Two separate alarm relays with one changeover contact each
- Fault memory behaviour, selectable
- Push-wire terminal (two terminals per connection)

Approvals



Product description

The "Offline monitor" ISOMETER® IR420-D6 monitors the insulation resistance of deenergized loads. These loads, e.g. fire pumps, slidevalves drives, elevator motors or emergency generators, either temporarily deenergized or deenergized for the most time, are applied from TN, TT or IT systems. The maximum permissible nominal voltage depends on the nominal contact voltage of the N/C contact of K3 (switch-on contactor).

The nominal voltage range can be extended with a coupling device. A low-impedance connection between the active conductors is necessary to correctly monitor the de-energised cables. An inductive star-point coupling device DS2-31 and an inductive load AG70 are available for the monitoring of de-energised lines. The maximum permissible system leakage capacitance C_e is 10 µF. Any other use than that described in this manual is regarded as improper.

Application

- De-energised loads such as automatic fire extinguisher pumps, emergency drives, ship cranes, slide-valve drives in supply lines (gas, water, oil), motor-driven closing systems, diving pumps, drives for anchors, elevators, flue-gas valves and emergency power generators

Function

When the insulation resistance between the system conductors and earth falls below the set response value, the alarm relays switch and the alarm LEDs light up. The measured value is indicated on the internal LC display. In this way any changes, for example when circuits are connected to the system, can be recognised easily. The fault memory can be reset by pressing the reset button. The device function can be tested using the test button. Two separately adjustable response values with one alarm relay each allow prewarning already in case of very high-resistance insulation faults. When the lower response level is reached, an interlocking function will be activated and the connection of a defective load can be prevented.

The insulation resistance is measured via the output L1 or via a contact to the system being monitored. The contact is controlled via the external contact element K3. With the contact in closed position, the system is de-energised and the insulation resistance is being measured. If the system or load is in operation, K3 opens the contact and insulation monitoring is deactivated. Make sure that the main switch disconnects all poles. To ensure that the measuring voltage can be superimposed onto the system, a low-resistance connection must exist between all line conductors (e.g. by motor windings).

Note: If the IR420-D6 is operated via a coupling device, the auxiliary contact (N/C contact) of K3 between the ISOMETER® and the coupling device need not to be designed for the nominal voltage of the system. A rated contact voltage of AC 230 V will be sufficient here.

Measurement method



Superimposed DC voltage with inverter.

Standards

The ISOMETER® of the IR420 D6 series complies with the requirements of the device standards:

- DIN EN 61557-8 (VDE 0413-8)
- EN 61557-8
- EC 61557-8
- EC 61326-2-4
- DIN EN 60664-1 (VDE 0110-1)
- DIN EN 60664-3 (VDE 0110-3)

Ordering information

Supply voltage ¹⁾ U _s		Type	Art. No.	
AC	DC		Screw-type terminal	Push-wire terminal
16...72 V, 42...460 Hz	9.6...94 V	IR420-D6-1	B91016415	B71016415
70...300 V, 42...460 Hz	70...300 V	IR420-D6-2	B91016407	B71016407
		IR420-D64-2	B91016408	B71016408

¹⁾ Absolute values

Accessories

Description	Art. No.
Mounting clip for screw mounting (1 piece per device)	B98060008

Suitable system components

Description	Nominal voltage U _n ¹⁾	Type	Art. No.
Coupling device	AC 0...1150 V, DC 0...1100 V	AGH150W	B915576
	AC 0...1650 V AC + DC 0...1300 V	AGH204S-4	B914013
	AC 50...400 Hz, 0...7200 V	AGH520S	B913033
	AC 230 V; 50 Hz	AG70	B984718
	3 AC 50...400 Hz, 0...500 V	DS2-31	B984092

¹⁾ Absolute values

Operating elements

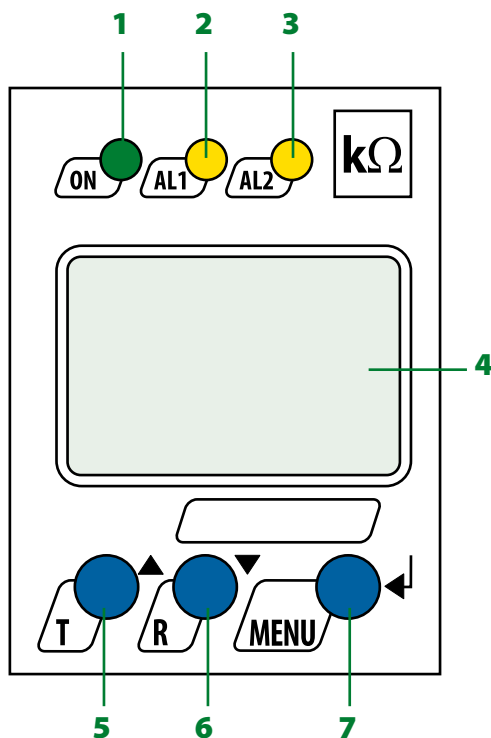

- 1 - Power On LED "ON", flashes in case of interruption of the connecting leads E/KE
- 2 - Alarm LED "AL1", lights when the value falls below the set response value Alarm 1 and flashes in case of interruption of the connecting leads E/KE
- 3 - Alarm LED "AL2", lights when the value falls below the set response value Alarm 2 and flashes in case of interruption of the connecting leads E/KE
- 4 - LC display
- 5 - Test button "T": to call up the self test.
Arrow up button: parameter change, to move up in the menu
- 6 - Reset button "R": to delete stored insulation fault alarms
parameter change, to move down in the menu
- 7 - "MENU" button: to call up the menu system.
Enter button: to confirm parameter changes

Wiring diagrams (examples)

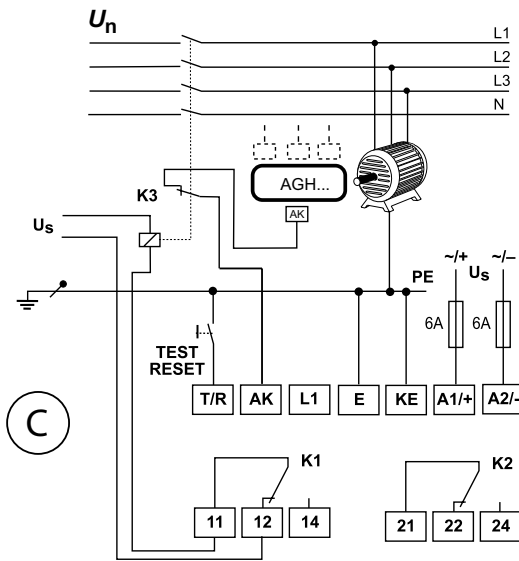
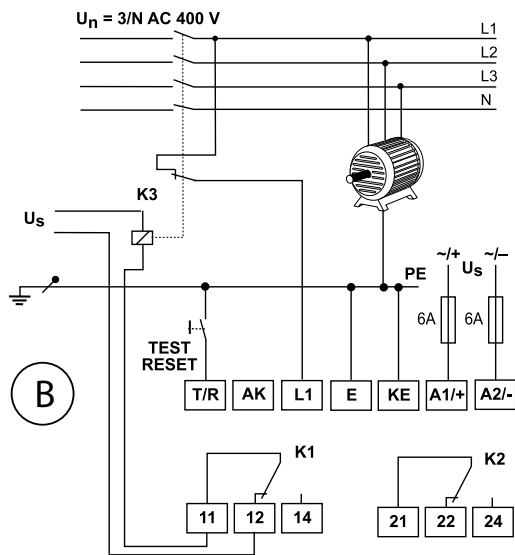
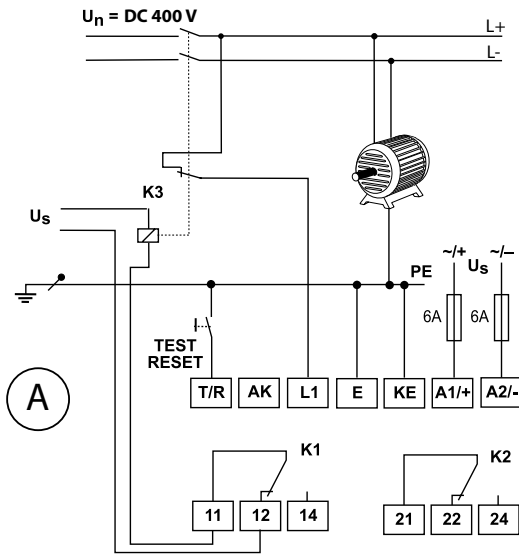

U_n AC 0...1150 V DC 0...1100 V	U_n AC 0...1650 V AC + DC 0...1300 V	U_n AC 3(N)AC 0...7,2 kV
L1 L2 L1 L2 AGH150W AK80 AK	L1 L2 L3 U3 V3 W3 AGH204S-4 AK80 AK	L1 2 5 4 3 AK PE PE

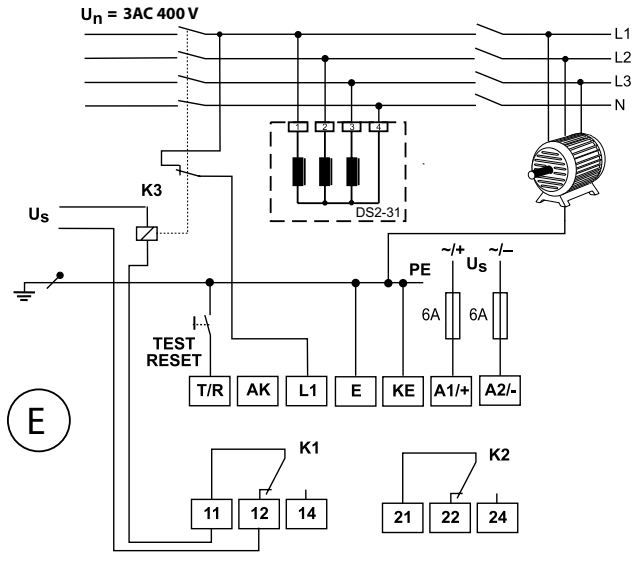
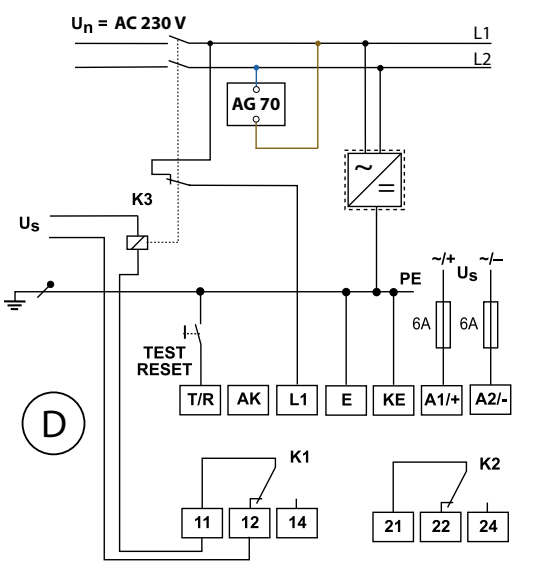

Description	
(A)	Monitoring of disconnected DC loads up to 400 V with a low-resistance connection between L + and L- via the load.
(B)	Monitoring of disconnected 3-phase AC loads up to 400 V with a low-resistance connection between L1, L2 and L3 via the load.
(C)	Monitoring of disconnected AC loads up to U_n with a low-resistance connection between L1, L2, and L3 via the load.
(D)	Monitoring of disconnected lines or disconnected loads with high resistance between the active conductors L1 and L2. The inductive load AG70 connects the lines L1 and L2 via an inductance so that both lines can be monitored.
(E)	Monitoring of disconnected lines or disconnected loads with high resistance between the active conductors L1, L2 and L3. The inductive star-point coupling device DS2-31 connects lines L1, L2 and L3 via an inductance so that four lines can be monitored.

Terminal	Connection
E, KE	Connect the leads E and KE separately to PE
A1, A2	Supply voltage U_s (see nameplate) via 6 A fuse
11, 12, 14	Alarm relay K1
21, 22, 23	Alarm relay K2 (system fault relay)
K3	relay for isolating the ISOMETER®
AGH...	Coupling device for the monitoring of loads up to U_n
AG70 DS2-31	For the monitoring of loads with an undefined internal resistance or an open single conductor in cables
T/R	for combined external test/reset button
L1, AK	Connection to the system being monitored

Technical data

Insulation coordination acc. to IEC 60664-1/IEC 60664-3

Rated insulation voltage	
(A1, A2) - (11, 12, 14) - (21, 22, 24)	300 V
(L1, AK, E, KE, T/R)	500 V
Rated impulse voltage	6 kV
Overvoltage category	II
Pollution degree	3
Protective separation (reinforced insulation) between:	
(A1, A2) - (L1, AK, E, KE, T/R) - (11, 12, 14) - (21, 22, 24)	
Voltage test acc. IEC 61010-1	2.2 kV

Supply voltage

IR420-D6-1:

Supply voltage U_s	AC 16...72 V/DC 9.6...94 V
Frequency range U_s	42...460 Hz/DC

IR420-D6-2:

Supply voltage U_s	AC/DC 70...300 V
Frequency range U_s	42...460 Hz, DC
Power consumption	≤ 3 VA

System being monitored

Nominal system voltage U_n	AC 0...400 V
Tolerance of U_n	25 %
Frequency range of U_n	42...460 Hz
without AGH nominal contact voltage of the N/C. contact K3 (switch-on contactor)	
with AGH520S	AC 50...400 Hz, 0...7200 V
with AGH150W	AC 0...1150 V
	DC 0...1100 V
with AGH204S-4	AC 0...1650 V
including DC components	0...1300 V

Response values

Response value R_{an1} (AL 1)	100 kΩ...10 MΩ (1 MΩ)*
Response value R_{an2} (AL 2)	100 kΩ...10 MΩ (100 kΩ)*
Operating error (≤ 1 MΩ)	±15 %
Hysteresis	+25 %

Time response

Response time t_{an} at $R_F = 0,5 \times R_{an}$ and $C_e = 1 \mu F$	≤ 4 s
Start-up delay t	0...10 s (0 s)*
Response delay t_{on}	0...99 s (0 s)*

Measuring circuit

Measuring voltage U_m	+12 V
Measuring current I_m ($R_F = 0 \Omega$)	≤ 10 μA
Internal d.c. resistance R_i	≥ 1.2 MΩ
Internal impedance Z_i (50 Hz)	≥ 1.1 MΩ
Admissible extraneous d.c. voltage U_{fg}	≤ DC 300 V
System leakage capacitance C_e	≤ 10 μF

Displays, memory

Display	LC display, multi-functional, non-illuminated
Display range, measuring value	10 kΩ...20 MΩ
Percentage operating error (≤ 1 MΩ)	±15 %
Password	off/0...999 (off)*
Fault memory (alarm relay)	on/off (off)*

Inputs

Cable length external test/reset button	≤ 10 m
---	--------

Switching elements

Number of	2 (changeover contacts K1, K2)
Operating principle	N/O operation, N/C operation (N/O operation n.o.)*
Electrical endurance	10000 switching operations

Contact data according IEC 60947-5-1

Utilization category	AC-13	AC-14	DC-12	DC-12	DC-12
Rated operational voltage	230 V	230 V	220 V	110 V	24 V
Rated operational current	5 A	3 A	0.1 A	0.2 A	1 A
Minimum current	1 mA at AC/DC ≥ 10 V				

Technical data (continuation)

Environment/EMC

EMC	acc. to IEC 61326
Operating temperature	-25...+55 °C

Climatic classes acc. to IEC 60721 (without condensation and formation of ice)

Stationary use (IEC 60721-3-3)	3K24
Transport (IEC 60721-3-2)	2K11
Storage (IEC 60721-3-1)	1K22

Classification of mechanical conditions acc. to IEC 60721:

Stationary use (IEC 60721-3-3)	3M11
Transport (IEC 60721-3-2)	2M4
Storage (IEC 60721-3-1)	1M12

Connection

Connection	screw terminals
Connection properties	
rigid	0.2...4 mm ² (AWG 24...12)
flexible	0.2...2.5 mm ² (AWG 24...14)
Two conductors with the same cross section	
rigid/flexible	0.2...1.5 mm ² (AWG 24...16)
Stripping length	8 mm
Tightening torque, terminal screws	0.5...0.6 Nm

Connection

Connection properties	push-wire terminals
rigid	0.2...2.5 mm ² (AWG 24...14)
flexible	
without ferrules	0.75...2.5 mm ² (AWG 19...14)
with ferrules	0.2...1.5 mm ² (AWG 24...16)
Stripping length	10 mm
Opening force	50 N
Test opening, diameter	2.1 mm

Other details

Operating mode	continuous
Position	any position
Degree of protection internal components (EN 60529)	IP30
Degree of protection terminals (EN 60529)	IP20
Enclosure material	polycarbonat
Flammability class	UL94 V-0
DIN rail mounting acc. to	IEC 60715
Screw mounting	2 x M4 with mounting clip
Documentation number	D00117
Weight	approx. 150 g

(*) = Factory setting

Dimension diagram XM420

Dimensions in mm

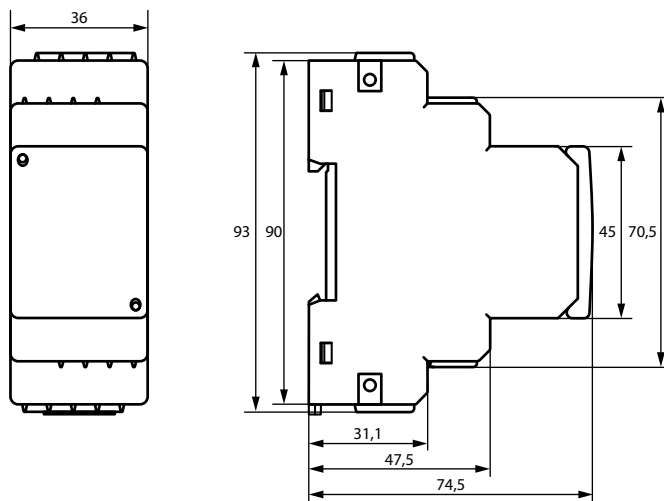

Bender GmbH & Co. KG

Londorfer Straße 65 • 35305 Grünberg • Germany
Tel.: +49 6401 807-0 • info@bender.de • www.bender.de



BENDER Group