

INVERTEC® 275S

Spare Parts.....	1
Figure A: Machine Assembly	1
Figure B: Front items.....	2
Figure C: Inside Machine Items	3
Figure D: Rear items.....	4
Figure E: Cover.....	4
Electrical Schematic	5
CODE: 50535.....	5



Spare Parts

SP50535 REV03
10/2022

ASSEMBLY PAGE NAME			Machine Assembly	Front Items	Inside Machine Items	Rear Items	Cover	
CODE NO.:	K NO.:	FIGURE NO.:	A	B	F	D	E	
50535	K14242-1	INVERTEC® 275S	1	1	1	1	1	

*items highlighted in bold are recommended spare parts

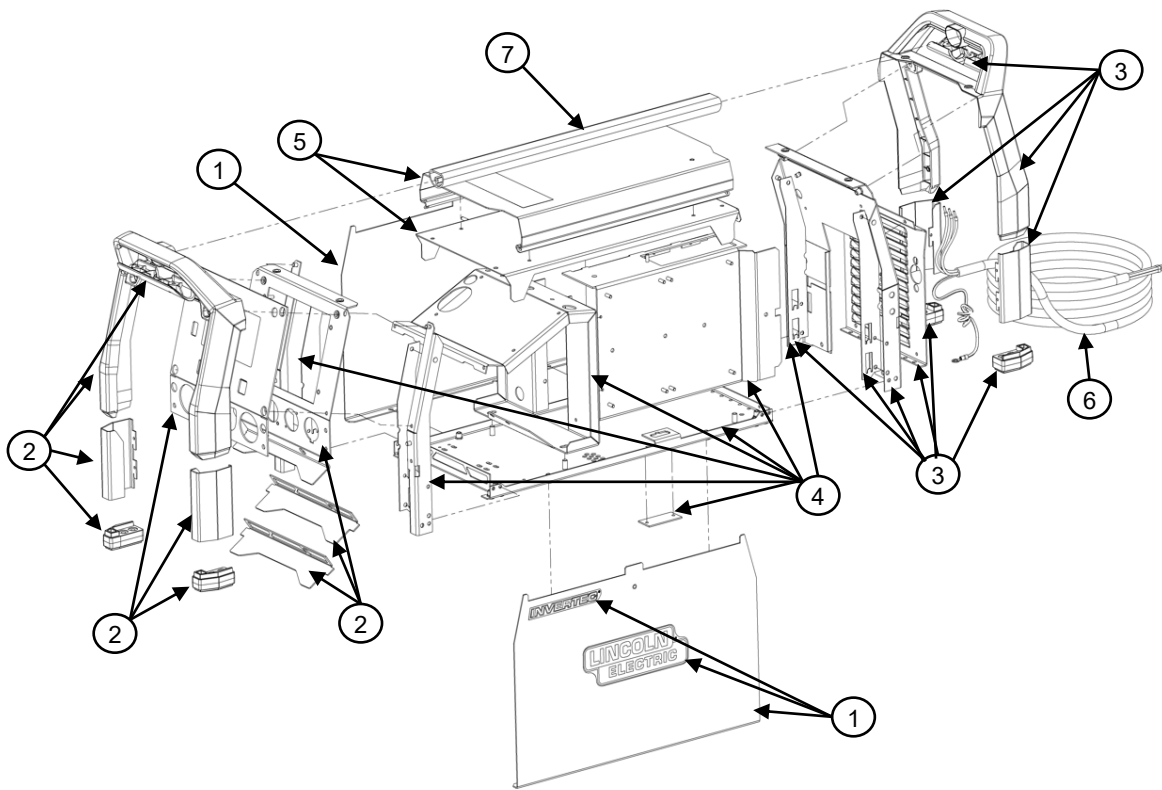

Figure A

Figure A: Machine Assembly

Item	Description	Part Number	QTY	1	2	3	4	5	6	7
1	SIDES PANEL	T-8040-134-1R	1	X						
	LE LOGO		2							
	INVERTEC STICKERS		2							
	SIDE PANEL		2							
2	FRONT	T-8040-154-1R	1	X						
	FOOT RIGHT		1							
	FOOT LEFT		1							
	CORNER FRONT RIGHT		1							
	CORNER FRONT LEFT		1							
	PLASTIC FRAME		1							
	RED CAP		1							
	FRONT POLYCARBONATE		1							
	FRONT PANEL		1							
	METAL LOUVERS		2							
3	REAR	T-8040-136-1R	1	X						
	CORNER REAR LEFT		1							
	CORNER REAR RIGHT		1							
	PLASTIC FRAME		1							
	RED CAP		1							
	BACK PANEL		1							
	BACK LOUVERS		1							
	FOOT RIGHT		1							
	FOOT LEFT		1							
	CRUTCH		2							
4	BASE, PARTITION	T-8040-137-1R	1	X						
	BOTTOM ASSEMBLY		1							
	TRANSFORMER BRACKET		1							
	FOAM		0,64							
	INVERTER BRACKET		1							
	BRIDGE BRACKET		1							
	RIGHT LEG ASSEMBLY		1							
	COOLER PLUG PATCH		1							
	LEFT LEG ASSEMBLY		1							
	CRUTCH		2							
5	COVER	T-8040-138-1R	1	X						
	STICKER CAUTION		1							
	ROOF ASSEMBLY		1							
	ROOF BRACKET		1							
6	MAIN INPUT CORD	R-5241-245-1R	1	X						
7	HANDLE	W92X0228-4R	1	X						

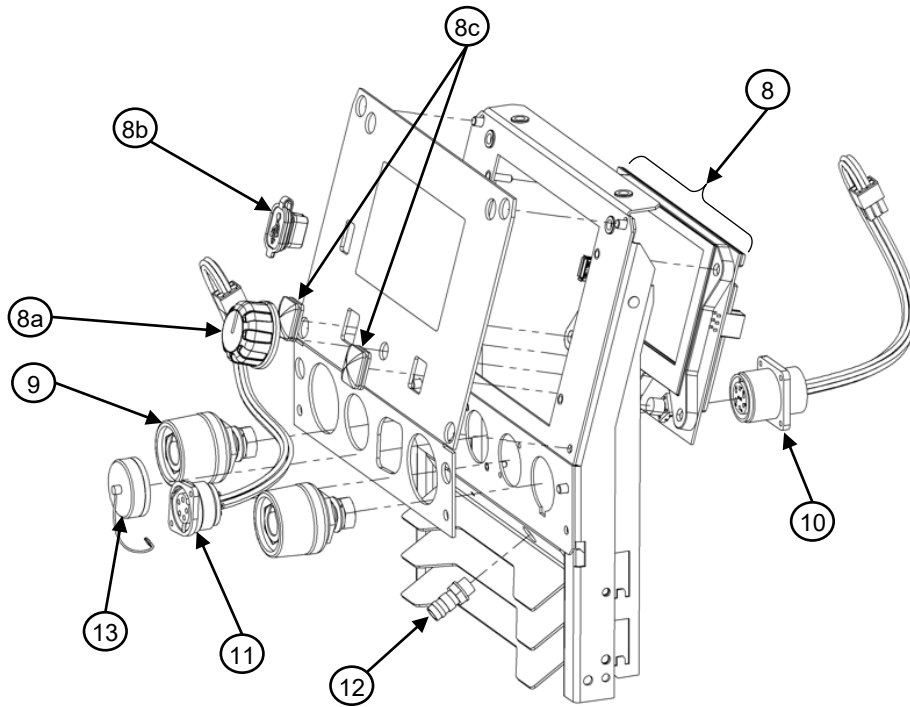

Figure B

Figure B: Front items

Item	Description	Part Number	QTY	1	2	3	4	5	6	7
8	SCREEN & BOARDS	T-8040-139-1R	1	X						
	TFT DISPLAY		1							
	SCREEN BRACKET		1							
	TFT FRONT PANEL BOARD		1							
	SoM BOARD		1							
	SCREW M3x10		6							
	WASHER M3 SPRING LOCK		2							
	DISPLAY FOAM		1							
8a	KNOB	9SM22778-2	1	X						
8b	USB CAP	R-0010-804-1R	1	X						
8c	BUTTON COVER	9SS23055	2	X						
9	POWER PLUG	W7690350R	2	X						
10	REMOTE CONTROL SOCKET + HARNESS	R-5241-247-1R	1	X						
11	C5B SOCKET + HARNESS	R-5241-247-2R	1							
12	GAZ PLUG	W8800082R	1							
13	SOCKET COVER	1158-641-128R	1	X						

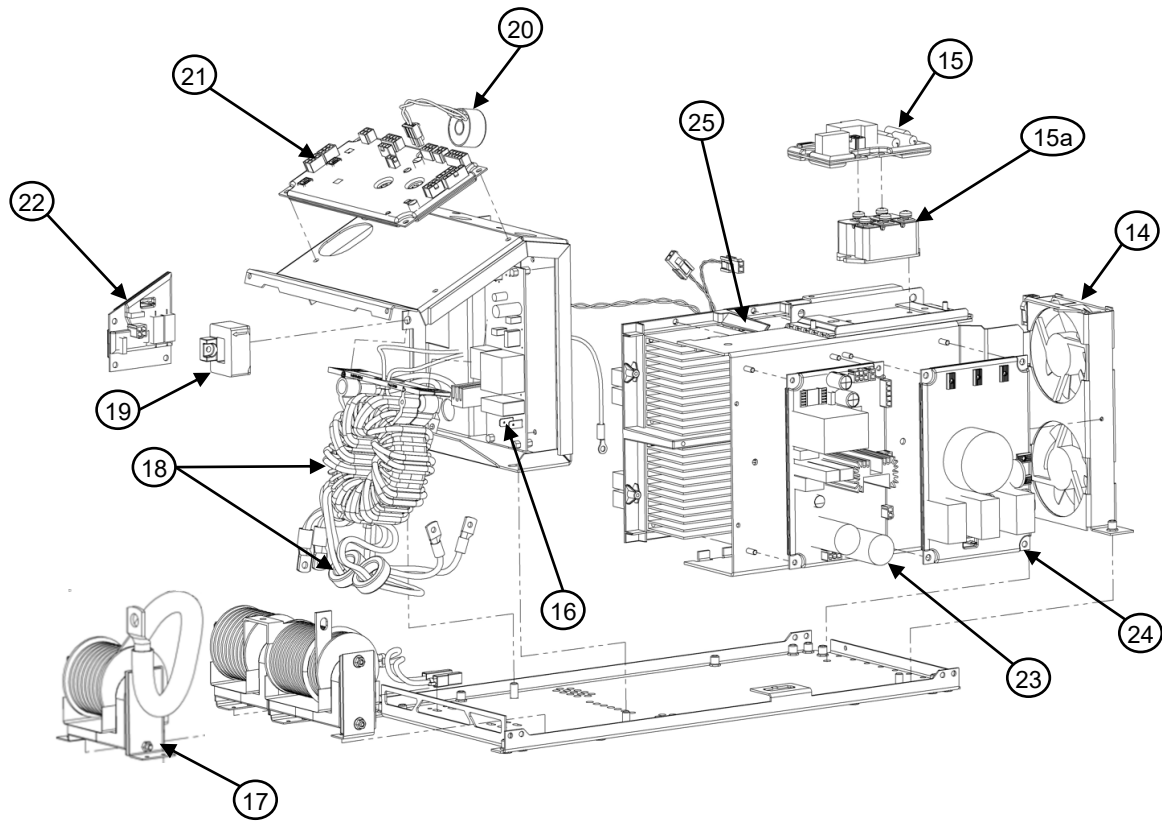

Figure C

Figure C: Inside Machine Items

Item	Description	Part Number	QTY	1	2	3	4	5	6	7
14	FANS EQUIPEMENT	T-8040-140-1R	1	X						
	FANS BRACKET		1							
	FANS		1							
15	PRELOAD BOARD	R-6042-108-1R	1	X						
15a	RECTIFIER BRIDGE	90002327PR	1	X						
16	HF BOARD	W05X1615R	1							
17	CHOKE	R-0010-802-1R	1	X						
18	TRANSFORMER	T-8040-141-1R	1	X						
	TRANSFORMER		1							
	FERRITE		2							
	TIE		2							
19	300A CURRENT SENSOR	1157-769-157R	1	X						
20	PRIMARY CURRENT SENSOR	R-8240-042-1R	1	X						
21	COMMAND BOARD	R-6042-105-1R	1	X						
22	SECONDARY FILTER BOARD	R-6042-110-1R	1	X						
23	AUXILARY BOARD	R-6042-107-1R	1	X						
24	EMC BOARD	R-6042-104-1R	1	X						
25	INVERTER	R-6042-101-1R	1	X						

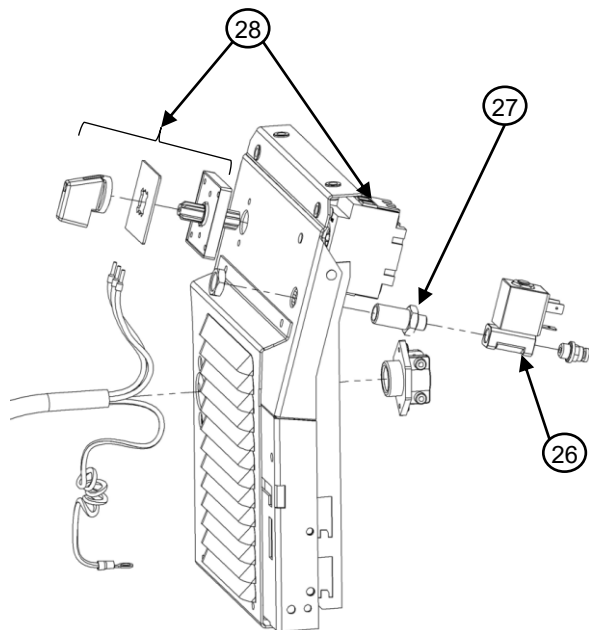

Figure D

Figure D: Rear items

Item	Description	Part Number	QTY	1	2	3	4	5	6	7
26	ELECTROVALVE EV 24V	W000227800	1							
27	INLET GAS CONNECTOR 1/4 - 1/8	W8896074R	1							
28	SWITCH	1115-260-225R	1	X						

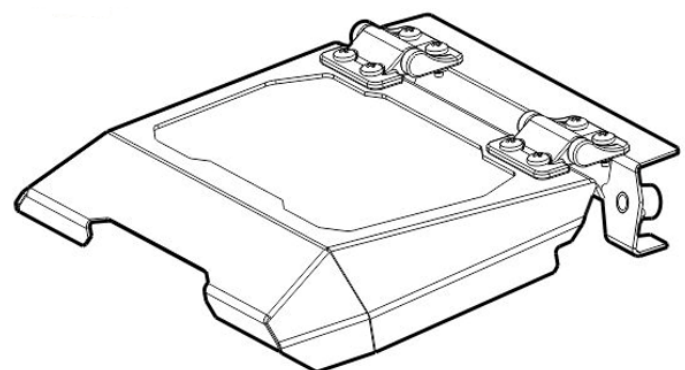

Figure E

Figure E: Cover

Item	Description	Part Number	QTY	1	2	3	4	5	6	7
29	Cover	R-8240-050-1R	1	X						

Electrical Schematic

CODE: 50535

