

# Compression Load Cells

## >Model CX, CX77

CX : Painted finished steel.  
CX77, CXH : Nikel planted steel

High Precision Accuracy Compression Service.  
Hopper, Tank Weighing.  
Protection Class IP67 (CXG, CXM)

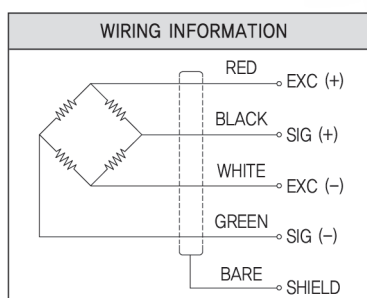
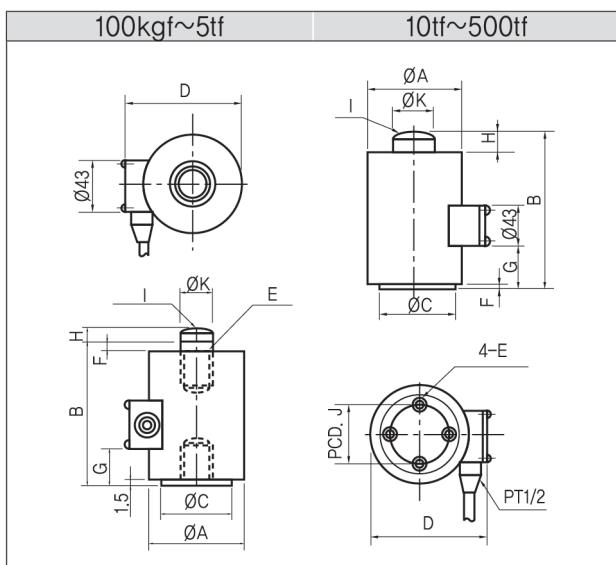
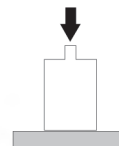

## >SPECIFICATIONS

Specifications	Accuracy		
	CXH	CXM	CXG, CX77
Rated capacity(R.C)	1tf, 2tf, 3tf, 5tf, 10tf, 20tf	100kgf, 200kgf, 500kgf, 1tf, 2tf, 3tf, 5tf, 10tf, 20tf, 30tf, 50tf, 100tf, 200tf, 300tf, 500tf	
Rated output(R.O)	2.0mV/V±0.1%	2.0mV/V±0.1(50tf~500tf : 1.5mV/V±0.1%)	
Nonlinearity	0.02% of R.O.	0.05% of R.O.	0.1% of R.O. (200, 300, 500tf : 0.5% of R.O.)
Hysteresis	0.02% of R.O.	0.05% of R.O.	0.1% of R.O. (200, 300, 500tf : 0.5% of R.O.)
Repeatability	0.02% of R.O.	0.05% of R.O.	0.1% of R.O.
Zero balance	±1% of R.O.	±1% of R.O.	±1% of R.O.
Temperature effect on rated output	0.03% of LOAD/10°C	0.03% of LOAD/10°C	0.1% of LOAD/10°C
Temperature effect on zero balance	0.03% of R.O./10°C	0.03% of R.O./10°C	0.1% of R.O./10°C
Temperature range, compensated	-10~60°C	-10~60°C	-10~60°C
Temperature range, safe	-20~80°C	-20~80°C	-20~80°C
Terminal resistance, input	350±5Ω	350±5Ω	350±5Ω
Terminal resistance, output	350±5Ω	350±5Ω	350±5Ω
Insulation resistance bridge/case	5000MΩ	5000MΩ	5000MΩ
Excitation recommended	10V	10V	10V
Safe overload	150% R.C.	150% R.C.	150% R.C.
Cable length	Ø7mm 4core, 3m	Ø7mm 4core, 3m	Ø7mm 4core, 3m

## >DIMENSIONS TABLE

unit:mm

Model	Capacity	ØA	B	ØC	D	E	F	G	H	RI	J	ØK	Weight
CX	100kgf~1tf (490.3N~9.807kN)	88	107	50	118	M12×1.25 DP15	4	25	9	25	-	24	3kg
	2tf (19.61kN)	88	150	66	118	M24×2 DP30	5	42	20	60	-	42	4.5kg
	3tf (29.42kN)	88	150	66	118	M24×2 DP30	5	42	20	60	-	42	4.5kg
	5tf (49.03kN)	88	150	66	118	M24×2 DP30	5	42	20	60	-	42	4.5kg
	10tf (98.07kN)	93	127	80	129	M12×1.75 DP20	2	42	15	140	60	38	5kg
	20tf (196.1kN)	93	147	80	129	M12×1.75 DP20	2	50	15	140	60	38	5.5kg
	30tf (294.2kN)	93	147	80	129	M12×1.75 DP20	2	50	15	140	60	38	5.5kg
	50tf (490.3kN)	137	165	110	170	M12×1.75 DP20	2	75	20	180	80	50	10kg
	100tf (980.7kN)	166	210	140	198	M16×2 DP20	2	100	20	200	100	70	28kg
	200tf (1.961MN)	216	250	180	246	M16×2 DP25	2	120	30	300	130	95	45kg
	300tf (2.942MN)	216	320	180	246	M24×3 DP35	2	160	30	600	130	120	50kg
500tf (4.903MN)	256	400	238	283	M30×3.5 DP50	7	200	20	800	200	170	65kg	
1000tf (9.807MN)	295	385	270	247	M24×3 DP35	5	170	25	800	200	220	140kg	
CX77	200tf (1.961MN)	164	220	140	194	M20×2.5 DP30	5	80	20	600	100	95	29kg
	300tf (2.942MN)	164	250	140	194	M24×3 DP35	5	94	20	600	100	95	30kg
	500tf (4.903MN)	217	270	170	247	M24×3 DP35	7	125	25	600	130	120	55kg

★Specifications are subject to change without notice.