

# Multi-Channel Process Monitor User Manual



Please fill out the form(s) below for each instrument that has been purchased.

Use this information when contacting Michell Instruments for service purposes.

Product Name	
Order Code	
Serial Number	
Invoice Date	
Installation Location	
Tag Number	

Product Name	
Order Code	
Serial Number	
Invoice Date	
Installation Location	
Tag Number	

Product Name	
Order Code	
Serial Number	
Invoice Date	
Installation Location	
Tag Number	



## Multi-Channel Process Monitor

For Michell Instruments' contact information please go to  
[www.ProcessSensing.com](http://www.ProcessSensing.com)

© 2023 Michell Instruments

This document is the property of Michell Instruments Ltd and may not be copied or otherwise reproduced, communicated in any way to third parties, nor stored in any Data Processing System without the express written authorization of Michell Instruments Ltd.

---

## Contents

Safety .....	vi
Electrical Safety .....	vii
Pressure Safety .....	vii
Hazardous Materials (WEEE, RoHS3 & REACH) .....	vii
Repair and Maintenance .....	vii
Calibration .....	vii
Safety Conformity .....	vii
Abbreviations .....	viii
<b>1 INTRODUCTION .....</b>	<b>1</b>
1.1 Performance Features .....	2
1.2 Applications .....	2
1.3 Flexible Configuration Options .....	3
1.4 System Components .....	4
1.4.1 Input/Output Signal .....	5
1.5 Sampling System .....	5
<b>2 INSTALLATION .....</b>	<b>6</b>
2.1 Unpacking the System .....	6
2.2 Environmental Requirements .....	7
2.3 Process Monitor Installation .....	7
2.4 Wiring .....	9
2.4.1 Overall Wiring Arrangement .....	9
2.4.2 Process Monitor Wiring .....	10
2.4.2.1 Power Supply Input Connection .....	11
2.4.2.2 Sensor Signal Input Connection .....	13
2.4.2.3 Analog Output Connection .....	14
2.4.2.4 Alarm Connection .....	15
2.4.2.5 RS485 Port Connection .....	15
2.4.3 Sensor Assembly Wiring .....	15
<b>3 OPERATION .....</b>	<b>16</b>
3.1 Main Screen .....	16
3.2 System Setup .....	17
3.2.1 Date/Time .....	17
3.2.2 Logging .....	18
3.2.3 Communications .....	19
3.2.4 System Alarm .....	19
3.2.5 Channel Type .....	20
3.2.6 About .....	20
3.3 Channel Menu .....	21
3.3.1 Liquid Channel .....	21
3.3.1.1 Liquid Channel: Outputs .....	22
3.3.1.2 Liquid Channel: Inputs .....	22
3.3.1.3 Liquid Channel: Alarms .....	23
3.3.1.4 Liquid Channel: Units .....	23
3.3.1.5 Liquid Channel: Displayed Parameters .....	24
3.3.1.6 Liquid Channel: Liquid Menu .....	25
3.3.1.7 Liquid Channel: User Liquids .....	26
3.3.2 Gas Channel .....	26
3.3.2.1 Gas Channel: Outputs .....	27
3.3.2.2 Gas Channel: Inputs .....	27
3.3.2.3 Gas Channel: Alarms .....	28
3.3.2.4 Gas Channel: Units .....	29
3.3.2.5 Gas Channel: Displayed Parameters .....	29

3.3.3	Oxygen Channel.....	30
3.3.3.1	Oxygen Channel: Outputs.....	30
3.3.3.2	Oxygen Channel: Inputs.....	31
3.3.3.3	Oxygen Channel: Alarms.....	31
3.3.3.4	Oxygen Channel: Units.....	32

## Figures

Figure 1	Multi-Channel Process Monitor (MCPM).....	1
Figure 2	Major Components of the MCPM.....	4
Figure 3	Dimensions of the Process Monitor (in mm).....	7
Figure 4	Rack Mounting Method.....	8
Figure 5	Overall Wiring Arrangement.....	9
Figure 6	MCPM Electrical Connections.....	10
Figure 7	POWER INPUT Connector Block.....	11
Figure 8	SENSOR INPUTS Connector Block.....	13
Figure 9	SENSOR OUTPUTS Connector Block.....	14
Figure 10	6-Channel Version.....	16
Figure 11	4-Channel Version.....	16
Figure 12	System Setup Menu.....	17
Figure 13	Date/Time Screen.....	17
Figure 14	Logging Screen.....	18
Figure 15	Communications Screen.....	19
Figure 16	System Alarm Screen.....	19
Figure 17	Channel Type Screen.....	20
Figure 18	About Screen.....	20
Figure 19	Channel Type Screen.....	21
Figure 20	Liquid Channel Setup Screen.....	21
Figure 21	Outputs Screen for the Liquid Channel.....	22
Figure 22	Inputs Screen for the Liquid Channel.....	22
Figure 23	Alarms Screen for the Liquid Channel.....	23
Figure 24	Units Screen for the Liquid Channel.....	23
Figure 25	Displayed Parameters Screen for the Liquid Channel.....	24
Figure 26	Liquid Menu Screen for the Liquid Channel.....	25
Figure 27	User Liquids for the Liquid Channel.....	26
Figure 28	Gas Channel Setup Screen.....	26
Figure 29	Outputs Screen for the Gas Channel.....	27
Figure 30	Inputs Screen for the Gas Channel.....	27
Figure 31	Alarms Screen for the Gas Channel.....	28
Figure 32	Units Screen for the Liquid Channel.....	29
Figure 33	Displayed Parameters Screen for the Gas Channel.....	29
Figure 34	Oxygen Channel Setup Screen.....	30
Figure 35	Outputs Screen for the Oxygen Channel.....	30
Figure 36	Inputs Screen for the Oxygen Channel.....	31
Figure 37	Alarms Screen for the Oxygen Channel.....	31
Figure 38	Units Screen for the Oxygen Channel.....	32
Figure 39	Dimensional Drawings (in mm).....	34

## Appendices

Appendix A	Technical Specifications.....	35
A.1	Dimensional Drawings.....	35
Appendix B	Modbus RTU and TCP Communications.....	37
Appendix C	Quality, Recycling, Compliance & Warranty Information.....	54
Appendix D	Return Document & Decontamination Declaration.....	56

## Safety

The instrument is designed to be completely safe when installed and operated correctly in accordance with the information provided in this manual.

This manual contains all the required information to install, operate and maintain this product. Prior to installation and use of this product, this entire manual should be read and understood. Installation and operation of this product should be carried out by suitably competent personnel only. The installation and operation of this product must be in accordance with the instructions provided and according to the terms of any associated safety certificates. Incorrect installation and use of this product other than those described in this manual and other than its intended purpose will render all warranties void.

This product meets the essential protection requirements of the relevant EU & UK directives. Further details of applied directives may be found in the product specification.

Electricity and pressurized gas can be dangerous. This product must be installed and operated only by suitable trained personnel.



**No user serviceable parts inside**



**Where this hazard warning symbol appears in the following sections, it is used to indicate areas where potentially hazardous operations need to be carried out and where particular attention to personal and personnel safety must be observed.**



**Where this symbol appears in the following sections it is used to indicate areas of potential risk of electric shock.**

This product is intended for use only under the following conditions:

- a. indoor use
- b. altitude up to 2 000 m
- c. temperature 0 °C...+50 °C
- d. <90 % rh non-condensing
- e. MAINS supply voltage fluctuations up to  $\pm 10$  % of the nominal voltage
- f. TRANSIENT OVERVOLTAGES up to the levels of OVERVOLTAGE CATEGORY II
- g. TEMPORARY OVERVOLTAGES occurring on the MAINS supply
- h. applicable POLLUTION DEGREE 2 of the intended environment

## Electrical Safety

Ensure electrical safety is complied with by following the directions provided here and observing all local operation & installation requirements at the intended location of use.

This product is completely safe when using any options and accessories supplied by the manufacturer of this product for use with it. Refer to Section 2 (Installation) of this manual for further details.

## Pressure Safety

For this product to operate satisfactorily, pressurized gas must be connected to it. Observe all the information contained within this manual and all local operation & installation requirements at the intended location of use. Refer to Section 2 (Installation) of this manual for further details.

## Hazardous Materials (WEEE, RoHS3 & REACH)

This product does not contain or release any prohibited chemicals listed on the SVHC (Substances of Very High Concern) Candidate List. During the intended normal operation of this product it is not possible for the user to come into contact with any hazardous materials. This product is designed to be recyclable except where indicated.

## Repair and Maintenance

The instrument must be maintained either by the manufacturer or an accredited service agent. For contact information visit the website at [www.ProcessSensing.com](http://www.ProcessSensing.com).

## Calibration

Periodic recalibration is recommended in order to maintain the highest quality of measurement in your application. Michell Instruments recommends that you have your moisture transmitters re-calibrated annually unless they are used in a mission-critical application or in a contaminated environment, in which case the calibration interval should be reduced accordingly.

Michell Instruments can offer a variety of re-calibration and exchange transmitter schemes to suit your specific needs. A local representative will be pleased to provide detailed custom advice.

For the maintenance and replacement of oxygen sensors, please refer to the Minox i Oxygen Transmitter User Manual.

## Safety Conformity

This product meets the essential protection requirements of the relevant EU & UK directives. Further details of applied standards may be found in Appendix C.

## Abbreviations

The following abbreviations are used in this manual:

A	Ampere
AC	alternating current
barg	pressure in bar (gauge)
°C	degrees Celsius
°F	degrees Fahrenheit
DC	direct current
dp	dew point
Hz	Hertz
lb/MMscf	pounds per million standard cubic feet
mA	milliampere
mg/m <sup>3</sup>	milligrams per cubic meter
mm	millimeters
NI/min	normal liters per minute
ppm <sub>v</sub>	parts per million by volume
psig	pressure in pound(s) per square inch (gauge)
scfh	standard cubic feet per hour
T	temperature
V	Volts
W	Watts
"	inch(es)



## 1 INTRODUCTION

This flexible multi-channel analyzer is designed to provide real-time, multi-parameter displays for our industrial hygrometer systems, for measurement of high-pressure process gases and vaporized liquids on natural gas platforms and terminals, petrochemical plants and industrial-gas manufacturing facilities. Optional oxygen electrochemical sensors offer additional capability for percentage and ppm<sub>v</sub> O<sub>2</sub> measurements. Combined with a choice of PST sensors and proven sample conditioning system design-engineering capabilities, the system provides a multi-channel online instrument for both flammable and non-flammable gases, that is reliable and easy to operate.

The Multi-Channel Process Monitor (MCPM) must be placed in a non-hazardous area suitable for electronic analytical equipment. The moisture and/or O<sub>2</sub> transmitters and optional pressure/temperature transmitters can be positioned close to the process sample take-off point in a Zone 1 or Zone 2 (Class I, Division 1, Groups A,B,C and D) hazardous area. The process monitor and transmitters are connected via a standard 2-wire instrumentation cable protected by safety isolation interface units.



Figure 1 *Multi-Channel Process Monitor (MCPM)*

## 1.1 Performance Features

- Enhanced functionality 6-channel capable process monitor, utilizing a single 7" touchscreen HMI
- Provides up to six independent measurement channels with any combination of moisture in gas, moisture in liquids or oxygen
- 7" color touchscreen LCD, displaying moisture content/dew point or O<sub>2</sub> and analysis pressure, with configurable, on display, tag names/numbers
- Integrated galvanic isolation-type barriers
- Three 4...20 mA configurable outputs per channel
- Modbus RTU over RS485 and Modbus TCP/IP communication
- Alarm indicators based on the NAMUR 102 standard
- Two alarm relays with user-programmable set points per channel, with additional system alarm
- Data logging to SD card, including measurement parameters and error codes
- Customized sampling systems to meet even the most demanding applications

## 1.2 Applications

- Natural gas production and processing
- Pipeline drying
- Offshore export pipeline natural gas
- Transmission pipeline monitoring
- Fiscal metering/custody transfer of gas
- Gas storage facilities
- Hydrogen production, storage and transportation including natural gas injection
- LNG production processing and receiving terminals
- Gas generation industries
- Refining, including ethylene/polyethylene plants
- Synthetic rubber production

### 1.3 Flexible Configuration Options

The MCPM supports 4, 5 or 6 channels in a single 19" rack mountable unit. It supports any combination of moisture in gas measurement using Promet I.S moisture sensors, moisture in liquid analysis with Liquidew I.S moisture sensors or oxygen measurement function using the Minox-i O<sub>2</sub> transmitter.

Each measurement channel functions totally independently, so that any maintenance on one channel will not affect the others. Customers can also order blank channels for future expansion, if required.

The MCPM supports the following PST sensors:

**Michell Promet I.S. Process Moisture Analyzer** A heavy-duty, industrial hygrometer system for measurement of high-pressure process gases and vaporized liquids on natural-gas platforms and terminals, petrochemical plants and industrial gas manufacturing facilities. The Promet I.S. combines Michell's proven ceramic moisture sensor with sample conditioning system design-engineering capabilities to provide a multi-channel online instrument for both flammable and non-flammable gases, that is reliable and easy to operate.

**Michell Liquidew I.S. Moisture in Liquid Analyzer** Provides accurate, fast and reliable online measurement of moisture content in liquids. A wide variety of non-polar liquids can be measured continuously, on line, including flammable liquids and hazardous-area applications, petrochemicals and petroleum refineries.

**PST Minox-i** A highly reliable and cost-effective two-wire, loop-powered transmitter with a linearized 4...20 mA output. The standard offering has a detection measurement range of 0...25 % oxygen. This compact transmitter utilizes advanced galvanic fuel-cell technology that provides a long sensor life with a high level of accuracy and stability.

In addition to the choice of intrinsically safe sensors, there are other options to give users support for a range of applications. For example, in applications where pressure varies, a real-time pressure sensor signal provides more accurate, active compensation for moisture content conversion (using an optional pressure sensor).

Also, sampling systems designed for measurement of flammable and non-flammable gas and complete packages can be supplied for use in explosive atmospheres, in accordance with the requirements of ATEX/ IECEx/UKCA or meeting the equivalent NEC HazLoc requirements for Class I, Div 1, and Class I Zones.

See the Michell ES70 Sampling System datasheet for full details.

1.4 System Components

The MCPM consists of:

- the sensor assemblies
- the Multi-Channel Process Monitor

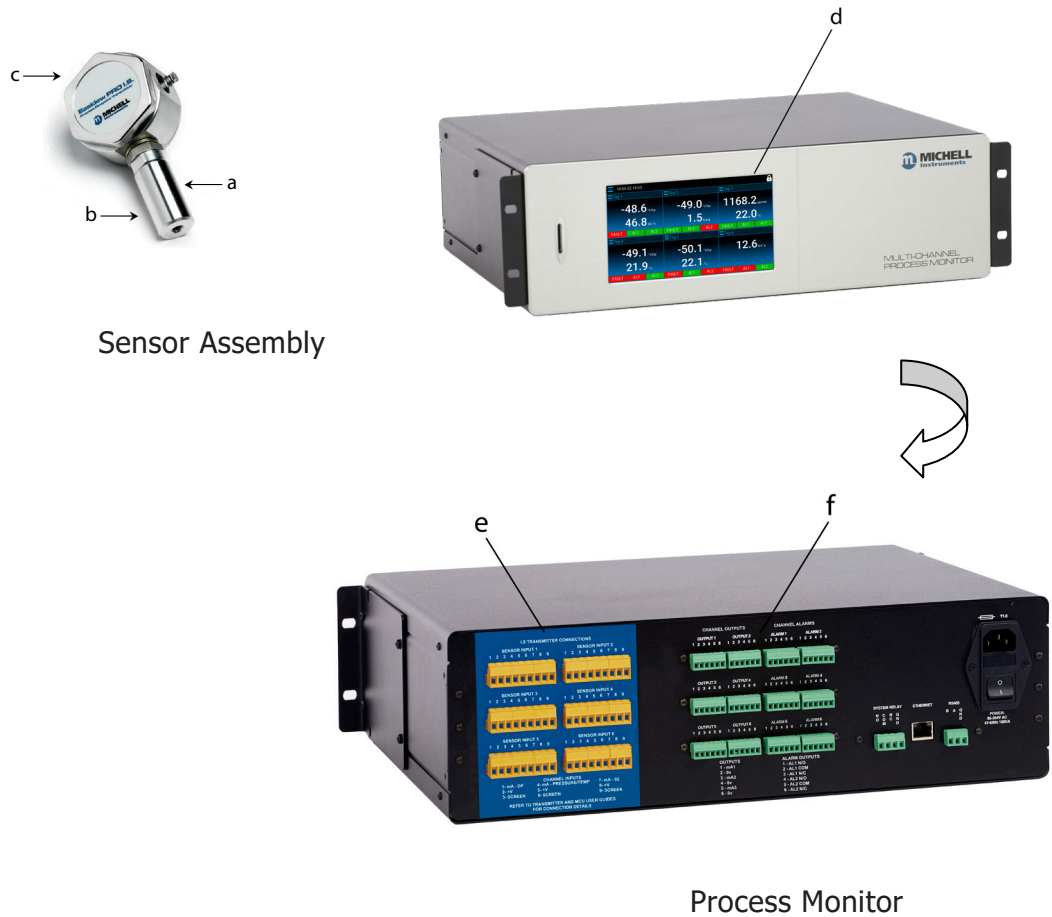

(Up to six channels can have any combination of Promet I.S., Liquidew I.S. or Minox-i O<sub>2</sub> sensors\*)

- |   |  |
|---|--|
| a | Port for optional pressure transmitter         |
| b | Sensor block                                   |
| c | Dew-point transmitter                          |
| d | User interface                                 |
| e | Electrical connections – to hazardous area     |
| f | Electrical connections – to non-hazardous area |

Figure 2 Major Components of the MCPM

\* Liquidew I.S. is a sister product of the Promet I.S. used for moisture in liquid measurement; Minox-i is an electrochemical oxygen sensor

### 1.4.1 Input/Output Signal

The terminal blocks for the signal input, signal output and alarm output are located on the back panel of the process monitor (see *Figure 6*).

- **Signal Input**

There are three 4...20 mA signal inputs per channel. All input channels are isolated by built-in galvanic-type I.S. barriers.

- **Signal Output**

There are three 4...20 mA linear signal outputs per channel. Each output can be set for either dew point, pressure, ppm<sub>v</sub>(I), lbmmscf, mg/m<sup>3</sup>, ppm<sub>v</sub>(N) % or ppm<sub>v</sub> O<sub>2</sub>.

There is one RS485 Modbus RTU digital communication port. Refer to Appendix B.

- **Alarm Output**

There are two form-C volt free contact alarms per channel, which are user-settable. In addition, there is a universal fault alarm to indicate a fault with any of the connected inputs.

## 1.5 Sampling System

Sample extraction, handling and conditioning techniques are of critical importance to assure optimal performance and reliability of all analyzers that accurately quantify specific components within a process gas or liquid composition.

Michell Instruments has almost 50 years' experience providing dew-point and moisture-measurement solutions. We also design and manufacture a broad range of sampling systems for a wide spectrum of industries.

Our sampling system designs ensure that dew-point and moisture measurements can be performed in the most suitable conditions. Sampling systems can be supplied in various configurations and are designed to be used in conjunction with various PST moisture content / dew-point or O<sub>2</sub> sensors.

Our sample systems provide a choice of indoor or outdoor compatibility, sensor mount selection, along with a wide range of features to facilitate regulation of pressure and flow and the removal of contaminants. This enables the system to deliver a properly conditioned sample to the analyzer for reliable measurements and trouble-free operation. The optional integrated bypass system increases transport speed of the sample while reducing wastage. Each high-quality sample system is constructed from 316 stainless steel components, with BS EN 10204 3.1 material certificates and compliance to MR 0175/ISO 15156 available on request.

**NOTE: Contact Michell Instruments if you wish to order a specific sampling system.**

Please refer to the ES70 Sampling System manual if a Michell sampling system has been ordered with the MCPM.

## 2 INSTALLATION



**DANGER**  
Electric  
Shock Risk

**It is essential that the installation of the electrical and gas supplies to this analyzer be undertaken by suitably qualified personnel.**

### 2.1 Unpacking the System

Unpack carefully as follows:

- a. Remove the accessories (if ordered).
- b. If no accessories have been ordered, the delivery should contain the following items:
  - MCPM
  - Moisture content/dew-point or O<sub>2</sub> sensors (if a sampling system has been ordered, the sensor assemblies should already be mounted in the sampling system)
  - Certificates of calibration and conformity
  - Power lead (only for 85...264 V AC version)
- c. Remove the sensor assemblies from the box.
- d. Lift out the unit together with its end packing pieces.
- e. Remove the end packing pieces and set down the unit at the site of installation. Save all the packing materials for the purpose of returning the instrument to the manufacturer for service.

If ordered, the ES70 Sampling System will be shipped in a separate box.

## 2.2 Environmental Requirements

The compatible sensors need to be intrinsically safe and designed to be installed on site, indoors or outdoors, directly at the point of measurement within a hazardous area. The sensor assemblies are ATEX, UKCA, IECEx and QPS certified (to be specified at time of order). To operate correctly, the sensor must be installed within a suitable sampling system (Michell Instruments can supply standard and custom-designed sampling systems).

The MCPM is NOT designed for use in a hazardous area and should only be installed in a safe area. The monitor is intended for indoor installation only and operates within environmental limits of 0...+50 °C (+32...+122 °F) and <90 %rh.

## 2.3 Process Monitor Installation

This monitor is housed in a 19" sub-rack case which can be bench or rack mounted using the optional mounting brackets.

**NOTE: The materials and construction of the process monitor allow for operation in an indoor, clean, non-hazardous only, control room environment.**

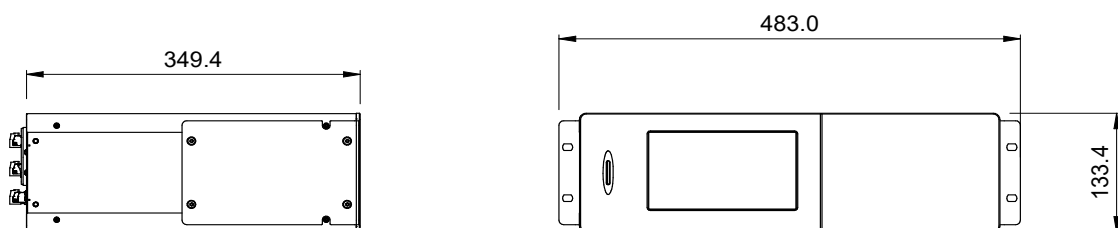

Figure 3 *Dimensions of the Process Monitor (in mm)*

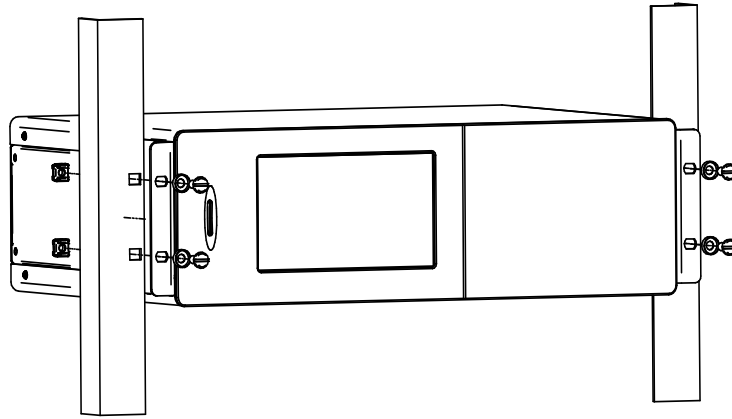

Figure 4 *Rack Mounting Method*

Figure 5 illustrates the general method for fitting a rack mount instrument into a standard 19" rack. To fit the unit proceed as follows:

- a. Remove all terminal blocks for the electrical connections.
- b. If necessary, remove any covers from the rack cabinet to gain access to the rear and side.
- c. Connect up the sensor input, analog and alarm output terminal blocks to the internal rack wiring, ensuring that there is sufficient free cable to permit withdrawal of the instrument from the rack.
- d. Slide the instrument into the rack and support its weight while the four fixing screws are inserted.
- e. Ensure that the front panel of the instrument is flush and square with the front of the rack and tighten the fixing screws.
- f. Insert the terminal blocks into their respective sockets on the rear of the instrument.
- g. Connect the power supply cable and switch the **ON/OFF** switch to **ON**.
- h. Re-fit any covers to the rack as necessary.

**NOTE: Allow a minimum clearance depth of 100 mm (4") behind the instrument housing for cables and vents.**



2.4 Wiring



**DANGER**  
Electric  
Shock Risk

These tasks are to be undertaken only by suitably qualified personnel. All the connections to the rear panel are electrical connections. Exercise due caution, particularly when connecting to external alarm circuits which could be at high potential.

2.4.1 Overall Wiring Arrangement

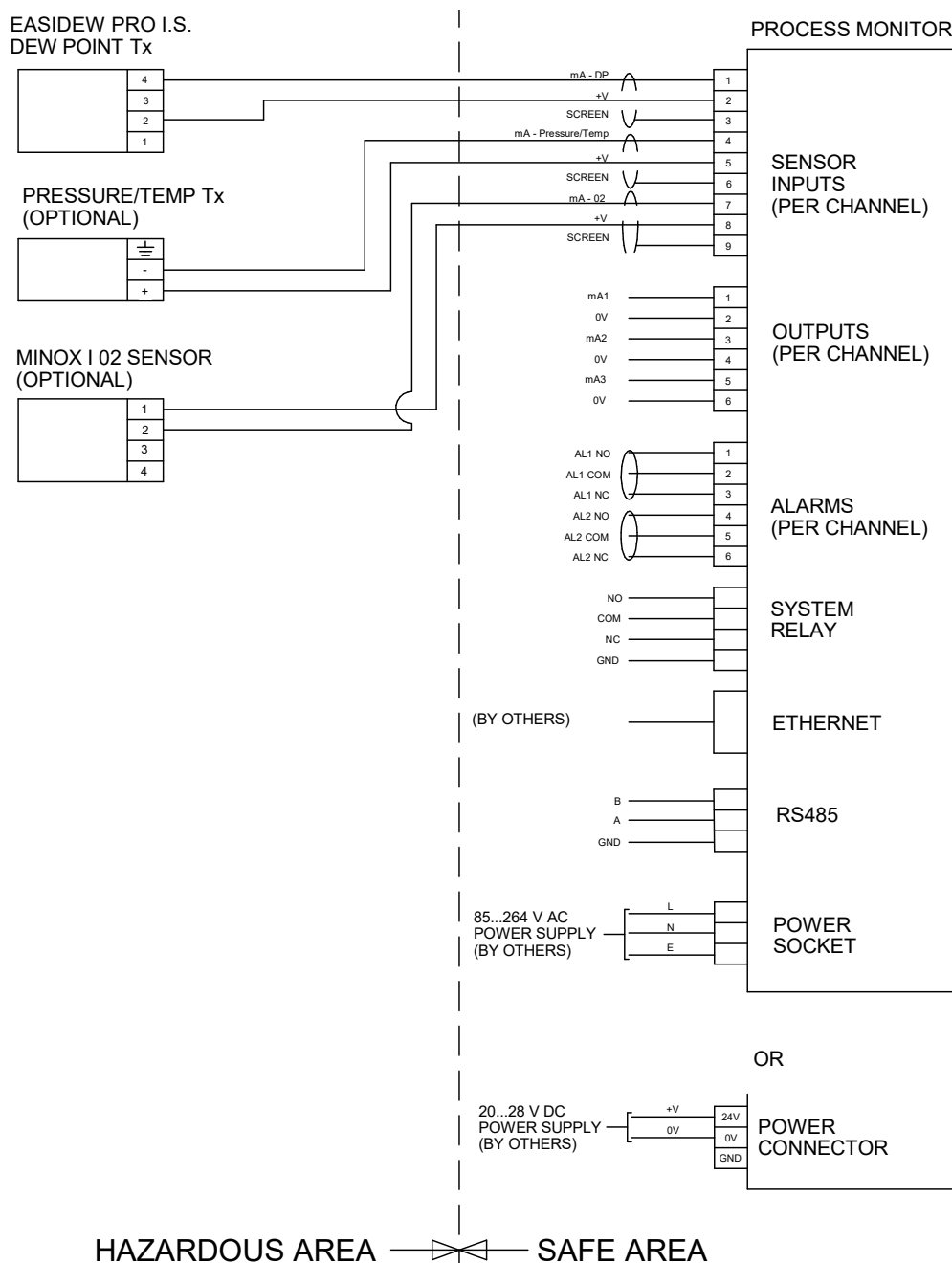

Figure 5 Overall Wiring Arrangement

2.4.2 Process Monitor Wiring

The electrical connections are located at the rear panel of the process monitor. There are spaces for six individual channels.



**HAZARDOUS AREA INFORMATION:**

**The only connections on the process monitor which can take cables from hazardous area are the connectors labelled I.S. SENSOR INPUTS.**

**ALL OTHER CONNECTORS MUST NOT BE CONNECTED TO CABLES FROM HAZARDOUS AREA**



**NOTE: Make sure channels are connected correctly.**

**Connections for each channel are identical.**

**The following text will only refer to one channel.**

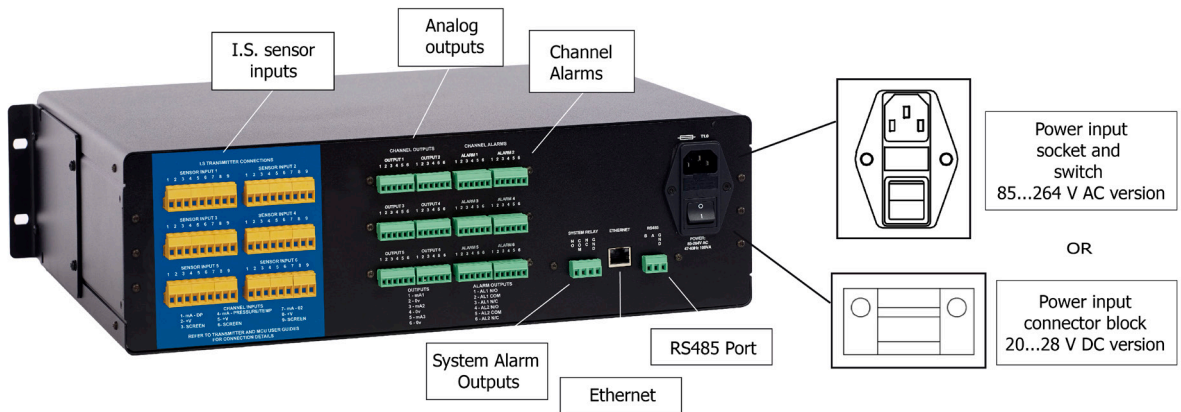

Figure 6 MCPM Electrical Connections

For sensor wiring, refer to the user manual for the appropriate sensor (available at [www.ProcessSensing.com](http://www.ProcessSensing.com)).

### 2.4.2.1 Power Supply Input Connection

#### 85...264 V AC

The AC power supply connection is a push-fit socket (see *Figure 6*).

The method of connection is as follows:

- Turn off the AC power. Ensure that both ends of the power cable are potential free, i.e. not connected to an AC power supply.
- Check that the **ON/OFF** switch is switched to **OFF**.
- Push the IEC connector firmly into the **POWER INPUT** socket.
- Connect the free end of the power cable to a suitable AC power supply source (voltage range 85...264 V AC, 47/63 Hz) and switch on the AC supply. The instrument may then be switched on, as required, by pressing the **ON** switch.

#### 20...28 V DC

If a DC power supply version is ordered, it will come with a 3-way push-fit connector block labelled **POWER INPUT** as shown below.

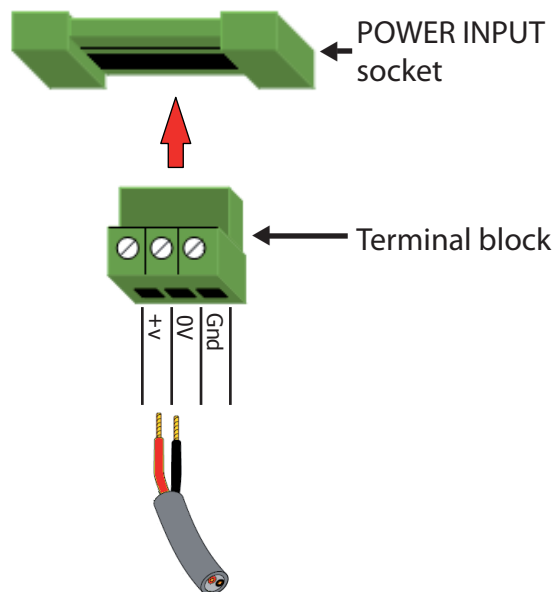

Figure 7 *POWER INPUT Connector Block*

The method of connection is as follows:

- Turn off the power. Ensure that both ends of the power cable are potential free i.e., not connected to a power supply.
- Remove the terminal block from the **POWER INPUT** socket.
- Strip back the wires of the power cable, exposing approximately 6 mm (0.2") – the use of crimps/wire ferrules is recommended.

- d. Insert the +V DC lead into the +V terminal way on the terminal block and tighten the screw.
- e. Insert the 0 V lead into the 0 V terminal way on the terminal block and tighten the screw.
- f. Check that the wiring has been completed correctly.
- g. Push the terminal block firmly back into the **POWER INPUT** socket.

**NOTE: There is no power switch for the DC power supply version; the analyzer will be turned on automatically as soon as power is supplied.** Connect the free end of the power cable to a suitable DC power supply source (voltage range 20...28 V DC). The instrument may then be switched on, as required, by the power switch at the source.

## 2.4.2.2 Sensor Signal Input Connection

**HAZARDOUS AREA INFORMATION**

Cables from transmitters mounted in hazardous areas can be connected directly to the **SENSOR INPUTS** connector block. There are built-in Galvanic I.S. barriers for all connections made to this connector block.

Refer to **ATEX/UKCA/QPS/IECEX** certificates for the dew-point and optional pressure/temperature transmitters' connection cable requirements, which stipulate maximum permissible mutual capacitance and inductance to resistance ratio.

All wiring procedures should be in accordance with local electrical codes.

Three 4...20 mA input ports are provided per channel, for a dew point, a temperature or pressure, and for an O<sub>2</sub> sensor as shown below:

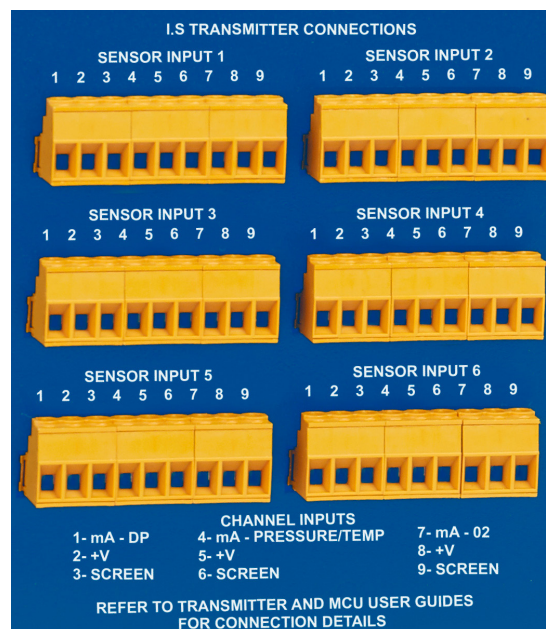

Figure 8 *SENSOR INPUTS* Connector Block

The method of connection is as follows:

- Remove the terminal block from the **SENSOR INPUTS** socket.
- Strip back the wires of the transmitter signal cable, exposing approximately 6 mm (0.2") – the use of crimps/wire ferrules is recommended.
- Insert the +ve (4...20 mA) wire into the +V terminal way on the terminal block and tighten the screw.
- Insert the -ve (4...20 mA) wire into the mA-DP terminal way on the terminal block and tighten the screw.
- Repeat steps b., c. and d. for pressure/temperature and O<sub>2</sub> transmitters.
- Check that the wiring has been completed correctly.
- Push the terminal block firmly back into the **SENSOR INPUTS** socket.

**2.4.2.3 Analog Output Connection**

Three user-settable 4...20 mA outputs are provided per channel. See the relevant sub-sections of Section 3 for details on output configuration.

Terminal Block Pin	Output
1	mA1
2	0V
3	mA2
4	0V
5	mA3
6	0V

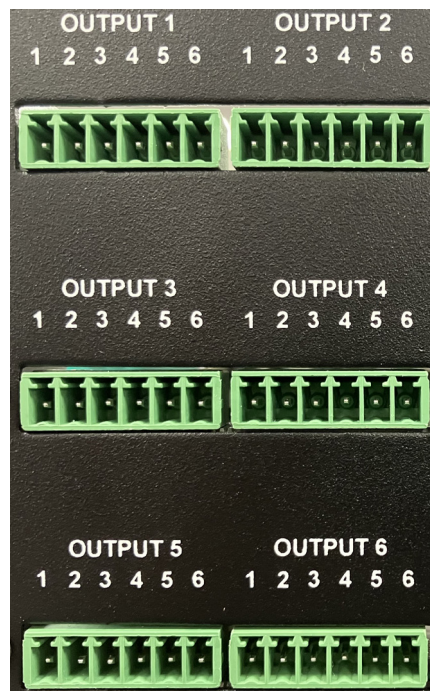

Figure 9 *SENSOR OUTPUTS Connector Block*

The method of connection is as follows:

- a. Remove the terminal block from the **OUTPUT** socket.
- b. Strip back the wires of the signal cable, exposing approximately 6 mm (0.2”) – the use of crimps/wire ferrules is recommended.
- c. Insert the +ve (4...20 mA) wire into the **mA1** terminal way on the terminal block and tighten the screw.
- d. Insert the -ve (4...20 mA) wire into the **0V** terminal way on the terminal block and tighten the screw.
- e. Repeat steps b, c and d if the second (**mA2**) and third (**mA3**) outputs are required.
- f. Check that the wiring has been completed correctly.
- g. Push the terminal block firmly back into the **OUTPUT** socket.

### 2.4.2.4 Alarm Connection

Two Form-C alarms are provided for each channel. See *Figure 9*.

Alarm 1 (connection labelled as AL1) and Alarm 2 (connection labelled as AL2) are Form C (single pole, double throw) relays.

The method of connection is as follows:

- Remove the terminal block from the **ALARMS** socket.
- Strip back the wires of the Alarm 1 cable, exposing approximately 6 mm (0.2") – the use of crimps/wire ferrules is recommended.
- Insert the **N/O** connection lead into the **AL1 → NO** terminal way on the terminal block and tighten the screw.
- Insert the **N/C** connection lead into the **AL1 → NC** terminal way on the terminal block and tighten the screw.
- Insert the common lead into the **AL1 → COM** terminal way on the terminal block and tighten the screw.
- Repeat operations b. to e. for connecting the Alarm 2 cable to the AL2 terminals.

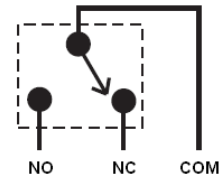

### 2.4.2.5 RS485 Port Connection

For details of the RS485 connection, please refer to Appendix B.

Modbus TCP/IP is also available using the RJ45 Ethernet connection provided. Ethernet configuration is shown in Section 3.2.3 and Appendix B.

### 2.4.3 Sensor Assembly Wiring

**NOTE: If the analyzer has been ordered with a sampling system, the sensor assemblies will be wired up to the junction box in the factory. In that case, disregard the following instructions and go to Section 3.**

For other sensor wiring information, please see the relevant sensor datasheets and user manuals.

### 3 OPERATION

#### 3.1 Main Screen

Individual channels can be enabled or disabled. The screenshots below show all channels are enabled/active.

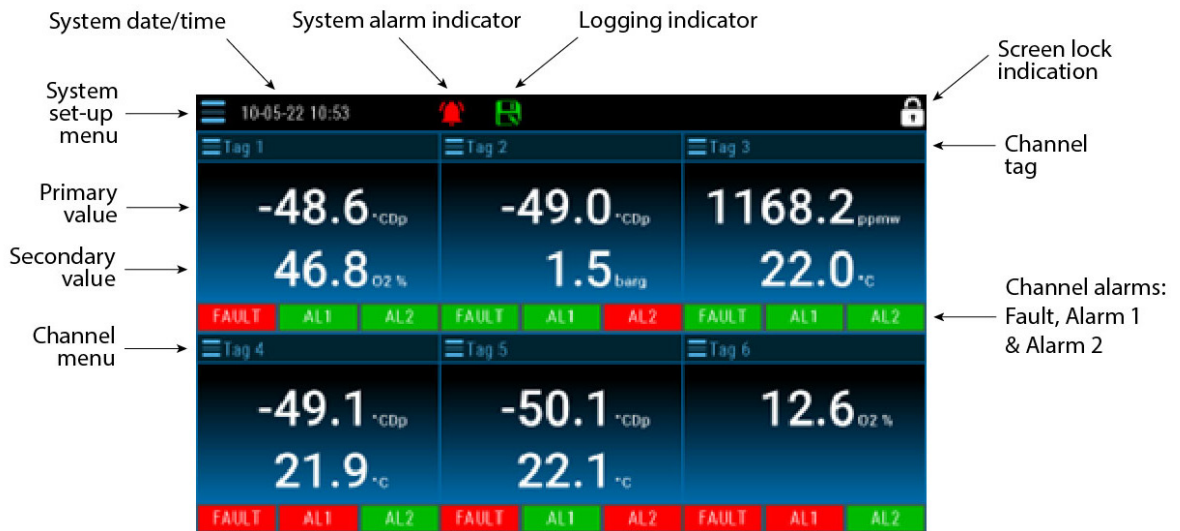

Figure 10 6-Channel Version

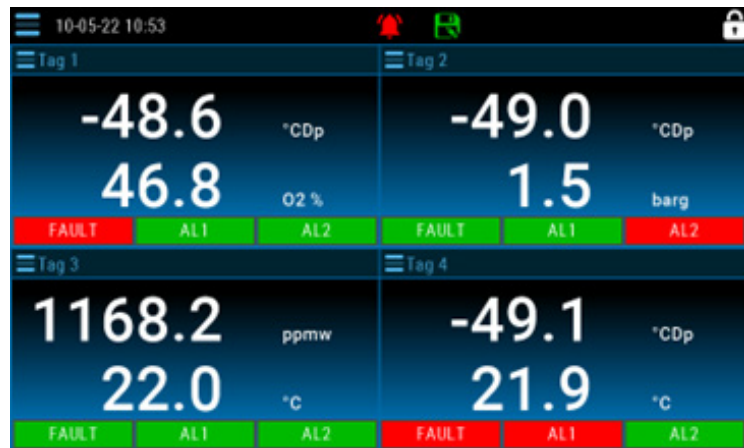

Figure 11 4-Channel Version



## 3.2 System Setup

The System Setup menu icon can be found at the top left of the main screen (next to date/time).



Figure 12 *System Setup Menu*

The System Setup menu provides access to main system configuration screens.

### 3.2.1 Date/Time

The Date/Time screen allows the user to read and adjust the system date and time.



Figure 13 *Date/Time Screen*

### 3.2.2 Logging

The Logging screen allows the user to start and stop internal logging to SD card.

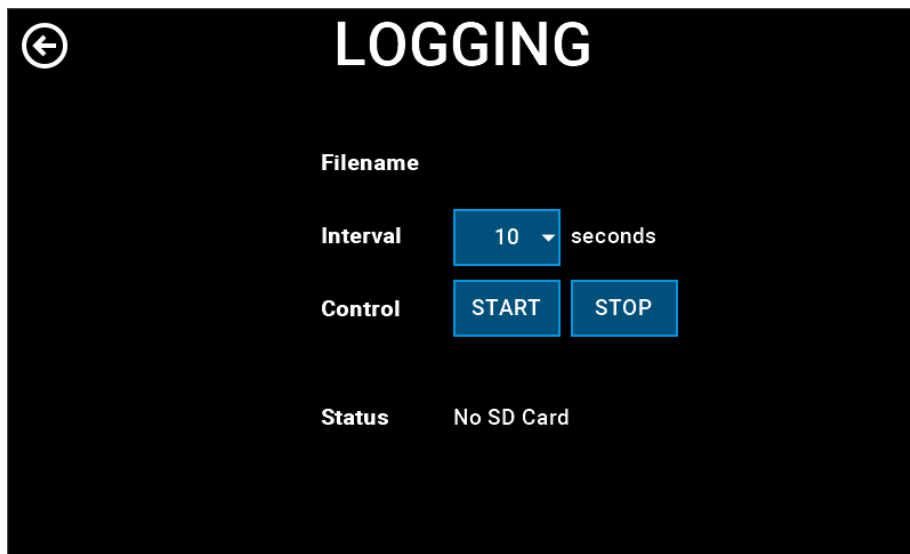

Figure 14 *Logging Screen*

Logging interval options are 10, 30, 60 and 120 seconds.

Logging can only be started when an SD card is present and working correctly.

On starting a log, a filename is automatically created in the following format:

ddHHmmss.txt

dd = system day (2 digits); HH = system hour (24 hour, 2 digits); mm = system minutes (2 digits); ss = system seconds (2 digits)

**Note:** When the system is logging, the user cannot change any settings.

### 3.2.3 Communications

The Communications screen allows the user to set the Modbus address and Modbus TCP settings.

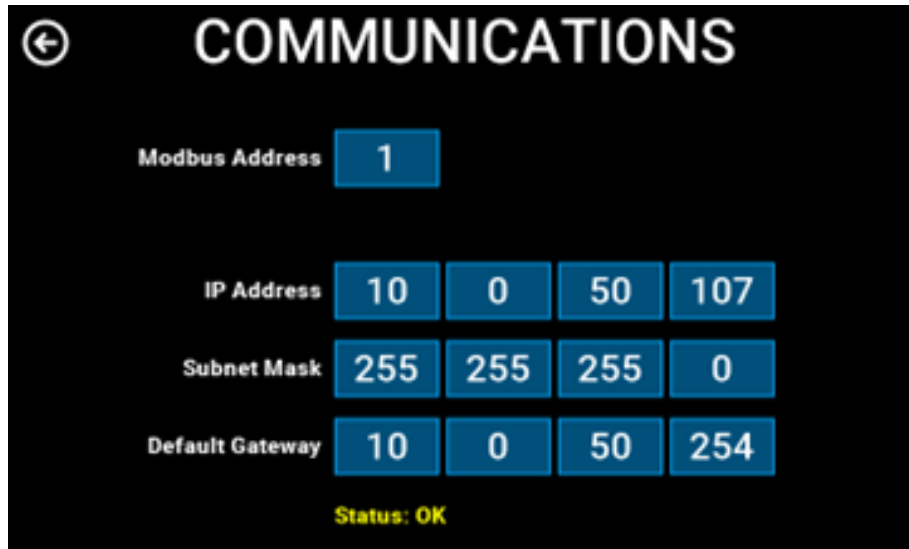

Figure 15 Communications Screen

### 3.2.4 System Alarm

The System Alarm screen allows the user to set which channel affects the system (global) alarm.

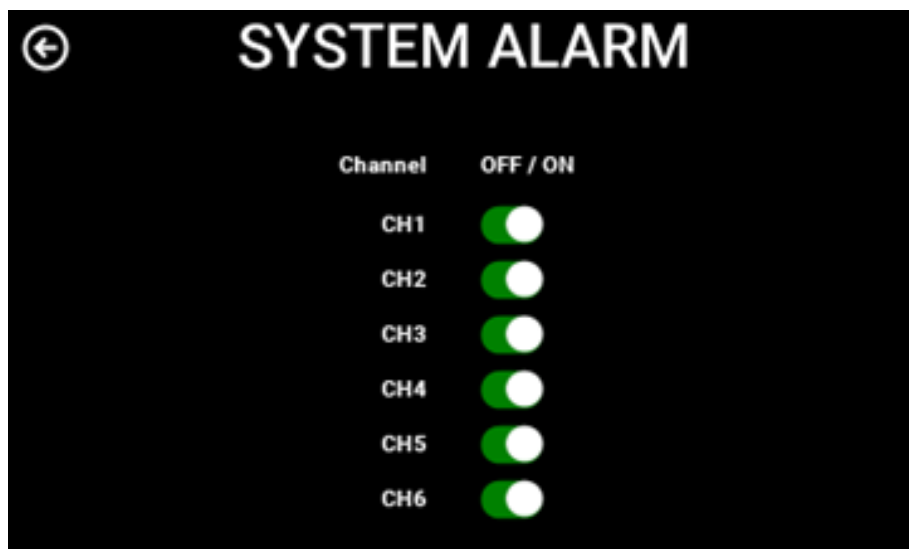

Figure 16 System Alarm Screen

### 3.2.5 Channel Type

The Channel Type screen allows the user to set the channel types (gas, liquid, oxygen or disabled), as well as channel tags (identification).

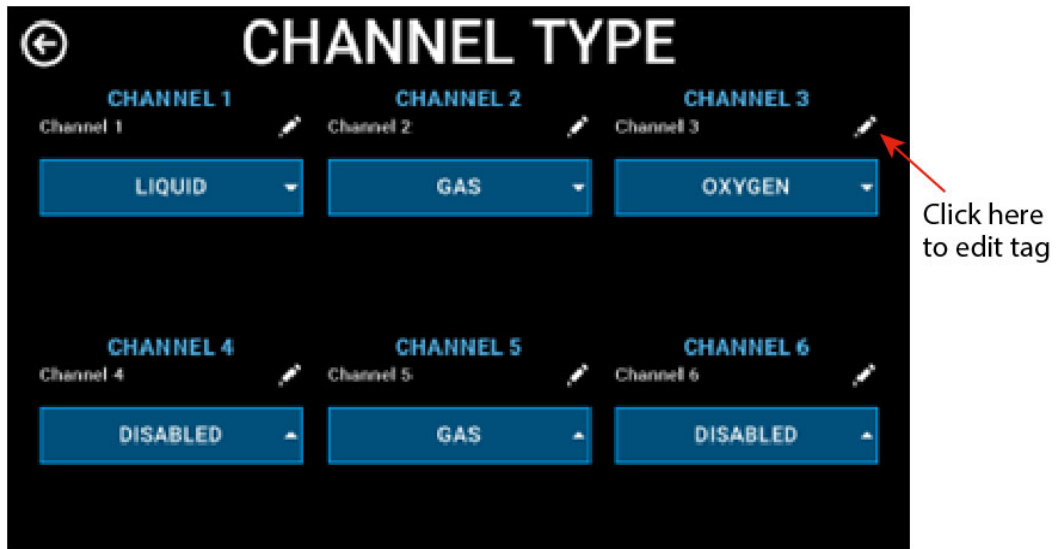

Figure 17 Channel Type Screen

### 3.2.6 About

The About screen shows firmware version numbers for the digital and analog PCBs, as well as the display.



Figure 18 About Screen

### 3.3 Channel Menu

To access specific channel settings, press the channel setup menu icon, which is found at the top left of the channel.

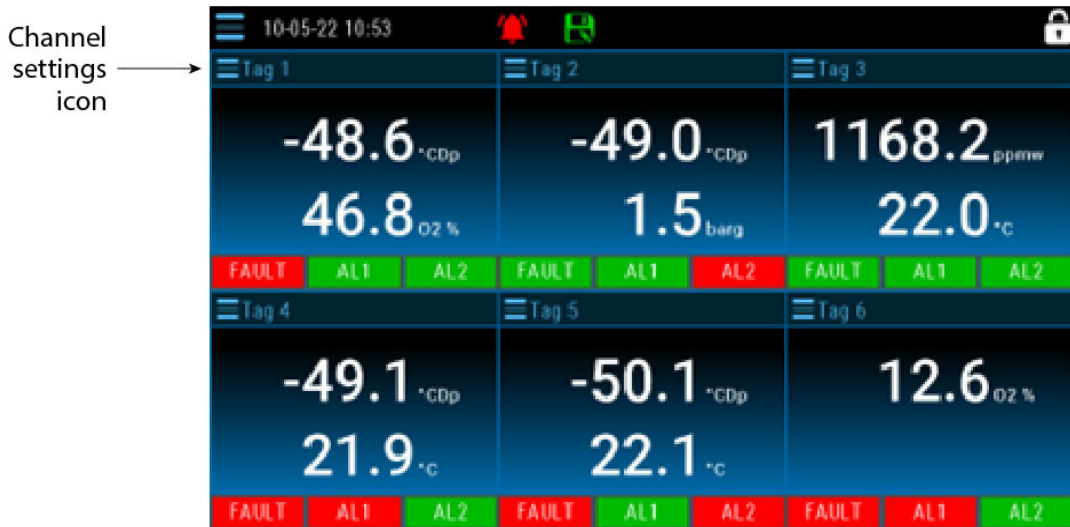

Figure 19 Channel Type Screen

#### 3.3.1 Liquid Channel

The channel setup menu for a liquid-type channel is shown below.

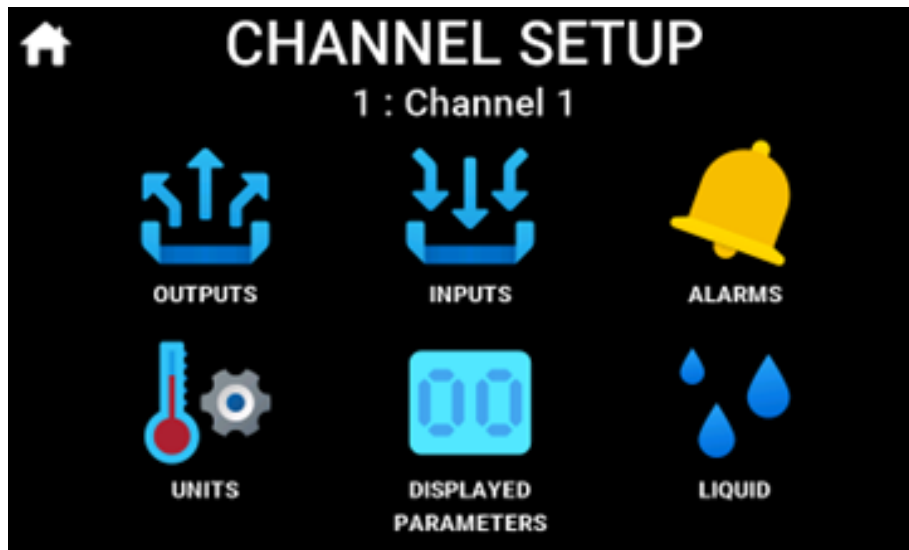

Figure 20 Liquid Channel Setup Screen

The channel setup menu provides access to main channel configuration screens.

### 3.3.1.1 Liquid Channel: Outputs

The Outputs screen allows the user to read and edit settings for the three outputs associated with the channel.

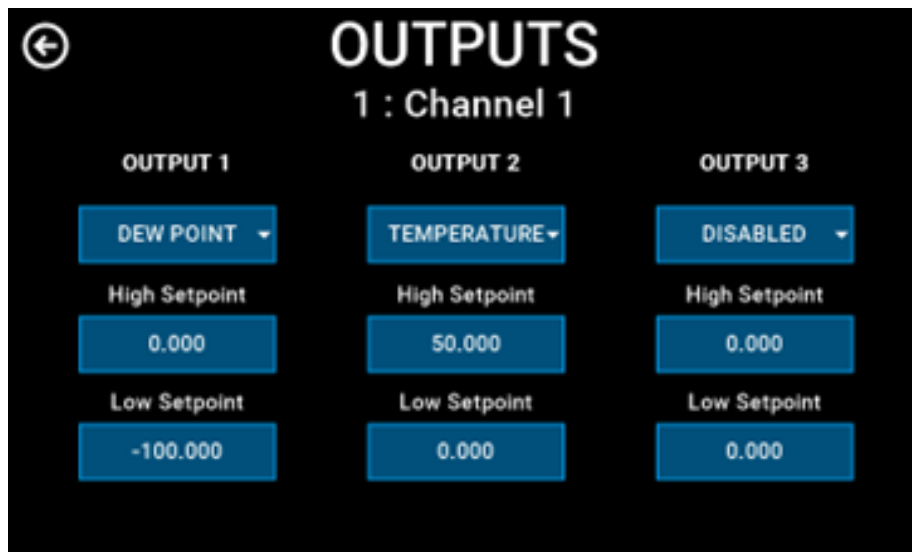

Figure 21 *Outputs Screen for the Liquid Channel*

Output type may be set to Dew Point, Moisture, Temperature or Disabled.

### 3.3.1.2 Liquid Channel: Inputs

The Inputs screen allows the user to read and edit settings for the two inputs associated with the channel.

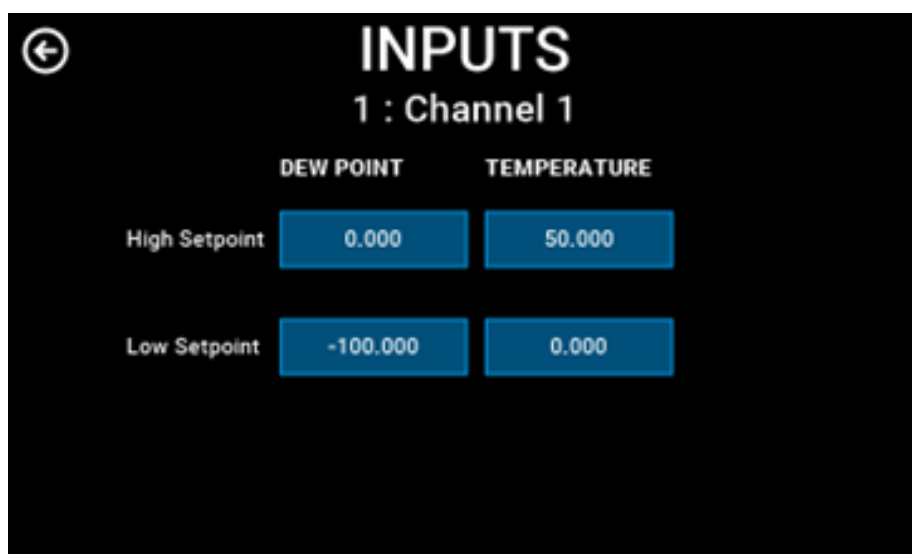

Figure 22 *Inputs Screen for the Liquid Channel*

### 3.3.1.3 Liquid Channel: Alarms

The Alarms screen allows the user to read and edit settings for the two alarms associated with the channel.

Additional information includes the effect the channel has on the system (global) alarm.

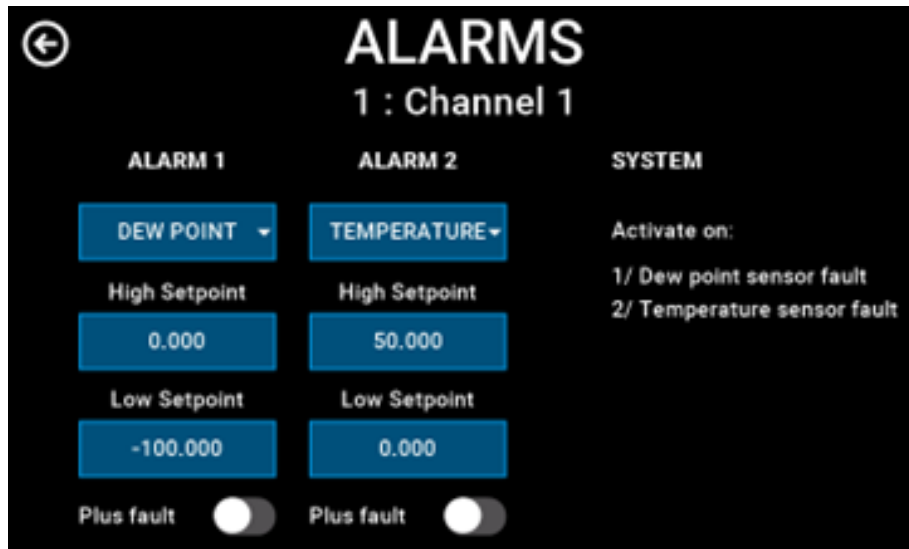

Figure 23 Alarms Screen for the Liquid Channel

Alarm type may be set to Dew Point, Moisture, Temperature or Disabled.

The "Plus fault" option means the alarm will also be set if there is a fault with the inputs for this channel.

### 3.3.1.4 Liquid Channel: Units

The Units screen allows the user to change the temperature unit. Options are °C or °F.

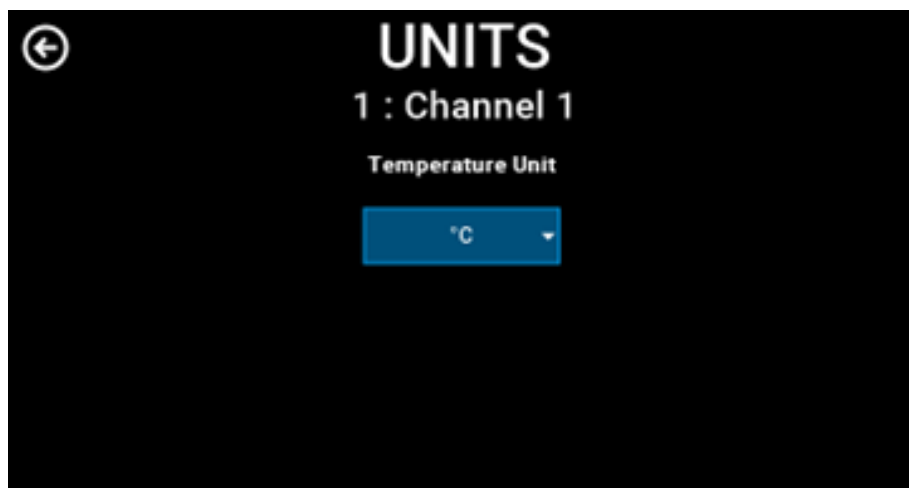

Figure 24 Units Screen for the Liquid Channel

### 3.3.1.5 Liquid Channel: Displayed Parameters

The Displayed Parameters screen allows the user to change the top parameter type. Options are Dew Point or Moisture.

The bottom parameter type is fixed as Temperature.

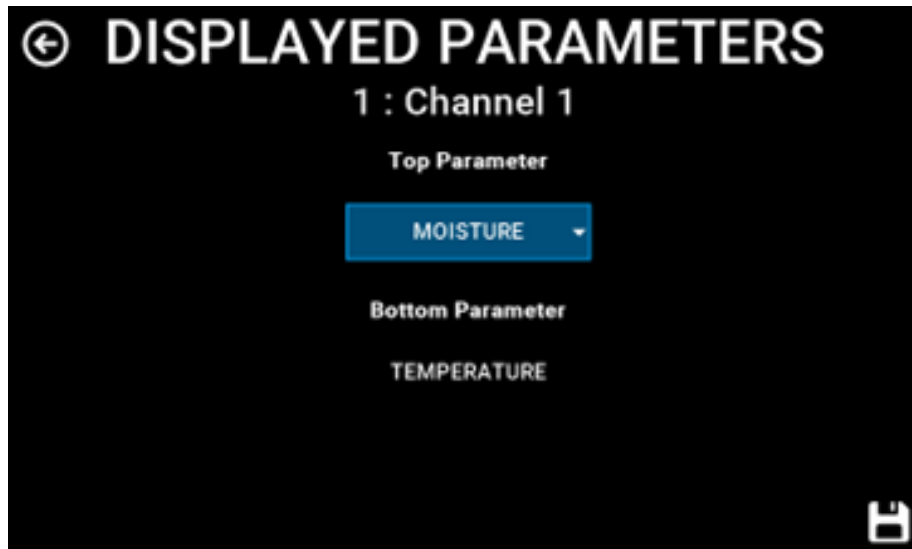

Figure 25 *Displayed Parameters Screen for the Liquid Channel*



### 3.3.1.6 Liquid Channel: Liquid Menu

The Liquid Menu screen allows the user to select a main liquid type, including 18 pre-defined liquids, two user-defined liquids and a mixing option.

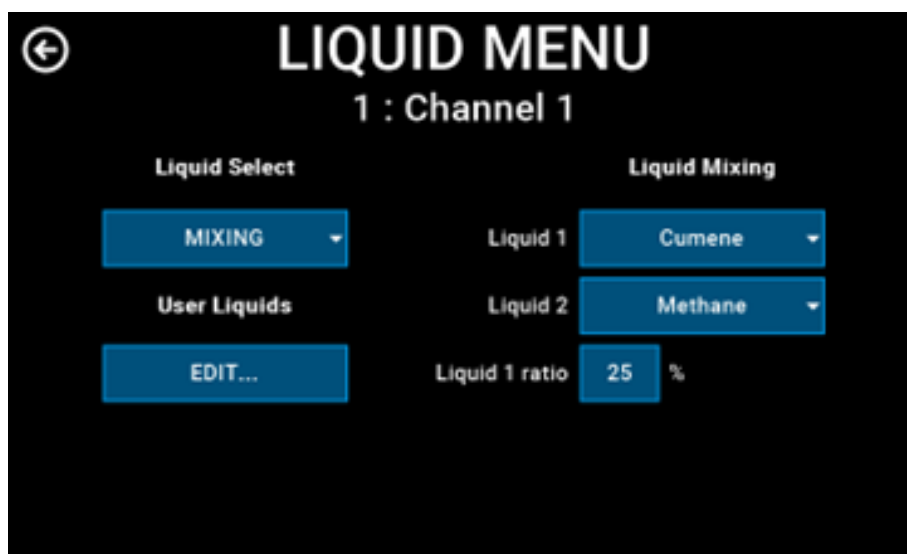

Figure 26 *Liquid Menu Screen for the Liquid Channel*

Liquid choice list:

n-butane	Ethane
n-propane	Methylcyclohexane
n-hexane	Butylbenzene
Cumene	Prop-1-ene
Benzene	But-1-ene
Toluene	Methane
1-butane	2-methylbutane
Cyclohexane	USER 1
Oct-3-ene	USER 2
Ethylbenzene	MIXING
Diethylbenzene	

When Mixing is selected, the user chooses two liquids to mix (including the user-defined types) and a mixing ratio.

### 3.3.1.7 Liquid Channel: User Liquids

The User Liquids screen allows the user to view and edit the two user-defined liquid types.

The temperature range is -20...+70 °C in 10 °C steps.

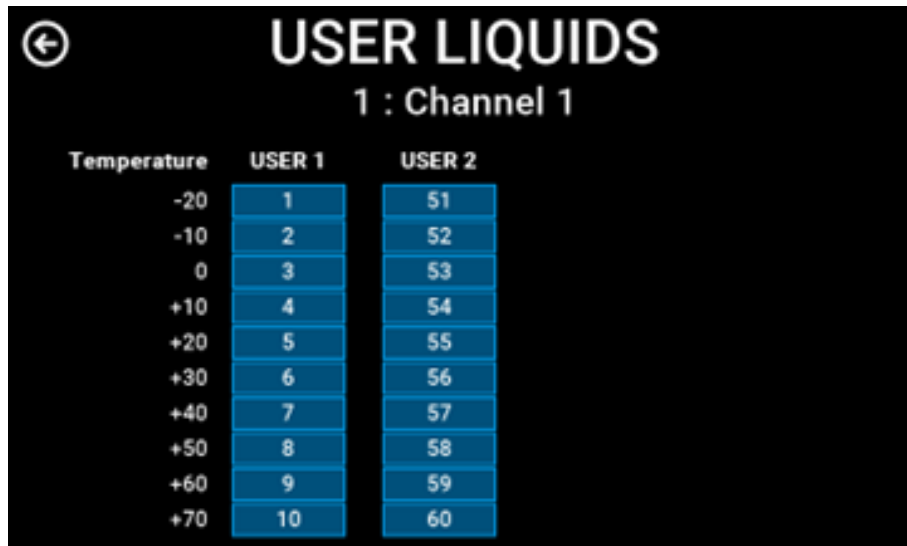

Temperature	USER 1	USER 2
-20	1	51
-10	2	52
0	3	53
+10	4	54
+20	5	55
+30	6	56
+40	7	57
+50	8	58
+60	9	59
+70	10	60

Figure 27 *User Liquids for the Liquid Channel*

### 3.3.2 Gas Channel

The channel setup menu for a gas-type channel is shown below.

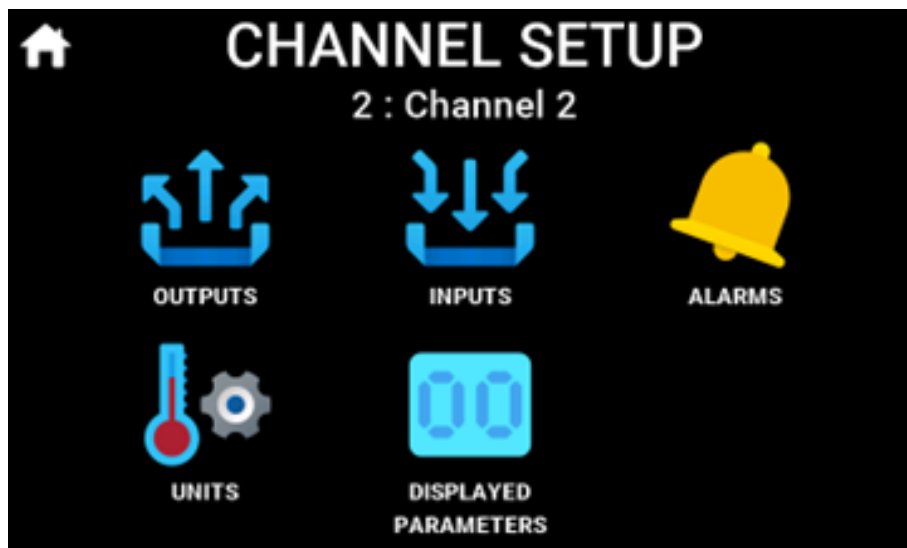

Figure 28 *Gas Channel Setup Screen*

The channel setup menu provides access to main channel configuration screens.

### 3.3.2.1 Gas Channel: Outputs

The Outputs screen allows the user to read and edit settings for the three outputs associated with the channel.

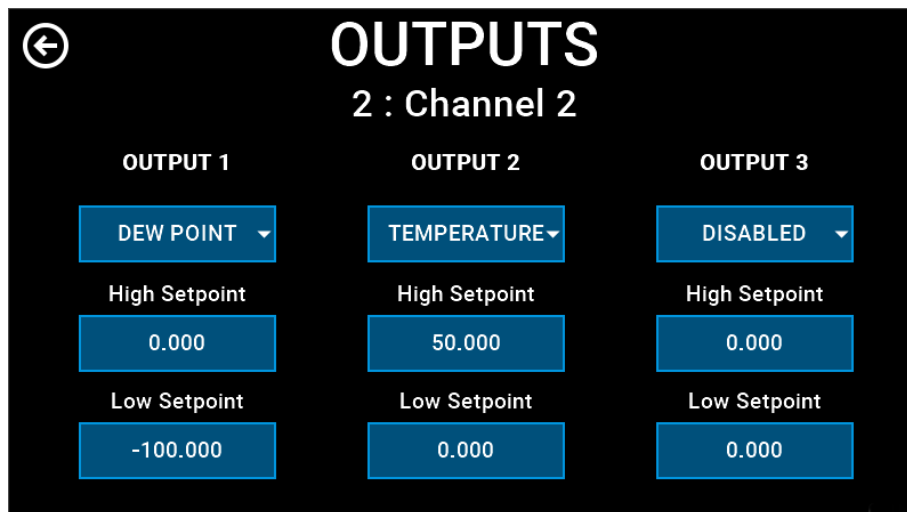

Figure 29 Outputs Screen for the Gas Channel

**When Oxygen is not fitted to the channel,** the output type may be set to Dew Point, ppm<sub>v</sub> (ideal), lbmmscf, mgm<sup>3</sup>, ppm<sub>v</sub> (natural gas), Pressure or Disabled.

**When Oxygen is fitted to the channel,** the output type may be set to Dew Point, ppm<sub>v</sub> (ideal), lbmmscf, mgm<sup>3</sup>, ppm<sub>v</sub> (natural gas), Pressure, Oxygen or Disabled.

### 3.3.2.2 Gas Channel: Inputs

The Inputs screen allows the user to read and edit settings for the two standard inputs and a third optional input (oxygen) associated with the channel.

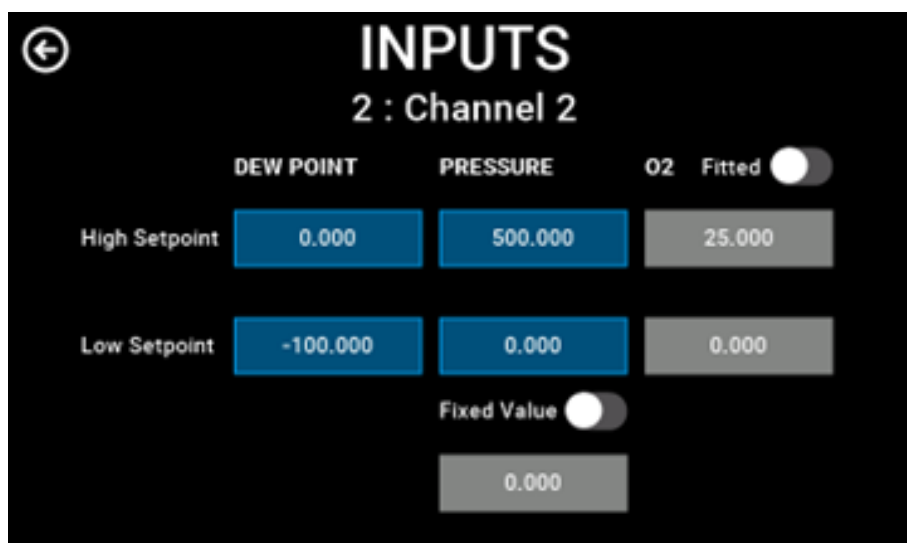

Figure 30 Inputs Screen for the Gas Channel

Pressure may be live from an external pressure sensor or a fixed value.

### 3.3.2.3 Gas Channel: Alarms

The Alarms screen allows the user to read and edit settings for the two alarms associated with the channel.

Additional information includes the effect the channel has on the system (global) alarm.

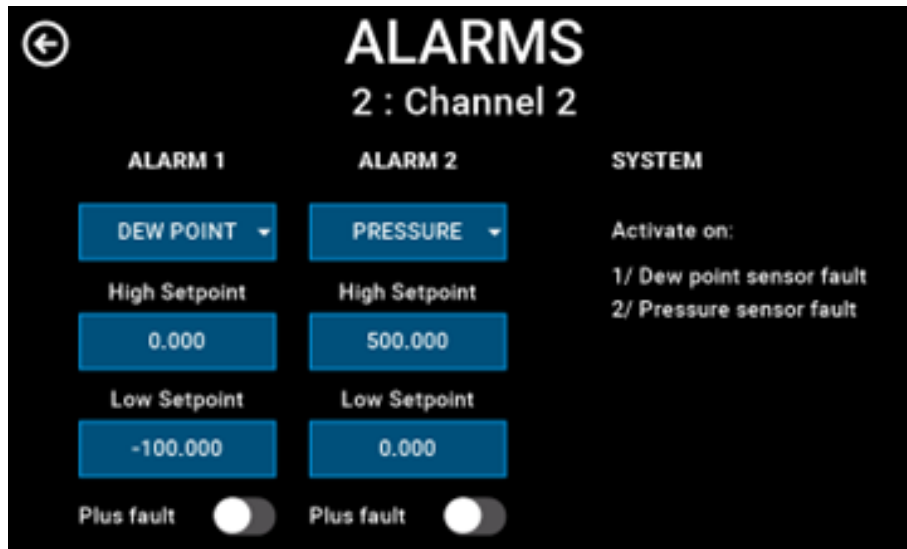

Figure 31 *Alarms Screen for the Gas Channel*

**When Oxygen is not fitted to the channel,** the alarm type may be set to Dew Point, ppm<sub>v</sub> (ideal), lbmmscf, mgm<sup>3</sup>, ppm<sub>v</sub> (natural gas), Pressure or Disabled.

**When Oxygen is fitted to the channel,** the alarm type may be set to Dew Point, ppm<sub>v</sub> (ideal), lbmmscf, mgm<sup>3</sup>, ppm<sub>v</sub> (natural gas), Pressure, Oxygen or Disabled.

The "Plus fault" option means the alarm will also be set if there is a fault with the inputs for this channel.

### 3.3.2.4 Gas Channel: Units

The Units screen allows the user to change the temperature, pressure and oxygen (if fitted) units. Temperature options are °C or °F, pressure options are barg or psig and oxygen options are % or ppm.

An ISO or IGT option is also provided.

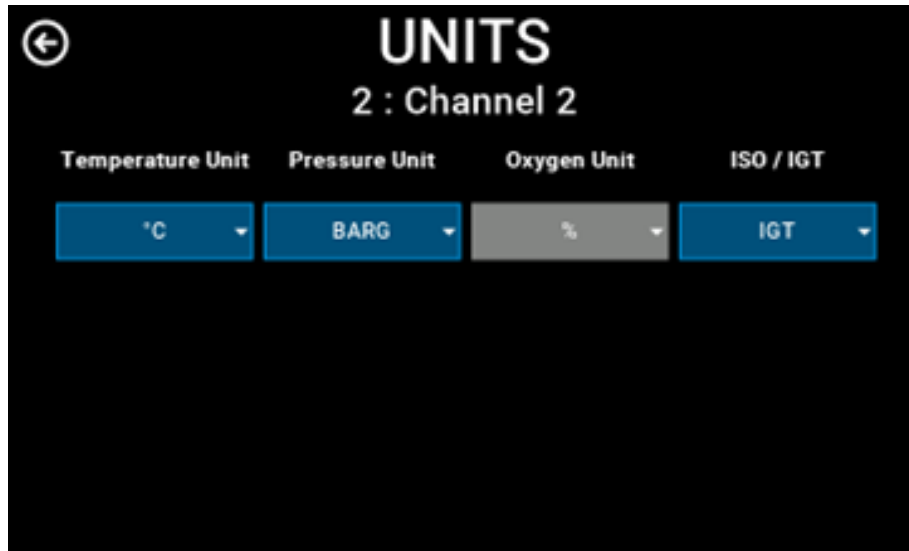

Figure 32 Units Screen for the Liquid Channel

### 3.3.2.5 Gas Channel: Displayed Parameters

The Displayed Parameters screen allows the user to change both the top and bottom parameter type. Top parameter options are Dew Point, ppm<sub>v</sub> (ideal), lbmmscf, mgm<sup>3</sup> and ppm<sub>v</sub> (natural gas).

The bottom parameter options are Pressure and Oxygen (if fitted).

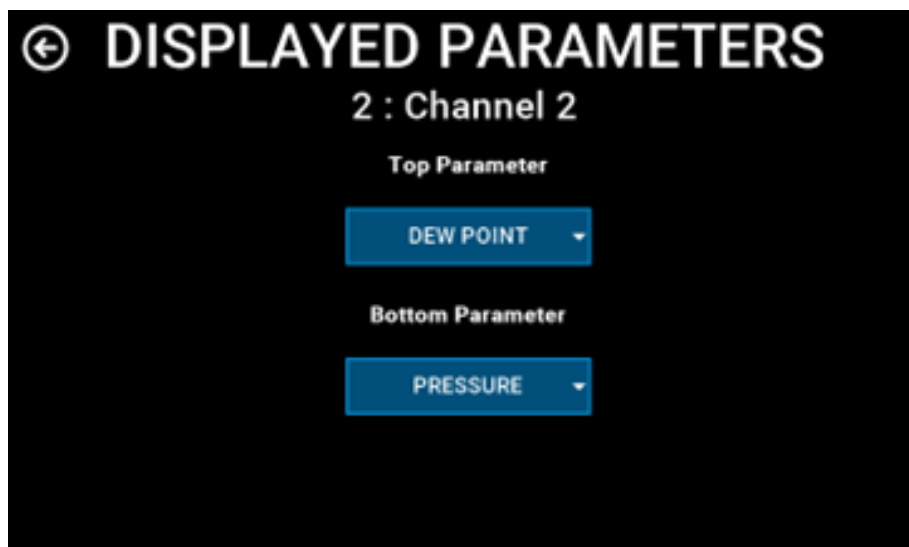

Figure 33 Displayed Parameters Screen for the Gas Channel

### 3.3.3 Oxygen Channel

The channel setup menu for an oxygen-type channel is shown below.

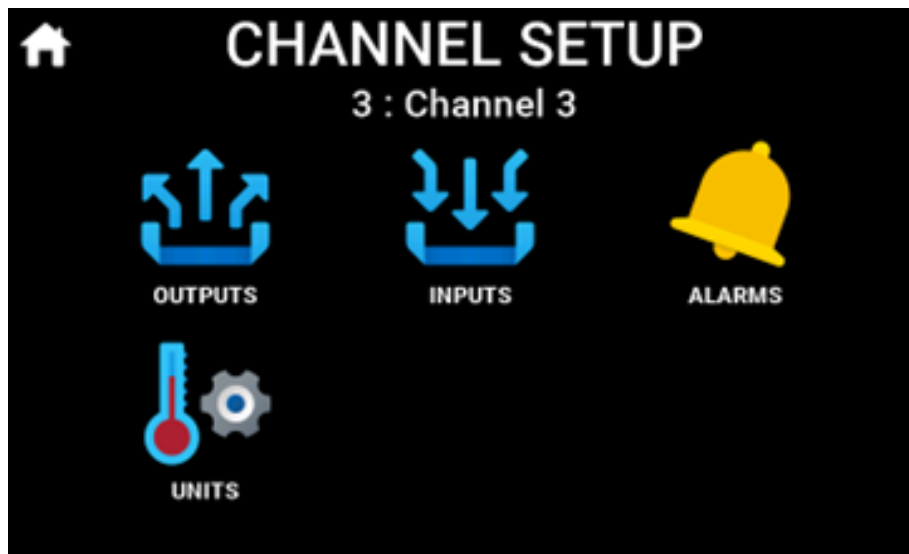

Figure 34 *Oxygen Channel Setup Screen*

The channel setup menu provides access to main channel configuration screens.

#### 3.3.3.1 Oxygen Channel: Outputs

The Outputs screen allows the user to read and edit settings for the three outputs associated with the channel.

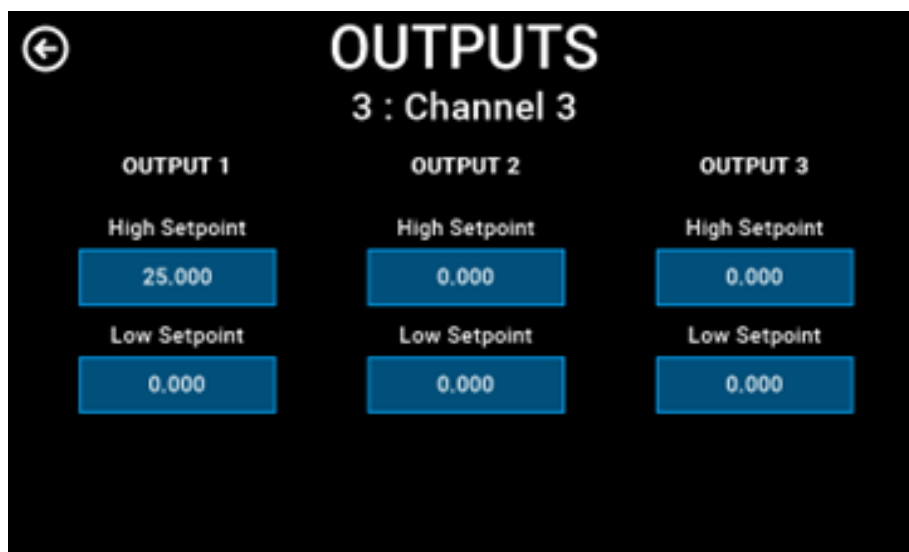

Figure 35 *Outputs Screen for the Oxygen Channel*

### 3.3.3.2 Oxygen Channel: Inputs

The Inputs screen allows the user to read and edit the oxygen input range.

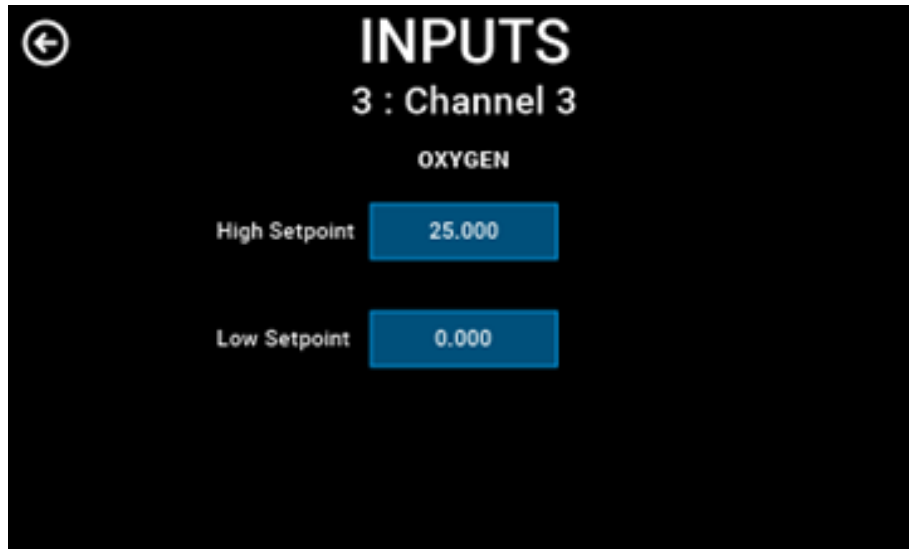

Figure 36 *Inputs Screen for the Oxygen Channel*

### 3.3.3.3 Oxygen Channel: Alarms

The Alarms screen allows the user to read and edit settings for the two alarms associated with the channel.

Additional information includes the effect the channel has on the system (global) alarm.

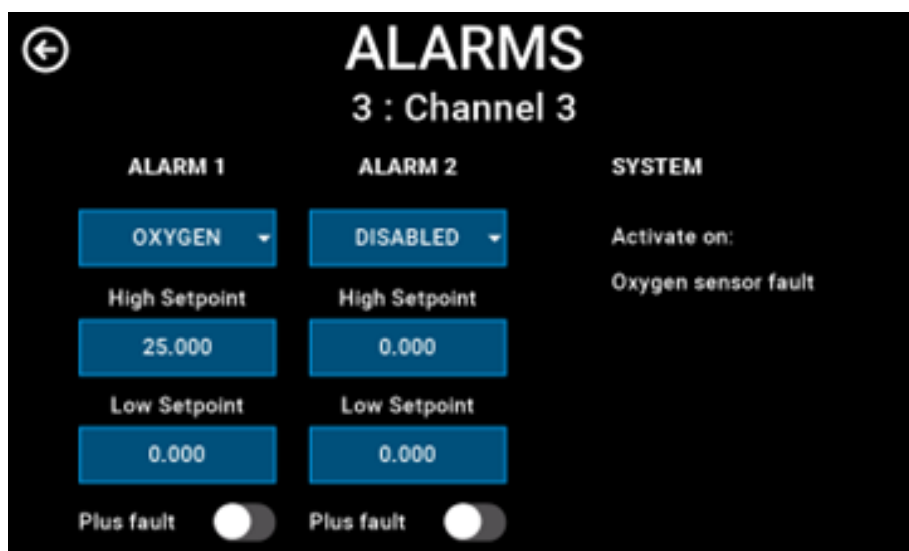

Figure 37 *Alarms Screen for the Oxygen Channel*

The alarm type may be set to Oxygen or Disabled.

### 3.3.3.4 Oxygen Channel: Units

The Units screen allows the user to change the oxygen units.

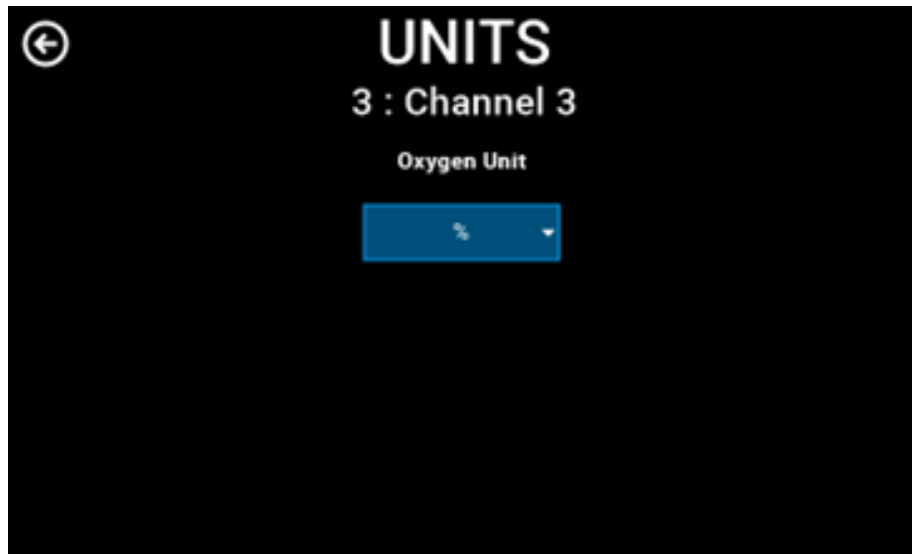

Figure 38 *Units Screen for the Oxygen Channel*



# Appendix A

## Technical Specifications

Appendix A Technical Specifications

Process Monitor	
Display	7" color touchscreen LCD, displaying moisture content / dew point or O <sub>2</sub> and analysis pressure or temperature and process tag names/ numbers
Analog Output	Three 4...20 mA (max load 500 Ω) per channel User configured for parameter, unit and range
Digital Output	RS485 Modbus RTU and Modbus TCP/IP
Data Logging	SD card (Max. 32Gb FAT16/FAT32) All measurement parameters (DP, temperature, pressure, %/ppm O <sub>2</sub> , plus basic fault-finding data
Display Mode	Moisture content (ppm <sub>v</sub> ) Moisture content in natural gas (ppm <sub>v</sub> , lb/MMscf, mg/m <sup>3</sup> ) Dew point (°C or °F) Pressure (psig, barg) % or ppm <sub>v</sub> O <sub>2</sub>
Pressure Compensation	Fixed value (user programmed) or dynamic input from optional pressure sensor
Display Resolution	0.1 °Cdp, 0.1 °Fdp, 0.1...0.001 ppm <sub>v</sub> ideal gas (adjustable), 0.01 ppm <sub>v</sub> natural gas, 0.01 mg/m <sup>3</sup> , 0.01 lb/MMscf, 1 psig, 0.1 barg, 0.01 % / 0.5 ppm <sub>v</sub> O <sub>2</sub>
Alarms	Two alarm relays per channel, with additional system alarm Control action and set point are user-programmable Two Form C contacts rated 30 V DC, 5A Non-inductive load
I.S. Barriers	Galvanic isolation type, integrated to process monitor
Power Supply	85...264 V AC, 47/63 Hz or 20...28 V DC 30 V A maximum power consumption
Operating Environment	Indoor, safe area, 0...+50 °C (+32...+122 °F) < 90 %rh
Interconnection Cable	General instrument type, twisted pair, screened, single pair (two pairs with pressure sensor)
Enclosure	19" sub rack unit Dimensions: 132 x 483 x 375 mm (5 x 19 x 14.75") (h x w x d) (100 mm/4" minimum rear clearance depth for cables and vents)
Sampling Systems	
Refer to relevant ES70 Datasheet (97550)	

A.1 Dimensional Drawings

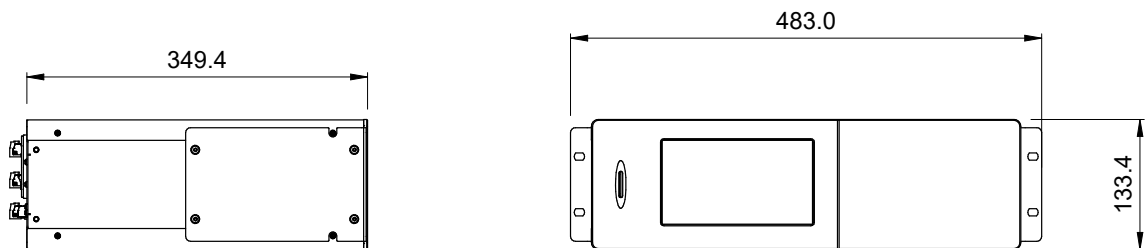

Figure 39 Dimensional Drawings (in mm)

# Appendix B

## Modbus RTU and TCP Communications

## Appendix B Modbus RTU and TCP Communications

### Communicating with the MCPM via Modbus RTU / RS485 serial:

- Serial settings:
- Baud = 9600, data bits = 8, parity = none, stop bits = 1
- Connect to the MCPM RS485 serial port using the wiring below:

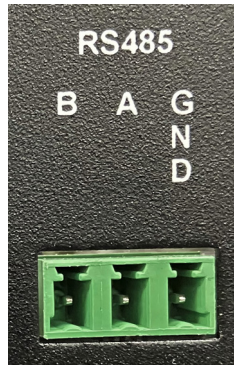

- Set the Modbus address of the MCPM via the Communications screen of the MCPM.
- The Modbus register map can be found in the next section.

### Communicating with the MCPM via Modbus TCP:

- Connect the MCPM to the local network via the Ethernet port as shown below:

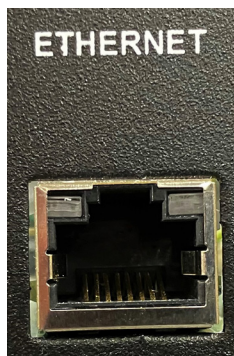

- Read and edit the TCP settings (IP address, subnet mask & default gateway) via the Communications screen of the MCPM.
- The Modbus register map can be found in the next section.

## Process Monitor Register Map:

Address	Access	Lock Level	Data Type	Name	Max	Min	Default
<b>Instrument Information</b>							
0	R W F1	0	uint16	Modbus_address	255	1	1
1	R	0	uint16	Instrument_id	42260	42260	42260
2	R	0	uint32	Instrument_serial_ms	4294967295	0	0
3	R	0		Instrument_serial_ls			
4	R	0	uint16	Instrument_firmware_version	65535	0	X
				Version * 1000 (1012 = 1.012)			
5	R	0	uint16	Register_map_version	65535	0	X
6	R	0	uint16	Channel_1_and_2_firmware_version	65535	0	X
				Version * 1000 (1012 = 1.012)			
7	R	0	uint16	Channel_3_and_4_firmware_version	65535	0	X
				Version * 1000 (1012 = 1.012)			
8	R	0	uint16	Channel_5_and_6_firmware_version	65535	0	X
				Version * 1000 (1012 = 1.012)			
<b>Live Instrument Information</b>							
20	R	0	flags	System_status	65535	0	X
				"32768 = System alarm 8192 = ch6 comms error 4096 = ch5 comms error 2048 = ch4 comms error 1024 = ch3 comms error 512 = ch2 comms error 256 = ch1 comms error 32 = ch6 fault 16 = ch5 fault 8 = ch4 fault 4 =ch3 fault 2 = ch2 fault 1 = ch1 fault"			
21	R	0	flags	Alarm_status	65535	0	X

Address	Access	Lock Level	Data Type	Name	Max	Min	Default
				"8192 = Ch6 alarm 2 4096 = ch5 alarm 2 2048 = ch4 alarm 2 1024 = ch3 alarm 2 512 = ch2 alarm 2 256 = ch1 alarm 2 32 = ch6 alarm 1 16 = ch5 alarm 1 8 = ch4 alarm 1 4 = ch3 alarm 1 2 = ch2 alarm 1 1 = ch1 alarm 1"			
22	R	0	uint16	Log_status	2	0	X
				"0 = No card 1 = mounting 2 = ready 3 = write protected 4 = writing header 5 = logging 6 = writing log 7 = mount error 8 = write error"			
23	R	0	uint16	Eth_status	2	0	
				"0 = Error / not fitted 1 = ok 2 = configuring"			
50	R	0	uint16	Ch1_parameter_1	9	0	0
				"0 = Disabled 1 = dewpoint 2 = ppmv(n) (natural gas) 3 = ppmv(i) (ideal gas) 4 = lbmmscf (absolute humidity) 5 = mg/m <sup>3</sup> (absolute humidity) 6 = pressure 7 = oxygen 8 = ppmw (moisture content) 9 = temperature"			
51	R	0	uint16	Ch1_parameter_2	9	0	0
				"=Parameter"			
				Reserved_for_display_config			
53	R	0	flags	Ch1_status	32768	0	X

Address	Access	Lock Level	Data Type	Name	Max	Min	Default
				"32768 = Non-volatile storage checksum error 1024 = alarm 2 disabled 512 = alarm 2 activated 256 = alarm 1 disabled 128 = alarm 1 activated 64 = output 3 invalid 32 = output 2 invalid 16 = output 1 invalid 8 = input 3 fault (oxygen) 4 = input 2 fault (temp/pressure) 2 = input 1 fault (dp) 1 = channel fault"			
				Reserved_for_additional_status			
55	R	0	bits	Ch1_calc_config	65535	0	X
				"Bits 0-2 = 3 bit number = instrument type bits 3-5 = 3 bit number = table type bits 6-10 = 6 bit number = liquid type bit 11 = 1 bit number = 3rd input enabled"			
				Reserved_for_additional_calc			
57	R	0	bits	Ch1_units	65535	0	X
				"Bits 0-2 = 3 bit number = temperature unit bits 3-6 = 4 bit number = pressure unit bits 7-8 = 2 bit number = oxygen unit"			
				Reserved_for_additional_units			
59	R	0	float	Ch1_dewpoint_ms			X
60	R	0		Ch1_dewpoint_ls			
61	R	0	float	Ch1_ppmv_n_ms			X
62	R	0		Ch1_ppmv_n_ls			
63	R	0	float	Ch1_ppmv_i_ms			X
64	R	0		Ch1_ppmv_i_ls			
65	R	0	float	Ch1_lbmmscf_ms			X
66	R	0		Ch1_lbmmscf_ls			
67	R	0	float	Ch1_mgm3_ms			X

Address	Access	Lock Level	Data Type	Name	Max	Min	Default
68	R	0		Ch1_mgm3_ls			
69	R	0	float	Ch1_pressure_ms			X
70	R	0		Ch1_pressure_ls			
71	R	0	float	Ch1_oxygen_ms			X
72	R	0		Ch1_oxygen_ls			
73	R	0	float	Ch1_ppmw_ms			X
74	R	0		Ch1_ppmw_ls			
75	R	0	float	Ch1_temperature_ms			X
76	R	0		Ch1_temperature_ls			
				Reserved_for_additional_parameters			
<b>Displayed Information – Channel 2</b>							
88	R	0	uint16	Ch2_parameter_1	9	0	0
				"0 = Disabled 1 = dewpoint 2 = ppmv(n) (natural gas) 3 = ppmv(i) (ideal gas) 4 = lbmmscf (absolute humidity) 5 = mg/m <sup>3</sup> (absolute humidity) 6 = pressure 7 = oxygen 8 = ppmw (moisture content) 9 = temperature"			
89	R	0	uint16	Ch2_parameter_2	9	0	0
				"=Parameter"			
				Reserved_for_display_config			
91	R	0	flags	Ch2_status	32768	0	X
				"32768 = Non-volatile storage checksum error 1024 = alarm 2 disabled 512 = alarm 2 activated 256 = alarm 1 disabled 128 = alarm 1 activated 64 = output 3 invalid 32 = output 2 invalid 16 = output 1 invalid 8 = input 3 fault (oxygen) 4 = input 2 fault (temp/pressure) 2 = input 1 fault (dp) 1 = channel fault"			



Address	Access	Lock Level	Data Type	Name	Max	Min	Default
				Reserved_for_additional_status			
93	R	0	bits	Ch2_calc_config	65535	0	X
				"Bits 0-2 = 3 bit number = instrument type bits 3-5 = 3 bit number = table type bits 6-10 = 6 bit number = liquid type bit 11 = 1 bit number = 3rd input enabled"			
				Reserved_for_additional_calc			
95	R	0	flags	Ch2_units	65535	0	X
				"Bits 0-2 = 3 bit number = temperature unit bits 3-6 = 4 bit number = pressure unit bits 7-8 = 2 bit number = oxygen unit"			
				Reserved_for_additional_units			
97	R	0	float	Ch2_dewpoint_ms			X
98	R	0		Ch2_dewpoint_ls			
99	R	0	float	Ch2_ppmv_n_ms			X
100	R	0		Ch2_ppmv_n_ls			
101	R	0	float	Ch2_ppmv_i_ms			X
102	R	0		Ch2_ppmv_i_ls			
103	R	0	float	Ch2_lbmmscf_ms			X
104	R	0		Ch2_lbmmscf_ls			
105	R	0	float	Ch2_mgm3_ms			X
106	R	0		Ch2_mgm3_ls			
107	R	0	float	Ch2_pressure_ms			X
108	R	0		Ch2_pressure_ls			
109	R	0	float	Ch2_oxygen_ms			X
110	R	0		Ch2_oxygen_ls			
111	R	0	float	Ch2_ppmw_ms			X
112	R	0		Ch2_ppmw_ls			
113	R	0	float	Ch2_temperature_ms			X
114	R	0		Ch2_temperature_ls			
				Reserved_for_additional_parameters			

Address	Access	Lock Level	Data Type	Name	Max	Min	Default
<b>Displayed Information – Channel 3</b>							
126	R	0	uint16	Ch3_parameter_1	9	0	0
				"0 = Disabled 1 = dewpoint 2 = ppmv(n) (natural gas) 3 = ppmv(i) (ideal gas) 4 = lbmmscf (absolute humidity) 5 = mg/m <sup>3</sup> (absolute humidity) 6 = pressure 7 = oxygen 8 = ppmw (moisture content) 9 = temperature"			
127	R	0	uint16	Ch3_parameter_2	9	0	0
				"=Parameter"			
				Reserved_for_display_config			
129	R	0	flags	Ch3_status	32768	0	X
				"32768 = Non-volatile storage checksum error 1024 = alarm 2 disabled 512 = alarm 2 activated 256 = alarm 1 disabled 128 = alarm 1 activated 64 = output 3 invalid 32 = output 2 invalid 16 = output 1 invalid 8 = input 3 fault (oxygen) 4 = input 2 fault (temp/pressure) 2 = input 1 fault (dp) 1 = channel fault"			
				Reserved_for_additional_status			
131	R	0	bits	Ch3_calc_config	65535	0	X
				"Bits 0-2 = 3 bit number = instrument type bits 3-5 = 3 bit number = table type bits 6-10 = 6 bit number = liquid type bit 11 = 1 bit number = 3rd input enabled"			
				Reserved_for_additional_calc			
133	R	0	flags	Ch3_units	65535	0	X

Address	Access	Lock Level	Data Type	Name	Max	Min	Default
				"Bits 0-2 = 3 bit number = temperature unit bits 3-6 = 4 bit number = pressure unit bits 7-8 = 2 bit number = oxygen unit"			
				Reserved_for_additional_units			
135	R	0	float	Ch3_dewpoint_ms			X
136	R	0		Ch3_dewpoint_ls			
137	R	0	float	Ch3_ppmv_n_ms			X
138	R	0		Ch3_ppmv_n_ls			
139	R	0	float	Ch3_ppmv_i_ms			X
140	R	0		Ch3_ppmv_i_ls			
141	R	0	float	Ch3_lbmmscf_ms			X
142	R	0		Ch3_lbmmscf_ls			
143	R	0	float	Ch3_mgm3_ms			X
144	R	0		Ch3_mgm3_ls			
145	R	0	float	Ch3_pressure_ms			X
146	R	0		Ch3_pressure_ls			
147	R	0	float	Ch3_oxygen_ms			X
148	R	0		Ch3_oxygen_ls			
149	R	0	float	Ch3_ppmw_ms			X
150	R	0		Ch3_ppmw_ls			
151	R	0	float	Ch3_temperature_ms			X
152	R	0		Ch3_temperature_ls			
				Reserved_for_additional_parameters			
<b>Displayed Information – Channel 4</b>							
164	R	0	uint16	Ch4_parameter_1	9	0	0

Address	Access	Lock Level	Data Type	Name	Max	Min	Default
				"0 = Disabled 1 = dewpoint 2 = ppmv(n) (natural gas) 3 = ppmv(i) (ideal gas) 4 = lbmmscf (absolute humidity) 5 = mg/m <sup>3</sup> (absolute humidity) 6 = pressure 7 = oxygen 8 = ppmw (moisture content) 9 = temperature"			
165	R	0	uint16	Ch4_parameter_2	9	0	0
				"=Parameter"			
				Reserved_for_display_config			
167	R	0	flags	Ch4_status	32768	0	X
				"32768 = Non-volatile storage checksum error 1024 = alarm 2 disabled 512 = alarm 2 activated 256 = alarm 1 disabled 128 = alarm 1 activated 64 = output 3 invalid 32 = output 2 invalid 16 = output 1 invalid 8 = input 3 fault (oxygen) 4 = input 2 fault (temp/pressure) 2 = input 1 fault (dp) 1 = channel fault"			
				Reserved_for_additional_status			
169	R	0	bits	Ch4_calc_config	65535	0	X
				"Bits 0-2 = 3 bit number = instrument type bits 3-5 = 3 bit number = table type bits 6-10 = 6 bit number = liquid type bit 11 = 1 bit number = 3rd input enabled"			
				Reserved_for_additional_calc			
171	R	0	flags	Ch4_units	65535	0	X

Address	Access	Lock Level	Data Type	Name	Max	Min	Default
				"Bits 0-2 = 3 bit number = temperature unit bits 3-6 = 4 bit number = pressure unit bits 7-8 = 2 bit number = oxygen unit"			
				Reserved_for_additional_units			
173	R	0	float	Ch4_dewpoint_ms			X
174	R	0		Ch4_dewpoint_ls			
175	R	0	float	Ch4_ppmv_n_ms			X
176	R	0		Ch4_ppmv_n_ls			
177	R	0	float	Ch4_ppmv_i_ms			X
178	R	0		Ch4_ppmv_i_ls			
179	R	0	float	Ch4_lbmmscf_ms			X
180	R	0		Ch4_lbmmscf_ls			
181	R	0	float	Ch4_mgm3_ms			X
182	R	0		Ch4_mgm3_ls			
183	R	0	float	Ch4_pressure_ms			X
184	R	0		Ch4_pressure_ls			
185	R	0	float	Ch4_oxygen_ms			X
186	R	0		Ch4_oxygen_ls			
187	R	0	float	Ch4_ppmw_ms			X
188	R	0		Ch4_ppmw_ls			
189	R	0	float	Ch4_temperature_ms			X
190	R	0		Ch4_temperature_ls			
				Reserved_for_additional_parameters			
<b>Displayed Information – Channel 5</b>							
202	R	0	uint16	Ch5_parameter_1	9	0	0

Address	Access	Lock Level	Data Type	Name	Max	Min	Default
				"0 = Disabled 1 = dewpoint 2 = ppmv(n) (natural gas) 3 = ppmv(i) (ideal gas) 4 = lbmmscf (absolute humidity) 5 = mg/m <sup>3</sup> (absolute humidity) 6 = pressure 7 = oxygen 8 = ppmw (moisture content) 9 = temperature"			
203	R	0	uint16	Ch5_parameter_2	9	0	0
				"=Parameter"			
				Reserved_for_display_config			
205	R	0	flags	Ch5_status	32768	0	X
				"32768 = Non-volatile storage checksum error 1024 = alarm 2 disabled 512 = alarm 2 activated 256 = alarm 1 disabled 128 = alarm 1 activated 64 = output 3 invalid 32 = output 2 invalid 16 = output 1 invalid 8 = input 3 fault (oxygen) 4 = input 2 fault (temp/pressure) 2 = input 1 fault (dp) 1 = channel fault"			
				Reserved_for_additional_status			
207	R	0	bits	Ch5_calc_config	65535	0	X
				"Bits 0-2 = 3 bit number = instrument type bits 3-5 = 3 bit number = table type bits 6-10 = 6 bit number = liquid type bit 11 = 1 bit number = 3rd input enabled"			
				Reserved_for_additional_calc			
209	R	0	flags	Ch5_units	65535	0	X

Address	Access	Lock Level	Data Type	Name	Max	Min	Default
				"Bits 0-2 = 3 bit number = temperature unit bits 3-6 = 4 bit number = pressure unit bits 7-8 = 2 bit number = oxygen unit"			
				Reserved_for_additional_units			
211	R	0	float	Ch5_dewpoint_ms			X
212	R	0		Ch5_dewpoint_ls			
213	R	0	float	Ch5_ppmv_n_ms			X
214	R	0		Ch5_ppmv_n_ls			
215	R	0	float	Ch5_ppmv_i_ms			X
216	R	0		Ch5_ppmv_i_ls			
217	R	0	float	Ch5_lbmmscf_ms			X
218	R	0		Ch5_lbmmscf_ls			
219	R	0	float	Ch5_mgm3_ms			X
220	R	0		Ch5_mgm3_ls			
221	R	0	float	Ch5_pressure_ms			X
222	R	0		Ch5_pressure_ls			
223	R	0	float	Ch5_oxygen_ms			X
224	R	0		Ch5_oxygen_ls			
225	R	0	float	Ch5_ppmw_ms			X
226	R	0		Ch5_ppmw_ls			
227	R	0	float	Ch5_temperature_ms			X
228	R	0		Ch5_temperature_ls			
				Reserved_for_additional_parameters			
<b>Displayed Information – Channel 6</b>							
240	R	0	uint16	Ch6_parameter_1	9	0	0

Address	Access	Lock Level	Data Type	Name	Max	Min	Default
				"0 = Disabled 1 = dewpoint 2 = ppmv(n) (natural gas) 3 = ppmv(i) (ideal gas) 4 = lbmmscf (absolute humidity) 5 = mg/m <sup>3</sup> (absolute humidity) 6 = pressure 7 = oxygen 8 = ppmw (moisture content) 9 = temperature"			
241	R	0	uint16	Ch6_parameter_2	9	0	0
				"=Parameter"			
				Reserved_for_display_config			
243	R	0	flags	Ch6_status	32768	0	X
				"32768 = Non-volatile storage checksum error 1024 = alarm 2 disabled 512 = alarm 2 activated 256 = alarm 1 disabled 128 = alarm 1 activated 64 = output 3 invalid 32 = output 2 invalid 16 = output 1 invalid 8 = input 3 fault (oxygen) 4 = input 2 fault (temp/pressure) 2 = input 1 fault (dp) 1 = channel fault"			
				Reserved_for_additional_status			
245	R	0	bits	Ch6_calc_config	65535	0	X
				"Bits 0-2 = 3 bit number = instrument type bits 3-5 = 3 bit number = table type bits 6-10 = 6 bit number = liquid type bit 11 = 1 bit number = 3rd input enabled"			
				Reserved_for_additional_calc			
247	R	0	flags	Ch6_units	65535	0	X



Address	Access	Lock Level	Data Type	Name	Max	Min	Default
				"Bits 0-2 = 3 bit number = temperature unit bits 3-6 = 4 bit number = pressure unit bits 7-8 = 2 bit number = oxygen unit"			
				Reserved_for_additional_units			
249	R	0	float	Ch6_dewpoint_ms			X
250	R	0		Ch6_dewpoint_ls			
251	R	0	float	Ch6_ppmv_n_ms			X
252	R	0		Ch6_ppmv_n_ls			
253	R	0	float	Ch6_ppmv_i_ms			X
254	R	0		Ch6_ppmv_i_ls			
255	R	0	float	Ch6_lbmmscf_ms			X
256	R	0		Ch6_lbmmscf_ls			
257	R	0	float	Ch6_mgm3_ms			X
258	R	0		Ch6_mgm3_ls			
259	R	0	float	Ch6_pressure_ms			X
260	R	0		Ch6_pressure_ls			
261	R	0	float	Ch6_oxygen_ms			X
262	R	0		Ch6_oxygen_ls			
263	R	0	float	Ch6_ppmw_ms			X
264	R	0		Ch6_ppmw_ls			
265	R	0	float	Ch6_temperature_ms			X
266	R	0		Ch6_temperature_ls			
				Reserved_for_additional_parameters			
<b>Overall Configuration</b>							
500	R W F1	0	uint16	Channel_count	1	0	0
				"0 = 4 Channel 1 = 6 channel"			
501	R W F1	0	flags	Reserved (enabled_channels)	63	0	15
				"0 = No channels 1 = channel 1 2 = channel 2 4 = channel 3 8 = channel 4 16 = channel 5 32 = channel 6"			

Address	Access	Lock Level	Data Type	Name	Max	Min	Default
<b>System Alarm Settings</b>							
510	R W F1	0	flags	Sys_alm_ch_fault_enable			X
				"0 = No channels 1 = channel 1 2 = channel 2 4 = channel 3 8 = channel 4 16 = channel 5 32 = channel 6"			
511	R W F1	0	flags	Reserved - sys_alm_ch_alarm1_enable			X
				"0 = No channels 1 = channel 1 2 = channel 2 4 = channel 3 8 = channel 4 16 = channel 5 32 = channel 6"			
512	R W F1	0	flags	Reserved - sys_alm_ch_alarm2_enable			X
				"0 = No channels 1 = channel 1 2 = channel 2 4 = channel 3 8 = channel 4 16 = channel 5 32 = channel 6"			
<b>Time &amp; Date</b>							
520	R W	0	uint16	Rtc_year	99	21	N/A
521	R W	0	uint16	Rtc_month	12	1	N/A
522	R W	0	uint16	Rtc_day	31	1	N/A
523	R W	0	uint16	Rtc_hours	24	0	N/A
524	R W	0	uint16	Rtc_minutes	59	0	N/A
525	R W	0	uint16	Rtc_seconds	59	0	N/A
<b>Display Settings</b>							
530	R W F1	0	uint16	Display_brightness	100	10	80
<b>Network Settings – Ethernet</b>							
540	R	0	uint16	Eth_status	2	0	
				"0 = Error / not fitted 1 = ok 2 = configuring"			
541	R W F	0	uint16	Eth_ip_1	255	0	
542	R W F	0	uint16	Eth_ip_2	255	0	

Address	Access	Lock Level	Data Type	Name	Max	Min	Default
543	R W F	0	uint16	Eth_ip_3	255	0	
544	R W F	0	uint16	Eth_ip_4	255	0	
545	R W F	0	uint16	Eth_subnet_1	255	0	
546	R W F	0	uint16	Eth_subnet_2	255	0	
547	R W F	0	uint16	Eth_subnet_3	255	0	
548	R W F	0	uint16	Eth_subnet_4	255	0	
549	R W F	0	uint16	Eth_gateway_1	255	0	
550	R W F	0	uint16	Eth_gateway_2	255	0	
551	R W F	0	uint16	Eth_gateway_3	255	0	
552	R W F	0	uint16	Eth_gateway_4	255	0	

# Appendix C

## Quality, Recycling, Compliance & Warranty Information

**Appendix C      Quality, Recycling, Compliance & Warranty Information**

Michell Instruments is dedicated to complying to all relevant legislation and directives. Full information can be found on our website at:

**[www.ProcessSensing.com/en-us/compliance](http://www.ProcessSensing.com/en-us/compliance)**

This page contains information on the following directives:

- Anti-Facilitation of Tax Evasion Policy
- ATEX Directive
- Calibration Facilities
- Conflict Minerals
- FCC Statement
- Manufacturing Quality
- Pressure Equipment Directive
- REACH
- RoHS3
- WEEE2
- Recycling Policy
- Warranty and Returns

This information is also available in PDF format.

# Appendix D

## Return Document & Decontamination Declaration

## Appendix D Return Document &amp; Decontamination Declaration

## Decontamination Certificate

**IMPORTANT NOTE: Please complete this form prior to this instrument, or any components, leaving your site and being returned to us, or, where applicable, prior to any work being carried out by a Michell engineer at your site.**

Instrument			Serial Number	
Warranty Repair?	YES	NO	Original PO #	
Company Name			Contact Name	
Address				
Telephone #			E-mail address	
Reason for Return /Description of Fault:				
Has this equipment been exposed (internally or externally) to any of the following? Please circle (YES/NO) as applicable and provide details below				
Biohazards			YES	NO
Biological agents			YES	NO
Hazardous chemicals			YES	NO
Radioactive substances			YES	NO
Other hazards			YES	NO
Please provide details of any hazardous materials used with this equipment as indicated above (use continuation sheet if necessary)				
Your method of cleaning/decontamination				
Has the equipment been cleaned and decontaminated?			YES	NOT NECESSARY
Michell Instruments will not accept instruments that have been exposed to toxins, radio-activity or bio-hazardous materials. For most applications involving solvents, acidic, basic, flammable or toxic gases a simple purge with dry gas (dew point <-30°C) over 24 hours should be sufficient to decontaminate the unit prior to return. <b>Work will not be carried out on any unit that does not have a completed decontamination declaration.</b>				
<b>Decontamination Declaration</b>				
I declare that the information above is true and complete to the best of my knowledge, and it is safe for Michell personnel to service or repair the returned instrument.				
Name (Print)			Position	
Signature			Date	



[www.ProcessSensing.com](http://www.ProcessSensing.com)