

# Promet I.S. Process Moisture Analyzer User Manual



Please fill out the form(s) below for each instrument that has been purchased.

Use this information when contacting Michell Instruments for service purposes.

Product Name	
Order Code	
Serial Number	
Invoice Date	
Installation Location	
Tag Number	

Product Name	
Order Code	
Serial Number	
Invoice Date	
Installation Location	
Tag Number	

Product Name	
Order Code	
Serial Number	
Invoice Date	
Installation Location	
Tag Number	



## Promet I.S. Process Moisture Analyzer

For Michell Instruments' contact information please go to  
[www.ProcessSensing.com](http://www.ProcessSensing.com)

© 2024 Michell Instruments

This document is the property of Michell Instruments Ltd and may not be copied or otherwise reproduced, communicated in any way to third parties, nor stored in any Data Processing System without the express written authorization of Michell Instruments Ltd.

---

## Contents

Safety .....	vi
Electrical Safety .....	vii
Pressure Safety .....	vii
Hazardous Materials (WEEE, RoHS3 & REACH) .....	vii
Repair and Maintenance .....	vii
Calibration .....	vii
Safety Conformity .....	vii
Abbreviations .....	viii
1 INTRODUCTION .....	1
1.1 Performance Features .....	2
1.2 Applications .....	2
1.3 Theory of Operation .....	3
1.4 System Components .....	4
1.4.1 Input/Output Signal .....	5
1.5 Sampling System .....	5
2 INSTALLATION .....	6
2.1 Unpacking the Analyzer .....	6
2.2 Environmental Requirements .....	7
2.3 Mounting .....	7
2.3.1 Control Unit Installation .....	7
2.3.2 Mounting the Promet I.S. Sensor Assembly into the Sampling System .....	9
2.3.3 Sampling System Installation .....	11
2.4 Wiring .....	12
2.4.1 Overall Wiring Arrangement .....	12
2.4.2 Control Unit Wiring .....	13
2.4.2.1 Power Supply Input Connection .....	14
2.4.2.2 Sensor Signal Input Connection .....	16
2.4.2.3 Analog Output Connection .....	17
2.4.2.4 Alarm Output Connection .....	18
2.4.2.5 RS485 Port Connection .....	19
2.4.3 Sensor Assembly Wiring .....	20
2.4.3.1 Dew-point Transmitter Wiring .....	20
2.4.3.2 Optional Pressure Transmitter Wiring .....	23
3 OPERATION .....	26
3.1 Preparation .....	26
3.2 Start-Up .....	26
3.2.1 Main Display .....	26
3.2.2 Setup Menu .....	27
3.3 Menu Structure .....	30

## Figures

Figure 1	Promet I.S. Control Unit.....	1
Figure 2	Structure of the Michell Ceramic Metal-Oxide Moisture Sensor .....	3
Figure 3	Major Components of the Promet I.S. ....	4
Figure 4	Dimensions of the Control Unit (in mm) .....	7
Figure 5	Rack Mounting Method .....	8
Figure 6	Promet I.S. Sensor Assembly.....	9
Figure 7	Overall Wiring Arrangement .....	12
Figure 8	Control Unit Electrical Connections.....	13
Figure 9	POWER INPUT Socket.....	14
Figure 10	POWER INPUT Connector Block.....	15
Figure 11	SENSOR INPUTS Connector Block.....	16
Figure 12	ALARM Connector Block .....	18
Figure 13	Crimped Wires .....	21
Figure 14	Cut to 5 mm .....	21
Figure 15	Dew-point Transmitter Housing .....	21
Figure 16	Pin Assignment Drawing .....	22
Figure 17	Pressure Transmitter Connector.....	23
Figure 18	Removal of Terminal Block .....	24
Figure 19	Pressure Transmitter Wiring Diagram .....	25
Figure 20	Menu Map.....	31
Figure 21	Dimensional Drawings (in mm).....	34

## Appendices

Appendix A	Technical Specifications.....	33
	A.1 Dimensional Drawings.....	34
Appendix B	Serial Communications.....	36
Appendix C	Hazardous Area Certification .....	47
	C.1 ATEX/UKCA .....	47
	C.2 IECEX .....	47
	C.3 North American (cQPSus).....	47
	C.4 Terminal Parameters .....	48
	C.5 Special Conditions.....	48
	C.6 Maintenance and Installation .....	48
Appendix D	System Drawings.....	50
	D.1 Baseefa Approved System Drawing .....	50
	D.2 QPS Approved System Drawing.....	51
Appendix E	Quality, Recycling & Warranty Information.....	53
Appendix F	Return Document & Decontamination Declaration .....	55

## Safety

The instrument is designed to be completely safe when installed and operated correctly in accordance with the information provided in this manual.

This manual contains all the required information to install, operate and maintain this product. Prior to installation and use of this product, this entire manual should be read and understood. Installation and operation of this product should be carried out by suitably competent personnel only. The installation and operation of this product must be in accordance with the instructions provided and according to the terms of any associated safety certificates. Incorrect installation and use of this product other than those described in this manual and other than its intended purpose will render all warranties void.

This product meets the essential protection requirements of the relevant EU & UK directives. Further details of applied directives may be found in the product specification.

Electricity and pressurized gas can be dangerous. This product must be installed and operated only by suitable trained personnel.



**No user serviceable parts inside**



**Where this hazard warning symbol appears in the following sections, it is used to indicate areas where potentially hazardous operations need to be carried out and where particular attention to personal and personnel safety must be observed.**



**Where this symbol appears in the following sections it is used to indicate areas of potential risk of electric shock.**

This product is intended for use only under the following conditions:

- a. indoor use
- b. altitude up to 2 000 m
- c. temperature 5 °C...40 °C
- d. maximum relative humidity 80 % for temperatures up to 31 °C decreasing linearly to 50 %, relative humidity at 40 °C
- e. MAINS supply voltage fluctuations up to  $\pm 10$  % of the nominal voltage
- f. TRANSIENT OVERVOLTAGES up to the levels of OVERVOLTAGE CATEGORY II
- g. TEMPORARY OVERVOLTAGES occurring on the MAINS supply
- h. applicable POLLUTION DEGREE 2 of the intended environment

## Electrical Safety

Ensure electrical safety is complied with by following the directions provided here and observing all local operation & installation requirements at the intended location of use.

This product is completely safe when using any options and accessories supplied by the manufacturer of this product for use with it. Refer to Section 2 (Installation) of this manual for further details.

## Pressure Safety

For this product to operate satisfactorily, pressurized gas must be connected to it. Observe all the information contained within this manual and all local operation & installation requirements at the intended location of use. Refer to Section 2 (Installation) of this manual for further details.

## Hazardous Materials (WEEE, RoHS3 & REACH)

This product does not contain or release any prohibited chemicals listed on the SVHC (Substances of Very High Concern) Candidate List. During the intended normal operation of this product it is not possible for the user to come into contact with any hazardous materials. This product is designed to be recyclable except where indicated.

## Repair and Maintenance

The instrument must be maintained either by the manufacturer or an accredited service agent. For contact information visit the website at [www.ProcessSensing.com](http://www.ProcessSensing.com).

## Calibration

Periodic re-calibration is recommended in order to maintain the highest quality of measurement in your application. Michell Instruments recommends that you have your Promet I.S. transmitter re-calibrated annually unless it is used in a mission-critical application or in a contaminated environment, in which case the calibration interval should be reduced accordingly.

Michell Instruments can offer a variety of re-calibration and exchange transmitter schemes to suit your specific needs. A local representative will be pleased to provide detailed custom advice.

## Safety Conformity

This product meets the essential protection requirements of the relevant EU & UK directives. Further details of applied standards may be found in Appendix E.

## Abbreviations

The following abbreviations are used in this manual:

A	Ampere
AC	alternating current
barg	pressure in bar (gauge)
°C	degrees Celsius
°F	degrees Fahrenheit
DC	direct current
dp	dew point
Hz	Hertz
lb/MMscf	pounds per million standard cubic feet
lbf-ft	pound force per foot
mA	milliampere
mg/m <sup>3</sup>	milligrams per cubic meter
mm	millimeters
NI/min	normal liters per minute
ppm <sub>v</sub>	parts per million by volume
psig	pressure in pound(s) per square inch (gauge)
scfh	standard cubic feet per hour
T	temperature
V	Volts
W	Watts
"	inch(es)



## 1 INTRODUCTION

The Promet I.S. Process Moisture Analyzer is a continuous, on-line instrument for the measurement of absolute moisture content in gas. It is designed to fulfil a wide range of applications and provide for the monitoring and/or control of moisture in gas. The instrument consists of two component parts: the control unit and the sensors' assembly (moisture transmitters and optional pressure transmitter). They are individually calibrated to a single standard allowing for total interchangeability between combinations of sensors and control units.

The instrument covers the ranges  $-100...+20$  °Cdp ( $-148...+68$  °Fdp),  $0...9999$  ppm<sub>v</sub>, as well as  $0...1000$  lb/MMscf and  $g/m^3$  for natural gas. Selection of the displayed moisture unit of measure is factory-set but may be easily changed by the user. Four alarm relay contacts are provided which are user-configurable both in terms of set-point and operating mode. Current output is factory set at  $4...20$  mA.

The Promet I.S. performs moisture content calculations based on the measured dew point and the analysis pressure. The default setting of the monitor assumes atmospheric pressure but the customer can set a fixed value of elevated pressure – for this to be a valid method, the sensor must be installed at a constant, known analysis pressure. Alternatively, there is an active pressure compensation option providing a loop-powered intrinsically-safe pressure transmitter connecting to the second input channel on the control unit, for dynamic pressure compensation.

The Promet I.S. Control Unit must be placed in a non-hazardous area suitable for electronic analytical equipment. The moisture transmitter and optional pressure transmitter can be positioned close to the process sample take-off point in a Zone 0, 1 or 2 (Class I, Division 1, Groups A,B,C and D) hazardous area. The control unit and transmitters are connected via a standard 2-wire instrumentation cable protected by safety isolation interface units.



**Figure 1** Promet I.S. Control Unit

## **1.1 Performance Features**

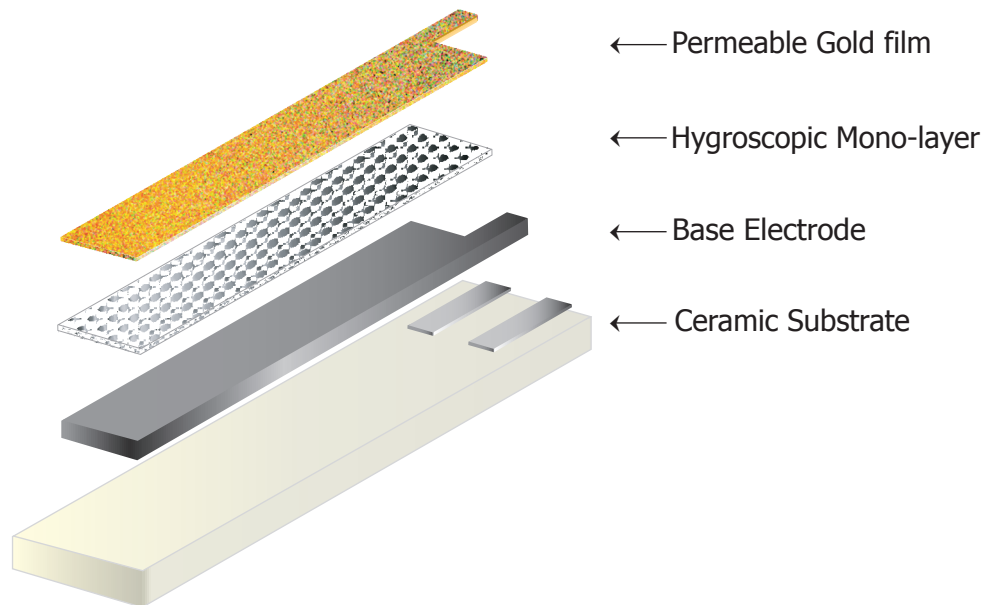
- State-of-the-art ceramic metal-oxide moisture sensor with chemically inert materials coupled with physical resilience provides long-term reliability in the most arduous applications. Robust construction also enables measurement directly at process / pipeline pressure up to 45 MPa (450 barg/5801 psig).
- High integrity moisture measurement from ambient to ppb level with an exhaustive list of hygrometric units, including key parameters of natural gas.
- Three 4...20 mA output with configurable units / ranges. RS485 Modbus RTU communication. Four built-in user-adjustable alarm contacts.
- Assured measurement accuracy with each sensor calibrated across the entire measurement range and certified traceable to NPL (UK) and NIST (USA).
- User-programmable or real-time active pressure compensation for moisture content calculation.
- Certified intrinsically safe.
- Replaceable sensor element with Michell Calibration Exchange Service for professional, scheduled and low cost recalibration to minimize downtime and cost.
- Up to four independent measurement channels with any combination of moisture in gas and moisture in liquid and oxygen measurement at low per-channel cost.
- Customized sampling systems to meet even the most demanding applications.

## **1.2 Applications**

- Natural gas production and processing
- Pipeline drying
- Offshore export pipeline natural gas
- Transmission pipeline monitoring
- Fiscal metering/custody transfer of gas
- Gas storage facilities
- Hydrogen production, storage and transportation including natural gas injection
- LNG production processing and receiving terminals
- Gas generation industries

### 1.3 Theory of Operation

The reliable and robust sensor design is fundamental to achieving accurate measurement of moisture in process over a long period of time. Proprietary thick- and thin-film techniques are applied in the Michell ceramic metal-oxide moisture sensor. The inert materials of the sensor have a high resistance to aggressive media while the inherent strength of the sensor and the thermal bonded connections to the active device ensures reliable operation.



**Figure 2** *Structure of the Michell Ceramic Metal-Oxide Moisture Sensor*

The ceramic metal-oxide moisture sensor responds to the partial pressure of water vapor in the gas being measured, which is directly related to the dew-point temperature.

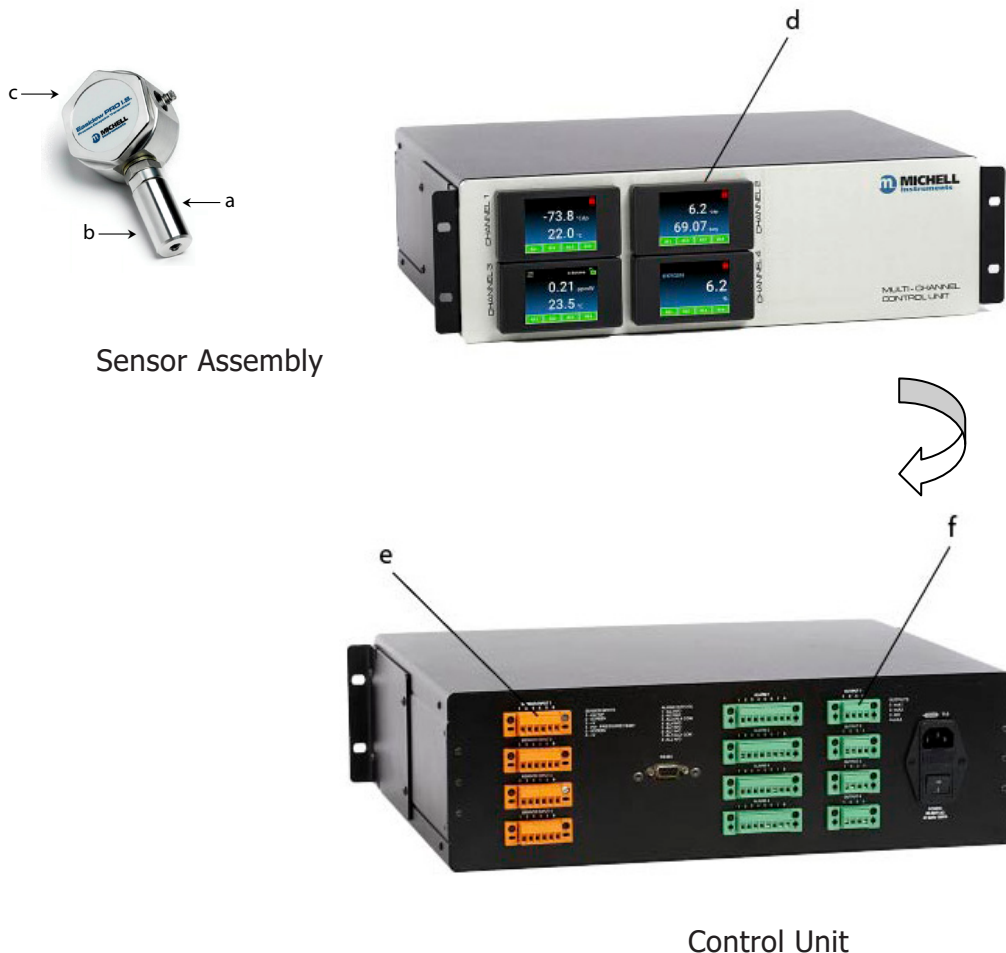
Calibration is certified traceable to NPL (UK) and NIST (USA) through the use of dew-point transfer standards.

The firmware of the Promet I.S. incorporates dew point/pressure to moisture content conversion data for ideal gas and natural gas. The calculation for natural gas uses either the long established IGT research Bulletin No.8 or the more recently published ISO 18453, depending on the customer's preference.

1.4 System Components

The Promet I.S. Process Moisture Analyzer consists of:

- the sensor assembly
- the multi-channel control unit



(Up to four channels can have any combination of Promet I.S., Liquidew I.S. or Minox-i O<sub>2</sub> sensors\*)

a	Port for optional pressure transmitter
b	Sensor block
c	Dew-point transmitter
d	User interface
e	Electrical connections – to hazardous area
f	Electrical connections – to non-hazardous area

**Figure 3** Major Components of the Promet I.S.

\* Liquidew I.S. is a sister product of the Promet I.S. used for moisture in liquid measurement; Minox-i is an electrochemical oxygen sensor

### 1.4.1 Input/Output Signal

The terminal blocks for the signal input, signal output and alarm output are located on the back panel of the control unit (see *Figure 8*).

- **Signal Input**

There are two 4...20 mA signal input channels from the dew-point and optional pressure sensors to the control unit. Both input channels are isolated by built-in galvanic type I.S. barriers. See Appendices A and D for barrier configuration.

- **Signal Output**

There are three 4...20 mA linear signal output channels. Each output can be set for either Dew Point, Pressure, ppm<sub>v</sub>(I), lbmmscf, mg/m<sup>3</sup>, ppm<sub>v</sub>(N) % or ppm<sub>v</sub> O<sub>2</sub>.

There is one RS485 Modbus RTU digital communication port. Refer to Appendix B.

- **Alarm Output**

There are four alarm relays. Alarms 1 and 2 are Form C contacts rated 30 V DC 5A, non-inductive load. Alarms 3 and 4 are Form A contacts rated 30 V DC 5A, non-inductive load. The control actions and set points of these four alarms are user-programmable. A fault alarm with adjustable set points is also included.

## 1.5 Sampling System

The Promet I.S. requires a clean sample of the gas mixture that meets the pressure and flow requirements of the transmitter. The design of the sampling system will depend on the specific application.

The requirements for the sample gas going into the sensor block are as follows:

- Temperature: -40...+60 °C (-40...+140 °F)  
(-20...+40 °C (-4...+104 °F) recommended for optimum performance)
- Maximum pressure: 13 Mpa (130 barg / 1886 psig)
- Flow rate: 1...5 NI/min (2.1...10.6 scfh)

**NOTE: Contact Michell Instruments if you wish to order a specific sampling system.**

Please refer to the ES70G Sampling System manual if a Michell sampling system has been ordered with the Promet I.S.

## 2 INSTALLATION



**DANGER**  
Electric  
Shock Risk

**It is essential that the installation of the electrical and gas supplies to this analyzer be undertaken by suitably qualified personnel.**

### 2.1 Unpacking the Analyzer

Unpack carefully as follows:

- a. Remove the accessories (if ordered).
- b. If no accessories have been ordered the delivery should contain following items:
  - Promet I.S. multi-channel control unit
  - Promet I.S. sensor assembly (if a sampling system has been ordered, the sensor assembly should already be mounted in the sampling system)
  - Certificates of calibration and conformity
  - Power lead (only for 85...265 V AC version)
- c. Remove the Promet I.S. sensor assembly from the box.
- d. Lift out the control unit together with its end packing pieces.
- e. Remove the end packing pieces and set the control unit down at the site of installation. Save all the packing materials for the purpose of returning the instrument to the manufacturer for service.

If ordered, the ES70G Sampling System will be shipped in a separate box.

## 2.2 Environmental Requirements

The Promet I.S. sensor assembly is intrinsically safe and designed to be installed on-site, indoors or outdoors, directly at the point of measurement within a Hazardous Area. The sensor assembly is ATEX, UKCA, IECEx and QPS certified (to be specified at time of order). To operate correctly, the sensor assembly must be installed within a suitable sampling system (Michell Instruments can supply standard and custom designed sampling systems).

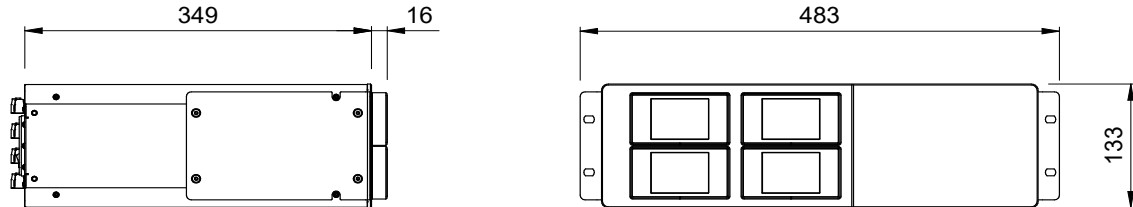
The Promet I.S. control unit is NOT designed for use in a Hazardous Area and should only be installed in a safe area. The control unit is intended for indoor installation only and operates within environmental limits of 0...+50 °C (+32...+122 °F) and <90 %rh. The control unit contains built-in isolation barriers permitting connection, direct from the Hazardous Area, of the Promet I.S. sensor assembly.

## 2.3 Mounting

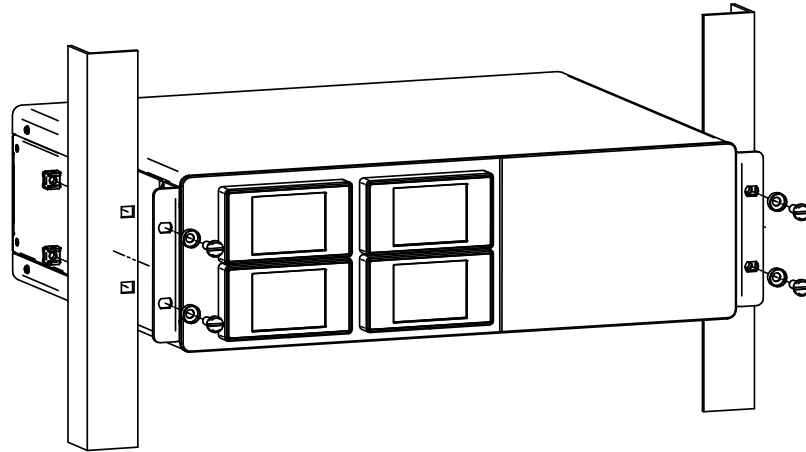
### 2.3.1 Control Unit Installation

The Promet I.S. control unit is contained in a 19" sub-rack case (size 3U). It should be installed in a 19" rack using the mounting holes provided. It should be placed in a position free from any appreciable vibration and shaded from direct sunlight.

**NOTE: The materials and construction of the control unit allow for operation in an indoor, clean, non-hazardous only, control room environment.**



**Figure 4** *Dimensions of the Control Unit (in mm)*



**Figure 5** Rack Mounting Method

Figure 5 illustrates the general method for fitting a rack mount instrument into a standard 19" rack. To fit the unit proceed as follows:

- a. Remove all terminal blocks for the electrical connections.
- b. If necessary, remove any covers from the rack cabinet to gain access to the rear and side.
- c. Connect up the sensor input, analog and alarm output terminal blocks to the internal rack wiring, ensuring that there is sufficient free cable to permit withdrawal of the instrument from the rack.
- d. Slide the instrument into the rack and support its weight while the four fixing screws are inserted.
- e. Ensure that the front panel of the instrument is flush and square with the front of the rack and tighten the fixing screws.
- f. Insert the terminal blocks into their respective sockets on the rear of the instrument.
- g. Connect the power supply cable and switch the **ON/OFF** switch to **ON**.
- h. Re-fit any covers to the rack as necessary.

**NOTE: Allow a minimum clearance depth of 100 mm (4") behind the instrument housing for cables and vents.**

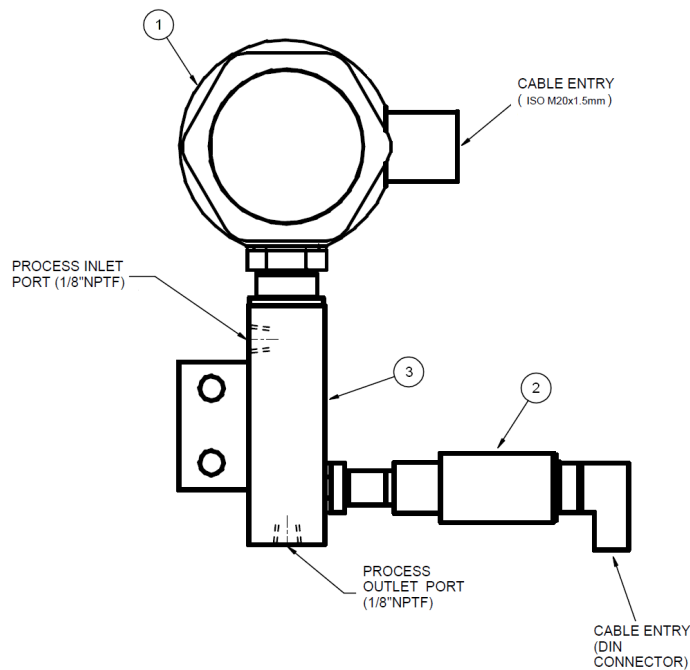


### 2.3.2 Mounting the Promet I.S. Sensor Assembly into the Sampling System



**HIGH PRESSURE!** High pressure gases are potentially hazardous. Energy stored in these gases can be released suddenly and with extreme force. High pressure systems should be assembled and operated only by people who have been trained in proper safety practices.

**NOTE:** If the analyzer has been ordered with a sampling system, the Promet I.S. sensor assembly will have been installed and tested in the factory. In that case disregard the following section and go to Section 2.3.3.



**Figure 6** Promet I.S. Sensor Assembly

The Promet I.S. sensor assembly consists of:

- 1** Dew-point transmitter – Easidew PRO I.S.
- 2** Pressure transmitter (optional)
- 3** Sensor block

To assemble, proceed as follows:

- a. Remove the protective cap on the dew-point transmitter (Easidew PRO I.S.) before installation and retain for future use. Take care to prevent any contamination of the sensor before installation (**do not touch or handle the sintered guard – located on the tip of the Easidew PRO I.S.**).

- b. The dew-point transmitter has a 5/8" UNF parallel mounting thread which should be installed directly into the sampling block with the bonded seal provided. **The bonded seal provided should be placed over the transmitter mounting thread before it is screwed into the sampling block.**
- c. Finger tighten the dew-point transmitter by gripping the spanner/wrench flats on the body – **NOT** the transmitter body cover. Completely tighten using a spanner/wrench until the bonded seal is fully compressed to a minimum torque of 30.5 Nm (22.5 lbf-ft).
- d. The pressure transmitter can be installed into one of NPTF ports on the sensor block.

To install the complete Promet I.S. sensor assembly into the sampling system, follow these steps:

- a. Select a location to mount the sensor assembly which has sufficient clearance for connecting and disconnecting the inlet/outlet tubing and cable. The surface should be strong enough to hold the analyzer.
- b. Mount the Promet I.S. sensor assembly into the sampling system via its two mounting holes.
- c. Sample gas connections are made via the gas inlet and gas outlet ports as shown in *Figure 6*. Both the gas inlet and outlet port are 1/8" NPT female ports. Michell recommends using Swagelok® 6 mm to 1/8" NPT (ordering code SS-6M0-1-2) or 1/4" to 1/8" NPT (ordering code SS-400-1-2) male connectors to connect these two ports to the 6 mm or 1/4" sampling system tubing. Follow standard Swagelok® installation instructions to make the connections.

Although the operation of the Easidew PRO I.S. dew-point transmitter is not sample flow-rate dependant, it is important to ensure that the flow velocity through the sample line to the sampling block is high enough to avoid long time lags in response to changes in moisture at the sample source. Michell recommends that a flow-rate of 1...5 NI/min (2.1...10.6 scfh) (or equivalent at pressure) be set and that the dew-point transmitter is mounted as close as practicably possible to the sample source.

### 2.3.3 Sampling System Installation



**HIGH PRESSURE!** High pressure gases are potentially hazardous. Energy stored in these gases can be released suddenly and with extreme force. High pressure systems should be assembled and operated only by people who have been trained in proper safety practices.

To install the sampling system follow the steps below:

- a. Select a location close to the measurement point. The ambient temperature should be within the range of -20...60 °C (-4...+140 °F) (preferably 0...+40 °C (+32...+104 °F) for optimum performance). Consult Michell for special heating or cooling options if the temperature is outside of this range.
- b. Fasten the sampling system to a vertical surface or instrument stand using the four M8 size mounting holes at each corner.
- c. Connect the sample inlet and outlet tubing to the fittings of the inlet/outlet ports on the sampling system. If the sampling system has been ordered from Michell, the fitting is a 6 mm or 1/4" Swagelok® bulkhead union. Follow standard Swagelok® installation instructions for the connection procedure.

**NOTE: The sampling line between the process point and the sampling system should be as short as possible to minimize the lag time.**

2.4 Wiring



**DANGER**  
Electric  
Shock Risk

These tasks are to be undertaken only by suitably qualified personnel. All the connections to the rear panel are electrical connections. Exercise due caution, particularly when connecting to external alarm circuits which could be at high potential.

2.4.1 Overall Wiring Arrangement

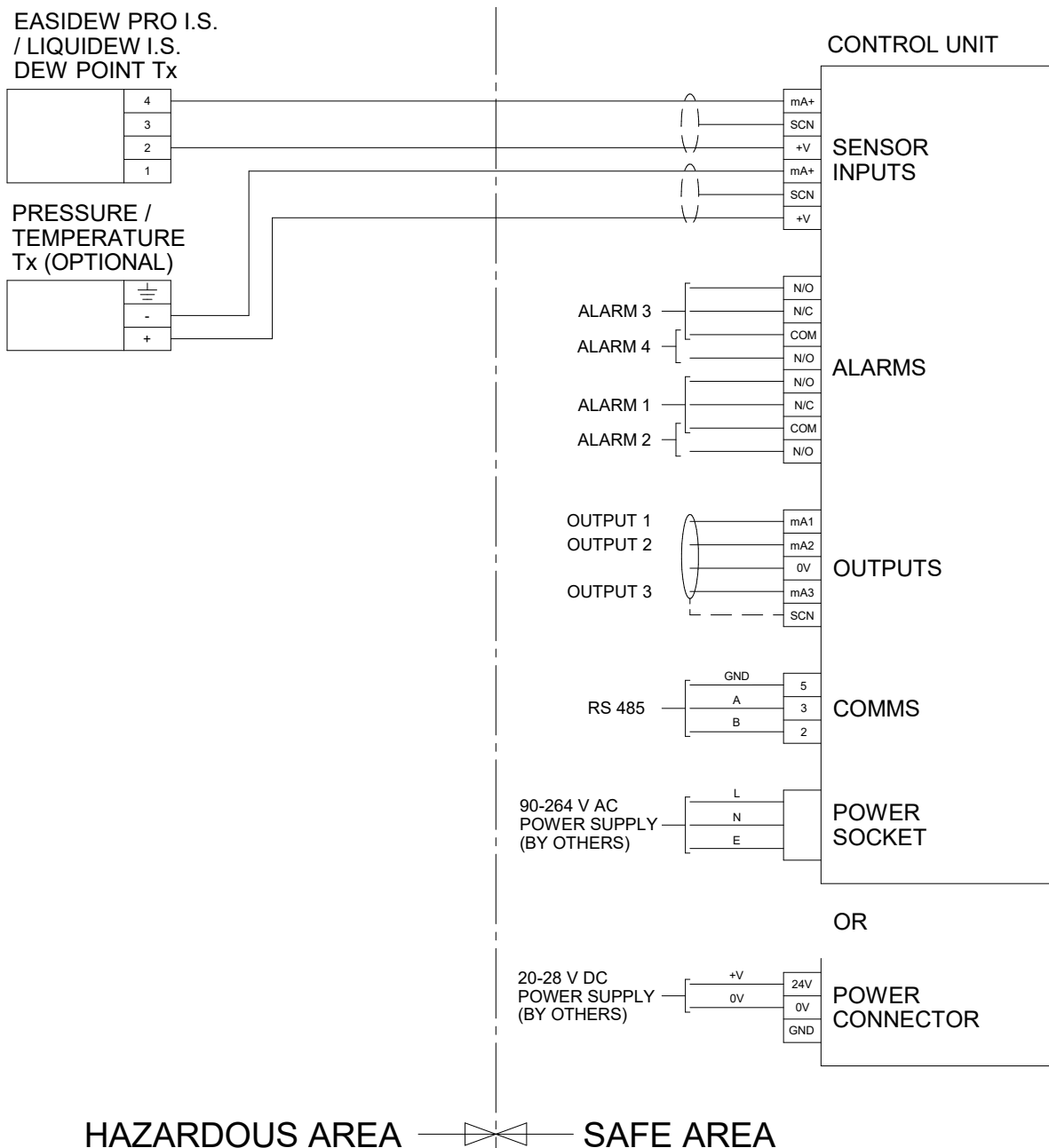


Figure 7 Overall Wiring Arrangement

2.4.2 Control Unit Wiring

The electrical connections are located at the rear panel of the control unit. There are spaces for four individual channels.



**HAZARDOUS AREA INFORMATION:**

**The only connections on the control unit which can take cables from hazardous area are the connectors labelled I.S. SENSOR INPUTS.**

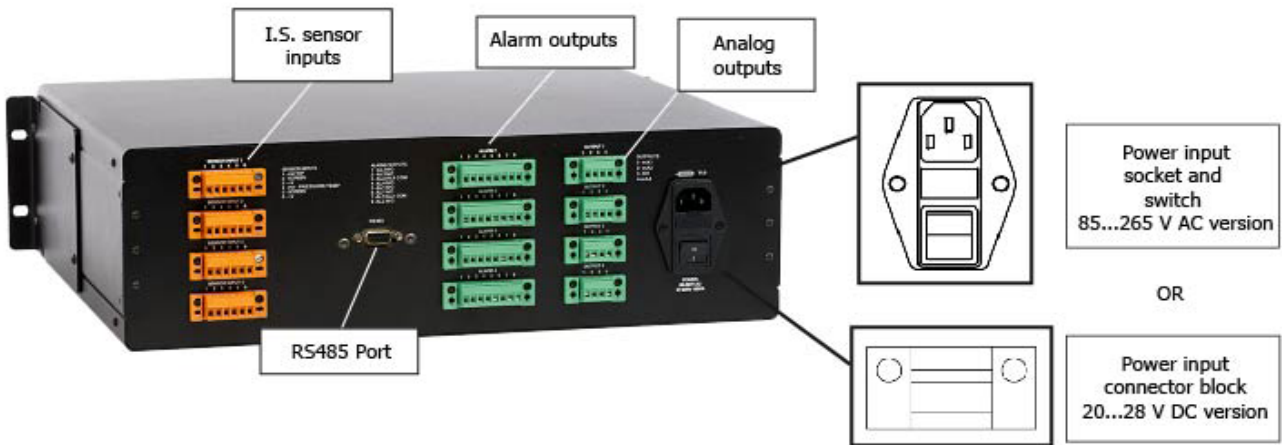
**ALL OTHER CONNECTORS MUST NOT BE CONNECTED TO CABLES FROM HAZARDOUS AREA**



**NOTE: Make sure channels are connected correctly.**

**Connections for each channel are identical.**

**The following text will only refer to one channel.**

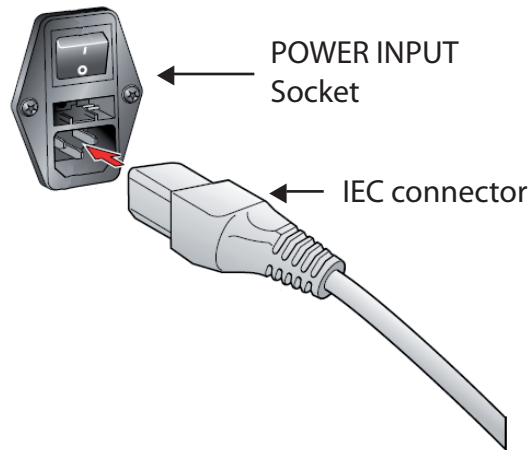


**Figure 8** Control Unit Electrical Connections

### 2.4.2.1 Power Supply Input Connection

#### 85...265 V AC

The AC power supply connection is a push fit socket labelled **POWER INPUT** as shown below.



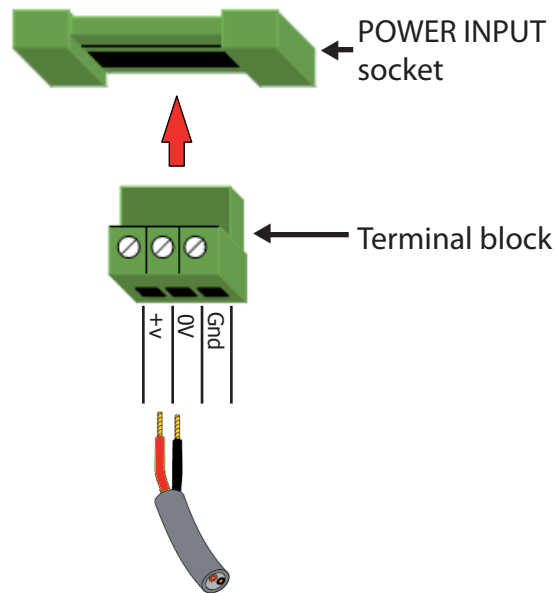
**Figure 9** *POWER INPUT Socket*

The method of connection is as follows:

- a. Turn off the AC power. Ensure that both ends of the power cable are potential free, i.e. not connected to an AC power supply.
- b. Check that the **ON/OFF** switch is switched to **OFF**.
- c. Push the IEC connector firmly into the **POWER INPUT** socket.
- d. Connect the free end of the power cable to a suitable AC power supply source (voltage range 85...265 V AC, 47/63 Hz) and switch on the AC supply. The instrument may then be switched on, as required, by pressing the **ON** switch.

## 20...28 V DC

If a DC power supply version is ordered it will come with a 3-way push fit connector block labelled **POWER INPUT** as shown below.



**Figure 10** *POWER INPUT Connector Block*

The method of connection is as follows:

- Turn off the power. Ensure that both ends of the power cable are potential free i.e., not connected to a power supply.
- Remove the terminal block from the **POWER INPUT** socket.
- Strip back the wires of the power cable, exposing approximately 6 mm (0.2") – the use of crimps/wire ferrules is recommended.
- Insert the +24 V DC lead into the +V terminal way on the terminal block and tighten the screw.
- Insert the 0 V lead into the 0 V terminal way on the terminal block and tighten the screw.
- Check that the wiring has been completed correctly.
- Push the terminal block firmly back into the **POWER INPUT** socket.

**NOTE: There is no power switch for the DC power supply version; the analyzer will be turned on automatically as soon as power is supplied.** Connect the free end of the power cable to a suitable DC power supply source (voltage range 20...28 V DC). The instrument may then be switched on, as required, by the power switch at the source.

2.4.2.2 Sensor Signal Input Connection



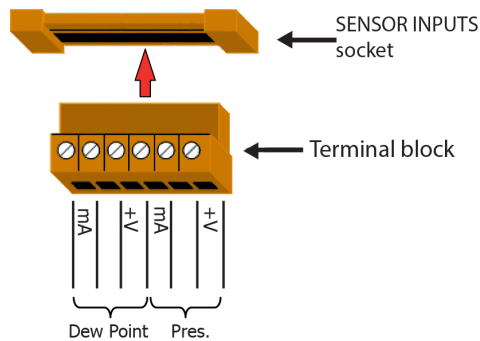
**HAZARDOUS AREA INFORMATION**

**Cables from transmitters mounted in hazardous areas can be connected directly to the SENSOR INPUTS connector block. There are built-in Galvanic I.S. barriers for all connections made to this connection block. See Appendices A and D for barrier configuration.**

**Refer to ATEX/UKCA/QPS/IECEX certificates for the dew-point and optional pressure transmitters' connection cable requirements which stipulate maximum permissible mutual capacitance and inductance to resistance ratio.**

**All wiring procedures should be in accordance with local electrical codes.**

Two input ports are provided for signals from the dew-point transmitter and the optional pressure transmitter respectively. They are connected via a single 6-way push fit connector block labelled **SENSOR INPUTS** as shown below.



**Figure 11** *SENSOR INPUTS Connector Block*

The method of connection is as follows:

- a. Remove the terminal block from the **SENSOR INPUTS** socket.
- b. Strip back the wires of the dew-point transmitter signal cable, exposing approximately 6 mm (0.2") – the use of crimps/wire ferrules is recommended.
- c. Insert the +ve (4...20 mA) wire into the **Dew Point** → +V terminal way on the terminal block and tighten the screw.
- d. Insert the -ve (4...20 mA) wire into **Dew Point** → mA terminal way on the terminal block and tighten the screw.
- e. Strip back the wires of the pressure transmitter signal cable, exposing approximately 6 mm (0.2") – the use of crimps/wire ferrules is recommended.
- f. Insert the +ve (4...20 mA) wire into the **Temp./Press.** → +V terminal way on the terminal block and tighten the screw.
- g. Insert the -ve (4...20 mA) wire into the **Temp./Press.** → mA terminal way on the terminal block and tighten the screw.
- h. Check that the wiring has been completed correctly.
- i. Push the terminal block firmly back into the **SENSOR INPUTS** socket.



### 2.4.2.3 Analog Output Connection

Three analog output ports are provided for moisture content signal and pressure signal respectively. They are connected via a single 5-way push-fit connector block labelled **OUTPUT** as explained below.

Terminal Block Pin	Output
1	mA1
2	mA2
3	0V
4	mA3
5	Screen

The method of connection is as follows:

- a. Remove the terminal block from the **OUTPUT** socket.
- b. Strip back the wires of the moisture content signal cable, exposing approximately 6 mm (0.2") – the use of crimps/wire ferrules is recommended.
- c. Insert the +ve (4...20 mA) wire into the **mA1** terminal way on the terminal block and tighten the screw.
- d. Insert the -ve (4...20 mA) wire into the **0V** terminal way on the terminal block and tighten the screw.
- e. Strip back the wires of the temperature signal cable, exposing approximately 6 mm (0.2") – the use of crimps/wire ferrules is recommended.
- f. Insert the +ve (4...20 mA) wire into the **mA2** terminal way on the terminal block and tighten the screw.
- g. Insert the -ve (4...20 mA) wire into the **0V** terminal way on the terminal block and tighten the screw.

If the third output is required:

- h. Insert the +ve (4...20 mA) wire into the **mA3** terminal way on the terminal block and tighten the screw.
- i. Insert the -ve (4...20 mA) wire into the **0V** terminal way on the terminal block and tighten the screw.
- j. Check that the wiring has been completed correctly.
- k. Push the terminal block firmly back into the **OUTPUT** socket.

2.4.2.4 Alarm Output Connection

Four alarm output ports are provided and are connected to the instrument via a single 8-way push fit connector block labelled **ALARMS** as shown below.

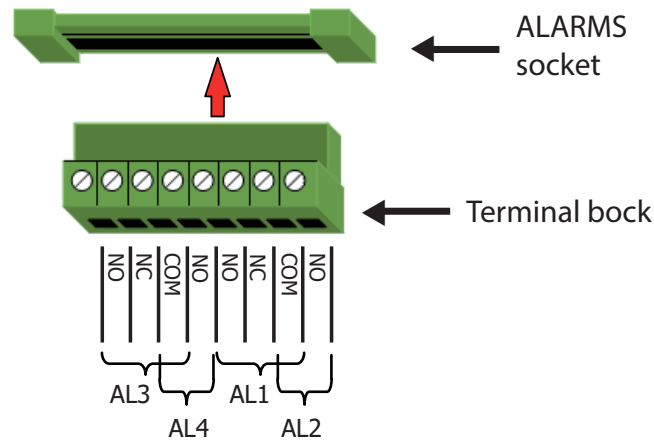
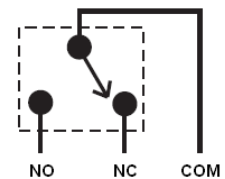


Figure 12 ALARM Connector Block

Alarm 1 (connection labelled as AL1) and Alarm 2 (connection labelled as AL2) are Form C (single pole, double throw) relays.

The method of connection is as follows:

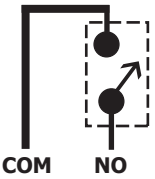
- a. Remove the terminal block from the **ALARMS** socket.
- b. Strip back the wires of the Alarm 1 cable, exposing approximately 6 mm (0.2") – the use of crimps/wire ferrules is recommended.
- c. Insert the **N/O** connection lead into the **AL1 → NO** terminal way on the terminal block and tighten the screw.
- d. Insert the **N/C** connection lead into the **AL1 → NC** terminal way on the terminal block and tighten the screw.
- e. Insert the common lead into the **AL1 → COM** terminal way on the terminal block and tighten the screw.
- f. Repeat operations b. to e. for connecting the Alarm 2 cable to the AL2 terminals.



Alarm 3 (connection labelled as AL3) and Alarm 4 (connection labelled as AL4) are Form A (single pole, single throw, normally open) relays.

The method of connection is as follows:

- a. Strip back the wires of the Alarm 3 cable, exposing approximately 6 mm (0.2”) – the use of crimps/wire ferrules is recommended.
- b. Insert the **N/O** connection lead into the **AL3 → NO** terminal way on the terminal block and tighten the screw.
- c. Insert the common lead into the **AL3 → COM** terminal way on the terminal block and tighten the screw.
- d. Repeat operations a. to c. for connecting the Alarm 4 cable to the AL4 terminals.
- e. Check that the wiring has been completed correctly.
- f. Push the terminal block firmly back into the **ALARMS** socket.



### 2.4.2.5 RS485 Port Connection

The RS485 connection is a push-fit 9-pin socket, as shown in *Figure 8*.

The method of connection is as follows:

Pin Number	Function
2	B
3	A
5	0 V

- a. Check the orientation of the RS485 connector and gently push it into the socket.
- b. Tighten the two screws on the connector.

### 2.4.3 Sensor Assembly Wiring

**NOTE:** If the analyzer has been ordered with a sampling system, the Promet I.S. sensor assembly will be wired-up in the factory to the junction box. In that case, disregard the following instructions and go to Section 3.

#### 2.4.3.1 Dew-point Transmitter Wiring



##### HAZARDOUS AREA INFORMATION

The dew-point transmitter (Easidew PRO I.S.) is certified intrinsically safe for use in hazardous areas.

Before using the Easidew PRO I.S. in any hazardous environment ensure that personnel are completely familiar with the above standards relating to the certification of this instrument and also with the further information relating to intrinsically safe apparatus to be found in standard EN 60079-14:2014 or equivalent, and up-to-date codes of practice in the country of installation.

Installation of the Easidew PRO I.S. **MUST** be as per system drawing in order to comply with the intrinsic safety regulations.

Refer to ATEX/UKCA/QPS/IECEX certificates for the dew-point and optional pressure transmitters' connection cable requirements which stipulate maximum permissible mutual capacitance and inductance to resistance ratio.

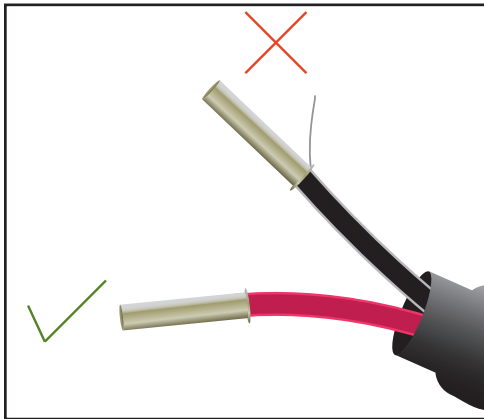
**Preparation of the Sensor Cable**



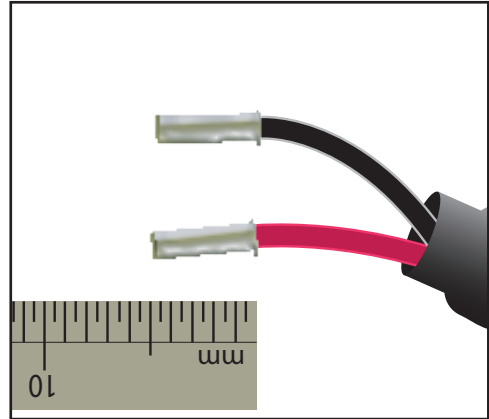
**In order to comply with hazardous area certification of the product it is essential that the crimps/wire ferrules supplied must be attached on to any cable installed into the connector.**

- a. As shown in *Figure 13* below, the crimps/wire ferrules should be applied so that there is no possibility of a conductor strand of a core becoming free.

When the crimp/wire ferrules are applied they should have a minimum of two positions of crimping. After the crimp/wire ferrules are applied they should be trimmed to a length of 5 mm (0.2") (see *Figure 14*).

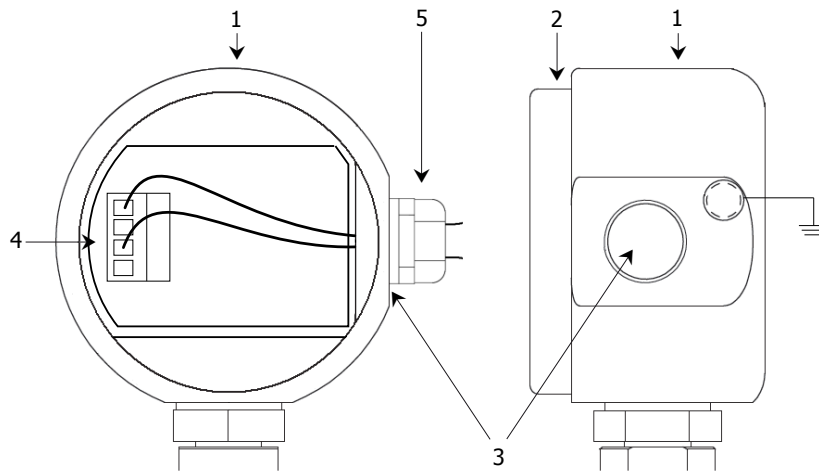


**Figure 13** *Crimped Wires*



**Figure 14** *Cut to 5 mm*

- b. Cable connection to the dew-point transmitter is made via the terminal block (4) (see *Figure 15*). Remove the terminal housing lid (2) to access.



**Figure 15** *Dew-point Transmitter Housing*

- c. Ensure that the outer diameter of the selected cable is matched to an EExe M20 cable gland (5). Unscrew the cable gland (5) and slide the cable through the cable gland (5) and into the terminal housing (1) through the cable entry (3).
- d. Remove the terminal block (4) from the PCB for easier operation. Connect the signal cable leads with the crimps/wire ferrules to the screw terminals on the terminal block (4) in accordance with the following pin-assignment drawing.

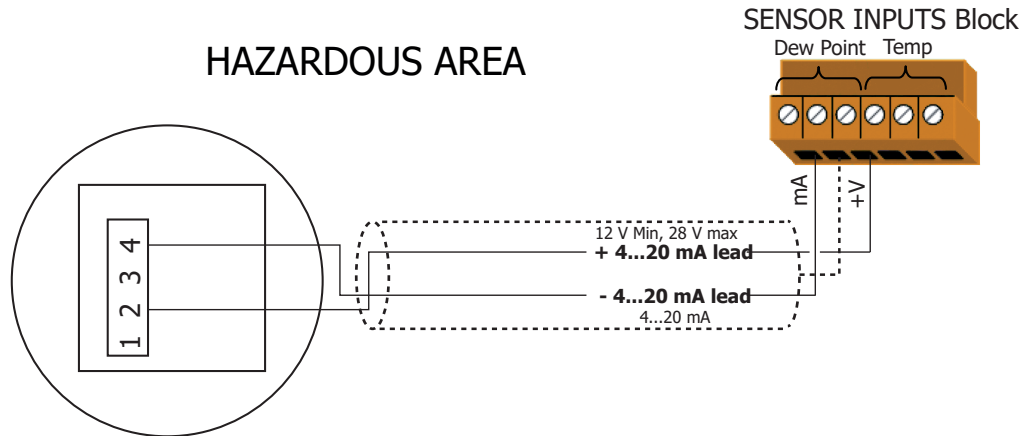


Figure 16 Pin Assignment Drawing



**Always connect the 4...20 mA return signal to a suitable load (in this case, back into the control unit) before the power is applied. Without this connection the transmitter may be damaged if allowed to operate for prolonged periods. The maximum load is 500 Ω at 24 V or 250 Ω at 12 V.**



**When the crimps/wire ferrules are installed into the connector terminal block ensure that they are inserted completely. When all wire connections are made, ensure that there is a minimum clearance distance of 2 mm (0.008") between each terminal.**

- e. Press the terminal block (4) back into its socket firmly.
- f. Tighten the cable gland (5) around the cable. Ensure that the sealing is not damaged and that the cable gland and seals are assembled correctly in order to ensure ingress protection.
- g. Install and tighten the terminal housing lid (2).

### 2.4.3.2 Optional Pressure Transmitter Wiring



#### HAZARDOUS AREA INFORMATION

The pressure transmitter is certified intrinsically safe for use in hazardous areas.

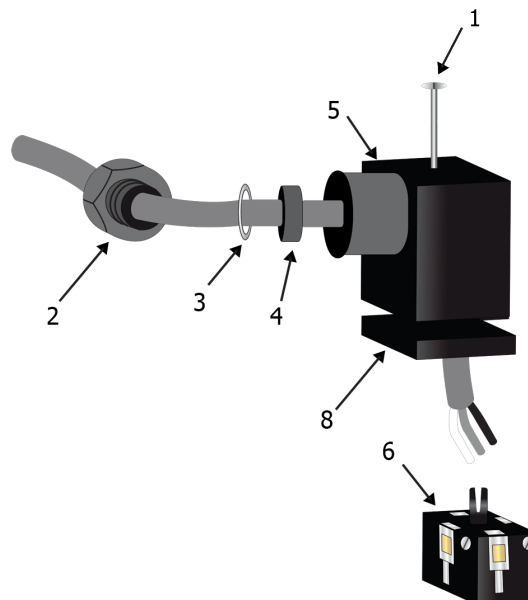
Before using the pressure transmitter in any hazardous environment ensure that personnel are competent.

If the pressure transmitter is not ordered together with the analyzer, it is the user's responsibility to make sure that the pressure transmitter is compatible with the I.S. barrier in the control unit. See Appendices A and D for barrier configuration.

Refer to ATEX/UKCA/QPS/IECEX certificates for the dew-point and optional pressure transmitters' connection cable requirements which stipulate maximum permissible mutual capacitance and inductance to resistance ratio.

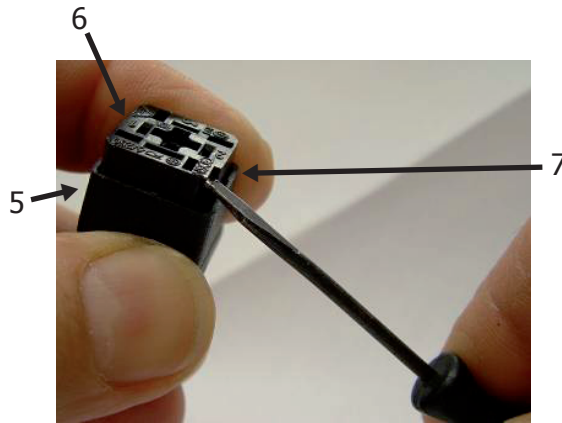
**NOTE:** A pressure transmitter will only be provided if the model with active pressure compensation is ordered. For the model without active pressure compensation, skip this section.

- a. The cable connection to the pressure transmitter is made via the removable connector. Loosen the central screw (1) to remove the connector from the transmitter.



**Figure 17** *Pressure Transmitter Connector*

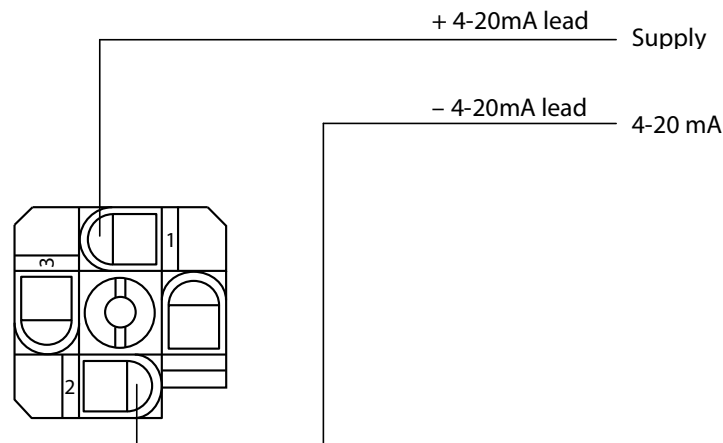
- b. When the connector is unplugged from the transmitter, remove the central screw (1) (*Figure 17*) completely.
- c. Remove the gasket (8) (*Figure 17*) from the connector.
- d. Using a small screwdriver in the mounting hole (7), lever the terminal block (6) out of the outer housing (5) (*Figure 18*).



**Figure 18** *Removal of Terminal Block*

- e. Ensure that the outer diameter of the cable selected matches the outer housing's cable gland. To ensure that full ingress protection is achieved, the sensor cable used must have a minimum diameter of 4.6 mm (0.18"). Slide the cable through the cable gland nut (2), washer (3), gland seal (4) and outer housing (5) (*Figure 17*).
- f. Apply crimps/wire ferrules to the flying leads of the cable. Connect these leads to the screw terminals on the terminal block (6) in accordance with the following pin-assignment drawing. Pin designations are marked adjacent to each pin.





**Figure 19** Pressure Transmitter Wiring Diagram



**CAUTION:** Always connect the 4...20 mA return signal to a suitable load (in this case, back into the control unit) before the power is applied. Without this connection, the transmitter may be damaged if allowed to operate for prolonged periods.

**CAUTION:** When the crimps/wire ferrules are installed into the connector terminal block ensure they are completely inserted. When all wire connections are made, ensure that there is a minimum clearance distance of 2 mm between each terminal.

- g. Press the terminal block (6) back into the outer housing (5) firmly (*Figure 18*), until a 'click' sound is heard.
- h. Tighten the cable gland (2) (*Figure 17*) around the cable. Ensure that the sealing is not damaged and that the cable gland and seals are assembled correctly in order to ensure ingress protection.
- i. Slide the terminal block (6) onto the connection pins on the transmitter. **NOTE: There is only one orientation by which the terminal block can be plugged onto the transmitter.**

## 3 OPERATION

### 3.1 Preparation



**Before applying power and beginning sample flow ensure that the system has been properly installed following the instructions in Section 2 and that all sample connections are tight and leak free. Check that the wiring has been correctly completed.**

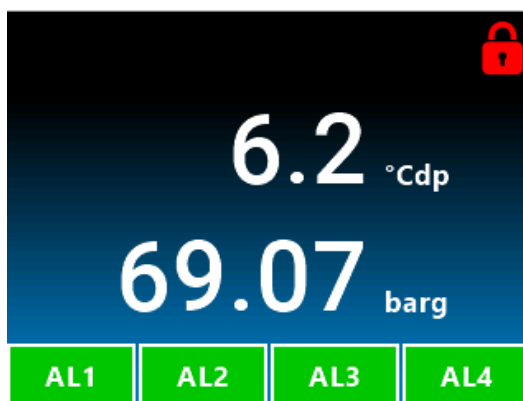
Ensure that personnel are familiar with Sections 1, 2 and 3 of this manual in which the equipment controls, indicators, elements of the display and overall menu structure are described before starting operation.

Prior to operation, the instrument must be connected to the correct electrical power supply, sensor signal input, relevant analog and alarm outputs as described in Section 2.

On delivery, the instrument will have been set-up with a standard set of default parameters defining the operation of the analyzer. These parameters can be changed as required by means of the Set-up menus.

### 3.2 Start-Up

#### 3.2.1 Main Display

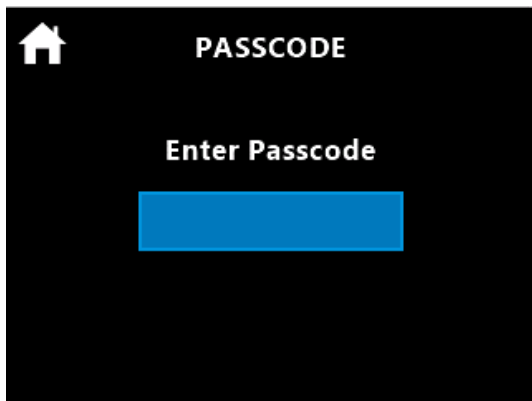


The main display shows a humidity and pressure value, the status of four alarms and a display locked/unlocked symbol.

The upper value will always represent a humidity and the lower the pressure value, which is either a live value from a pressure transmitter or a fixed value which is inputted via the pressure menu.

**To change the displayed humidity value**

Press the **LOCK** icon and enter the passcode (5618) using the keypad.



Then press the upper value to toggle between °Cdp, ppm<sub>v</sub>(I), lbmmscf, mg/m<sup>3</sup> and ppm<sub>v</sub>(N).

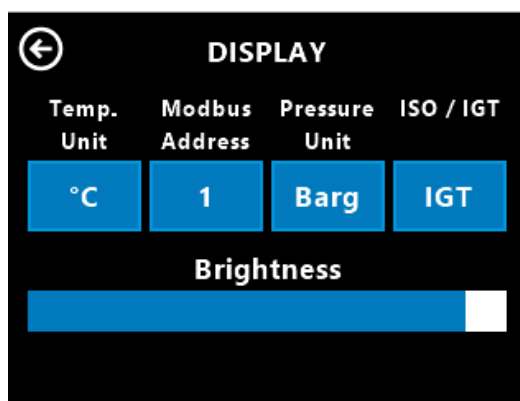
**3.2.2 Setup Menu**

To enter the Setup Menu, press the **LOCK** icon and enter the password as described above.

**Display Menu**

The display menu is used to:

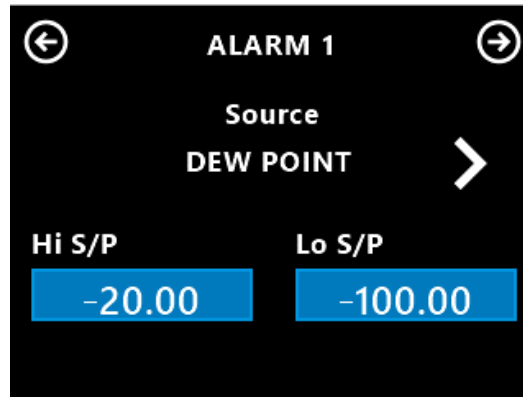
- Select the units for Dp (°C or °F). Default = °C
- Select the pressure units (barg or psig). Default = barg
- Select the data for the natural gas calculations (ISO or IGT). Default = ISO
- Set the Modbus address. Default = 1.
- Change the display brightness.



The unit selection for Dp and Pressure sets the units for the Alarm setpoints, fixed or active pressure and Input and Output ranges.

## Alarm Menu

The alarm menu sets the Source and High (Hi) and Low (Lo) set points for all 4 alarms, whereby the Source can be set, selected from Dew Point, Pressure, ppm<sub>v</sub>(I), lbmmscf, mg/m<sup>3</sup> and ppm<sub>v</sub>(N), whereby the units for the Dew Point and Pressure are set in the Display menu above.

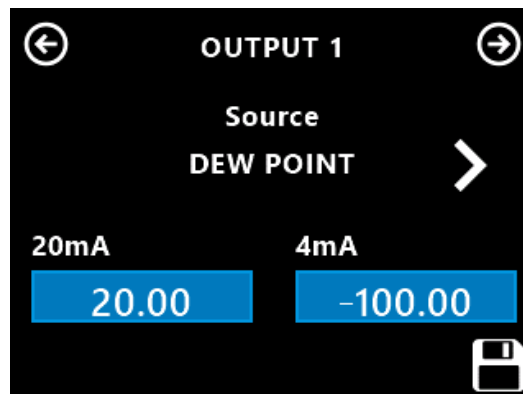


Defaults:

- AL1 = Dp (low = -100.0, high = -20.0)
- AL2 = Dp (low = -100.0, high = -40.0)
- AL3 = FAULT (low = high = 0.0)
- AL4 = FAULT (low = high = 0.0)

## Output Menu

This menu sets the range and the parameter (Source) of outputs 1 to 3. Each output can be set for either Dew Point, Pressure, ppm<sub>v</sub>(I), lbmmscf, mg/m<sup>3</sup> or ppm<sub>v</sub>(N).

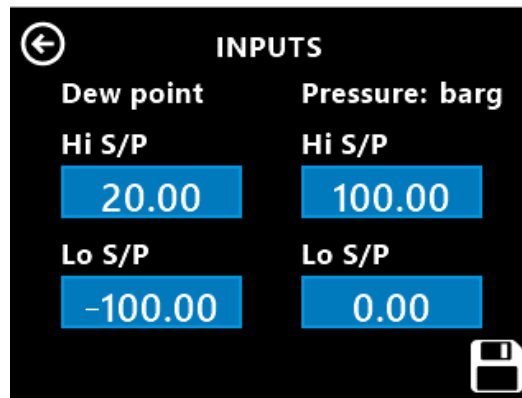


Defaults:

- OP1 = Dp (-100.0...+20.0)
- OP2 = Pressure (0.0...+100.0)
- OP3 = lbmmscf (0.0...+1000.0)

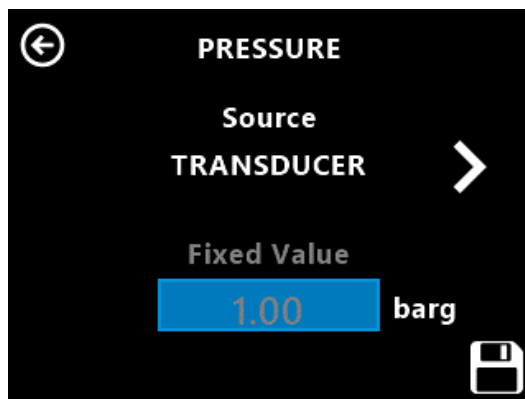
### Inputs Menu

Sets the range of the Dew Point and Pressure input channels, in the units set in the Display page. The default values are shown below:



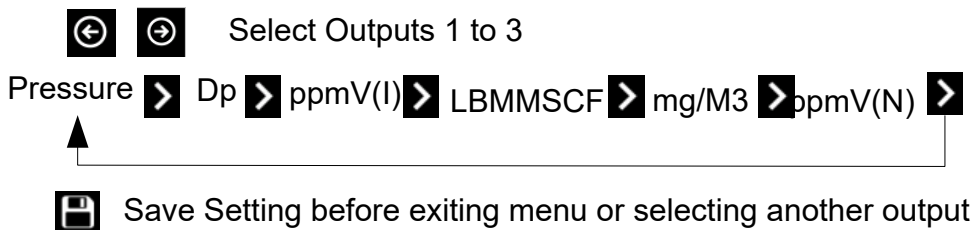
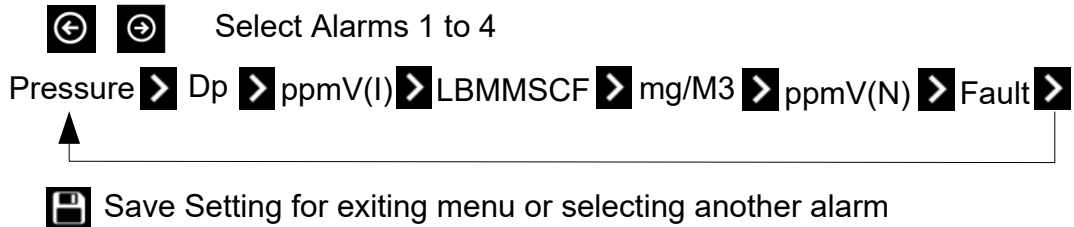
### Pressure Menu

Set the pressure source to be either from a pressure transducer or from a fixed value.



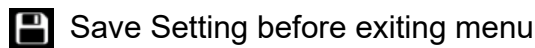
### 3.3 Menu Structure

The Promet I.S. main menu has a two-level menu structure. There are three sub-menus **DISP**, **FAULT** and **OUTPUT**. The **ALARM SETTINGS** are not in the main menu and are accessed separately. These are described in detail in the following sections. See *Figure 20*, below, for the complete menu structure.

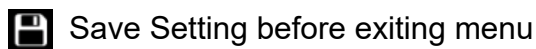


Temperature Unit (C or F) & Pressure Unit (Psig or Barg) set the units for both Inputs and Outputs.

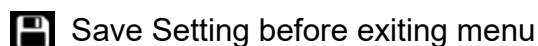
ISO & IGT selection for Natural Gas Calculations



Sets the 4-20mA range for the Dew point & Pressure Transmitters, which are in the units selected in the display menu above.



Fixed Pressure Value in the units selected in the Display menu; used for operation without a pressure transducer to calculate moisture concentration values.



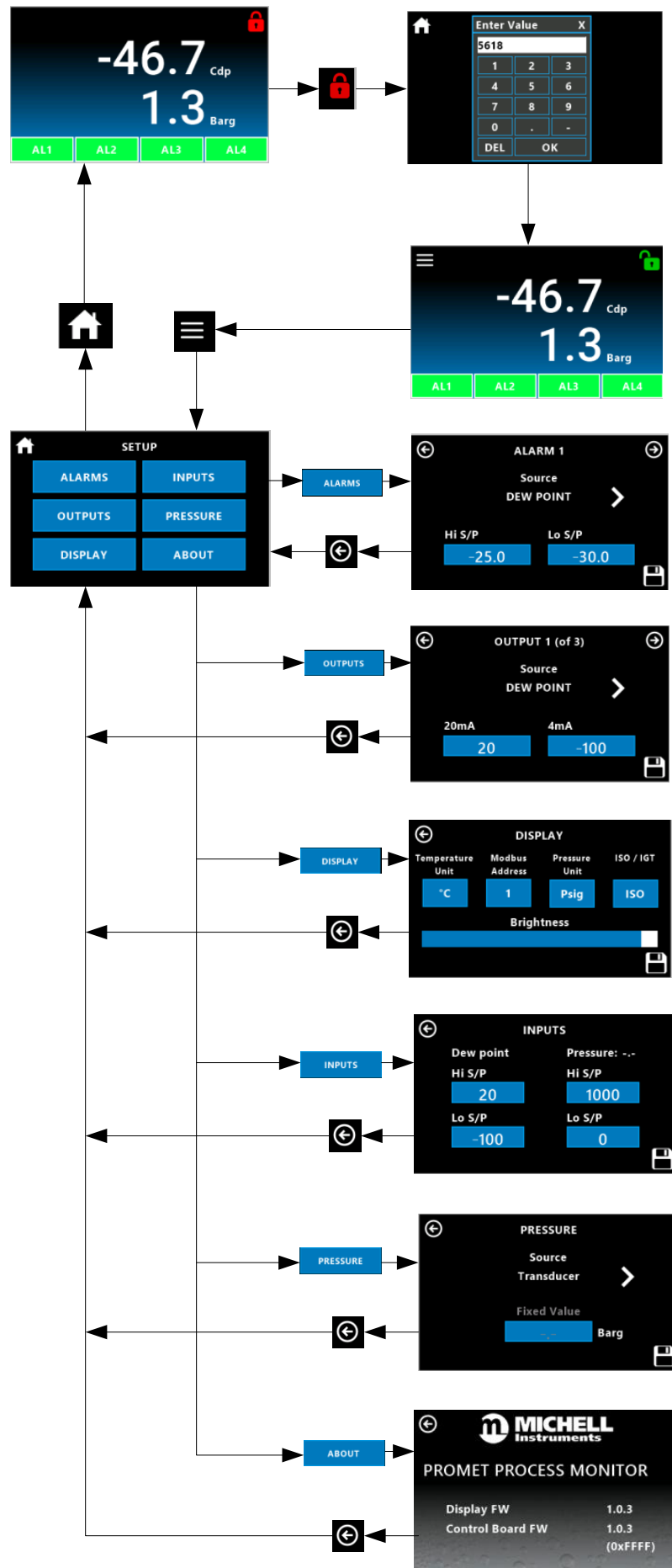


Figure 20 Menu Map

# Appendix A

## Technical Specifications

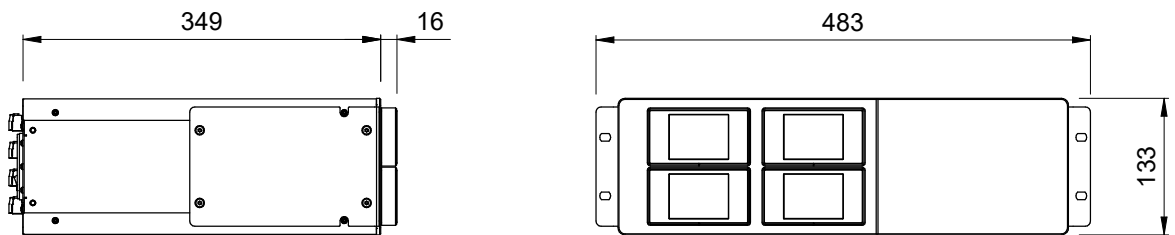


## Appendix A Technical Specifications

<b>Sensors</b>	
Sensor Technology	Michell Ceramic Metal-Oxide Moisture Sensor
Sensor Version	Easidew PRO I.S.
Measurement Range	-100...+20 °Cdp (-148...+68 °Fdp)
Calibration Range	-100...+20 °Cdp (-148...+68 °Fdp)
Calibration	Traceable to British (NPL) and American (NIST) National Humidity Standards
Accuracy	Dew point: ±1 °C between -60 and +20 °Cdp (-76 and +68 °Fdp) Moisture content: ±10% of reading Dew point: ±2 °C between -60.1 and -100 °Cdp (-76.18 and -148 °Fdp)
Resolution	0.1 °C between +20 and -100 °Cdp (+68 and -148 °Fdp)
Analysis Pressure	Up to 45 MPa (450 barg / 5801 psig)
Operating Temperature	-40...+60 °C (-40...+140 °F)
Sample Flow Rate	1...5 NI/min (2.1...10.6 scfh)
Optional Pressure Sensor	0...138 barg (other ranges available) Accuracy: ±0.25% FS
<b>Control Unit</b>	
Display	2.8" color touch screen LCD, displaying moisture content / dew point or O <sub>2</sub> and analysis pressure
Analog Output	Three 4...20 mA (max load 500 Ω) User configured for parameter, unit and range
Digital Output	RS485 Modbus RTU
Display Mode	Moisture content (ppm <sub>v</sub> ) Moisture content in natural gas (ppm <sub>v</sub> , lb/MMscf, mg/m <sup>3</sup> ) Dew point (°C or °F) Pressure (psig, barg) % or ppm <sub>v</sub> O <sub>2</sub>
Pressure Compensation	Fixed value (user programmed) or dynamic input from optional pressure sensor
Display Resolution	0.1 °Cdp, 0.1 °Fdp, 0.1...0.001 ppm <sub>v</sub> ideal gas (adjustable), 0.01 ppm <sub>v</sub> natural gas, 0.01 mg/m <sup>3</sup> , 0.01 lb/MMscf, 1 psig, 0.1 barg, 0.01 % / 0.5 ppm <sub>v</sub> O <sub>2</sub>
Alarms	Four alarm relays Control action and set-point are user-programmable Two Form C contacts rated 30 V DC, 5A Non-inductive load Two Form A contacts rated 30 V DC, 5A Non-inductive load
I.S. Barriers	Galvanic isolation type, integrated to Control Unit KFD0-CS-Ex1.50P (1 Channel) – PRO I.S. only KFD0-CS-Ex2.50P (2 Channel) – PRO I.S. and Transmitter Refer to Appendix D
Power Supply	85...265 V AC, 47/63 Hz or 20...28 V DC 30 V A maximum power consumption
Operating Environment	Indoor, safe area, 0...+50 °C (+32...+122 °F) < 90 %rh

Interconnection Cable	General instrument type, twisted pair, screened, single pair (two pairs with pressure sensor)
Enclosure	19" sub rack unit Dimensions 132 x 483 x 375 mm (5 x 19 x 14.75") (h x w x d) (100 mm (4") minimum rear clearance depth for cables and vents)
<b>Sampling Systems</b>	
Refer to relevant ES70G data sheet (97550)	
<b>Hazardous Area Certification</b>	
Certification Codes	See Appendix C

**A.1 Dimensional Drawings**



**Figure 21** Dimensional Drawings (in mm)

# Appendix B

## Serial Communications

## Appendix B Serial Communications

### To communicate with the monitor:

- Connect to the serial port using the wiring defined below.
- Set the address of the monitor using the front panel.
- Set the desired communication protocol (ASCII or Modbus RTU) via the front panel or over the serial interface.
- Determine the register number of the parameter to be read.
- Send the correct command to the monitor and decode the response.

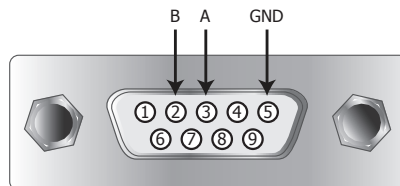
### RS485 Wiring

The Promet I.S. monitor uses a 2-wire RS485 connection.

Pin Name	Promet DB9 Pin
A	3
B	2
GND	5

Pin numbers in the manual refer to standard pins on the DB9 D-Sub connector on the rear panel of the MCU:

#### Male DB9 Pinout (Promet I.S. Monitor on MCU Panel)



It will be necessary to match up the A/B (Differential data pair) and GND (0 V) pins with the wiring of your own third party adaptor.

## Process Monitor Register Map:

Address	Function Description	Read/Write	Default Value	Register Configuration	Notes
0	Modbus Address	R/W		A1	1...32
1	Alarm Configuration	R/W		D	
2	mA output Configuration	R/W		E	
3	System Configuration	R/W		C	
4	O/p 1 low s/p hi word	R/W		FLOAT	
5	O/p 1 low s/p lo word	R/W		FLOAT	
6	O/p 1 high s/p hi word	R/W		FLOAT	
7	O/p 1 high s/p lo word	R/W		FLOAT	
8	O/p 2 low s/p hi word	R/W		FLOAT	
9	O/p 2 low s/p lo word	R/W		FLOAT	
10	O/p 2 high s/p hi word	R/W		FLOAT	
11	O/p 2 high s/p lo word	R/W		FLOAT	
12	O/p 3 low s/p hi word	R/W		FLOAT	
13	O/p 3 low s/p lo word	R/W		FLOAT	
14	O/p 3 high s/p hi word	R/W		FLOAT	
15	O/p 3 high s/p lo word	R/W		FLOAT	
16	I/p 1 min. hi word	R/W		FLOAT	
17	I/p 1 min. lo word	R/W		FLOAT	
18	I/p 1 max. hi word	R/W		FLOAT	
19	I/p 1 max. lo word	R/W		FLOAT	
20	I/p 2 min. hi word (n/a for Oxygen only)	R/W		FLOAT	
21	I/p 2 min. lo word (n/a for Oxygen only)	R/W		FLOAT	
22	I/p 2 max. hi word (n/a for Oxygen only)	R/W		FLOAT	
23	I/p 2 max. lo word (n/a for Oxygen only)	R/W		FLOAT	
24	Fixed pressure input value hi word (n/a for O <sub>2</sub> only)	R/W		FLOAT	
25	Fixed pressure input value lo word (n/a for O <sub>2</sub> only)	R/W		FLOAT	

Address	Function Description	Read/Write	Default Value	Register Configuration	Notes
26	Liquid Selection	R/W		G	
27	Liquid Mix Ratio (% of Mixed Liquid 1)	R/W		A1	
28	User Cs Table 1, Cs Value at -20 °C	R/W		A1	
29	User Cs Table 1, Cs Value at -10 °C	R/W		A1	
30	User Cs Table 1, Cs Value at 0 °C	R/W		A1	
31	User Cs Table 1, Cs Value at 10 °C	R/W		A1	
32	User Cs Table 1, Cs Value at 20 °C	R/W		A1	
33	User Cs Table 1, Cs Value at 30 °C	R/W		A1	
34	User Cs Table 1, Cs Value at 40 °C	R/W		A1	
35	User Cs Table 1, Cs Value at 50 °C	R/W		A1	
36	User Cs Table 1, Cs Value at 60 °C	R/W		A1	
37	User Cs Table 1, Cs Value at 70 °C	R/W		A1	
38	User Cs Table 2, Cs Value at -20 °C	R/W		A1	
39	User Cs Table 2, Cs Value at -10 °C	R/W		A1	
40	User Cs Table 2, Cs Value at 0 °C	R/W		A1	
41	User Cs Table 2, Cs Value at 10 °C	R/W		A1	
42	User Cs Table 2, Cs Value at 20 °C	R/W		A1	
43	User Cs Table 2, Cs Value at 30 °C	R/W		A1	
44	User Cs Table 2, Cs Value at 40 °C	R/W		A1	
45	User Cs Table 2, Cs Value at 50 °C	R/W		A1	
46	User Cs Table 2, Cs Value at 60 °C	R/W		A1	
47	User Cs Table 2, Cs Value at 70 °C	R/W		A1	
48	Dew point (O <sub>2</sub> ) Channel – ADC Val 4mA	R/W		A1	0...4095
49	Dew point (O <sub>2</sub> ) Channel – ADC Val 20mA	R/W		A1	0...4095
50	Pressure (P) /Tempr (L) Channel – ADC Val 4mA (n/a for O <sub>2</sub> only)	R/W		A1	0...4095
51	Pressure (P) /Tempr (L) Channel – ADC Val 20mA (n/a for O <sub>2</sub> only)	R/W		A1	0...4095
53	Analog Output 1 – DAC 4 mA Value	R/W		A1	0...65535

Address	Function Description	Read/Write	Default Value	Register Configuration	Notes
54	Analog Output 1 – DAC 20 mA Value	R/W		A1	0...65535
55	Analog Output 2 – DAC 4 mA Value	R/W		A1	0...65535
56	Analog Output 2 – DAC 20 mA Value	R/W		A1	0...65535
57	Analog Output 3 – DAC 4 mA Value	R/W		A1	0...65535
58	Analog Output 3 – DAC 20 mA Value	R/W		A1	0...65535
59	Display brightness	R/W		A1	0...100
60	Alarm 1 Low S/P Hi Word	R/W		FLOAT	
61	Alarm 1 Low S/P Lo Word	R/W		FLOAT	
62	Alarm 1 High S/P Hi Word	R/W		FLOAT	
63	Alarm 1 High S/P Lo Word	R/W		FLOAT	
64	Alarm 2 Low S/P Hi Word	R/W		FLOAT	
65	Alarm 2 Low S/P Lo Word	R/W		FLOAT	
66	Alarm 2 High S/P Hi Word	R/W		FLOAT	
67	Alarm 2 High S/P Lo Word	R/W		FLOAT	
68	Alarm 3 Low S/P Hi Word	R/W		FLOAT	
69	Alarm 3 Low S/P Lo Word	R/W		FLOAT	
70	Alarm 3 High S/P Hi Word	R/W		FLOAT	
71	Alarm 3 High S/P Lo Word	R/W		FLOAT	
72	Alarm 4 Low S/P Hi Word	R/W		FLOAT	
73	Alarm 4 Low S/P Lo Word	R/W		FLOAT	
74	Alarm 4 High S/P Hi Word	R/W		FLOAT	
75	Alarm 4 High S/P Lo Word	R/W		FLOAT	
76	Virgin PCB	R	12345	A1	
77	Command register	W		H	
78	Number of alarms (not used)	R/W		A1	
80	Dew point in set unit (or O <sub>2</sub> for O <sub>2</sub> only)	R		B2	-3276.8 ...3276.7
81	Pressure (P) / Temperature (L) in set unit (n/a for O <sub>2</sub> only)	R		B2	-3276.8 ...3276.7
82	Moisture – ppm <sub>w</sub> – Hi Word	R		IEEE754	

Address	Function Description	Read/Write	Default Value	Register Configuration	Notes
83	Moisture – ppm <sub>w</sub> – Lo Word	R		IEEE754	
84	Moisture – ppm <sub>v</sub> (Ideal) – Hi Word	R		IEEE754	
85	Moisture – ppm <sub>v</sub> (Ideal) – Lo Word	R		IEEE754	
86	Moisture – ppm <sub>v</sub> (Nat Gas) – Hi Word	R		IEEE754	
87	Moisture – ppm <sub>v</sub> (Nat Gas) – Lo Word	R		IEEE754	
88	Moisture – mg/m <sup>3</sup> (Nat Gas) – Hi Word	R		IEEE754	
89	Moisture – mg/m <sup>3</sup> (Nat Gas) – Lo Word	R		IEEE754	
90	Moisture – lb/mmscf (Nat Gas) – Hi Word	R		IEEE754	
91	Moisture – lb/mmscf (Nat Gas) – Lo Word	R		IEEE754	
92	Status Register	R		F	
93	Firmware version (Main Board)	R		A3	
94	Input CH1 (Dp or O <sub>2</sub> ) Live ADC Count	R		A1	
95	Input CH2 (Pressr/Temp) Live ADC Count (n/a for O <sub>2</sub> only)	R		A1	
96	Product I.D.	R	Promet 52822 Liquidew 52823 Oxygen 52830	A1	
97	Password (volatile)	R/W	4792	A1	
101	Dew point (or O <sub>2</sub> ) in set unit as float – Hi Word	R		IEEE754	
102	Dew point (or O <sub>2</sub> ) in set unit as float – Lo Word	R		IEEE754	
103	Pressure / Temp. in set unit as float – Hi Word (n/a for O <sub>2</sub> only)	R		IEEE754	
104	Pressure / Temp. in set unit as float – Lo Word (n/a for O <sub>2</sub> only)	R		IEEE754	



**Register Configuration A**

15	14	13	12	11	10	9	8	7	6	5	4	3	2	1	0

A1: Unsigned Short. Range = 0...65535  
 A2: Unsigned Short /10. Range = 0...6553.5  
 A3: Unsigned Short /100. Range = 0...655.35

Conversion: float\*x = unsigned integer  
 Unsigned integer/x = float

Or cast:

float value to read= ((float) (value))/x;  
 unsigned short value to write= (unsigned short) (value\*x)

**Register Configuration B**

15	14	13	12	11	10	9	8	7	6	5	4	3	2	1	0

B1: Signed Short. Range -32768...+32767  
 B2: Signed Short /10. Range -3276.8...+3276.7  
 B3: Signed Short /100. Range -327.68...+327.67

Most languages will cast from one type to another

Values to write into register manually:

if value is a negative number: (value\*x) +65536  
 if value is 0 or a positive number: value\*x

e.g. for type B3

$(-5.39*100) + 65536 = 64997$   
 $(2.01*100) = 201$

Or Cast:

(unsigned short) (value\*x)

Reading values from register manually:

If value in register is greater than 32767: (value-65536)/x  
 If value in register is less than or equal to 32767: value/x

e.g. for type B3

$(64997-65536)/100 = -5.39$   
 $201/100 = 2.01$

Or Cast:

((float) ((signed short)value))/x;

**Register Configuration C – System Configuration**

15	14	13	12	11	10	9	8	7	6	5	4	3	2	1	0
		PP	MOD	CA	PR	IT	IT		TU	PU	PU	N/A	MU	MU	MU

<u>Pressure Units (PU)</u> 00 = Bar.G (def) 01 = Psi.G 10 = Mpag 11 = Spare	<u>Temperature Unit (TU)</u> 0 = C (def) 1 = F
<u>Main Unit</u> 0 = Dp (O <sub>2</sub> %) 1 = ppm <sub>v</sub> (I) (O <sub>2</sub> ppm) 2 = lbmmscf 3 = mg/m <sup>3</sup> 4 = ppm <sub>v</sub> (N)	<u>Instrument Type (IT) – not used</u> 00 = Promet IS 01 = Liquidew IS 10 = Pura 11 = O <sub>2</sub>
<u>Pressure Source (PR)</u> 0 = Sensor 1 = Fixed User	<u>ISO or IGT calculations (CA)</u> 0=IGT 1=ISO
<u>Model (MOD)</u> 0 = Promet 1 = Easidew Advanced	<u>Pressure or ppm<sub>v</sub> (I) secondary parameter (PP) – Easidew Advanced only</u> 0 = Pressure 1 = ppm <sub>v</sub> (ideal)

**Register Configuration D – Alarm Configuration**

15	14	13	12	11	10	9	8	7	6	5	4	3	2	1	0
A4	A4	A4	A4	A3	A3	A3	A3	A2	A2	A2	A2	A1	A1	A1	A1

<u>Alarm1 Parameter (A1)</u> 0000 = Dew point (O2) 0001 = Pressure/Temperature 0010 = ppm <sub>w</sub> 0011 = ppm <sub>v</sub> (Ideal) 0100 = ppm <sub>v</sub> (Nat Gas) 0101 = mgm <sup>3</sup> 0110 = lbmmscf 1000 = Fault	<u>Alarm2 Parameter (A2)</u> 0000 = Dew point (O2) 0001 = Pressure/Temperature 0010 = ppm <sub>w</sub> 0011 = ppm <sub>v</sub> (Ideal) 0100 = ppm <sub>v</sub> (Nat Gas) 0101 = mgm <sup>3</sup> 0110 = lbmmscf 1000 = Fault
<u>Alarm3 Parameter (A3)</u> 0000 = Dew point (O2) 0001 = Pressure/Temperature 0010 = ppm <sub>w</sub> 0011 = ppm <sub>v</sub> (Ideal) 0100 = ppm <sub>v</sub> (Nat Gas) 0101 = mgm <sup>3</sup> 0110 = lbmmscf 1000 = Fault	<u>Alarm4 Parameter (A4)</u> 0000 = Dew point (O2) 0001 = Pressure/Temperature 0010 = ppm <sub>w</sub> 0011 = ppm <sub>v</sub> (Ideal) 0100 = ppm <sub>v</sub> (Nat Gas) 0101 = mgm <sup>3</sup> 0110 = lbmmscf 1000 = Fault

**Register Configuration E – mA Output Config**

15	14	13	12	11	10	9	8	7	6	5	4	3	2	1	0
				O3	O3	O3	O3	O2	O2	O2	O2	O1	O1	O1	O1

<u>Output1 Parameter (O1)</u> 0000 = Dew point (O2) 0001 = Pressure/ Temperature 0010 = ppm <sub>w</sub> 0011 = ppm <sub>v</sub> (Ideal) 0100 = ppm <sub>v</sub> (Nat Gas) 0101 = mgm <sup>3</sup> 0110 = lbmmscf	<u>Output2 Parameter (O2)</u> 0000 = Dew point (O2) 0001 = Pressure/ Temperature 0010 = ppm <sub>w</sub> 0011 = ppm <sub>v</sub> (Ideal) 0100 = ppm <sub>v</sub> (Nat Gas) 0101 = mgm <sup>3</sup> 0110 = lbmmscf	<u>Output3 Parameter (O3)</u> 0000 = Dew point (O2) 0001 = Pressure/ Temperature 0010 = ppm <sub>w</sub> 0011 = ppm <sub>v</sub> (Ideal) 0100 = ppm <sub>v</sub> (Nat Gas) 0101 = mgm <sup>3</sup> 0110 = lbmmscf
---	---	---

**Register Configuration F – Status Register**

15	14	13	12	11	10	9	8	7	6	5	4	3	2	1	0
A4	A4	A3	A3	A2	A2	A1	A1							PS	DS

<u>Relay Alarm Status flags (A1, A2, A3, A4)</u> Example: A1 = 00=OK (relay de-energized) A1 = 01=High (or Fault) (relay energized) A1 = 10=Low (relay energized)	<u>Dew point Sensor Status (DS)</u> 0=OK 1=Fault (or not available)
<u>Pressure/Temperature Sensor Status (PS)</u> 0=OK 1=Fault (or not available)	

## Register Configuration G – Liquid Selection

15	14	13	12	11	10	9	8	7	6	5	4	3	2	1	0
	M2	M2	M2	M2	M2	M1	M1	M1	M1	M1	LQ	LQ	LQ	LQ	LQ

<u>Liquid Selection (LQ)</u>	<u>Mixed Liquid 1 (M1)</u>	<u>Mixed Liquid 1 (M2)</u>
0 = n-Butane	0 = n-Butane	0 = n-Butane
1 = n-Propane	1 = n-Propane	1 = n-Propane
2 = n-Hexane	2 = n-Hexane	2 = n-Hexane
3 = Cumene	3 = Cumene	3 = Cumene
4 = Benzene	4 = Benzene	4 = Benzene
5 = Toluene	5 = Toluene	5 = Toluene
6 = 1-butane	6 = 1-butane	6 = 1-butane
7 = Cyclohexane	7 = Cyclohexane	7 = Cyclohexane
8 = Oct-3-ene	8 = Oct-3-ene	8 = Oct-3-ene
9 = Ethylbenzene	9 = Ethylbenzene	9 = Ethylbenzene
10 = Dimethylbenzene	10 = Dimethylbenzene	10 = Dimethylbenzene
11 = Ethane	11 = Ethane	11 = Ethane
12 = Methylcyclohexane	12 = Methylcyclohexane	12 = Methylcyclohexane
13 = Butylbenzene	13 = Butylbenzene	13 = Butylbenzene
14 = Prop-1-ene	14 = Prop-1-ene	14 = Prop-1-ene
15 = But-1-ene	15 = But-1-ene	15 = But-1-ene
16 = Methane	16 = Methane	16 = Methane
17 = 2-Methylbutane	17 = 2-Methylbutane	17 = 2-Methylbutane
18 = USER1	18 = USER1	18 = USER1
19 = USER2	19 = USER2	19 = USER2
20 = MIXING		

**Register Configuration H – Instrument Setup and Command Register (Reg 30)**

2 = Set Dew point Channel 4 mA ADC Value  
 3 = Set Dew point Channel 20 mA ADC Value  
 4 = Set Pressure/Temperature Channel 4 mA ADC Value  
 5 = Set Pressure/Temperature Channel 20 mA ADC Value

10 = Force Analog Output 1...4 mA  
 11 = Force Analog Output 1...20 mA  
 12 = Force Analog Output 2...4 mA  
 13 = Force Analog Output 2...20 mA  
 14 = Force Analog Output 1...12 mA  
 15 = Force Analog Output 2...12 mA  
 16 = Force Analog Output 3...4 mA  
 17 = Force Analog Output 3...20 mA  
 18 = Force Analog Output 3...12 mA

19 = All Alarm Relays de-energized  
 20 = Energize Alarm Relay1  
 21 = Energize Alarm Relay2  
 22 = Energize Alarm Relay3  
 23 = Energize Alarm Relay4

25 = Send Test String to Display Comms Channel

30 = Set control board to default register map values

31 = Enable Setup Mode (Alarms and Analog output updates disabled)  
 32 = Disable Setup Mode (Alarms and Analog output updates enabled)

**Defaults (auto-loaded when PCB is brand new or forced via Modbus)**

Modbus ID	1
System config.	Main unit = °CDp Pressure unit = barg Pressure source = external Fixed pressure = 1.00
Alarm config.	AL1 = Dp (low = -100.0, high = -20.0) AL2 = Dp (low = -100.0, high = -40.0) AL3 = FAULT (low = high = 0.0) AL4 = FAULT (low = high = 0.0)
Input scales	Dp = -100...+20.0 Pressure = 0.0...+69.0
Output config.	OP1 = Dp (-100.0...+20.0) OP2 = Pressure (0.0...+69.0) OP3 = lbmmscf (0.0...+1000.0)

# Appendix C

## Hazardous Area Certification

## Appendix C Hazardous Area Certification

### The Promet I.S. Process Moisture Analyzer utilizes the Easidew PRO I.S. dew-point transmitter

The Easidew PRO I.S is certified compliant to the ATEX Directive (2014/34/EU), the IECEx scheme and SI 2016 No. 1107 UKCA product marking scheme for use within Zone 0, 1 and 2 Hazardous Areas and has been assessed as being so by CML Bv Netherlands (Notified Body 2776) and EUROFINS CML UK (Approved Body 2503).

The Easidew PRO I.S is certified compliant to the applicable North American Standards (USA and Canada) for use within Class I, Division 1 and Class I, Zone 0 Hazardous Locations and has been assessed as being so by QPS.

#### C.1 ATEX/UKCA

Certificate: Baseefa06ATEX0330X / BAS21UKEX0014X

Certification: II 1 G Ex ia IIC T4 Ga  
Tamb -20°C to +70°C

Standards: EN 60079-0:2012+A11:2013, EN 60079-11:2012

#### C.2 IECEx

Certificate: IECEx BAS 06.0090X

Certification: Ex ia IIC T4 Ga  
Tamb -20°C to +70°C

Standards: IEC 60079-0:2011, IEC 60079-11:2011

#### C.3 North American (cQPSus)

Certificate: LR1507-10

Certification: Class I, Division 1, Groups A, B, C & D T4  
Tamb -20°C to +70°C  
Class I, Zone 0  
AEx ia IIC T4 Ga / Ex ia IIC T4 Ga  
Tamb +70°C

Standards: UL 60079-0-7th ed. / CSA C22.2 No. 60079-0:19  
UL 60079-11-6th ed. / CSA C22.2 No. 60079-11:14  
UL 61010-1-3rd ed. / C22.2 No. 61010-1:12  
FM 3600-2018, FM 3610-2018

These certificates can be viewed or downloaded from our website at:  
[www.ProcessSensing.com](http://www.ProcessSensing.com)

#### C.4 Terminal Parameters

$U_i$	= 28 V
$I_i$	= 93 mA
$P_i$	= 820 mW
$C_i$	= 37 nF
$L_i$	= 0

#### C.5 Special Conditions

1. The wiring connections to the free socket must be made via crimped connectors in such a way that all the strands of the wire used are held securely by the crimp.
2. The plastic plug and socket create a potential for electrostatic discharge so must not be rubbed with a dry cloth or cleaned with solvents.
3. The Easidew PRO I.S Dew-Point Transmitter does not withstand the 500 V AC insulation test to frame. This must be taken into account when installing the equipment.

#### C.6 Maintenance and Installation

The Easidew PRO I.S. must only be installed by suitably qualified personnel and in accordance with the instructions provided and the terms of the applicable product certificates.

Maintenance and servicing of the product must only be carried out by suitably trained personnel or returned to an approved Michell Instruments Service Center.



# Appendix D

## System Drawings

Appendix D System Drawings

D.1 Baseefa Approved System Drawing

TABLE A

Type	Certificate Number	Interface	Connection to Easidew I.S.
Isolated Repeater	BAS98ATEX7343	KFD0-CS-Ex1.50P	Pin 1 (+) Pin 2 (-)
Dual Isolated Repeater	BAS98ATEX7343	KFD0-CS-Ex2.50P	Channel 1 - Pin 1 (+) Channel 1 - Pin 2 (-) Channel 2 - Pin 4 (+) Channel 2 - Pin 5 (-)
Transmitter Supply Isolator	BAS00ATEX7164	KFD2-CR-Ex1.20200	Pin 1 (+) Pin 3 (-)
Transmitter Supply Isolator	BAS00ATEX7164	KFD2-CR-Ex1.30200	Pin 1 (+) Pin 3 (-)
Smart Transmitter Power Supply	BAS99ATEX7060	KFD2-STC4-Ex1.H	Pin 1 (+) Pin 3 (-)
Repeater Power Supply	BAS01ATEX7155	MTL5041	Pin 2 (+) Pin 1 (-)
Dual Loop Isolator	BAS98ATEX2227	MTL5040	Pin 2 (+) Pin 1 (-) Pin 5 (+) Pin 4 (-)
Repeater Power Supply	BaseefaATEX0213	MTL5541	Pin 2 (+) Pin 1 (-)

THE CAPACITANCE AND EITHER THE INDUCTANCE OR THE INDUCTANCE TO RESISTANCE RATIO (L/R) OF THE CABLE MUST NOT EXCEED THE FOLLOWING VALUES:

GROUP	CAPACITANCE (µF)	INDUCTANCE (mH) OR	L/R RATIO (µH/ohm)
IIC	SEE NOTE 1 * 40 nF	4.2mH	54 µH/Ω
IIB	613 nF	12.6mH	217 µH/Ω
IIA	2.11 µF	33mH	435 µH/Ω

THE ISOLATION OF THE SIGNAL WIRES WITH THE EASIDEW DISCONNECTED, MUST BE ABLE TO WITHSTAND A 500V AC INSULATION TEST.

AT INSTALLATION OF SYSTEM PERFORM A RISK ASSESSMENT IN ACCORDANCE WITH EN60079-25:2004 cl.10 AND INSTALL LIGHTNING PROTECTION AS NECESSARY.

THE SYSTEM MUST BE MARKED WITH A DURABLE LABEL. THE LABEL SHOULD APPEAR ON OR ADJACENT TO THE PRINCIPAL ITEM OF ELECTRICAL APPARATUS IN THE SYSTEM OR AT THE INTERFACE BETWEEN THE INTRINSICALLY SAFE AND NON-INTRINSICALLY SAFE CIRCUITS. THIS MARKING SHALL INCLUDE THE FOLLOWING INFORMATION:

Baseefa 07Y0027 AND THE WORD SYST OR SYSTEM.

**NOTE 1.** 46nF MAXIMUM CABLE CAPACITANCE IS ACCEPTABLE IN IIC INSTALLATIONS

FOR THE INTRINSIC SAFETY ISOLATORS SHOWN IN THE LIST BELOW.

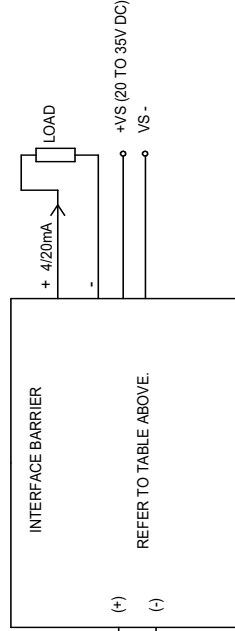
FOR ISOLATORS NOT LISTED BELOW, BUT APPEARING IN TABLE A ONLY 40nF

MAXIMUM CABLE CAPACITANCE IS ACCEPTABLE.

- KFD0-CS-Ex1.50P
- KFD0-CS-Ex2.50P
- KFD0-CR-Ex1.20200
- KFD0-CR-Ex1.30200
- MTL5041
- MTL5040
- MTL5541

**GALVANIC ISOLATION INTERFACE**

HAZARDOUS AREA ← → SAFE AREA



TRANSMITTER VERSION TERMINAL NUMBER	
EASIDEW I.S.	EASIDEW PRO I.S.
3	2 (+)
1	(RETURN)

**SYSTEM LABEL**

**MICHELL Instruments**  
 EASIDEW I.S. DEWPOINT TRANSMITTER  
 SYSTEM CERTIFICATE No's: Baseefa07Y0027  
 Ex ia IIC T4 (-20C TO +70C)

THIS DOCUMENT IS THE PROPERTY OF MICHELL INSTRUMENTS LTD. AND MUST NOT BE COPIED NOR DISCLOSED TO A THIRD PARTY WITHOUT THE CONSENT OF MICHELL INSTRUMENTS.



3rd ANGLE PROJECTION	TOLERANCES: UNLESS OTHERWISE STATED 0 DEC. PLACE: ±0.5 HOLE Ø: 0.0 1 DEC. PLACE: ±0.2 ANGLES: 30.0° 2 DEC. PLACE: ±0.1	DRAWING UNITS	SCALE	05 13385	16/12/13	IMA
		mm	NTS	04 11165	10/08/11	IMA
				PRO Variation	16/02/09	IMA
				02 08057	27/05/08	IMA
				01 CERT ISS	28/01/07	MSB
				ISSUE MOD. No.	DATE	SIGN
DRAWING NUMBER						
<b>Ex90352</b>						
TITLE						
<b>EASIDEW I.S. and EASIDEW PRO I.S. DEWPOINT TRANSMITTER SYSTEM DRAWING</b>						
USED ON						
MICHELL INSTRUMENTS LTD. CAMBRIDGE ©						
SHEET 1 OF 1						
A3						

D.2 QPS Approved System Drawing

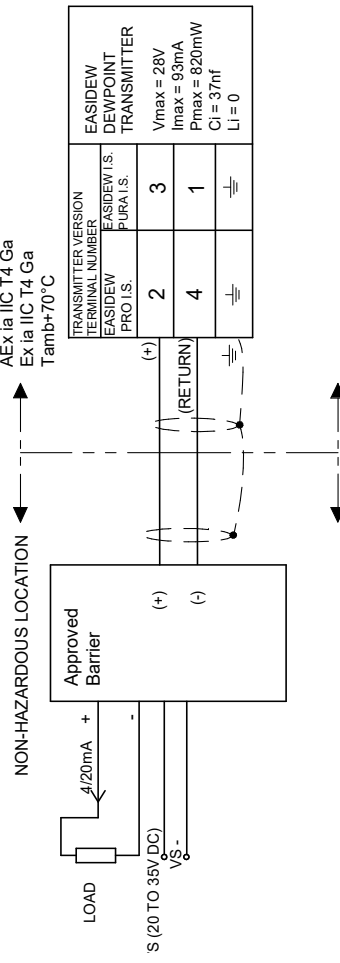
THE CAPACITANCE AND EITHER THE INDUCTANCE OR THE INDUCTANCE TO RESISTANCE RATIO (L/R) OF THE CABLE MUST NOT EXCEED THE FOLLOWING VALUES:

GROUP	CAPACITANCE (µF)	INDUCTANCE (mH) OR L/R RATIO (µH/ohm)
AB	46 nF	54 µH/Ω
C	613 nF	217 µH/Ω
D	2.1 µF	435 µH/Ω

THE ISOLATION OF THE SIGNAL WIRES WITH THE EASIDEW DISCONNECTED, MUST BE ABLE TO WITHSTAND A 500V AC INSULATION TEST. THE INSTALLATION MUST COMPLY WITH THE INSTALLATION PRACTICES OF THE COUNTRY OF USE. i.e. ANS/ISA RP12.8 (INSTALLATION OF INTRINSICALLY SAFE SYSTEMS FOR HAZARDOUS [CLASSIFIED] LOCATIONS) AND THE NATIONAL ELECTRICAL CODE ANS/NFPA 70.

THE CAPACITANCE AND THE INDUCTANCE OF THE HAZARDOUS AREA CABLES MUST NOT EXCEED THE VALUES GIVEN IN TABLE 1

HAZARDOUS LOCATION  
CLASS I, DIVISION 1,  
Gps A, B, C, & D  
CLASS I, ZONE 0  
AEx ia IIC T4 Ga  
Ex ia IIC T4 Ga  
Tamb=70 °C



TRANSMITTER VERSION	EASIDEW I.S.	EASIDEW DEWPOINT TRANSMITTER
2	3	Vmax = 28V Imax = 93mA Pmax = 820mW Ci = 37nF Li = 0
4	1	

- Intrinsically safe( entity). Class 1, Div1, Group A, B, C, D  
Hazardous Location Installations
- Control room equipment may not use or generate over 250Vrms.
  - Wire all circuits for power supply per CEC Part 1.
  - Use only entity approved safety barrier or other associated equipment that satisfy the following conditions:

$$V_{CG} \leq V_{max} \leq I_{max} \cdot C_{CABLE}, C_{CABLE} \geq C_i + C_{CABLE}, L \geq L_i + L_{CABLE}$$

Transmitter entity parameters are as follows:

$$V_{max} < 2.8V_{dc}$$

$$I_{max} < 93mA$$

$$C_i = 37nF$$

$$L_i = 0\mu H$$

- WARNING: SUBSTITUTION OF COMPONENTS MAY IMPARE INTRINSIC SAFETY.
- Ex ia is defined as Intrinsically Safe.

Type	Certificate Number	Interface	Connection to Easidew I.S.
Isolated Repeater	BAS99ATEX7343 UL Canada E106378CUL	KFD0-CS-EX1.50P	Pin 1 (+) Pin 2 (-)
Dual Isolated Repeater	BAS99ATEX7343 UL Canada E106378CUL	KFD0-CS-EX2.50P	Channel 1 - Pin 1 (+) Channel 1 - Pin 2 (-) Channel 2 - Pin 4 (+) Channel 2 - Pin 5 (-)
Transmitter Supply Isolator	BAS00ATEX7164 UL Canada E106378CUL	KFD2-QR-EX1.20200	Pin 1 (+) Pin 3 (-)
Transmitter Supply Isolator	BAS00ATEX7164 UL Canada E106378CUL	KFD2-QR-EX1.30200	Pin 1 (+) Pin 3 (-)
Smart Transmitter Power Supply	BAS99ATEX7060 UL Canada E106378CUL	KFD2-STC4-EX1.H	Pin 1 (+) Pin 3 (-)

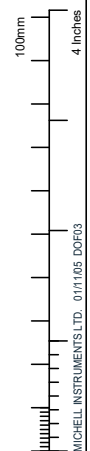
3rd ANGLE PROJECTION	TOLERANCES: UNLESS OTHERWISE STATED	DRAWING UNITS	SCALE	QFS	IMA
	0 DEC. PLACE: ±0.5 HOLE Ø: -0.0	mm	NTS	08	02/11/17
	1 DEC. PLACE: ±0.2 ANGLES: ±0.5°			07	16/12/13
	2 DEC. PLACE: ±0.1			06	06/04/11
				05	15/06/09
				04	25/03/08
				03	16/06/08
				ISSUE MOD. No.	DATE
				SIGN	
TITLE			DRAWING NUMBER		
EASIDEW I.S. & EASIDEW PRO I.S. DEWPOINT TRANSMITTER SYSTEM DRAWIN. QPS			Ex90385QPS		
USED ON			SHEET 1 OF 1 A3		
MICHELL INSTRUMENTS LTD. CAMBRIDGE ©					

THIS DOCUMENT IS THE PROPERTY OF MICHELL INSTRUMENTS LTD. AND MUST NOT BE COPIED NOR DISCLOSED TO A THIRD PARTY WITHOUT THE CONSENT OF MICHELL INSTRUMENTS.

DATE: 10/03/06

CHECKED: MSB

APPROVED: DATE



# Appendix E

## Quality, Recycling & Warranty Information

## Appendix E      Quality, Recycling & Warranty Information

Michell Instruments is dedicated to complying to all relevant legislation and directives. Full information can be found on our website at:

**[www.ProcessSensing.com/en-us/compliance/](http://www.ProcessSensing.com/en-us/compliance/)**

This page contains information on the following directives:

- Anti-Facilitation of Tax Evasion Policy
- ATEX Directive
- Calibration Facilities
- Conflict Minerals
- FCC Statement
- Manufacturing Quality
- Pressure Equipment Directive
- REACH
- RoHS
- WEEE
- Recycling Policy
- Warranty and Returns

This information is also available in PDF format.

# Appendix F

## Return Document & Decontamination Declaration

Appendix F Return Document & Decontamination Declaration

**Decontamination Certificate**

**IMPORTANT NOTE: Please complete this form prior to this instrument, or any components, leaving your site and being returned to us, or, where applicable, prior to any work being carried out by a Michell engineer at your site.**

Instrument			Serial Number	
Warranty Repair?	YES	NO	Original PO #	
Company Name			Contact Name	
Address				
Telephone #			E-mail address	
Reason for Return /Description of Fault:				
Has this equipment been exposed (internally or externally) to any of the following? Please circle (YES/NO) as applicable and provide details below				
Biohazards			YES	NO
Biological agents			YES	NO
Hazardous chemicals			YES	NO
Radioactive substances			YES	NO
Other hazards			YES	NO
Please provide details of any hazardous materials used with this equipment as indicated above (use continuation sheet if necessary)				
Your method of cleaning/decontamination				
Has the equipment been cleaned and decontaminated?			YES	NOT NECESSARY
Michell Instruments will not accept instruments that have been exposed to toxins, radio-activity or bio-hazardous materials. For most applications involving solvents, acidic, basic, flammable or toxic gases a simple purge with dry gas (dew point <-30°C) over 24 hours should be sufficient to decontaminate the unit prior to return. <b>Work will not be carried out on any unit that does not have a completed decontamination declaration.</b>				
<b>Decontamination Declaration</b>				
I declare that the information above is true and complete to the best of my knowledge, and it is safe for Michell personnel to service or repair the returned instrument.				
Name (Print)			Position	
Signature			Date	





[www.ProcessSensing.com](http://www.ProcessSensing.com)