

Tension Load Cell

>Model TS21

Crane Weighing, Tower Testing,
Tension Load cell.

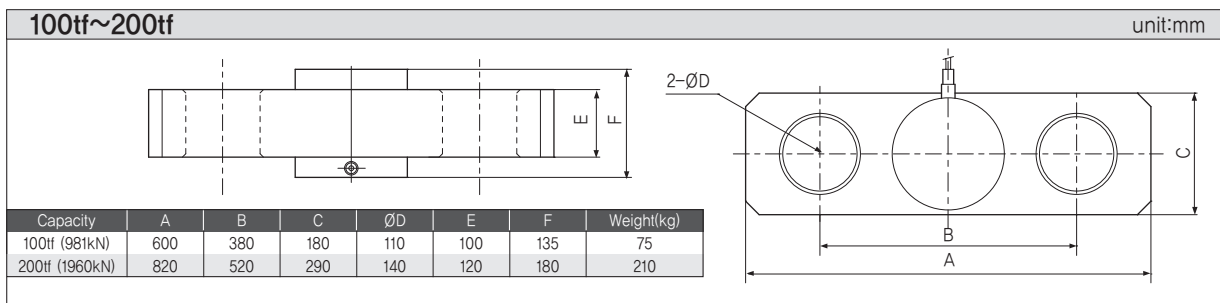
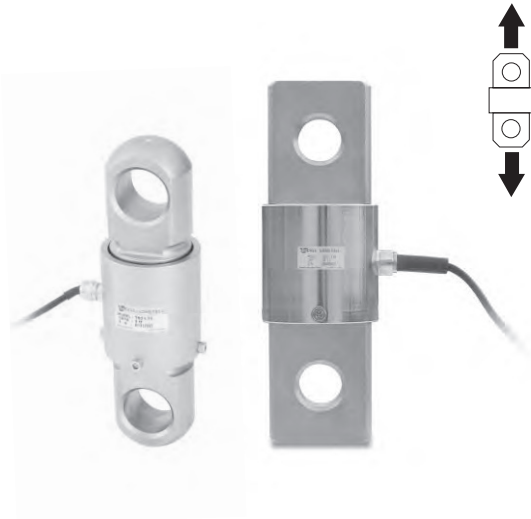
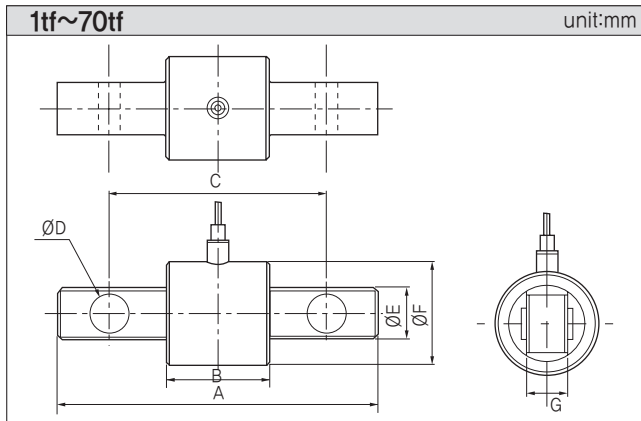

>SPECIFICATIONS

Specifications	Accuracy
Rated capacity(R.C.)	1tf, 2tf, 3tf, 5tf, 10tf, 20tf, 30tf, 50tf, 70tf, 100tf, 200tf
Rated output(R.O.)	1mV/V±0.5%
Nonlinearity	0.5% of R.O.
Repeatability	0.1% of R.O.
Hysteresis	0.1% of R.O.
Zero balance	±1% of R.O.
Terminal resistance input	350±10Ω
Terminal resistance output	350±5Ω
Insulation resistance bridge/case	2000MΩ
Temperature range, compensated	-10~60°C
Temperature range, safe	-20~80°C
Temperature effect, on rated output	0.1% of R.O./10°C
Temperature effect, on zero balance	0.05% of LOAD/10°C
Excitation recommended	10V
Safe overload	150% R.C.
Cable length	Ø7, 4core, 10m

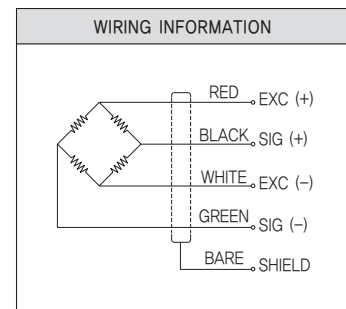

>DIMENSIONS TABLE

Capacity	A	B	C	ØD	ØE	ØF	G	Weight(kg)
1tf (9.81kN)	140	70	110	18	32	50	20	2
2tf (19.6kN)	163	70	120	22	39	50	25	
3tf (29.4kN)	180	63	128	27	49	60	30	3.5
5tf (49.0kN)	234	80	168	37	59	70	40	
10tf (98.1kN)	310	100	210	37	89	100	40	9
20tf (196kN)	400	120	285	62	120	135	70	23
30tf (294kN)	428	128	288	64	120	135	75	26
50tf (490kN)	508	148	342	75	145	160	98	43
70tf (686kN)	620	150	410	100	170	210	100	68

★Specifications are subject to change without notice.