

The following symbols in the Operating Instructions indicate safety precautions which must be strictly observed:



The instruments must only be disposed of in the correct way!

Operating Instructions

Passive DC signal isolator SINEAX SI 815-5



Camille Bauer Ltd.
Aargauerstrasse 7
CH-5610 Wohlen/Switzerland
Phone +41 56 618 21 11
Fax +41 56 618 35 35
info@camillebauer.com
www.camillebauer.com



SI 815-5 Be 974 180-02 10.10

Contents

1. Read first and then ...	1
2. Scope of supply	1
3. Brief description	1
4. Specification and ordering information	1
5. Technical data	2
6. Mounting	2
7. Electrical connections	3
8. Commissioning and maintenance	4
9. Releasing the signal isolator	4
10. Dimensional drawings	4
11. Declaration of conformity	4

1. Read first and then ...



The proper and safe operation of the device assumes that the Operating Instructions are **read carefully** and the safety warnings given in the sections

6. Mounting

7. Electrical connections

are **observed**.

The device should only be handled by appropriately trained personnel who are familiar with it and authorised to work in electrical installations.

Unauthorized repair or alteration of the unit invalidates the warranty.

2. Scope of supply

Signal isolator (Fig. 1)

1 Adapter (Fig. 1) for wall mounting

1 Operating Instructions (Fig. 2) in English, French, German

1 Ex approval (Fig. 2), only for Ex version devices



Fig. 1

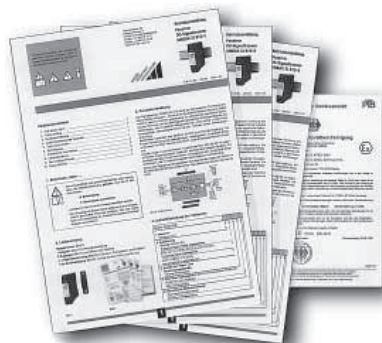

Fig. 2

3. Brief description

The signal isolator **SINEAX SI 815-5** serves to electrically insulate the 4...20 mA input circuit of a two-wire transmitter. It performs two tasks at the same time. Firstly it provides electrical insulation and secondly it conducts the power supply needed for measurement to the two-wire transmitter without injecting into the circuit itself. Thus the isolator does not require a power supply connection itself.

Some versions of the SINEAX SI 815-5 are **designed for FSK communication**. They are used in conjunction with "intelligent" two-wire transmitter which are capable of dialogue and operation according to the FSK principle and the HART or user-specific protocol.

The series also includes "intrinsically safe" versions [Ex ia] IIC with an intrinsically safe measurement/supply circuit. These operate in conjunction with intrinsically safe two-wire transmitters located in explosion hazard areas.

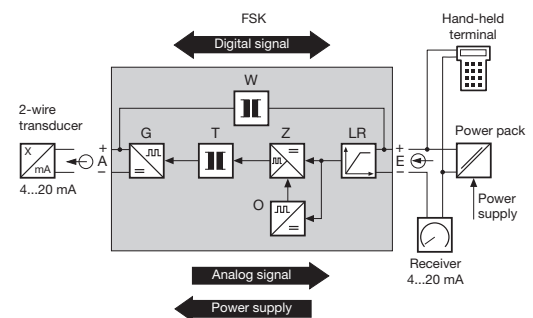

Fig. 3. Block diagram.

4. Specification and ordering information

Order Code	815 - 5 . 1 . .
1. Mechanical design Housing N17	5
2. Version Standard (non-Ex) Output signal non-intrinsically safe	1
[Ex ia] IIC, Output signal intrinsically safe	2
3. Number of isolation and transmission channels 1 channel (interface)	1
4. Field communications protocol Without FSK communication	0
With FSK communication	1
5. Climatic rating Standard climatic rating	0
Improved climatic rating	1

5. Technical data

Input signal E¹

(Input circuit between signal isolator and power pack)

DC current signal I_E: 4...20 mA

Voltage U_E: 12...30 V DC

Overload capacity: ≤ 50 mA continuous

Output signal A¹

(Input circuit between signal isolator and 2-wire transmitter)

DC current signal I_A: 4...20 mA

Voltage U_A (for I_E = 20 mA and U_E = 22 V):

> 19.3 V	with standard (non-Ex) version, not designed for communications protocol
> 18.5 V	with standard (non-Ex) version, designed for FSK communication
> 14.3 V	with Ex versions, not designed for communications protocol
> 13.3 V	with Ex versions, designed for FSK communication

Voltage drop U_V = U_E - U_A (at U_E) 12...22 V:

< 2.7 V	with standard (non-Ex) version, not designed for communications protocol
< 3.5 V	with standard (non-Ex) version, designed for FSK communication
< 7.7 V	with Ex versions, not designed for communications protocol
< 8.7 V	with Ex versions, designed for FSK communication

Residual ripple: < 20 mV ss (120 kHz)

Time constant: Approx. 5 ms

Accuracy data

Error: < ± 0.2%
(Reference value 20 mA of output signal,
including typical linearity error < ± 0.1%)

Ambient conditions

Climatic rating: Climate class 3Z acc. to VDI/VDE 3540

Operating temperature: - 25 to +55 °C
- 20 to +55 °C
(for the Ex versions: output signals "intrinsically safe")

Storage temperature: - 40 to +70 °C

Annual mean relative humidity: ≤ 75% standard climatic rating
≤ 95% improved climatic rating

Seismic test: 5 g, < 200 Hz, 2 h in each of 3 directions

Shock test: **50 g**, 10 shocks in each of 3 directions

Altitude: 2000 m max.

Indoor use statement!

6. Mounting

The SINEAX SI 815-5 can be mounted either on a top-hat rail or directly onto a wall or mounting plate using the adapter (standard accessory).



Make sure that the ambient temperature stays within the **permissible limits**:

- 25 and + 55 °C for standard instruments
- 20 and + 55 °C for instruments in **Ex** version!

6.1 Top-hat rail mounting

Simply clip the device onto the top-hat rail (EN 50 022) (see Fig. 4).

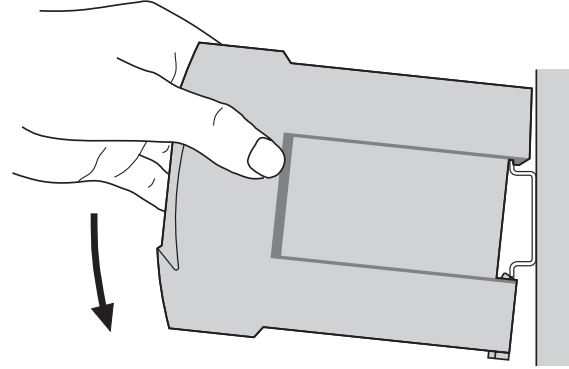

Fig. 4. Mounting on top-hat rails 35 x 15 or 35 x 7.5 mm.

6.2 Wall mounting

Drill 2 holes in the wall or panel as shown in the drilling pattern (Fig. 5). Now secure the adapter (standard accessory) to the wall or panel using two 5 mm diameter screws (Fig. 6). Clip the device onto the adapter (Fig. 7).

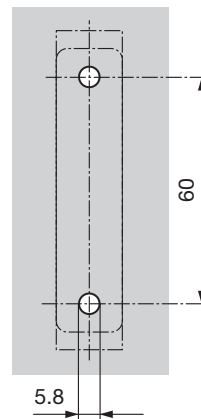

Fig. 5. Drilling pattern.

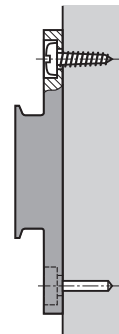

Fig. 6. Adapter mounted on wall.

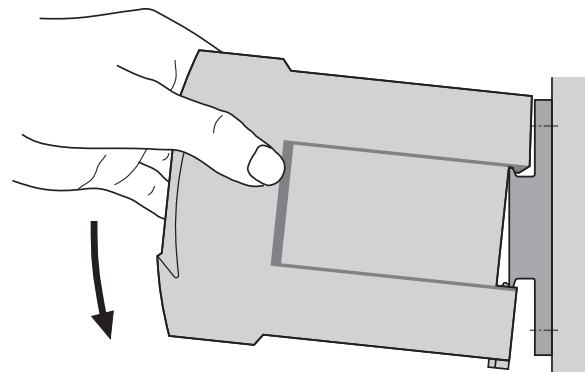
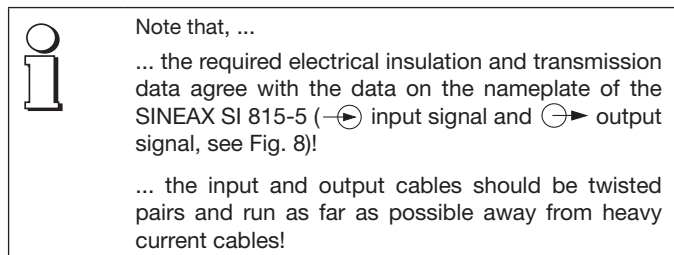
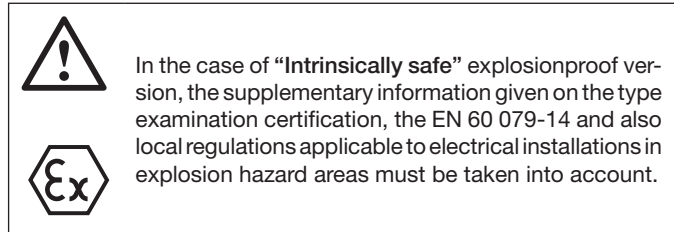
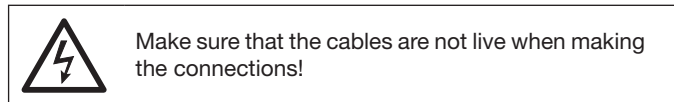

Fig. 7. Mounting on the adapter.

¹ "Input" and "output" in this case refer to the direction of power supply flow.

7. Electrical connections

The electrical connections are made to screw terminals which are easily accessible from the front of the signal isolator (see Fig. 9) and can accommodate wire gauges up to 2,5 mm².



SINEAX SI 815	Passiver DC-Signaltrenner Passive DC signal isolator	Camille Bauer AG Aargauerstr. 7 CH-5610 Wohlen Switzerland
Type: 815 - 51110		
Mat: 999295/1416280		Manufactured: 1998
	Tamb 55°C	
4...20 mA 12V/30V HART 4...20 mA		

Fig. 8. Example of a nameplate.

Connect the input E and output A leads and according to Fig. 9.

Signal isolator in housing N17 with one isolation and transmission channel

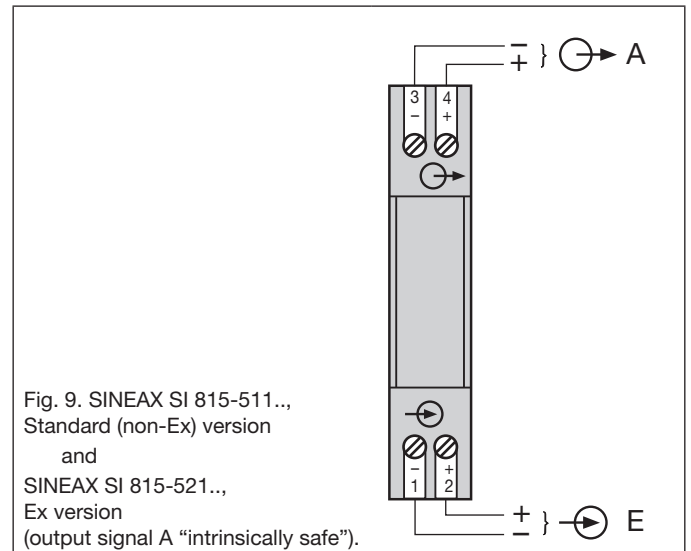
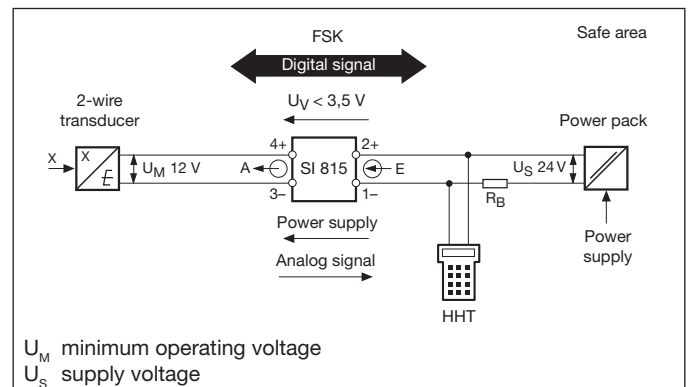
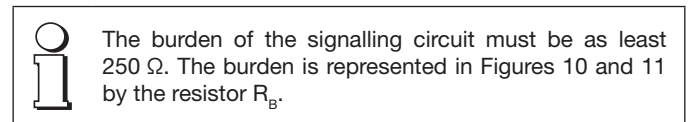

Fig. 9. SINEAX SI 815-511... Standard (non-Ex) version and SINEAX SI 815-521... Ex version (output signal A "intrinsically safe").

7.1 Connection of the hand-held-terminals HHT

The FSK transmission versions of the isolation transformers SINEAX SI 815-5111. and SI 815-5.11. can relay a frequency modulated digital signal in both directions in addition to the analog signal and the auxiliary supply. Connect the hand-held terminal HHT as shown in Figures 10 and 11.



U_M minimum operating voltage
 U_S supply voltage

Fig. 10. SINEAX SI 815-5111. Standard (non-Ex) version, designed for FSK communication, frequency 500 Hz ... 35 kHz.

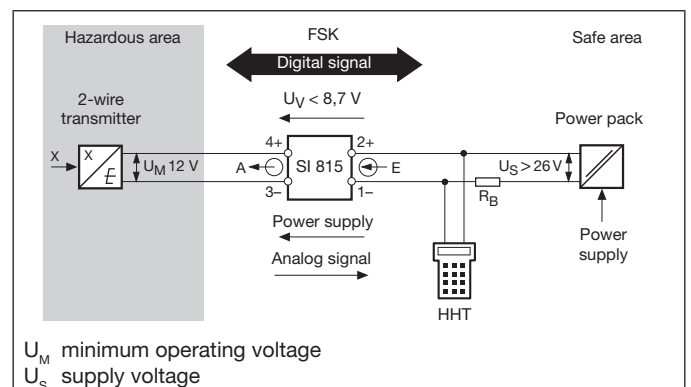

U_M minimum operating voltage
 U_S supply voltage

Fig. 11. SINEAX SI 815-5.11. Ex version, (output signal A "intrinsically safe"), designed for FSK communication, frequency 500 Hz ... 35 kHz.

8. Commissioning and maintenance

The device is in operation as soon as the input signal E is connected.

The signal isolator requires no maintenance.

9. Releasing the signal isolator

Release the signal isolator from a top-hat rail as shown in Fig. 12 or from the adapter as shown in Fig. 13.

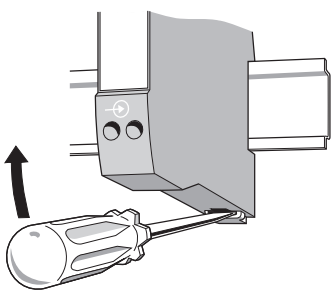

Fig. 12

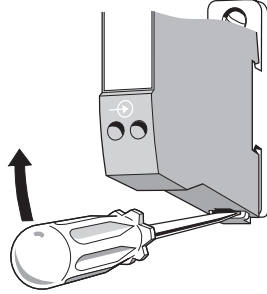

Fig. 13

10. Dimensional drawings

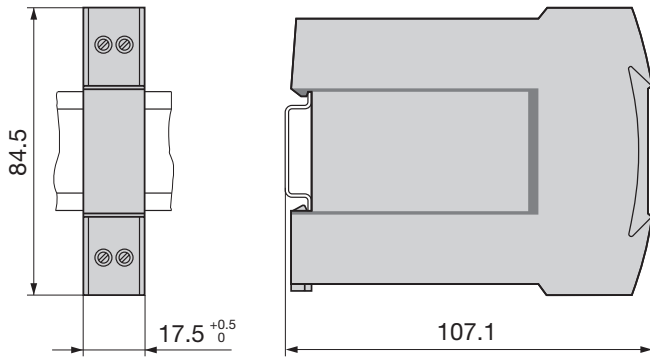

Fig. 14. SINEAX SI 815-5.... (housing N17) clipped onto a top-hat rail (35 × 7.5 or 35 × 15 mm, acc. to EN 50 022).

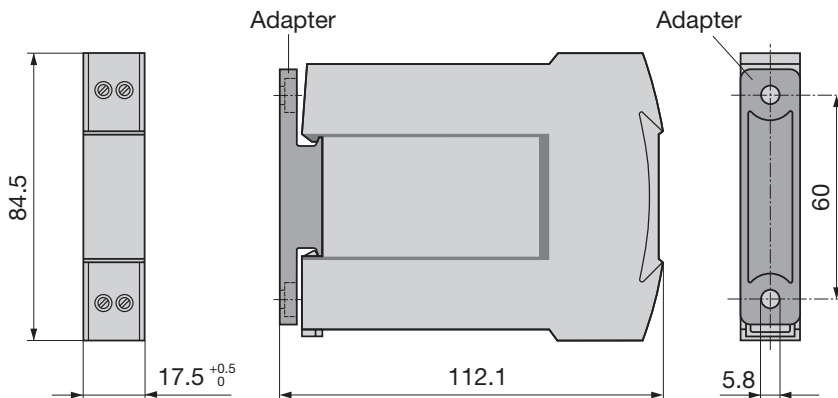

Fig. 15. SINEAX SI 815-5.... (housing N17) with adapter for wall mounting.

11. Declaration of conformity



EG - KONFORMITÄTSERKLÄRUNG **CAMILLE BAUER**
DECLARATION OF CONFORMITY

Dokument-Nr./ Document No.: SI 815_CE-konf.DOC

Hersteller/ Manufacturer: **Camille Bauer AG**
Switzerland

Anschrift / Address: **Aargauerstrasse 7**
CH-5610 Wohlen

Produktbezeichnung/ Product name: **Passiver DC- Signaltrenner**
Passive DC signal isolator

Typ / Type: **SINEAX SI 815**

Das bezeichnete Produkt stimmt mit den Vorschriften folgender Europäischer Richtlinien überein, nachgewiesen durch die Einhaltung folgender Normen:

The above mentioned product has been manufactured according to the regulations of the following European directives proven through compliance with the following standards:

Nr. / No.	Richtlinie / Directive
2004/108/EG 2004/108/EC	Elektromagnetische Verträglichkeit - EMV - Richtlinie Electromagnetic compatibility - EMC directive

EMV / EMC	Fachgrundnorm / Generic Standard	Messverfahren / Measurement methods
Störaussendung / Emission	EN 61000-6-4 : 2007	EN 55011 : 2007+A2:2007
Störfestigkeit / Immunity	EN 61000-6-2 : 2005	IEC 61000-4-2: 1995+A1:1998+A2:2001 IEC 61000-4-3: 2006+A1:2007 IEC 61000-4-4: 2004 IEC 61000-4-6: 2008

Nr. / No.	Richtlinie / Directive
2006/95/EG 2006/95/EC	Elektrische Betriebsmittel zur Verwendung innerhalb bestimmter Spannungsgrenzen - Niederspannungsrichtlinie - CE-Kennzeichnung : 95 Electrical equipment for use within certain voltage limits - Low Voltage Directive - Attachment of CE mark : 95

EN/Norm/Standard	IEC/Norm/Standard
EN 61 010-1 : 2001	IEC 1010-1 : 2001

Ort, Datum / Place, date: **Wohlen, 2.Oktober.2009**

Unterschrift / signature:

M. Ulrich

M. Ulrich
Leiter Technik / Head of engineering

J. Brem

J. Brem
Qualitätsmanager / Quality manager