

INSTRUCTIONS MANUAL

PTE-300-V

THREE PHASE RELAY TEST SET

REFERENCE: FAEVMV02

EDITION: 14/03/2011

VERSION: 4

“The priority of EUROS MC, S.A. is to obtain the highest standards and quality in all our products, serving to satisfy the expectations and necessities of our clients”.

INDEX

PTE-300-V CONTENTS LIST	5
1. INTRODUCTION	6
1.1. MAIN FUNCTIONAL FEATURES	6
1.2. APPLICATIONS	7
2. OPERATIONAL PRINCIPLES	9
2.1. GENERAL	9
2.2. FRONT PANEL CONTROLS	10
2.3. INTELLIGENT GENERATOR MODULE	11
2.4. POWER SUPPLY	12
3. CONTROLS DESCRIPTION	13
3.1. MAIN SUPPLY SECTION	13
3.1.1. MAIN VOLTAGE SUPPLY	13
3.1.2. FIXED 110 V c.a. VOLTAGE SUPPLY	14
3.2. FREQUENCY SECTION	14
3.2.1. CONTROL KEYS AND KNOBS	14
3.2.1.1. Mode funtion	14
3.2.1.2. Ramp parameters selection	15
3.2.1.3. Start the selected ramp	15
3.2.1.4. Regulation digit selection	15
3.2.1.5. Rotating control knob	15
3.2.2. DISPLAYS AND OPTIC INDICATORS	16
3.2.2.1. Function MODE indicators	16
3.2.2.2. Ramp indicators	16
3.2.2.3. Selection indicators	17
3.2.2.4. Selection display	17
3.2.3. CONNECTORS: Auxiliary Frequency Output	17
3.3. POWER OUTPUTS	18
3.3.1. LEVEL SECTION	19
3.3.1.1. CONTROL KNOBS AND PRESS KEYS	19
3.3.1.2. OPTICAL INDICATORS AND DISPLAYS	21
3.3.1.3. TAPS: Output taps	23
3.3.2. PHASE SECTION	24
3.3.2.1. CONTROL KNOBS AND PRESS KEYS	24
3.3.2.2. OPTICAL INDICATORS AND DISPLAYS	25
3.4. GENERAL CONTROL SECTIONS	26
3.4.1. CONTROL KEYS	26

3.4.1.1.	Reset	26
3.4.1.2.	Print	26
3.4.1.3.	RS-232 serial port control.....	26
3.4.1.4.	SYNCHRONIZATION.....	27
3.4.1.5.	MASTER/SLAVE control	27
3.4.2.	OPTIC INDICATORS.....	27
3.4.2.1.	RS-232 port indicator.....	27
3.4.2.2.	SYNCHRONIZING REFERENCE indicators.....	27
3.4.2.3.	Monitor state indicator	28
3.4.3.	CONNECTORS AND FUSES.....	28
3.4.3.1.	Monitor input taps	28
3.4.3.2.	Auxiliary output to start an external timer	28
3.4.3.3.	RS-232 connector.....	29
4.	FUNCTIONS: USE AND DESCRIPTIONS	30
4.1.	FREQUENCY SECTION.....	30
4.1.1.	INITIAL STATUS.....	30
4.1.2.	FUNCTION MODE SELECTION	30
4.1.2.1.	NORMAL FREQUENCY MODE (F)	30
4.1.2.2.	SLIP FREQUENCY MODE (ΔF).....	31
4.1.3.	DYNAMIC TEST: SELECTING FREQUENCY RAMPS	31
4.1.4.	DYNAMIC TEST: START THE SELECTED RAMP.....	32
4.1.5.	DYNAMIC TEST: STEP TO 2 ND VALUE.....	32
4.1.6.	TTL AUXILIARY OUTPUT: CHARASTERISTICS AND APPLICATIONS.....	32
4.2.	LEVEL SECTION: OUTPUT POWER.....	32
4.2.1.	INITIAL STATUS.....	33
4.2.2.	OUTPUT MODE SELECTION (V/I)	33
4.2.3.	OUTPUT RANGE SELECTION	33
4.2.4.	REFERENCE SOURCE SELECTION.....	33
4.2.5.	OUTPUT VALUES SELECTION.....	34
4.2.6.	OUTPUT CONTROL: ON/OFF AND ALARMS	34
4.2.7.	DYNAMIC TESTS: STEP TO 2 ND VALUE	35
4.3.	PHASE ANGLE SELECTION	35
4.3.1.	PHASE ANGLE SENSE	35
4.3.2.	DYNAMIC TESTS: STEP TO 2 ND VALUE	37
4.3.3.	USE OF EXTERNAL REFERENCE INPUT	37
4.4.	GENERAL CONTROL SECTION	38
4.4.1.	SIGNAL MONITOR.....	38
4.4.2.	USE OF THE MASTER/SLAVE PRESS KEY	38
4.5.	COMMUNICATION IN BUS-PTE.....	39
4.5.1.	EVENTS IN BUS-PTE	39

4.5.2. EVENT TRANSMITTED BY A PTE-300-V	40
4.6. SPECIAL FUNCTIONS	40
4.6.1. AUTO OFF	40
4.6.2. FAILURES DETECTION.....	41
5. SPECIFICATIONS	43
5.1. FREQUENCY GENERATOR	43
5.2. POWER GENERATORS.....	44
5.3. EXTERNAL REFERENCE INPUT	45
5.4. SIGNAL MONITORS.....	45
5.5. AVAILABLE REFERENCES	45
5.6. CONTAINER	45
6. TECHNICAL ASSISTANCE, AFTER SALES SERVICE AND WARRANTY	46
6.1. WARRANTY	46
6.2. AFTER SALES SUPPORT	46
6.3. OTHER EUROSMC PRODUCTS.....	46

FIGURES INDEX

Figure 1: <i>PTE-300-V Front Panel</i>	9
Figure 2: <i>Functional Modules</i>	10
Figure 3: <i>Front Module</i>	11
Figure 4: <i>Intelligent Generator Module</i>	12
Figure 5: <i>Main Supply</i>	13
Figure 6: <i>Frequency Section</i>	14
Figure 7: <i>Power Output</i>	18
Figure 8: <i>Level Selection</i>	19
Figure 9: <i>Phase Angle Selection</i>	24
Figure 10: <i>General Control Sections</i>	26
Figure 11: <i>Signal Monitor</i>	28
Figure 12: <i>Frequency Ramp Selection</i>	31
Figure 14: <i>Phase Angle Selection (European)</i>	36
Figure 15: <i>Phase Angle Selection (American)</i>	36

PTE-300-V CONTENTS LIST

1	Unit PTE-300-V.
1	Nylon cover.
1	Voltage supply cable type Schuko.
12	Interconnection cables 2.5 mm ² section (6 reds and 6 blacks).
1	Interconnection cable between PC and PTE-300-V unit, by RS-232.
1	Cable de interconexión entre dos equipos por BUS PTE.
1	Interconnection cable for frequency external output PTE-300-V type BNC.
6	Clips up to 50 A (3 reds and 3 blacks).
6	Clips up to 10 A (3 reds and 3 blacks).
1	Set of spare fuses.
1	Case key.
1	Warranty.
1	Measurement Certificate.
1	Instructions Manual.

1. INTRODUCTION

The PTE-300-V is designed as a **Portable Three Phase Unit** that allows the user to test, as stand alone unit or in combination with others, all type of protective relays.

Extremely compact and rugged, this unit incorporates the latest in the modern microprocessor technology to achieve unbeatable output characteristics in terms of power, accuracy, low distortion, and dynamic capability. This technology allows the unit to perform, without any external accessories, various specific functions very often used in the relay testing.

All the output signals are digitally generated, amplified and controlled by the internal IGM's (Intelligent Generation Modules) in terms of amplitude, phase and frequency. A high accuracy and stability are obtained in the output waveforms, which are absolutely independent of the main supply.

Contained in an aluminum IP-65 case, with a membrane keyboard that allows full manual control, and a RS-232 com port for computer control, the PTE-300-V offers the best features actually available for on site manual or automatic relay testing.

1.1. MAIN FUNCTIONAL FEATURES

The following are the more outstanding functions/features that the PTE-300-V has:

a) INTERNAL FREQUENCY GENERATOR

Allows the user to work in any frequency between 40 and 300 Hz. Also, frequency ramps and steps can be easily preprogrammed from the front panel controls allowing testing the most complex frequency, harmonics and synchronizing relays. The differential mode allows regulating frequency differences respect to an *Extern Reference*, with a resolution of 1 mHz.

b) AVAILABLE REFERENCES

The power output has **four different references** available:

- Internal Frequency Generator (Freq.).
- The main supply phase (*Line*).
- The PTE BUS (BUS).
- The *External Phase Reference* (current or voltage).

c) POWER OUTPUTS

The **voltage or current outputs** are available, **up to 300 V** in three ranges and **up to 8 A** in two ranges respectively.

Any power outputs combination is possible: two channels can work in voltage mode and the other one in current mode, or even all of them can work in current mode. In current mode, the unit allows channels parallel connection so it can supply up to $3 \times 8 \text{ A} = 24 \text{ A}$.

All the outputs have a **dynamic capability**. The output **regulation** can work **independently or linked in a three phase system**, when PTE units are working together interconnected through

the PTE BUS, any combination of dynamic steps to 2nd values, can be selected in amplitudes and phase angles for any type of fault simulation.

d) EXTERNAL REFERENCES INPUT

Can be synchronized, in terms of frequency and phase with any external signal, **from 0.1 to 25 A** in current, and **from 5 to 300 V** in voltage.

e) SIGNAL MONITOR

The unit has a *Signal Monitor* input that can work with dry contacts or with voltage signals from 5 to 250 V ac or dc.

f) RS-232 COM PORT

Used to control the equipment from an external computer, can be used to perform the following:

- Software calibration.
- Automatic testing.
- Direct printing of the test results in a RS-232 input printer.

g) PTE BUS

Allows the interconnection with any other unit of the PTE RANGE.

h) EXTERNAL TIMER CONTROL OUTPUT

Delivers a pulse signal, dry contact type, of 20 ms duration. This can be used to start an external timer, for timing measurements. This signal is produced every time one of the power outputs changes its status, or the *Step* key is activated in amplitude or in phase.

i) OUTPUT PROTECTION

The outputs and, in general, the unit, are electronically protected against overload, short-circuit and over temperature. These alarms are indicated on the *Front Panel*.

Standard 5 x 20 mm fuses protect the rest of inputs and general devices included in the unit.

1.2. APPLICATIONS

a) AS STAND ALONE TESTING UNIT

- Frequency relays.
- Load sharing relays.
- Synchronizing relays.
- Multifunction generator protection relays.
- Harmonics relays.
- Overcurrent relays (up to 24 A).
- Inverse time overcurrent relays.
- Definite time overcurrent relays.

- Earth and neutral (including harmonics filtering).
- Voltage controlled relays.
- Directional relays.
- Differential relays.
- Single phase distance relays.
- Three-phase distance relays (open delta).
- Directional power relays (single and three-phase).
- Maximum and minimum voltage relays.
- Dynamic test: fault simulation.

b) COMBINED WITH A SINGLE PHASE CURRENT INJECTOR

- Three-phase distance relays.
- Full three-phase network fault simulation.
- In general all types of relays which require 3 voltages and 3 currents to function correctly.

c) MISCELLANEOUS

Due to its good characteristics of accuracy and stability, the PTE-300-V can test transducers, energy meters and measuring instruments can be tested as well, in the following range:

- Voltage in three-phase or single phase (up to 300 V).
- Three phase current up to 8 A (or 24 A single phase).
- Frequency between 40 and 300 Hz.
- Three-phase angle from 0° to 359.9°.

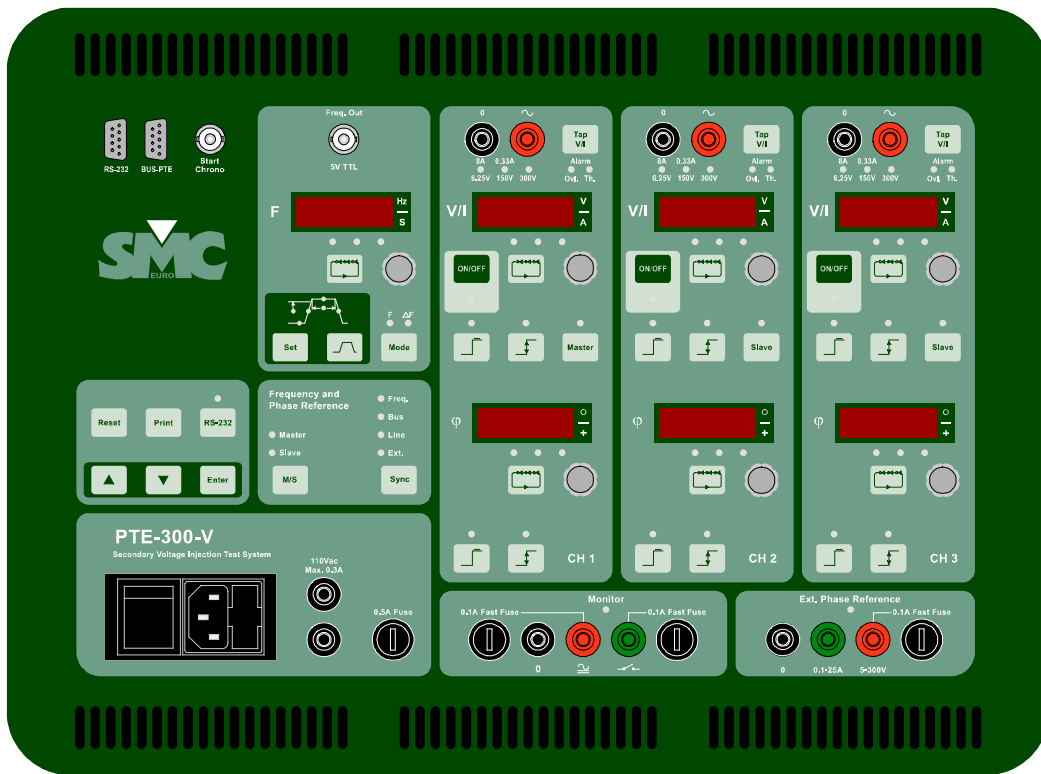

Figure 1: PTE-300-V Front Panel

2. OPERATIONAL PRINCIPLES

2.1. GENERAL

In this section a general overview of the operational basic principles on which the PTE-300-V is based, are given in this section. An understanding of these principles should help in order to find new applications, maintenance, etc.

Briefly, the unit has a user interface (Front Panel), that is communicated with the *Power Amplifier* through the microprocessors incorporated. Of course, a power supply, security devices, transformers, etc. need to be used as well. According with these, the unit can be divided in the following modules:

1. *Front Panel Controls.*
2. *Intelligent Generator Modules (IGM).*
3. *Power Supply.*

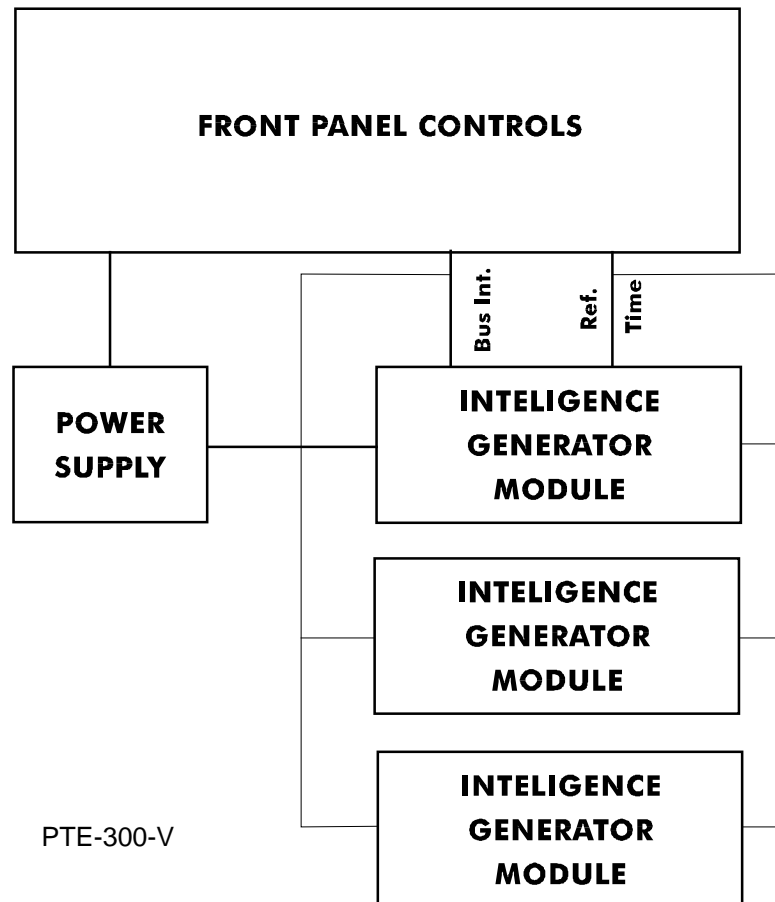
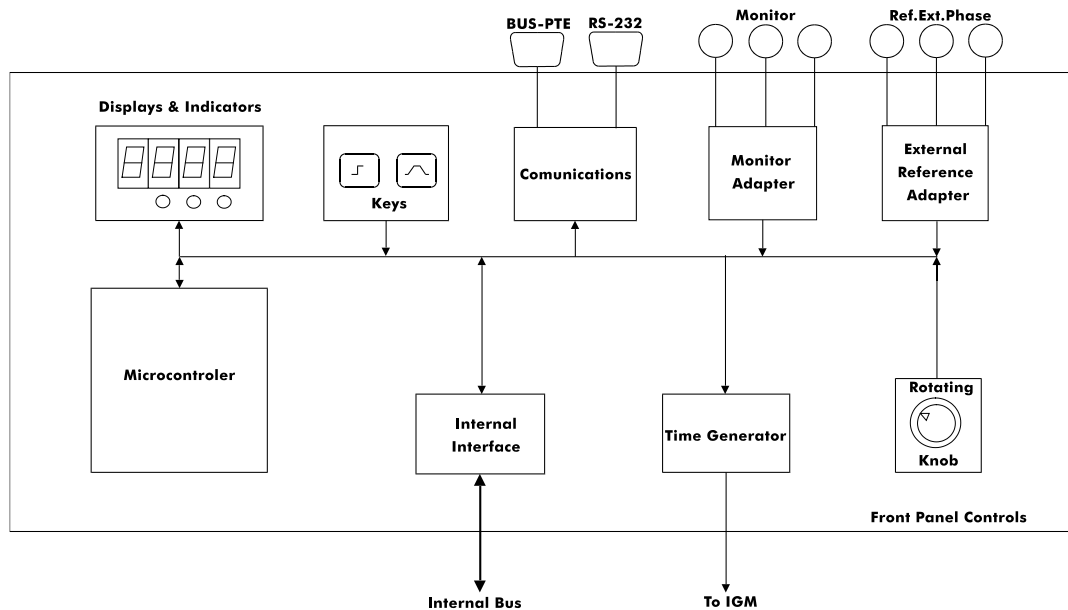

Figure 2: Functional Modules

2.2. FRONT PANEL CONTROLS

Allows the user to communicate with the power output section of the unit in a manual way, or using a software program. To achieve this, it has the following sections:

1. **Displays and LED indicators:** indicate the various selections made by the operator and the status of the unit.
2. **Press key controls:** this is a membrane keyboard with acoustic feedback, in which the various different functions available in the unit are selected.
3. **Multi-turn control knobs:** these are rotative pulse generators that are used to make the different selections desired on the displays indicators, in an easy and fast manner.
4. **Monitor taps:** contain the circuits to detect the status of the signals applied in these taps.

Figure 3: *Front Module*

5. **External Reference Taps:** contain the circuits to synchronize the power outputs to the phase and frequency signals connected to these taps.
6. **Communications:** the PTE units have the capability to communicate with some external control devices by RS-232 (allowing the user for printing results and calibration from the PC) and by BUS-PTE, for interconnection with PTE RANGE units and control of these by a PC.
7. **Internal Bus Interface:** establishes the communication between the *Front Panel* and the *Intelligent Generator Module*, via the microprocessors included in both.
8. **Time Generator:** it generates the high accuracy time reference necessary to generate the internal phase and frequency.
9. **Output taps:** these are the taps of the auxiliary voltage supply of 110 V ac, the power output taps, and the tap to start an external timer.
10. **Microcontroller:** it is one of the most important parts of the unit, which as its name indicates, controls or establishes the flow of information between all the functional blocks previously mentioned.

2.3. INTELLIGENT GENERATOR MODULE

Essentially, the IGM is a linear power amplifier, controlled by its internal microprocessor. It produces the sinusoidal signal in the frequency and the phase selected. This is amplified and adapted by a transformer in the selected output range. This generator also feedbacks the output level in voltage, current, and phase, to the generation stage, thus achieving a high accuracy output.

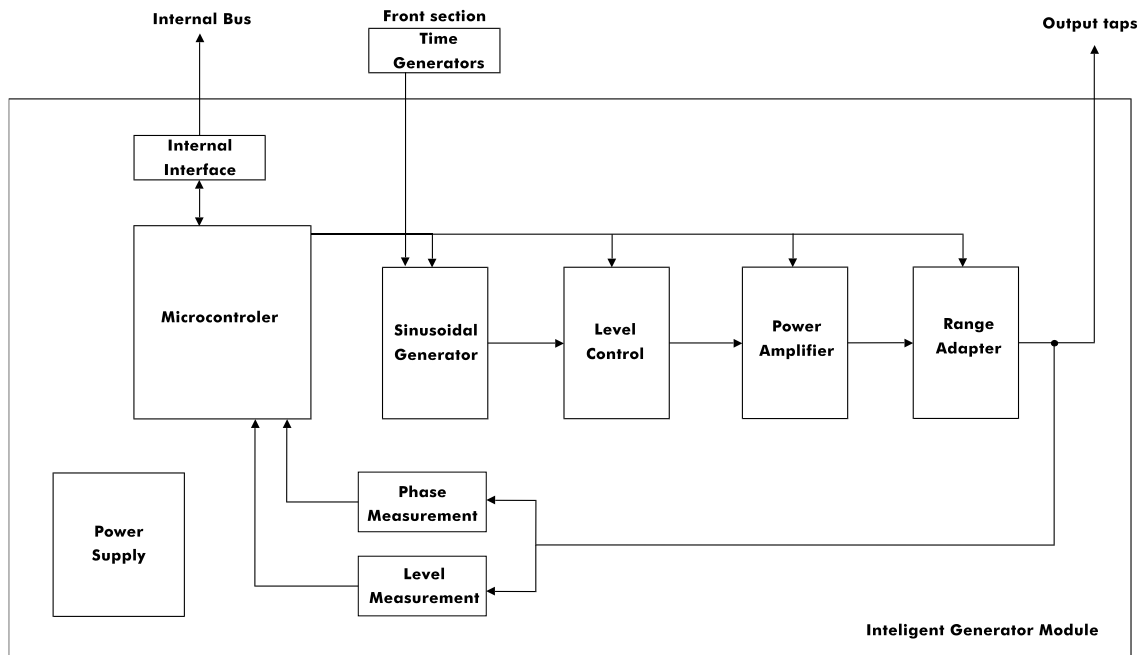

Figure 4: *Intelligent Generator Module*

As shown in the block drawing and in the front panel control functions, a microprocessor is in charge of supervising all the functions of the generator modules. These receive the output measurements and make the corrections necessary in amplitude and phase to obtain the desired accuracy. Also they store the calibration parameters, and use them to correct the selections made from the *Front Panel*.

2.4. POWER SUPPLY

As in all off the systems that produce an output which is absolutely independent of the main supply, the PTE-300-V needs to have a D.C. power supply, that converts the AC input of the main supply, to a DC that supplies the power amplifiers. This is achieved by using a combination of switching and linear DC power supplies.

3. CONTROLS DESCRIPTION

This section describes one by one and in detail all of the controls, indicators, displays, and connection taps on the front panel of the PTE-300-V. As well as the functions, marked indications and where they are located will be shown in the figures.

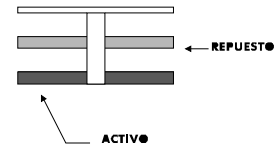

To understand this clearly, sections will describe the controls, by their functions, and by their physical position on the front panel. The different types of controls that you can find are classified as follows:

- **KEY CONTROLS:** this refers to the press key and rotating knobs.
- **DISPLAY AND OPTIC INDICATORS:** this refers to the LED indicators and the selection displays.
- **CONNECTORS (TAPS):** this refers to all taps (input and output), connectors, etc., which are contained in the PTE-300-V. This section describes all the connectors that are incorporated in the unit. All of them meet international safety standards and are easily identified with their corresponding identification marks on the front panel.

3.1. MAIN SUPPLY SECTION

3.1.1. MAIN VOLTAGE SUPPLY

The unit is supplied with SCHUKO type plug 2 poles with earth. Also incorporated in the connector is a filter to avoid perturbations from the main supply.

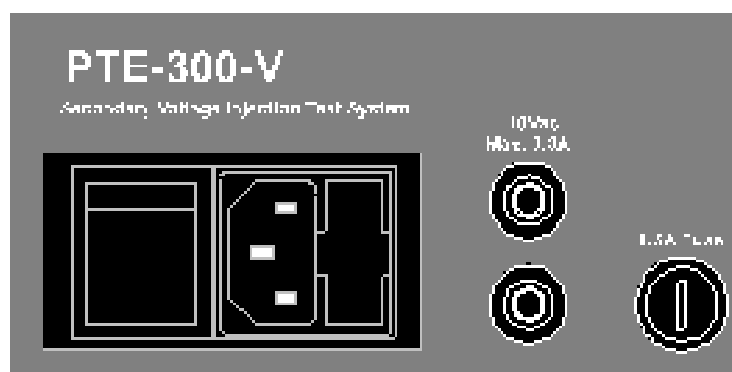
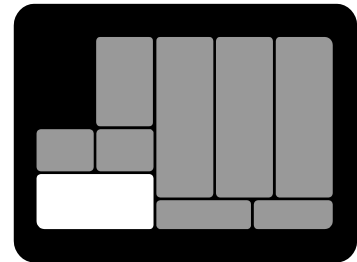

Figure 5: Main Supply

This is situated on the bottom left hand side of the unit and includes the following:

- Power supply with 2 poles and earth.

- Power supply fuse holder: to reach these fuses, the cover must be lifted as indicated in the drawing. There are two fuses: the lower one is the active fuse and the one located above is the spare fuse. The fuses are standard type, 5 x 20 mm, 10 A.
- Power supply switch: it has 2 positions, ON/OFF. The unit is disconnected when the red mark of the switch is visible.

3.1.2. FIXED 110 V c.a. VOLTAGE SUPPLY

This output is located in the lower central section to the right of the power supply switch. It consists of 2 black taps.

This output is always active when the unit is switched on. The taps have a distance of 19 mm which is the standard two-pole plug size.

3.2. FREQUENCY SECTION

This section is located on the left-hand side of the unit and is clearly marked. Contains all the control knobs, keys, and LEDs necessary for the operator to use the frequency functions described in this section.

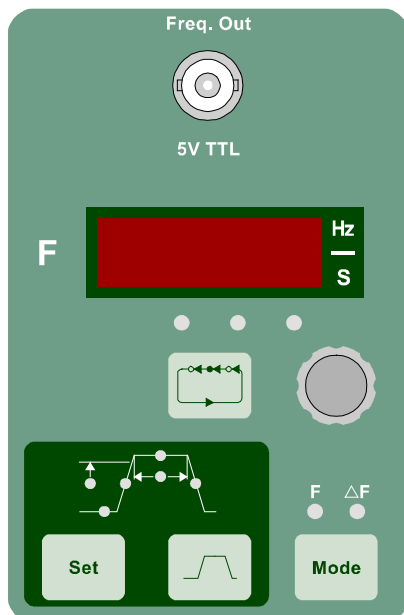
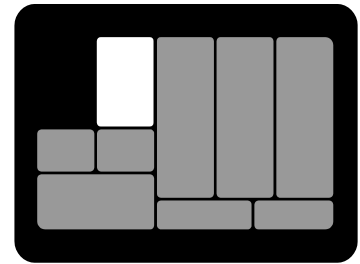

Figure 6: *Frequency Section*

3.2.1. CONTROL KEYS AND KNOBS

3.2.1.1. Mode function



This key works in a sequential way, when this key is pressed the LEDs will indicate the option selected. The two options are:

1. Normal frequency mode (F).



2. Slip frequency or relative frequency mode (ΔF).

3.2.1.2. Ramp parameters selection

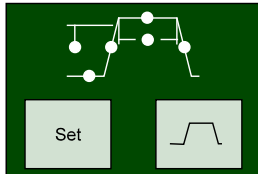

The SET key works in a sequential way. It is associated with 6 LED indicators. Each time this key is pressed it allows introducing a different ramp parameter. The associated LED will indicate which one is being selected. The ramp parameters available are as follows:

- Initial frequency value for the 1st ramp (Hz). This value acts as the final value for the 2nd ramp.
- Frequency slope for the 1st ramp (Hz/s).
- Time duration that the final value of the 1st ramp remains before the beginning of the 2nd ramp (s).
- Final frequency value for the 1st ramp (Hz).). This value acts as the first value for the 2nd ramp.
- Frequency slope for the 2nd ramp (Hz/s).
- It is possible to select a frequency value, on which a pulse of 20 ms duration is produced at the *Start Chrono* output (Hz).

3.2.1.3. Start the selected ramp

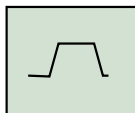

This key starts the ramp previously selected by pressing the key. This ramp will stop when it arrives to the programmed cycle or when there is a signal in the monitor taps.

3.2.1.4. Regulation digit selection

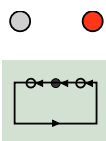

This key works in a sequential way and it is associated with 3 LEDs located above this press key. This allows the operator to select the output in a fine or course regulation, by changing the digit to be adjusted.

The following resolutions can be obtained:

- 1 digit.
- 10 digits.
- 100 digits.

When pressing this key for more than 2 seconds, it will block the rotating pulse generator, not allowing any modifications to the level selected.

3.2.1.5. Rotating control knob

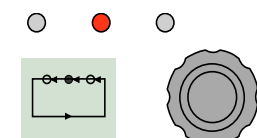

This is a rotating pulse generator and has step by step sensation. The values can be increased or decreased by turning this control knob

clockwise or anti-clockwise by one digit per step, according to the selected digit weight as described previously.

This knob has no end and can be controlled at any speed. However if the control knob is turned very fast the value will change at a maximum rate of 1 digit per second.

3.2.2. DISPLAYS AND OPTIC INDICATORS

3.2.2.1. Function MODE indicators



These two 3mm LED (red), one will always be lit and indicates the frequency mode function that is actually selected.

Mode

They are associated with the press key MODE.

3.2.2.2. Ramp indicators

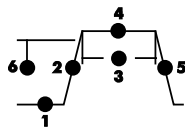

They are six 2 mm red LEDs, which indicate the situation of the ramp, in the selection level and when it is active. They have 2 different function modes:

1. Permanently lit: this indicates the selection mode. In this situation the operator can select new values, which will be shown in the frequency display. At this stage the selected values are not in the output. The relationship between the LEDs and the parameters that can be selected is as follows:

LED 1: Indicates that the initial value of the first ramp can be selected. The value will be shown in the display in Hz.

LED 6: Indicates that the *Start Chrono* frequency value can be selected. The value will be shown in the display in Hz.

LED 2: Indicates that the frequency slope (rate of change) for the 1st ramp, from the initial to the final value can be selected. It is in Hz per second, (Hz/s). If 0 is selected the equipment will go directly (step) to the final value.

LED 4: Indicates that the final value of the 1st ramp can be selected. The value will be shown in the display in Hz.

LED 3: It indicates that you can select the time duration in which the unit will remain in the final value before starting the 2nd ramp. This value will be shown in the display in seconds (s). When 0 is selected the unit will maintain the final value indefinitely.

LED 5: Indicates that the frequency slope (rate of change) for the 2nd ramp, from the final to the initial value can be selected. It is in Hz per second, (Hz/s). If 0 is selected the equipment will go directly (step) to the initial.

These LEDs are associated with the press key SET.

2. When flashing: this indicates that the ramp is active. When the *Ramp* key is pressed the ramp will start. The LEDs will pass in successive order, indicating the state of the equipment and the ramp in each moment.

3.2.2.3. Selection indicators

- These three, 3 mm LEDs (red), indicate the digit to be regulated. Only one will be lit and it will indicate the digit above it to be regulated

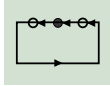

These LEDs are associated with the press key .

3.2.2.4. Selection display



The display is made up of 4 digits of 7 segments, red in color and 0.3 inches in height, which show the selected value, and the units of the parameter selected which are located to the right of the display.

It can work in three different modes:

- Hz (frequency).
- Hz/s (rate of change or slope).
- S (time duration in seconds).

When the output of the unit is not synchronized with this frequency generator, the display will show “----” instead of the selection made, and all the controls in the frequency section will be deactivated.

When working in the frequency ramp mode, and the *Signal Monitor* receives a signal (which indicates a relay trip) the frequency display will hold the frequency value at the time of the trip

3.2.3. CONNECTORS: Auxiliary Frequency Output

Freq. Out



5 V TTL

This is a BNC conector that can be used to obtain a square form wave, TTL level, exactly the same as the frequency being produced by the output, in real time.

3.3. POWER OUTPUTS

The equipment has three output and phase channels. In each one of them can be selected the desired output level as well as the phase angle.

This section is situated in the central section of the unit, and is clearly identified. All the controls, indicators, etc. contained in this part of the unit will be explained.

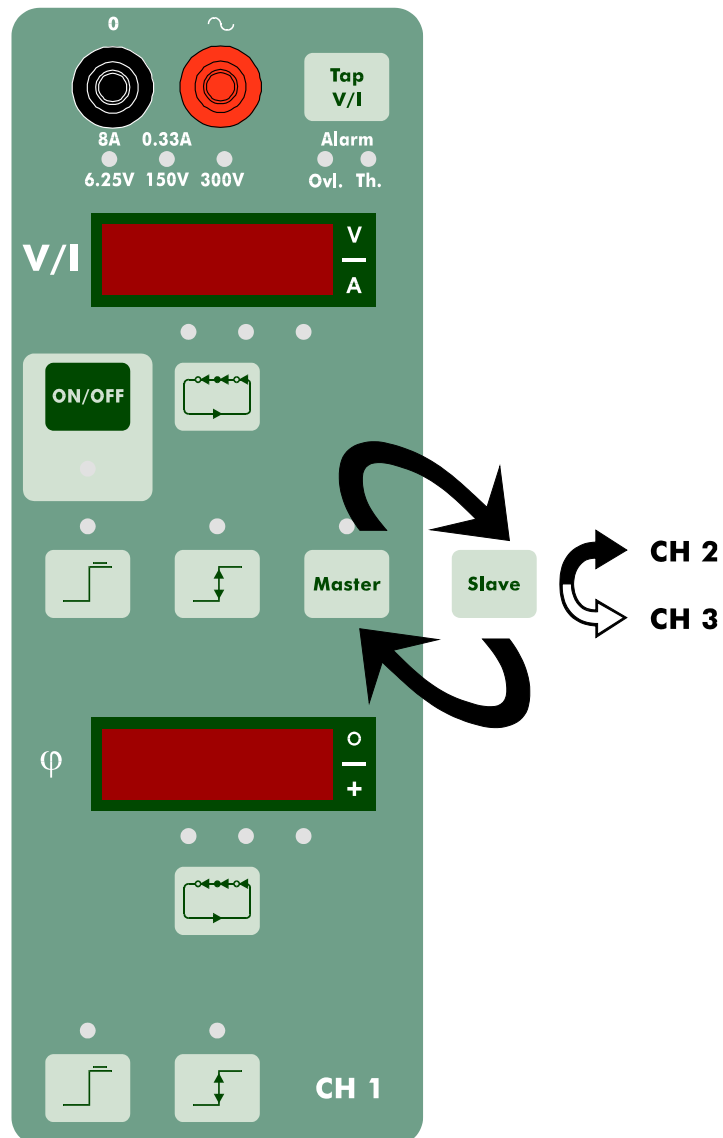

Figure 7: Power Output

3.3.1. LEVEL SECTION

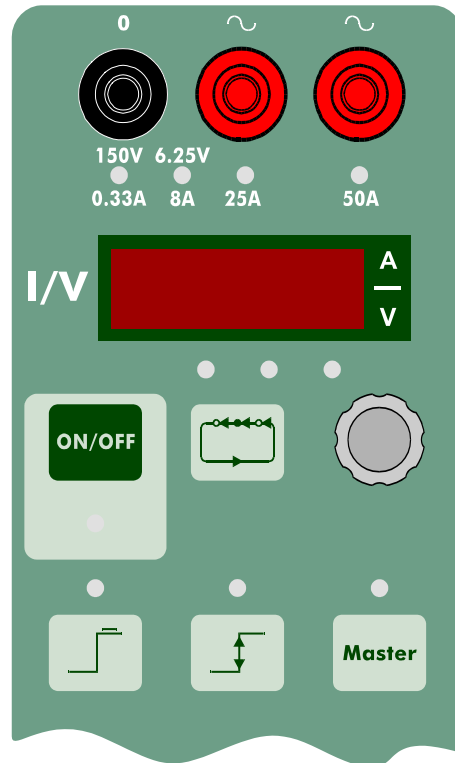
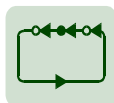

Figure 8: Level Selection

3.3.1.1. CONTROL KNOBS AND PRESS KEYS

a) Selecting the digit to be used



This key works in a sequential way and it is associated with 3 LEDs located above this press key. This allows the operator to select the output in a fine or course regulation, by changing the digit to be adjusted.

The following resolutions can be obtained:

- 1 digit.
- 10 digits.
- 100 digits.

When pressing this key for more than 2 seconds, it will block the rotating pulse generator, not allowing any modifications to the level selected.

b) Rotating control knob



This is a rotating pulse generator and has step by step sensation. The values can be increased or decreased by turning this control knob clockwise or anti-clockwise by one digit per step, according to the selected digit weight as described previously.

This knob has no end and can be controlled at any speed. However if the control knob is turned very fast the value will change at a maximum rate of 1 digit per second.

c) Output ON/OFF selection



When this key is pressed the output will turn on and the LED situated below will light up.

When it is pressed again it will disconnect this output and the LED will be off.

d) 2nd value selection

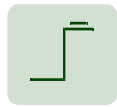

When this key is pressed it allows the selection of a 2nd value and it is shown in the display. This selection does not cancel the value already selected in the output at the moment. To distinguish the actual value from the 2nd value selected, the LED over the key lit when the 2nd value is displayed.

e) Activating 2nd value

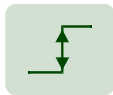

This key works in a sequential way. When pressed the output value changes to the 2nd value, when it is pressed again it will return to the 1st value.

When this key and the similar key in the phase section are pressed at the same time for more than 2 seconds this function if both sections becomes synchronized. To cancel you must repeat this process.

f) MASTER/SLAVE: regulation modes

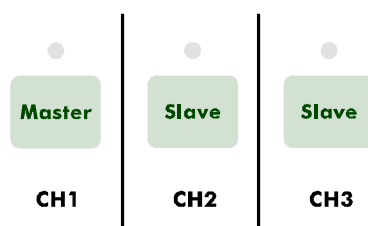

The following press keys are installed on the PTE-300-V to achieve regulation capability in terms of three-phase regulation, fault combinations, like a phase to phase, three-phase, etc.

- Output channel 1 (CH1): MASTER key.
- Output channel 2 (CH2): SLAVE key.
- Output channel 3 (CH3): SLAVE key.

When no key is activated, the output channels are completely independent in all their functions.

When the MASTER key of CH1 is activated, at least one slave must be activated also. The MASTER function affects all channels in SLAVE mode (CH1, CH2 or both) as follows:

- Any output value change made in CH1, through the rotating knob in level or phase angle, occurs immediately in the SLAVE channels.
- If the output mode (voltage or current) is changed in CH1, it changes immediately in the SLAVE channels.

- If the output range is changed in CH1, it changes immediately in the SLAVE channels.
- Any action made in the output control ON/OFF in CH1 occurs immediately in the SLAVE channels.
- Any action made in the *Step to 2nd Value* control in CH1 happens immediately in the SLAVE channel.
- The only operation made in CH1 that is not immediately reflected in the SLAVE channels is the *2nd Value Selection* that must be activated channel by channel in any case.
- The SLAVE channels remain independent in terms of control. It means that any action made in a SLAVE channel only affects itself.

3.3.1.2. OPTICAL INDICATORS AND DISPLAYS

a) LED indicator for 2nd value selection

- This is a 3 mm, red LED that is situated over the corresponding key. When this LED is lit, it indicates that it is in the *2nd Value Selection* mode and that this value is shown in the display.
- 

b) LED indicator when 2nd value is activated

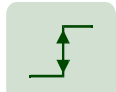
- This is a 3 mm, red LED that is situated over its corresponding press key. It has two states:
 - Not lit: indicates that the value in the output is the first value.
 - Lit: indicates that the value has changed to the second value.
- 

c) Output range and output type selection

-  This key has two function modes:

1. Selection of the output type: this key serves to select the output type desired, that is voltage (V) or current (I). When turning on the unit it will be in current output. To change this output to voltage you must press this key for more than 2 seconds. To change this output back to current, repeat the process.
2. Output range selection: this key also serves to select the output range, in voltage and current. This key works in a sequential way: each time it is pressed it will change the output range. There are 2 ranges in voltage and 4 ranges in current. They are:
 - Voltage:
 - 0 - 6.25 V
 - 0 - 150 V

- Current:
0 - 0.33 A
0 - 8 A
0 - 25 A
0 - 50 A

This key is associated with the 4 red LEDs with the ranges marked and the display in this section.

d) ON/OFF LED indicator



This is a 3 mm, red LED that is situated below the corresponding press key. It has two states:

- Lit: indicates that there is no output (OFF).
- Not lit: indicates that the output is on (ON).
- Not lit: indicates that there is no output (OFF).

This indicator shows the OUTPUT ACTUAL STATE. It can be either internally controlled by the unit (for instance, *Overload Alarm*).

e) Digit selection indicator

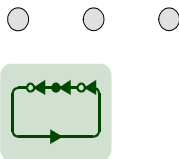

These three, 3 mm LEDs (red), indicate the digit selection for regulation. Only one will be lit, indicating the digit above it to be regulated.

f) Level selection display



The display is made up of 4 digits of 7 segments, red in color and 0.3 inches in height, which shows the selected values and the corresponding units to the selected parameter with three lightning indicators located to the right side of the display.

There are two different parameters available:

- Voltage (V).
- Current (A).

In current and voltage, depending on the selected range, the decimal point will adjust automatically. The V and A indicators will light up automatically when selected.

When the value in the display begins to flash, it indicates that the value selected and is not in the output.

g) Output range selection indicators

8A 0.33A

 6.25V 150V 300V

They are four red LEDs of 3 mm located below the output taps. These indicate the selected output range, in voltage or current.

These ranges are selected by pressing the *TAP I/V* key.

h) Alarm indicators

 **Ovl.** There are two, 3 mm LEDs (red) which indicate the status of the two alarms for the output of PTE-300-V. They are as follows:

Alarm

 **Th.**

1. Ovl: this LED indicates an overload in the output, whether it is current or voltage. When it is lit, the output will cut off and the display will begin to flash for 5 seconds. During this time it is possible to reset the output by pressing the ON/OFF button.
2. Th: this LED indicates an internal thermal overload, (temperature overload). When this alarm is on, the LED will light up, and the output will cut off. While this LED is on it is not possible to work with the unit and the operator must wait until the internal temperature lows.

NOTE: When the thermal alarm is lit, turn off the unit for at least 1/2 hour.

3.3.1.3. TAPS: Output taps

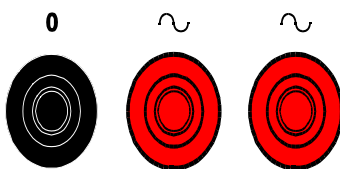

These taps are situated in the upper central part of the unit and consist of 3, 4 mm female connectors. With the unit two testing cables are supplied, which are used with these taps.

3.3.2. PHASE SECTION

This is situated to the right of the unit and is perfectly identified. It contains all the control knobs, keys, and LEDs necessary for the operator to use the functions in this section.

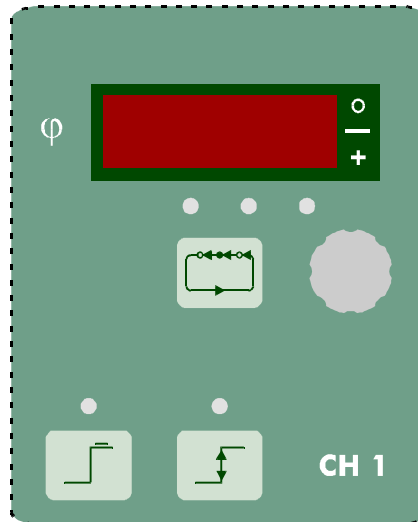
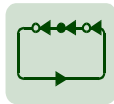

Figure 9: Phase Angle Selection

3.3.2.1. CONTROL KNOBS AND PRESS KEYS

a) Selecting the digit to be used



This key works in a sequential way and it is associated with 3 LEDs located above this press key. This allows the operator to select the output in a fine or course regulation, by changing the digit to be adjusted.

The following resolutions can be obtained:

- 1 digit.
- 10 digits.
- 100 digits.

When pressing this key for more than 2 seconds, it will block the rotating pulse generator, not allowing any modifications to the phase angle selected.

b) Rotating control knob

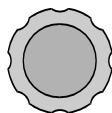

This is a rotating pulse generator and has step by step sensation. The values can be increased or decreased by turning this control knob clockwise or anti-clockwise by one digit per step, according to the selected digit weight as described previously. This knob has no end and can be controlled at any speed.

However if the control knob is turned very fast the value will change at a maximum rate of 1 digit per second.

c) 2nd value selection



When this key is pressed it allows the selection of a 2nd angle and it is shown in the display. This selection does not cancel the angle already selected in the output at the moment. To distinguish the actual value from the 2nd angle selected, the LED over the key lit when the 2nd angle is displayed.

d) Activating 2nd value



This key works in a sequential way. When pressed the phase angle in the output changes to the 2nd value, when it is pressed again it will return to the 1st value.

When this key and the similar key in the phase section are pressed at the same time for more than 2 seconds this function if both sections becomes synchronized. To cancel you must repeat this process.

3.3.2.2. OPTICAL INDICATORS AND DISPLAYS

a) LED indicator for 2nd value selection

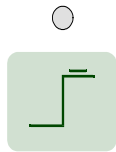

This is a 3 mm, red LED that is situated over the corresponding key. When this LED is lit, it indicates that it is in the 2nd Value Selection mode and that this value is shown in the display.

b) LED indicator when 2nd value is activated

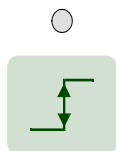

This is a 3 mm, red LED that is situated over its corresponding press key. It has two states:

- Not lit: indicates that the phase angle in the output is the first value.
- Lit: indicates that the value has changed to the second phase angle.

c) Digit selection indicator

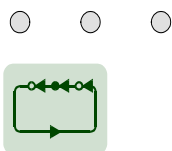

These three, 3 mm LEDs (red), indicate the digit selection for regulation. Only one will be lit and it indicates the digit above it to be regulated.

d) Phase selection displays



The display is made up of 4 digits of 7 segments, red in color and 0.3 inches in height, which shows the selected values.

3.4. GENERAL CONTROL SECTIONS

This part of the equipment refers to the general control. The unit contains several necessary controls to perform the following functions:

- Using RS-232.
- SYNCHRONIZE selection.
- EVENT Output.
- Monitor signals.
- BUS-PTE interconnection.

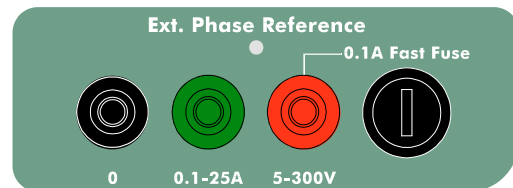
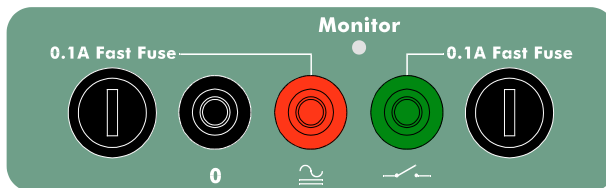
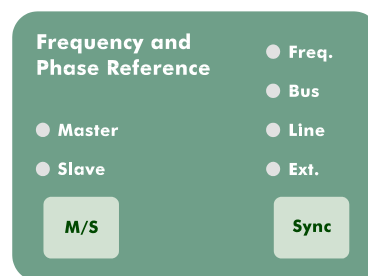
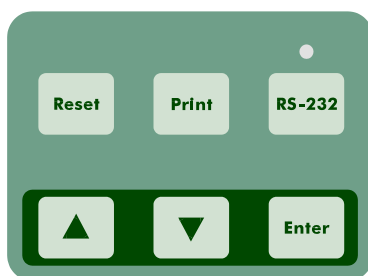
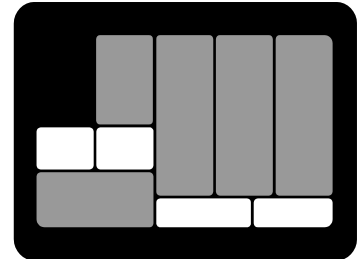

Figure 10: General Control Sections

3.4.1. CONTROL KEYS

3.4.1.1. Reset

Pressing this key a reset in the unit is made, selecting a three-phase voltage system synchronized to the frequency generated by the *IFG* (50 or 60 Hz).

3.4.1.2. Print

Pressing this key, if there is a serial input printer connected to the unit, the actual values on the displays will be printed.

3.4.1.3. RS-232 serial port control

RS-232

This press key controls the RS-232 COM port activation to communicate the unit to a PC. The LED above this key indicates this.

3.4.1.4. SYNCHRONIZATION

Sync

This key controls the different references available in the PTE-300-V. Each time this key is pressed a different reference is selected.

3.4.1.5. MASTER/SLAVE control

● **Master**

Through this press key it is possible to select the available control modes when PTE-300-V is interconnected with another PTE unit (BUS PTE).

● **Slave**

M/S

There are two function modes:

- Pressing normal: each time this key is pressed the mode will change to one of the following:
 - **Independent..**
 - **MASTER of reference:** PTE-300-V becomes the synchronizing reference for the connected equipment. The phase angles we select in that equipment will be referred to the 0° phase angle in PTE-300-V.
 - **SLAVE of reference:** the connected equipment becomes the synchronizing reference for PTE-300-V. The phase angles we select PTE-300-V will be referred to the 0° phase angle in the connected equipment.
- Pressing long: pressing for more than 2 seconds, the MASTER of control mode is selected. This allows the control of the outputs ON/OFF and *Step to 2nd Value* for all the channels, voltage and current, when interconnected with a PTE-50-CET.

3.4.2. OPTIC INDICATORS

3.4.2.1. RS-232 port indicator



RS-232

This is a 3 mm LED (red). When it lit, indicates that the serial port RS-232 is active so it can send or receive information.

3.4.2.2. SYNCHRONIZING REFERENCE indicators

They are three, 3 mm red LEDs. Only one is on at the same time.

- **Freq:** the internal generator generates the reference.

- Line** • **Line:** the reference is the main voltage supply.
- Bus** • **Bus:** the reference is another PTE unit connected via BUS-PTE. Normally the PTE-300-V or PTE-100-V. If the led is flashing there is no reference in the BUS.
- Ext.** • **Ext:** the selected reference is taken from another instrument or equipment connected in the external reference tap. If the led is flashing there is no valid reference.

3.4.2.3. Monitor state indicator

This is a 3 mm red LED, located above the *Monitor* taps. When it is on, indicates that the *Monitor* is ACTIVATED. When it is off, indicates the *Monitor* is DEACTIVATED.

3.4.3. CONNECTORS AND FUSES

3.4.3.1. Monitor input taps

These taps are located in the lower right hand part of the unit and consist of three, 4 mm female connectors. These taps receive the input signals to the unit.

- Black tap (0): this is the common tap
- Red tap: any DC or AC voltage between 5 and 250 V can be connected between the common tap (0) and this one. The presence of voltage will activate the *Monitor*.
- Green tap: between this tap and the common a DRY CONTACT can be connected. A close contact will activate the *Monitor*.

Both inputs are protected by fuses, fast characteristic, 0.1 A.

The *Monitor* signal fuses are situated to the left and to the right of the monitor taps. The fuse on the left protects the voltage-input tap and the fuse on the right protects the free contact input tap. To remove the fuse, turn the cap anti-clockwise. These are fast fuses, 5x20 mm, 0.1 A.

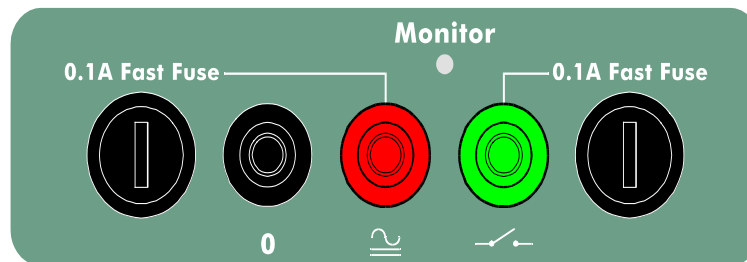
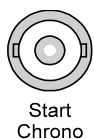

Figure 11: Signal Monitor

3.4.3.2. Auxiliary output to start an external timer



This is a BNC connector that delivers a “close contact” signal of 20 ms duration, with the main objective to start an external timer. This output will be active each time one of the following occurs:

- When the ON/OFF key of the unit is pressed, activating or deactivating the power output.
- When the *Step to 2nd Value* key is pressed, either in level or in phase.
- When performing a ramp, the frequency gets the selected value for *Start Chrono*.

3.4.3.3. RS-232 connector

This communication connector serial port RS-232 is a CANON connector of 9 pins, located in the upper left part of the unit. Its pin out is as follows:

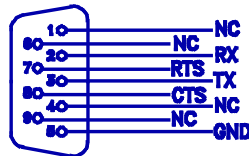

Where:

RS-232

NC	Not connected
GND	Earth ground
RX	Input DATA
TX	Transmission DATA
RTS	Output - Send
CTS	Input ready to receive

The unit is supplied with a connecting cable ready to connect directly to this output, to any type of computer or serial input printer.

4. FUNCTIONS: USE AND DESCRIPTIONS

Throughout this section a detailed description of the use and procedures for the PTE-300-V will be given. This unit has been designed to be used as a portable three-phase unit to test any kind of relays, as a stand-alone unit or interconnected to other auxiliary units. All the functions that are incorporated in this unit were designed to easily test the relays. This is achieved, as all functions are located on the front panel in a manual mode, which before required test units, which were programmable by an external computer.

Furthermore, the PTE-300-V, and thanks to the BUS-PTE, can be easily interconnected to other units in the PTE range, making the specific functions for relay testing, much more simple and effective.

4.1. FREQUENCY SECTION

This section describes the functions of the internal frequency generator incorporated in the PTE-300-V. It is obvious that this is combined with the power output to be effective. Furthermore, when used in ΔF (slip frequency) mode, the external reference input must be used.

4.1.1. INITIAL STATUS

When the unit is turned on the frequency generator has the following values and readings:

1. Initial frequency: this is 50.00 or 60.00 Hz. It depends on the frequency ordered when the unit was purchased.
2. Function mode: enters in the *Normal Frequency (F)*.
3. Reference of the unit: it will synchronize the voltage output to the internal frequency generator (Freq).

In summary, if a voltage or current value is selected, this will be in the output with the frequency at 50 or 60 Hz, as the frequency display indicates. If you turn the rotating knob, this frequency value will change, and the output frequency is instantaneously actualized to the actual display value.

4.1.2. FUNCTION MODE SELECTION

The Internal Frequency Generator (I.F.G.) has two function modes: *Normal Frequency* and *Differential Frequency*. To select one or another, use the press key MODE, which will indicate the state by the LED indicators located below F or ΔF . The following explains these frequency modes.

4.1.2.1. NORMAL FREQUENCY MODE (F)

In this mode the I.F.G. acts as an absolute frequency generator, that is, the values indicated in the display are the actual frequency output in Hz. The active range is 40 to 300 Hz.

- When we select a new value, the frequency is instantaneously actualized.
- It is capable to be programmed with different parameters in a way that it can automatically perform different frequency ramps or steps.

4.1.2.2. SLIP FREQUENCY MODE (ΔF)

In this mode the I.F.G. acts as a differential frequency generator. The output frequency will be the one that is applied to the external reference input plus/minus the difference selected in the frequency display. The output frequency is "SLIP" against the reference frequency. This mode cannot be used without an external reference. It allows selecting differences between ± 0.001 Hz up to ± 10.00 Hz.

4.1.3. DYNAMIC TEST: SELECTING FREQUENCY RAMPS

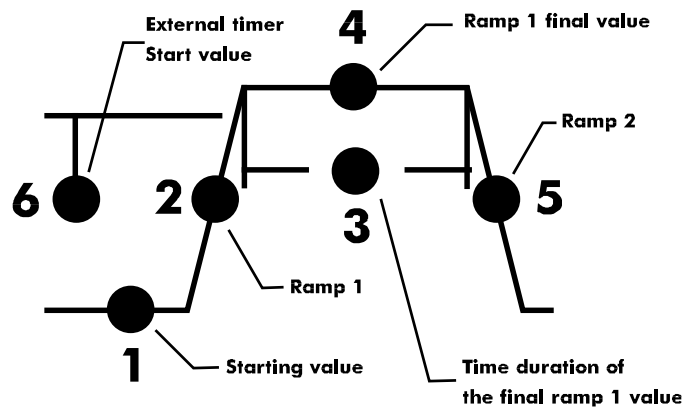

Figure 12: Frequency Ramp Selection

IMPORTANT: When the unit is generating a frequency and the operator wishes to select a ramp, this frequency WILL NOT CHANGE during the selection process, although it is not indicated in the display.

The process to select a frequency ramp is as follows:

1. Select *Normal Frequency* mode (F), if it is not in this mode before. Press the key *Set*, the LED indicator 1 (initial value of 1st ramp) will light up. Select in the display the frequency value desired as the ramp initial value. This selection can be made between 40 and 300 Hz.
2. Press the key *Set*, the LED indicator 2, (slope 1), will light up and the display will change to the units Hz/s. Selection is made by the rotating knob and the slope of the 1st ramp can be set in Hz per second. This selection is from 0.01 Hz up to 10 Hz/s. If 0 is selected the slope will be infinite, which means there is no ramp and the change is instantaneous to the second value, when ordered.
3. Press the key *Set*, the LED indicator 3, (time duration of the final value of the 1st ramp), will light up and the display change its units seconds (s). The rotating knob makes selection and it is the time, in seconds, in which remains the final value of the 1st ramp and it is the time before the second ramp begins. This selection is from 0.001 s up to 10 s. If 0 is selected, the final value remains until a manual order is given.
4. Press the key *Set*, the LED indicator 4, (final value of the first ramp), will light up and the display will change to the units Hz. Selection is made by the rotating knob and is in Hz, and the value selected is the final value of the 1st ramp. This selection is from 40 Hz up to 300 Hz.

5. Press the key *Set*, the LED indicator 5, (2nd ramp), will light up and the display will change the units to Hz/s. Selection is made by the rotating knob and it defines the slope of the 2nd ramp. This selection is from 0.01 Hz/s up to 10 Hz/s. If 0 is selected indicates that there is no slope and the change produced is instantaneous, when ordered.
6. In case of the 2nd ramp, the initial value is the same as the final of the first ramp, and the final value will be the initial value of the 1st ramp.
7. Press the key *Set*, the LED indicator 6, (value to start the timer), will light up and the display will change its units to Hz. Selection is made by the rotating knob, and the value is in Hz. When the ramp passes for this value will send a signal pulse to *Start Chrono*. The values selected can be from 40 to 300 Hz.
8. Press the key *Set*, the LED indicator 1 (initial value to start the ramp) will light up and the display will show the frequency value previously selected.

The ramp is now defined and ready to start. If the operator wishes to change any parameters or simply revise the settings made, the cycle may be repeated always stopping at the LED indicator 1. If any other of the LEDs is lit or it is in any other position, the ramp will not start.

4.1.4. DYNAMIC TEST: SELECTED RAMP START

To start the selected ramp, the *Ramp* key should be pressed once and the ramp will follow the procedure previously programmed. The LED indicators will begin to flash slowly indicating where the ramp is at each stage.

Concerning the LED indicator 6 (start value of the timer), when the frequency value reaches the selected value, this LED will light up for only 1 second, indicating that the signal has been sent to start the timer.

4.1.5. DYNAMIC TEST: STEP TO 2ND VALUE

When only a step to a second value is desired without a ramp, a second value step can be achieved by pressing *Ramp* key for 2 seconds. Repeating this process the step can be made to the first value.

4.1.6. TTL AUXILIARY OUTPUT: CHARACTERISTICS AND APPLICATIONS

The auxiliary output *Freq. Out* generates a square wave output signal TTL (5 V) that corresponds to the frequency and phase value, of the voltage output (whether it is synchronized to Line, Freq, Ext or Bus). This output allows to use the PTE-300-V as a highly accurate frequency reference for other units (such as our COMPATEST 1000) and to synchronize the PTE-300-V outputs to any other instrument like an oscilloscope, for example.

4.2. LEVEL SECTION: OUTPUT POWER

This section describes the correct use of the PTE-300-V power outputs. The output can be selected in voltage up to 300 V or in current up to 8 A. The power outputs can be synchronized to four available references as it is explained in this section, as well. Because the three output channels are similar, only one will be explained.

4.2.1. INITIAL STATUS

When the unit is turned on, the following values and selections are made:

1. Output mode: voltage.
2. Selected range: 300 V.
3. Selected value: 00.00 V.
4. Output status: OFF.
5. Reference: Freq.

4.2.2. OUTPUT MODE SELECTION (V/I)

As mentioned before, the PTE-300-V can be used as a voltage or current source. When the unit is turned on it will be in the current mode. The voltage output is achieved in the following way: press the *TAP V/I* key for more than 2 seconds. The display will change its units to A (Amps) and the output range will automatically change to 0.33 A (150 V). The values selected from now on will be in amps.

To return to the voltage mode press the same key again for more than 2 seconds.

4.2.3. OUTPUT RANGE SELECTION

The following output ranges are available:

- Voltage mode: 6.25 / 150 / 300 V.
- Current mode: 0.33 / 8 A.

To select any of these ranges press the *TAP V/I* key. The display will automatically change. In case we have selected a value and this is greater than the new selected range, the value will set to the maximum value in the selected range.

The active range is that which has its corresponding LED lit.

4.2.4. REFERENCE SOURCE SELECTION

When the unit is turned on, it is synchronized to its own internal signal produced by the *IFG*. This is indicated with the *FREQ* LED on. If you want to change this reference you must do the following:

1. Press the *SYNC* key. The unit will pass to the reference *BUS-PTE*, which is indicated by the corresponding LED marked *BUS*. This implies that the reference is the *BUS-PTE*, with any other unit of the *PTE* range. If the units are not interconnected (*BUS-PTE* is not connected or there is no *Reference Master* selected) the LED indicator will flash slowly indicating that there is no reference. If there is no reference in the *BUS* and the output is turned on, the unit will synchronize automatically to the last valid reference (*FREQ*).
2. Press again the *SYNC* key. The unit will pass to the *LINE* reference, which is indicated by the corresponding LED marked *LINE*. This implies that the reference is the main voltage supply.
3. Press again the *SYNC* key. The unit will pass to *External Reference*, which is indicated by the corresponding LED marked *EXT*. This implies that the reference is now the signal connected to the *External Phase Reference Input*, introduced in the taps *Ext. Phase Reference*. If there is no

signal in these taps the LED EXT will flash slowly indicating that there is no reference or that it is not suitable.

If there is no reference and the output is turned ON, it will synchronize to the last valid reference. The same occurs if there is a valid external reference and it disappears.

4. Press again the SYNC key. The unit will pass to the FREQ reference, which is indicated by the corresponding LED marked FREQ. This implies that the reference is, once again, the frequency signal produced by the IFG.

These changes can be made while the output is ON.

4.2.5. OUTPUT VALUES SELECTION

This is achieved by turning the rotating knob and the digit selector key. The actual value selected is shown on the display, whether the output is ON or OFF. The selected value shown in the display remains the same when the output is ON. If the value selected is higher than allowed in the range chosen, the rotating knobs continues turning, but the value cannot be increased.

The unit **does not feedback values less than 3 % of the end of the selected range**. In this case the phase and the magnitude values cannot be guaranteed. The following table clarifies this:

Selected range	3% of range not feedback	Feedback
300 V	0 - 9 V	9 - 300 V
150 V	0 - 4.5 V	4.5 - 150 V
6.25 V	0 - 0.187 V	0.187 - 6.25 V
0.33 A	0 - 0.01 A	0.01 - 0.33 A
8 A	0 - 0.24 A	0.24 - 8 A

In this case, if you increase the level with the output ON, overload alarms may be produced, due to transitories, disconnecting the corresponding channel.

4.2.6. OUTPUT CONTROL: ON/OFF AND ALARMS

The power output status is controlled by the ON/OFF key, and is active when the corresponding LED is lit. To turn off this output simply press the key again.

This output is protected by 2 types of electronic protection, which are indicated by the corresponding LEDs marked, OVERLOAD (OVL) and/or THERMAL (TH).



When either of these are active (lit), the power output is immediately turned off and the LED ON/OFF will turn off.

When the overload alarm is lit, it is due to an overload of the maximum power values allowed in the output. In some cases it may be due to fast transitories that the unit cannot feedback properly, such as a sudden step from a very low output value to another one very high. To start again, simply press the output key ON to activate the output. If the cause of this overload has been rectified the unit will function as normal, if the overload remains the unit will turn off again.

When the thermal alarm is lit, it is because the internal temperature has reached the allowable limit. When this occurs, you must turn off the unit. When this alarm LED is lit, the unit cannot be used, and there will be no output. When the unit has cooled down to a lower temperature the LED will go off and the unit can be used.

4.2.7. DYNAMIC TESTS: STEP TO 2ND VALUE

The PTE-300-V allows the operator to make dynamic tests, by allowing jumps (steps) from one value to another, whether it is from higher to lower or vice versa. This is very useful, for example, when performing dynamic characteristic tests. This is achieved as follows:

1. Press the key . In the display will appear the reading "0000" or the 2nd value previously recorded. Select with the rotating knob the desired value to acts as 2nd value.
2. Press again the key . The display will show the actual value that is the 1st value. Turn on the output if this is off.
3. Press the key . This will produce instantaneously the step from the actual value to the 2nd selected value. At the same time there is a signal sent to *Start Chrono* output, to start an external timer if desired. Furthermore, the LED located above this press key indicates that the 2nd value is in the output. **IMPORTANT: When the unit is in this situation the displayed value cannot be changed even if the rotating knobs are turned.**

When this key  is pressed again, the step will be the opposite, which is from the 2nd value to the 1st one. At the same time, there is a signal sent to *Start Chrono* output. The LED will go off indicating the output is at the 1st value.

NOTA: You can select a 2nd value even when the corresponding output is on. In this situation, though the display is not showing the actual output value, this remains in the output.

4.3. PHASE ANGLE SELECTION

This section describes in detail the use of the phase shifter incorporated in the PTE-300-V, as well as the *External Phase and Frequency Reference*.

The display in this section is indicated in degrees (0-359.9) between the output and the reference choose (Freq. Ext., Line, Bus) in a ANTI-CLOCKWISE sense as follows

4.3.1. PHASE ANGLE SENSE

PTE-300-V allows two phase angle senses: AMERICAN or EUROPEAN (ordered by the client). Whatever it is selected, the initial unit status will be a balanced three phase system, turning ANTI-CLOCKWISE.

a) EUROPEAN SENSE:

The display shows, in sexagesimal degrees (0-359.9), the phase angle between the OUTPUT and the selected reference source (Freq., EXT, LINE and BUS), considered positive when this is ANTI-CLOCKWISE, that is:

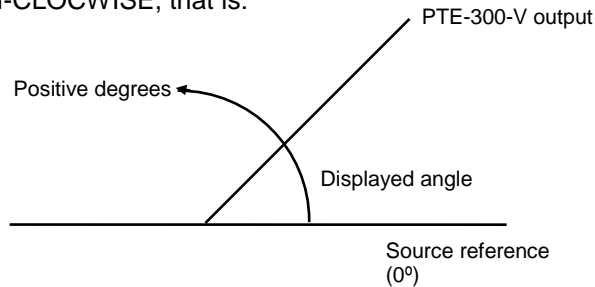

Figure 13: *Phase Angle Selection (European)*

When the unit is turned on, the phase angle selection sets the following default states and values:

1. Selected value in channel 1 (CH1): 000.0°
2. Selected value in channel 2 (CH2): 240.0°
3. Selected value in channel 3 (CH3): 120.0°

b) AMERICAN SENSE:

The display shows, in sexagesimal degrees (0-359.9), the phase angle between the OUTPUT and the selected reference source (Freq., EXT, LINE and BUS), considered positive when this is CLOCKWISE, that is:

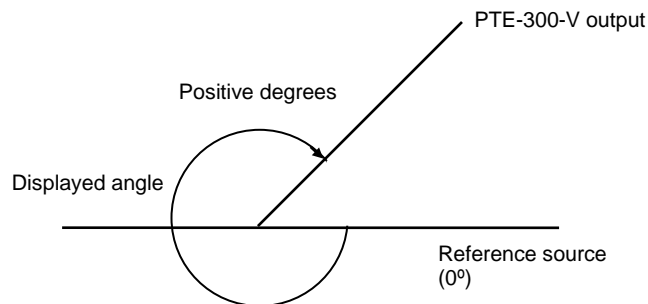





Figure 14: *Phase Angle Selection (American)*

When the unit is turned on, the phase angle selection sets the following default states and values:

1. Selected value in channel 1 (CH1): 000.0°
2. Selected value in channel 2 (CH2): 120.0°
3. Selected value in channel 3 (CH3): 240.0°

4.3.2. DYNAMIC TESTS: STEP TO 2ND VALUE

The PTE-300-V allows the operator to make dynamic tests, by allowing jumps (steps) from one value to another, whether it is from higher to lower or vice versa. This is very useful, for example, when testing out-of-step generator protective relays. This is achieved as follows:

1. Press the key . In the display will appear the reading "0000" or the 2nd value previously recorded. Select with the rotating knob the desired value to acts as 2nd value.
2. Press again the key . The display will show the actual value that is the 1st value. Turn on the output if this is off.
3. Press the key . This will produce instantaneously the step from the actual value to the 2nd selected value. At the same time there is a signal sent to *Start Chrono* output, to start an external timer if desired. Furthermore, the LED located above this press key indicates that the 2nd value is in the output. **IMPORTANT: When the unit is in this situation the displayed phase angle cannot be changed even if the rotating knobs are turned.**

When this key  is pressed again, the step will be the opposite, which is from the 2nd value to the 1st one. At the same time, there is a signal sent to *Start Chrono* output. The LED will go off indicating the output is at the 1st value.

NOTA: You can select a 2nd value even when the corresponding output is on. In this situation, though the display is not showing the actual output value, this remains in the output.

4.3.3. USE OF EXTERNAL REFERENCE INPUT

The *External Reference* input admits two types of signal with frequencies between 40 and 70 Hz: current (from 0.1 A up to 25 A) or voltage (from 5 V up to 300 V). This input is very useful as it allows the unit to work in a differential mode respect to the signal inputs. Because of the wide range of input values in both voltage and current, it is capable to work with various types of supply generators for a signal reference.

The current input should be connected to the black tap marked "0" and the green tap marked 0.1 - 25 A. The voltage input should be connected to the black tap marked "0" and the red tap marked 5 - 300 V.

IMPORTANT NOTE: The current input has low impedance SHUNT detector. NEVER connect a voltage signal to this tap, as it is equivalent to short-circuit. It may cause serious damage to the external voltage supply if it is not protected.

When *External Reference* is selected as reference source in the unit (Ext.), if it is valid, the LED located to the left hand of (0) tap will light up.

In case this reference signal is not proper, the unit will be synchronized to the last valid reference.

4.4. GENERAL CONTROL SECTION

The general control section is intended to acts as an interface between the unit and other PTE units, extern printer, computer, and detects the answer from the under testing relay through *the Signal Monitor*. All these functions are described below.

4.4.1. SIGNAL MONITOR

It is designed to receive the signals from the relay being tested and the status is shown in the LED indicator marked "MONITOR".

The *Signal Monitor* is activated (LED monitor lights up) in one of the following conditions:

1. When there is a voltage between the common tap (black) and the voltage tap (red). This voltage can be between 5 to 250 V, ac or dc. This input tap is protected with a fuse clearly marked on the front panel.
2. When there is a closed, voltage free, contact between the common tap (black) and the contact tap (green). This input tap is protected with a fuse clearly marked on the front panel.

NOTE: Be sure that, when connecting a signal to the green tap, it is voltage free. If not, the protection fuse will break immediately.

4.4.2. USE OF THE MASTER/SLAVE PRESS KEY

The press key *MASTER/SLAVE* is used to select the status of the unit, in terms of REFERENCE and/or CONTROL when it is connected with another equipment of the same model or other models in the PTE range. In the PTE-300-V, three working modes can be selected. They are:

- a) **Independent:** this is the normal mode used when the unit is working independently by itself. None of the LEDs will be lit. When turning ON the unit it will be in independent mode.
- b) **MASTER/SLAVE of control:** this is exactly what the names imply; the unit will either be working as the *Master* or as the *Slave*, with regards to the command controls. In case that a unit is the MASTER means that all the values selected in frequency, voltage, or phase will be set automatically, and at the same time, in the units which are in SLAVE mode. When a unit is in the SLAVE mode the controls can be used as normal and, furthermore, when there is a change in the MASTER this change is produced in the SLAVE unit from the value that is already selected in the SLAVE.

The selection of these modes is as follows:

1. Press the key *MASTER/SLAVE*, the LED indicator to the left (M) will light up, indicating the unit is now selected as the **Master of Controls** in the system.
2. By pressing this key again the unit will change to be in the **Slave of Controls** mode and the corresponding LED marked (S) will light up.

3. When pressing this key again the unit will return to the independent mode and none of the LEDs will be lit.

- c) **MASTER/SLAVE of references:** As the name implies the unit will act as a MASTER or SLAVE of reference.

When a unit is a MASTER the selected reference in the MASTER unit (Freq., EXT, LINE, BUS) acts as the reference to all the units connected to the BUS-PTE, if the other units are in the SLAVE mode.

When a unit is in the SLAVE REFERENCE mode, the reference will come from the unit that is in the MASTER REFERENCE mode. The reference source, in the SLAVES units, is automatically selected to the BUS.

The selection of these modes is as follows:

1. Press the key *MASTER/SLAVE* for more than 2 seconds, the LED indicator on the right marked (M) will light up for 1 second, after the LED indicator on the left marked (S) will light up for 1 second, and then both LEDs will be off.
2. If the key remains pressed, the selection cycle starts again. To select one of the three modes, just release the key when the desired is selected.

The sequence allows the following modes:

- (M) LED indicator lit: The unit is the MASTER OF REFERENCES.
- (S) LED indicator lit: The unit is in SLAVE OF REFERENCE mode.
- NO LEDs are lit: The unit is in INDEPENDENT Mode .

4.5. COMMUNICATION IN BUS-PTE

4.5.1. EVENTS IN BUS-PTE

The PTE range equipment has been designed in such a way that the test equipments can be interconnected via the BUS-PTE connector, thus forming a stronger system when testing. The equipment not only can receive commands by software, but can also send information about its own status through determined signals, called EVENTS. Activation and deactivation of the *Signal Monitor*, *Output On* or *Off*, a *Step to 2nd Value* in amplitude and/or Phase, etc. are some examples of these mentioned EVENTS:

a) Positive events:

- Monitor active in a PTE equipment.
- Output active in a PTE equipment.
- An output value step to a second level, higher in value that the first one.
- Phase angle step to a second level, higher in value that the first one.

b) Negative events:

- Monitor becomes non-active in a PTE equipment.
- Equipment output is cut off.
- An output value step to a second level, lower in value than the first one.
- Phase angle step to a second level, lower in value than the first one.

In any case, the documentation supplied with a PTE equipment, gives information about the particular events transmitted to the BUS-PTE by the particular unit.

4.5.2. EVENT TRANSMITTED BY A PTE-300-V

A PTE-300-V sends to the BUS-PTE the following events:

a) Positive events:

- Output ON.
- *Step to 2nd Value* (voltage/current), higher than the actual.
- *Step to 2nd Value* (phase angle), higher than the actual.
- *Signal Monitor active*.

b) Negative events:

- Output OFF.
- *Step to 2nd Value* (voltage/current), lower than the actual.
- *Step to 2nd Value* (phase angle), lower than the actual.
- *Signal Monitor active*

4.6. SPECIAL FUNCTIONS

4.6.1. AUTO OFF

In case this function is selected, the output channels ON will be automatically turned off when a STOP signal is received from a timer connected to the PTE BUS.

PTE-300-V has this function not selected by default. To activate or deactivate it, you must do the following:

1. Press for 2 s *Enter* key located between the *Print* and *RS-232* keys. The following readings will appear in the displays:

CH1	CH2	CH3
FUnC	Auto	oFF
diSA		

2. To activate or deactivate the function, press again the *Enter* key, emerging in the phase angle display of CH1: **EnAb** (enable) or **diSA** (disable).

3. Once the selection is made, press again the *Enter* key for 2 seconds to leave the selection.

4.6.2. FAILURES DETECTION

The PTE-300-V incorporates a self-check function that is active every time the unit is turned ON. If a failure is detected in one or more of the controlled parameters, a message appears in the displays in the following manner:

ABCD⇒ Level Display EFGH⇒ Phase Display								
	A	B	C	D	E	F	G	H
0	Always 0	No error	No error	No error	No error	No error	No error	No error
1		LINE failure	RadF temp.	---	+12VA high	+5V high	+12V high	+28V high
2		6'25 fuse	Int temp.	PIIClk failure	+12VA low	+5V low	+12V low	+28V low
3		1+2	1+2	---	+12VA null	+5V null	+12V null	+28V null
4		150 fuse	OVL	Trf temp.	-12VA high	No error	-12V high	-28V high
5		1+4	1+4	---	1+4	+5V high	1+4	1+4
6		2+4	2+4	2+4	2+4	+5V low	2+4	2+4
7		1+2+4	1+2+4	---	3+4	+5V null	3+4	3+4
8		300 fuse	OVL	RadA temp.	-12VA low	No error	-12V low	-28V low
9		1+8	1+8	---	1+8	+5V high	1+8	1+8
A		2+8	2+8	2+8	2+8	+5V low	2+8	2+8
B		1+2+8	1+2+8	---	3+8	+5V null	3+8	3+8
C		4+8	4+8	4+8	-12VA null	No error	-12V null	-28V null
D		1+4+8	1+4+8	---	1+C	+5V high	1+C	1+C
E		2+4+8	2+4+8	2+4+8	2+C	+5V low	2+C	2+C
F		1+2+4+8	1+2+4+8	---	3+C	+5V null	3+C	3+C

Notes:

---: This code will never be shown.

xxx: Basic error code.

1+2: This code must be interpreted as the occurrence of basic errors 1 and 2 simultaneously.

Furthermore, the output fuses status can be checked, identifying the faulty one, if exists, by the bits FUS.XXX. To perform this checking, proceed as follows: press, at the same time, during more than two seconds, the press keys *Step to 2nd Value* and *the Selection of the digit to be regulated*. If there is any fuse failure, the corresponding error message will appear in the displays. If not, nothing will appear, and the operator can follow with the normal operation.

Press both at the same time

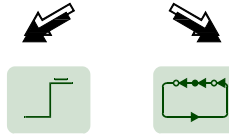

VERY IMPORTANT: Any load connected to the unit should be disconnected from the taps before using this function because it checks the three output ranges, generating voltages in the output to check the fuses.

Any errors in the bits previously mentioned are visualized in each channel with the following.

ABCD⇒ Level Display

EFGH⇒ Phase Display

As mention for the initial check of the power supplies. To remove this reading press the ON/OFF key one or two times, depending on the error detected.

5. SPECIFICATIONS

PTE-300-V contains the following outputs:

- Frequency generated between 40 and 300 Hz.
- Three power outputs up to 300 V in voltage mode and 8 A in current mode, with angle phase regulation between 0° and 360°.

5.1. FREQUENCY GENERATOR

- Indication of selected value: 4 digits display LED.
- Output range: 40.00 - 300.0 Hz.
- Regulation resolution selectable between:
 - 0.01 Hz
 - 0.1 Hz
 - 1 Hz
- Accuracy: ± 1 digit ± 0.003 Hz of the selected value
- **Dynamic frequency test:**

Available **through the front panel controls**. The following functions are available:

- Programming of a 1st ramp with a slope selectable between 0.01 Hz/s to 10 Hz/s.
 - Programming of the frequency value, to act as the limit of the above mentioned ramp, between 40 and 300 Hz.
 - Programming of the time duration that the above mentioned frequency value remains before beginning the 2nd frequency ramp, from 0.01 s to 10 s.
 - Programming of a 2nd ramp with a slope selectable between 0.01 Hz/s to 10 Hz/s.
 - Programming of a frequency value, on which the unit starts an external timer, between 40 and 300 Hz.
 - The frequency ramps are be stopped when the signal monitor is activated, and the actual value must be is indicated in the display.
 - Programming of a dynamic step from a selected value to another one previously selected.
- **Differential frequency mode:**

The frequency generator has a differential mode, which allows selecting a constant difference of frequency between an external reference and the power output of the unit. It has the following technical characteristics:

- Range: ± 9.999 Hz.
- Resolution:
 - 0.1 Hz
 - 0.01 Hz
 - 0.001 Hz
- Accuracy: ± 1 digit, ± 0.001 Hz of the selected value.
- External frequency reference range: 40 - 70 Hz.

5.2. POWER GENERATORS

- a) Three independent power outputs up to 300 V in voltage mode and 8 A in current mode, with angle phase regulation between 0° and 360°
- Amplitude indicator: 4 digits display LED.
 - Available ranges:
 - Voltage Mode: 0 - 6.250 V Regulation resolution: 0.001 / 0.01 / 0.1 V
0 - 150.0 V Regulation resolution: 0.1 / 1 / 10 V
0 - 300.0 V Regulation resolution: 0.1 / 1 / 10 V
 - Current Mode: 0 - 0.330 A Regulation resolution: 0.001 / 0.01 / 0.1 A
0 - 8.000 A Regulation resolution: 0.001 / 0.01 / 0.1 A
 - Accuracy: better than 1 % of the selected value between 10 % and 100 % of the selected range.
 - Power: 100 VA (1 minute) and 50 VA continuously.
 - Protection: overload and thermal.
 - Output mode: floating, completely isolated of the rest and the ground.
 - Output distortion:
 - Typical: < 0.5 %
 - Maximum: 1 %
 - Phase angle regulation: 0 - 359.9° .
 - Phase angle regulation resolution:
 - Selectable between: 0.1 / 1 / 10° .
 - Accuracy: $\pm 0.5^\circ$ of the selected value.
- b) The following functions are available for each channel, through front panel controls:
- Selection of 2nd value (fault value) while the actual value remains in the output.
 - Push-button to step to the above mentioned value.
 - This feature exists for amplitudes and phase angles, independent or linked.

- c) One of the output channels is available to be configured as *Master* of the other two, which can be configured as *Slave* or *Independent*. Every change made in the *Master* channel will be effective in the *Slave* channels, at all levels.

5.3. EXTERNAL REFERENCE INPUT

The unit has available an external reference input, capable to receive voltage or current signals from any external source in the following ranges:

- Voltage input: between 5 and 300 V.
- Current input: between 0.1 and 25 A.
- Frequency range: between 40 and 70 Hz.

5.4. SIGNAL MONITORS

The unit has a signal monitor that can work with dry contacts and live voltage signals from 5 to 250 V ac or dc.

5.5. AVAILABLE REFERENCES

The equipment power output has the possibility to be referenced to the following synchronizing sources:

- Internal Frequency Generator.
- Communication BUS.
- Voltage supply of the unit.
- External reference Input.

5.6. CONTAINER

The unit is contained in aluminum case that, when closed, offers an IP-65 protection.

6. TECHNICAL ASSISTANCE, AFTER SALES SERVICE AND WARRANTY

6.1. WARRANTY

Our warranty expresses the confidence we have in our products, based on the reliability and functions that are expected by our clients.

The warranty covers the repairs and/or replacements of components, which are faulty without costs.

The software designed by EUROSMC, either installed in the product or in the computer, is guaranteed of programming instruction failures.

Period: All products made by EUROSMC are guaranteed for a period of one year from the date and/or day reflected in the warranty, which is included with the unit.

EUROSMC will repair or replace any abnormal function or defects in our product that were not provoked by the following, which may cause the warranty to be revoked:

- Improper use of the product, incorrect connections or operations not specified or explained in this *Instruction Manual*.
- Any manipulation of the product, repairs, adjustments, or changes, made by unauthorized persons.
- The use of the product outside its specifications.

6.2. AFTER SALES SUPPORT

EUROSMC offers the supply of materials and components in all our products for 3 years after the product is no longer manufactured. We offer our technical support for a 5-year period.

6.3. OTHER EUROSMC PRODUCTS

For more information of our product range, please consult our local representative or us. Generally we manufacture the following:

- Relay testing equipment for voltage, current, frequency and synchronizing relays.
- Portable timers.
- Alternating current test equipment.
- Current supplies.
- Systems to test MCB's.
- Voltage and current regulation equipment.