

Technical Information

RTD TH13, TH14 and TH15

RTD assemblies in thermowells with spring loaded insert and enclosure for process industry



Application

The TH13, TH14 and TH15 temperature sensors are RTD assemblies installed in Thermowells and designed for use in all types of process industries, including harsh environments, due to their rugged design. The sensor is made up of a measurement probe with an insulated RTD element, sheath and a thermowell made of bar-stock material.

Among other applications the sensors can be used in process industries such as:

- Chemicals
- Petrochemical
- Power plants
- Refineries
- Offshore platforms

Head Transmitters

Instead of directly wiring your temperature sensors to your control system, use transmitters to reduce wiring and maintenance costs while increasing measurement accuracy.

Field Transmitters

Temperature field transmitters with HART® or FOUNDATION Fieldbus™ protocol for highest reliability in harsh industrial environments. Blue backlit display with large measured value, bargraph and fault condition indication for ease of reading.

Your benefits

- High flexibility due to modular assembly with standard terminal heads and customized immersion length
- One Source shopping for temperature measurement solutions. World class transmitter with integrated sensor offering for heavy process industry applications.
 - Remove and Install straight out of the box!
- Improved Galvanic Isolation on most devices (2 kV)
- Simplified Model Structure: Competitively priced, offers great value. Easy to order and reorder. A single model number includes sensor and transmitter assembly for a complete point solution
- All iTEMP transmitters provide long term stability ≤ 0.05 % per year
- Fast response time with reduced/tapered tip form

Function and system design

Measuring principle

These resistance thermometers use a Pt100 temperature sensor according to IEC 60751. This temperature sensor is a temperature-sensitive platinum resistor with a resistance of 100 Ω at 0 °C (32 °F) and a temperature coefficient is $\alpha = 0.003851 \text{ } ^\circ\text{C}^{-1}$.

There are generally two different kinds of platinum resistance thermometers:

- **Wire wound (WW):** Here, a double coil of fine, high-purity platinum wire is located in a ceramic support. This is then sealed top and bottom with a ceramic protective layer. Such resistance thermometers not only facilitate very reproducible measurements but also offer good long-term stability of the resistance/temperature characteristic within temperature ranges up to 600 °C (1 112 °F). This type of sensor is relatively large in size and it is comparatively sensitive to vibrations.
- **Thin film platinum resistance thermometers (TF):** A very thin, ultrapure platinum layer, approx. 1 μm thick, is vaporized in a vacuum on a ceramic substrate and then structured photolithographically. The platinum conductor paths formed in this way create the measuring resistance. Additional covering and passivation layers are applied and reliably protect the thin platinum layer from contamination and oxidation even at high temperatures.

The primary advantages of thin-film temperature sensors over wire wound versions are their smaller sizes and better vibration resistance. A relatively low principle-based deviation of the resistance/temperature characteristic from the standard characteristic of IEC 60751 can frequently be observed among TF sensors at high temperatures. As a result, the tight limit values of tolerance category A as per IEC 60751 can only be observed with TF sensors at temperatures up to approx. 300 °C (572 °F). For this reason, thin-film sensors are generally only used for temperature measurements in ranges below 400 °C (932 °F).

Measuring system

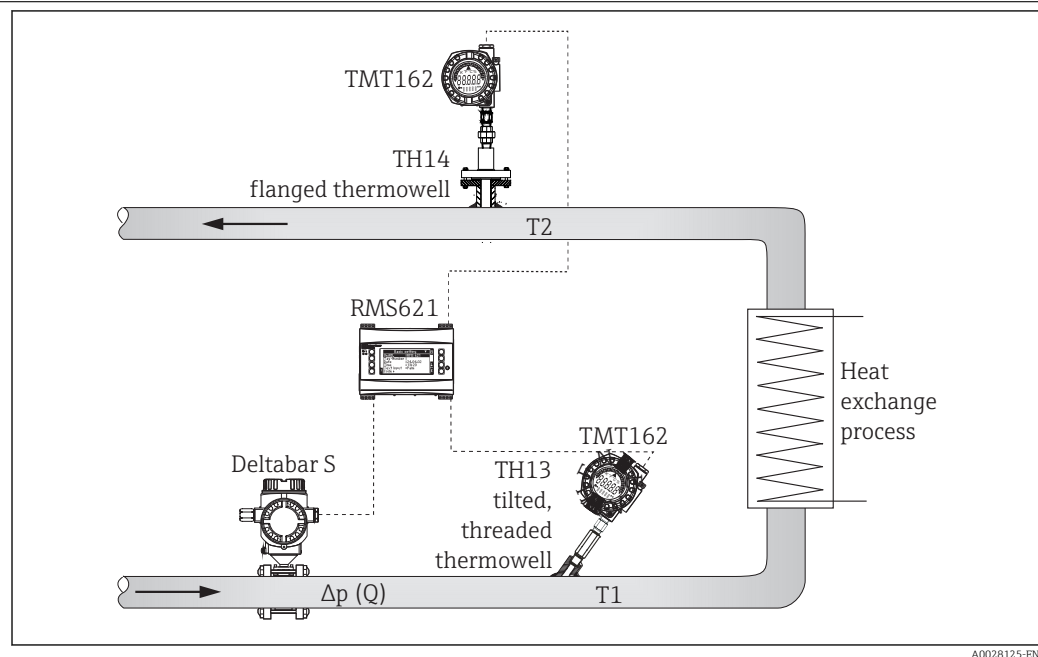

1 Example of an application of the temperature assemblies

Water - heat Differential

Calculation of heat quantity which is emitted or absorbed by a water flow in a heating or cooling system. The quantity of heat is calculated from the process variable for Δp flow (Q) and the differential from the feed and return temperature ($T_2 - T_1$). Bidirectional energy calculations, such as the calculating systems with changing flow direction (charging/discharging the heat accumulator) are also possible.

Energy manager RMS621

Energy conservation and cost expenditures are significant issues in today's industry. Accurate flow monitoring and calculation is the basis for thorough analysis and billing of energy. This data can serve as a basis to maximize savings potential and help in controlling operational costs on a daily basis. Endress+Hauser's energy managers provide accurate and reliable calculations for the

monitoring and control of energy consumption (both produced and consumed) according to international standards, e.g. IAPWS-IF 97, AGA8, ISO 5167 etc. For RMS621 details see Technical Information.

iTEMP TMT162 Temperature Field Transmitter

Aluminum or stainless steel dual compartment explosion - proof enclosure and compact, fully potted electronics provide the ultimate protection in harshest environments. TMT162 prevents costly plant shutdowns by detecting corrosion on RTDs or thermocouples before it corrupts the measured value. Endress+Hauser's Field Temperature Transmitters with backlit display and sensor backup functionality are designed with safety in mind to keep your plant, equipment and personnel safe. For TMT162 details see Technical Information.

Deltabar S/Cerabar S

The evolution series of Cerabar S/Deltabar S represents a decisive step ahead in making pressure instrumentation better and safer for the process industry. The development of new products thrives especially on the knowledge, commitment and experience of staff members. Permanent high performance can only be achieved if dedicated and enthusiastic people provide their ideas. Endress +Hauser's instruments are not only supposed to distinguish themselves for customers and users by technological novelties but also by the presence of people supporting this progress, be it in service, sales or production. For Deltabar S & Cerabar S details see Technical Information.

Equipment architecture

The single and duplex element RTDs are designed to measure temperature in a variety of process and laboratory applications. These RTDs are specifically designed for use in two different process temperature ranges and they will provide accurate and repeatable temperature measurement through a broad range of -200 to 600 °C (-328 to 1 112 °F). Low range thin film RTDs -50 to 200 °C (-58 to 392 °F) are constructed using silver plated copper internal leads, PTFE wire insulations with potting compounds to resist moisture penetration. High range RTDs -200 to 600 °C (-328 to 1 112 °F) are constructed with nickel internal leads inside swaged MgO insulated cable to allow higher temperature measurements at the RTD element and to provide higher temperature lead protection along the sheath.

Input

Measured variable

Temperature (temperature-linear transmission behavior)

Measuring range

Construction	Model code (class and type of sensor)	max. range
Low temperature range	TH13-_____(A/C/E/G/J/L)_____	-50 to 200 °C (-58 to 392 °F)
	TH14-_____(A/C/E/G/J/L)_____	
	TH15-_____(A/C/E/G/J/L)_____	
High temperature range	TH13-_____(B/D/F/H/K/M)_____	-200 to 600 °C (-328 to 1 112 °F)
	TH14-_____(B/D/F/H/K/M)_____	
	TH15-_____(B/D/F/H/K/M)_____	



Options J, K, L, M are duplex platinum elements of two sensors inside the same sheath.

Output

Output signal

Generally, the measured value can be transmitted in one of two ways:

- Directly-wired sensors - sensor measured values forwarded without a transmitter.
- Via all common protocols by selecting an appropriate Endress+Hauser iTEMP temperature transmitter. All the transmitters listed below are mounted directly in the terminal head or as field transmitter and wired with the sensory mechanism.

Family of temperature transmitters

Thermometers fitted with iTEMP transmitters are an installation ready complete solution to improve temperature measurement by increasing accuracy and reliability, when compared to direct wired sensors, as well as reducing both wiring and maintenance costs.

PC programmable head transmitter TMT180 and TMT181

They offer a high degree of flexibility, thereby supporting universal application with low inventory storage. The iTEMP transmitters can be configured quickly and easily at a PC. Endress+Hauser offers the ReadWin 2000 configuration software for this purpose. This software can be downloaded free of charge at www.readwin2000.com. More information can be found in the Technical Information (see "Documentation" section).

HART® TMT182 head transmitter

HART® communication is all about easy, reliable data access and getting additional information about the measurement point more inexpensively. iTEMP transmitters integrate seamlessly into your existing control system and provide painless access to numerous diagnostic information.

Configuration with a hand-held (Field Xpert SFX100 or DXR375) or a PC with configuration program (FieldCare, ReadWin 2000) or configure with AMS or PDM. Details see Technical Information (see chapter "Documentation").

HART® programmable head transmitter iTEMP TMT82

The iTEMP TMT82 is a 2-wire device with two measurement inputs and one analog output. The device transmits both converted signals from resistance thermometers and thermocouples as well as resistance and voltage signals via the HART® communication. It can be installed as an intrinsically safe apparatus in Zone 1 hazardous areas and is used for instrumentation in the flat face terminal head to DIN EN 50446. Fast and easy operation, visualization and maintenance via PC using configuration software such as FieldCare, Simatic PDM or AMS.

Benefits are: Dual sensor input, maximum reliability, accuracy and long-term stability for critical processes, mathematical functions, monitoring of thermometer drift, backup function of the sensor, diagnostic functions of the sensor and sensor-transmitter matching based on the Callendar/Van Dusen coefficient. For more information, refer to the Technical Information (see chapter "Documentation").

PROFIBUS® PA TMT84 head transmitter

Universally programmable head transmitter with PROFIBUS® PA communication. Converting various input signals into a digital output signal. High accuracy over the complete ambient temperature range. Swift and easy operation, visualization and maintenance using a PC directly from the control panel, e. g. using operating software such as FieldCare, Simatic PDM or AMS.

Benefits are: dual sensor input, highest reliability in harsh industrial environments, mathematic functions, thermometer drift monitoring, sensor back-up functionality, sensor diagnosis functions and sensor-transmitter matching using Callendar-Van Dusen coefficients. Details see Technical Information (see chapter "Documentation").

FOUNDATION Fieldbus™ TMT85 head transmitter

Universally programmable head transmitter with FOUNDATION Fieldbus™ communication. Converting various input signals into a digital output signal. High accuracy over the complete ambient temperature range. Swift and easy operation, visualization and maintenance using a PC directly from the control panel, e. g. using operating software such as ControlCare from Endress +Hauser or the NI Configurator from National Instruments.

Benefits are: dual sensor input, highest reliability in harsh industrial environments, mathematic functions, thermometer drift monitoring, sensor back-up functionality, sensor diagnosis functions and sensor-transmitter matching using Callendar-Van Dusen coefficients. Details see Technical Information (see chapter "Documentation").

Galvanic isolation

	TMT82 HART®/ TMT84 PA / TMT85 FF	TMT180 Pt100 PCP	TMT181 multifunctional PCP	TMT182 HART®	TMT162 HART® Field transmitter	TMT142
Galvanic isolation (input/output)	U = 2 kV AC	-	U = 2 kV AC			

Power supply

Terminal assignment

Type of sensor connection

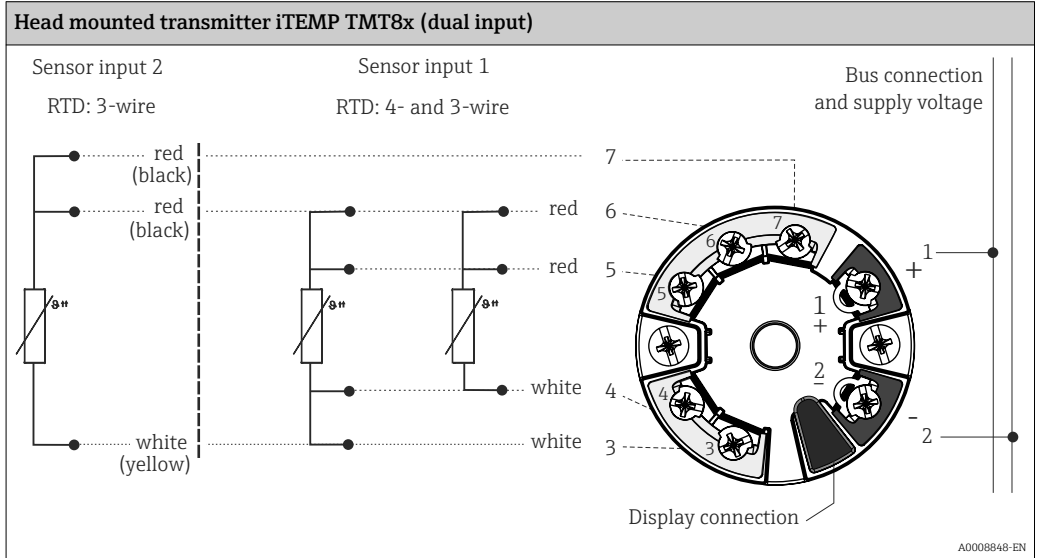
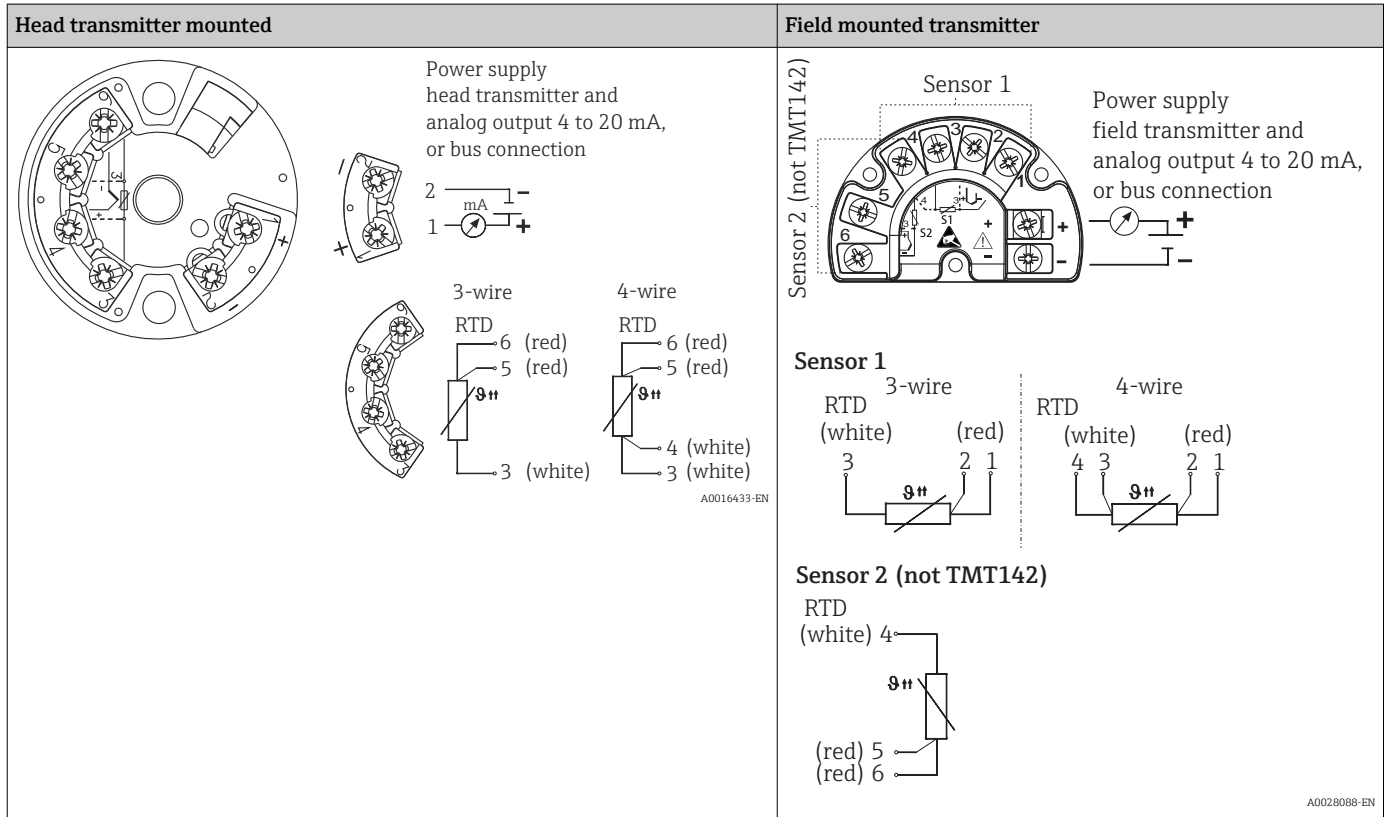

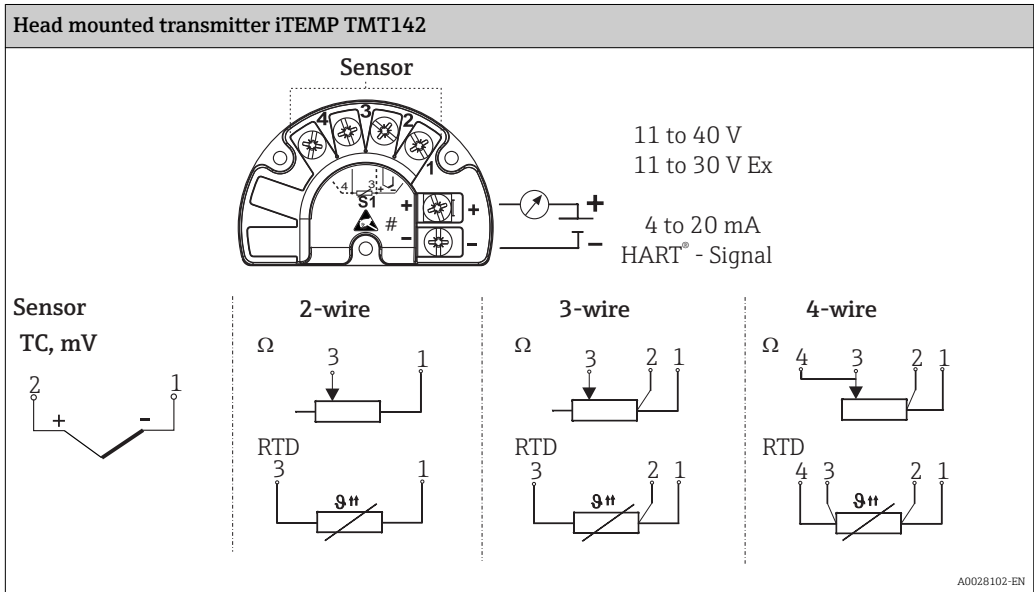
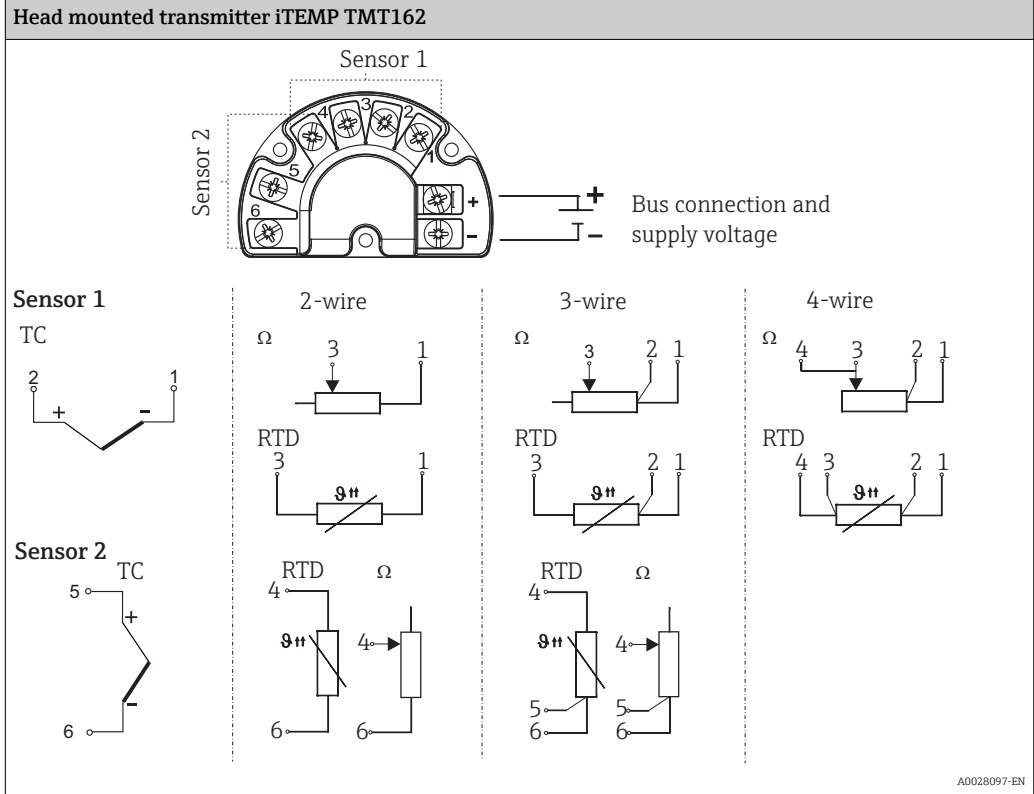

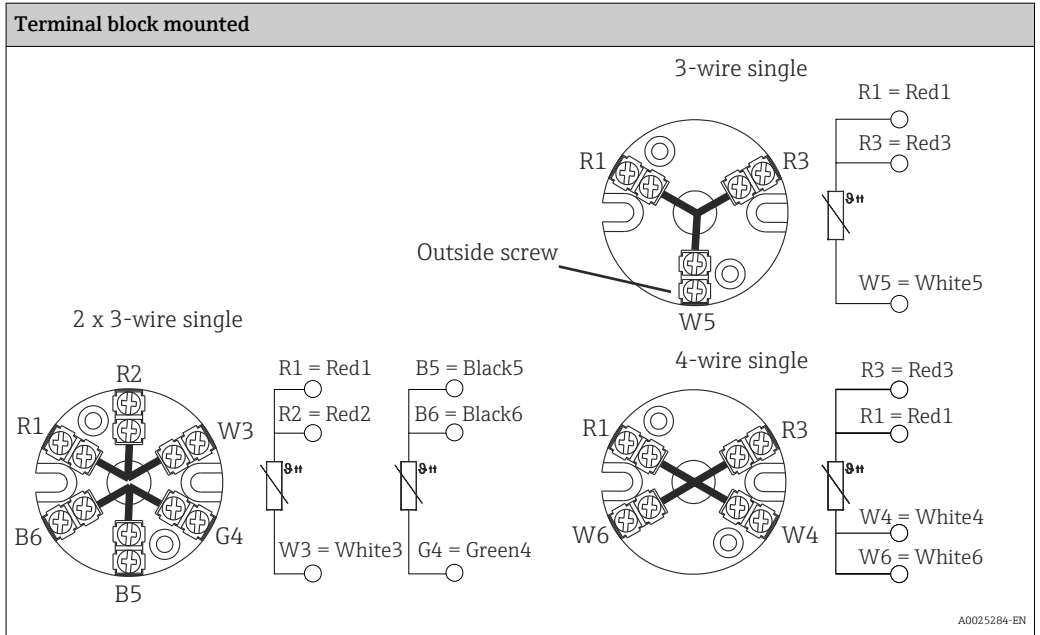

i The blocks and transmitters are shown as they sit inside the heads in reference to the conduit opening.

Fieldbus connector

Type (dimensions in mm (in))	Specification		
<p>Fieldbus connector to PROFIBUS® -PA or FOUNDATION Fieldbus™</p> <p>A M12 on PROFIBUS® -PA connector or 7/8-16 UNC on FOUNDATION Fieldbus™ connector</p>	<ul style="list-style-type: none"> Ambient temperature: -40 to 150 °C (-40 to 300 °F) Degree of protection IP 67 <p>Wiring diagram:</p> <table border="1"> <tr> <td> <p>PROFIBUS® -PA</p> <p>Pos. 1: grey (shield)</p> <p>Pos. 2: brown (+)</p> <p>Pos. 3: blue (-)</p> <p>Pos. 4: not connected</p> </td> <td> <p>FOUNDATION Fieldbus™</p> <p>Pos. 1: blue (-)</p> <p>Pos. 2: brown (+)</p> <p>Pos. 3: not connected</p> <p>Pos. 4: ground (green/yellow)</p> </td> </tr> </table>	<p>PROFIBUS® -PA</p> <p>Pos. 1: grey (shield)</p> <p>Pos. 2: brown (+)</p> <p>Pos. 3: blue (-)</p> <p>Pos. 4: not connected</p>	<p>FOUNDATION Fieldbus™</p> <p>Pos. 1: blue (-)</p> <p>Pos. 2: brown (+)</p> <p>Pos. 3: not connected</p> <p>Pos. 4: ground (green/yellow)</p>
<p>PROFIBUS® -PA</p> <p>Pos. 1: grey (shield)</p> <p>Pos. 2: brown (+)</p> <p>Pos. 3: blue (-)</p> <p>Pos. 4: not connected</p>	<p>FOUNDATION Fieldbus™</p> <p>Pos. 1: blue (-)</p> <p>Pos. 2: brown (+)</p> <p>Pos. 3: not connected</p> <p>Pos. 4: ground (green/yellow)</p>		

Wire specifications

24 AWG, 19 strand silver plated copper with 0.025 mm (0.010 in) PTFE extruded outer.

Electrical connection
Flying leads, standard 3" for wiring in terminal head, head mounted transmitter or terminal block mounted
Flying leads, 5½" for wiring with TMT162 or TMT142 assemblies

Design of leads
Flying leads 3" or 5½" with brass crimped sleeves

A0026119

Performance characteristics

Response time

63% response time per ASTM E644

RTD assembly TH15 without thermowell

Construction	RTD Ø ¼"
High temperature range	3 s
Low temperature range	9 s

Response time for the sensor assembly without transmitter.

Response time examples for RTD assemblies with thermowell TH13 and TH14

Construction	Stepped thermowell	Tapered thermowell	¾" straight thermowell
High temperature range	20 s	25 s	30 s
Low temperature range	25 s	30 s	35 s

Response times for RTD assemblies with thermowell are provided for general design guidance without transmitter.

When the temperature of a process media changes, the output signal of a RTD assembly follows this change after a certain time delay. The physical cause is the time related to heat transfer from the process media through the thermowell and the insert to the sensor element (RTD). The manner in which the reading follows the change in temperature of the assembly over time is referred to as the response time. Variables that influence or impact the response time are:

- Wall thickness of thermowell
- Spacing between RTD insert and thermowell
- Sensor packaging
- Process parameters such as media, flow velocity, etc.

Accuracy RTD corresponding to IEC 60751

Class	max. Tolerances (°C)	Temperature range	Characteristics
RTD max. error type TF - range: -50 to +500 °C			
Cl. AA, former 1/3 Cl. B	$\pm (0.1 + 0.0017 \cdot t ^{1})$	0 to +150 °C	
Cl. A	$\pm (0.15 + 0.002 \cdot t ^{1})$	-30 to +300 °C	
Cl. B	$\pm (0.3 + 0.005 \cdot t ^{1})$	-50 to +500 °C	
RTD max. error type WW - range: -196 to +600 °C			
Cl. AA, former 1/3 Cl. B	$\pm (0.1 + 0.0017 \cdot t ^{1})$	-50 to +250 °C	
Cl. A	$\pm (0.15 + 0.002 \cdot t ^{1})$	-100 to +450 °C	
Cl. B	$\pm (0.3 + 0.005 \cdot t ^{1})$	-196 to +600 °C	

1) |t| = absolute value °C

For measurement errors in °F, calculate using equations above in °C, then multiply the outcome by 1.8.

Transmitter specifications

	TMT82 HART®/ TMT84 PA / TMT85 FF	TMT180 Pt100 PCP	TMT181 multifunctional PCP	TMT182 HART®	TMT162 HART® Field transmitter	TMT142
Measurement accuracy	± typ. 0.25 °C (0.45 °F)	0.2 °C (0.36 °F), optional 0.1 °C (0.18 °F) or 0.08% ¹⁾	0.5 °C (0.9 °F) or 0.08% ¹⁾		≤ 0.105 °C (0.19 °F)	0.2 °C (0.36 °F)
Sensor current	I ≤ 0.3 mA	I ≤ 0.6 mA		I ≤ 0.2 mA	I ≤ 0.3 mA	

1) % is related to the adjusted measurement range (the larger value applies)

Transmitter long-term stability

≤ 0.1 °C (0.18 °F)/year or ≤ 0.05% / year

Data under reference conditions; % relates to the set span. The larger value applies.

Insulation resistance

Insulation resistance between terminals and probe sheath, test voltage 250 V.

- ≥ 100 MΩ at 25 °C (77 °F)
- ≥ 10 MΩ at 300 °C (572 °F)

Self heating

RTD elements are not self-powered and require a small current be passed through the device to provide a voltage that can be measured. Self-heating is the rise of temperature within the element itself, caused by the current flowing through the element. This self-heating appears as a measurement error and is affected by the thermal conductivity and velocity of the process being measured; it is negligible when an Endress+Hauser iTEMP temperature transmitter is connected.

Calibration specifications

3 point sensor calibration		
-40 to 0 °C (-40 to 32 °F)	0 to 100 °C (32 to 212 °F)	40 to 215 °C (104 to 420 °F)
Minimum length requirements for calibrated sensors = 6"		

Use option "B" (Block: Test; calibration) for RTD calibration, the three temperature points need to be specified in 5 °C (9 °F) increments.

The manufacturer provides comparison temperature calibrations from -40 to +215 °C (-40 to +420 °F) on the international temperature scale of 1990. Calibrations are traceable to standards maintained by the National Institute of Standards and Technology (NIST). Calibration services are in conformance with ASTM E220, IEC 17025 and ANSI/NC SL Z540-1-1994. The report of calibration is referenced to the serial number of the RTD assembly.

Three point calibrations are provided, given that the specified temperatures are within the recommended range and the minimum length requirements are met as specified. The minimum length is based on overall length 'x' of the spring loaded insert.

Installation

Orientation

No restrictions for installation orientation.

Installation instructions

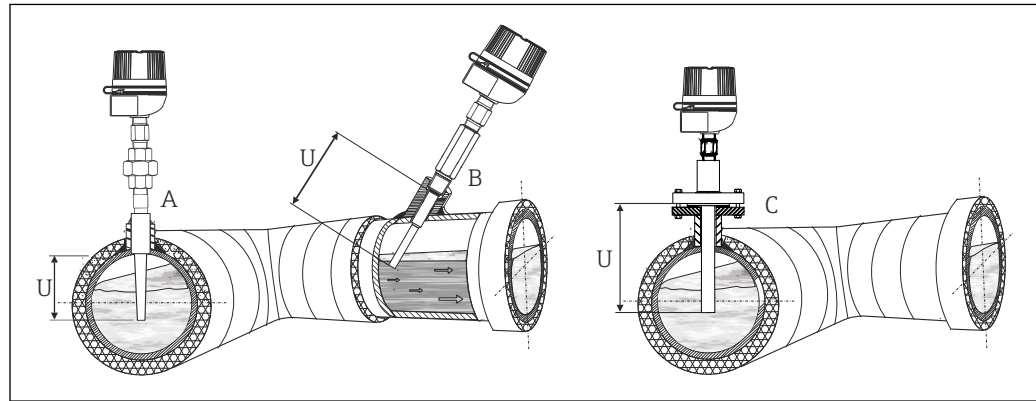

2 Examples for pipe installation - In pipes with a small cross section the sensor tip should reach or extend slightly past the center line of the pipe (=U).

- A TH13 assembly socket weld installation
- B Threaded, tilted installation of TH13 assembly
- C Flange installation of TH14 assembly

Immersion

Minimum immersion per ASTM E644, $\Delta T \leq 0.05 \text{ °C}$ (0.09 °F)

Immersion RTD assembly TH15 without thermowell

Construction	RTD Insert Ø ¼" Minimum Immersion (in)
High temperature range	1¼"
Low temperature range	¾"

For temperature assemblies with thermowell (TH13 and TH14) the minimum immersion is the depth to which the thermowell is immersed in the medium, measured from the tip. To minimize errors from ambient temperature the following minimum immersion lengths are recommended:

Construction	Minimum Immersion (in)
Stepped thermowell	2½"
Tapered thermowell	4½"
¾" straight thermowell	4"
Weld in thermowell	4½"

Environment

Ambient temperature range	Terminal head	Temperature in °C (°F)
	Without mounted head transmitter	Depends on the terminal head used and the cable gland or fieldbus connector, see "Terminal heads" section XREF "Housing".
	With mounted head transmitter	-40 to 85 °C (-40 to 185 °F)
	With mounted head transmitter and display	-20 to 70 °C (-4 to 158 °F)

Shock and vibration resistance 4G / 2 to 150 Hz as per IEC 60068-2-6

Process

Thermowells are used in measuring the temperature of a moving fluid in a conduit, where the stream exerts an appreciable force. The limiting value for the thermowells is governed by the temperature, the pressure and the speed of the medium, the immersion length, the materials of the thermowells and the medium, etc. Calculations for stress and vibration of thermowells can be done according to ASME PTC 19.3-1974 standard, please consult Endress+Hauser.

Mechanical construction

Design, dimensions All dimensions in inches. For the values related to this graphic please refer to the tables and equations below.

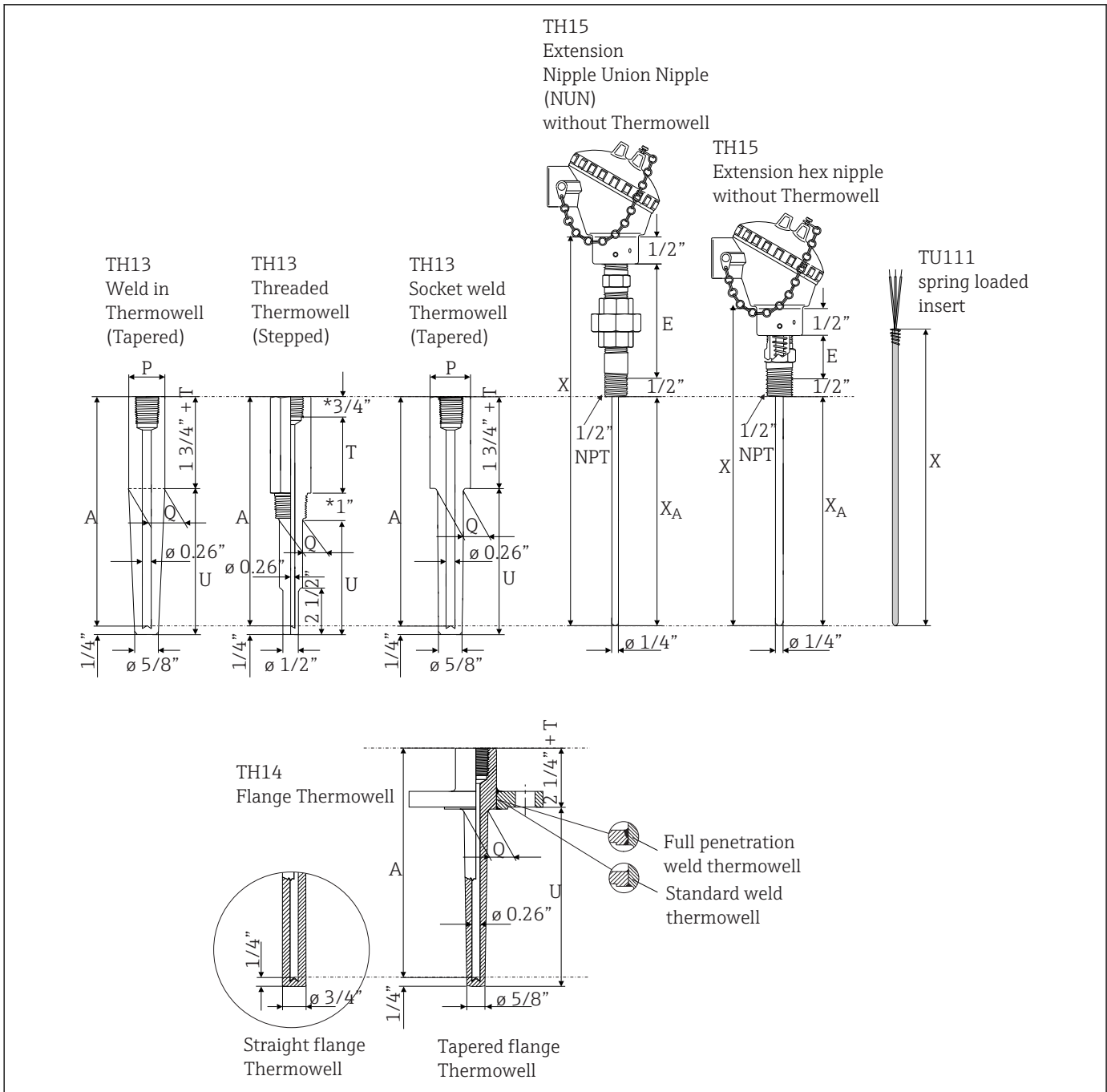

A0028120-EN

All thermowells are marked with:

- Material I.D.
- CRN# (Canadian Registration Number)
- Heat No.

Dimensions of TH13					
U	E	T	Process connection	Shape of Thermowell	Ø Q
2½", 4½", 7½", 10½" specified length 2" to 18" in ½" increments	Hex nipple = 1" or Nipple Union Nipple (NUN) = 4" or 7" Material: Steel or 316SS	3" or specified length 1" to 6" in ½" increments	½" NPT	Stepped (Standard duty) Tapered (Heavy duty)	5/8" 1 1/16"
			¾" NPT	Stepped (Standard duty) Tapered (Heavy duty)	¾" 7/8"
			1" NPT	Stepped (Standard duty) Tapered (Heavy duty)	7/8" 1 1/16"

Dimensions of TH13					
U	E	T	Process connection	Shape of Thermowell	Ø Q
			¾" Socket weld	Stepped (Standard duty) Tapered (Heavy duty)	¾" ¾"
			1" Socket weld	Stepped (Standard duty) Tapered (Heavy duty)	7/8" 1"
			¾" weld in	Tapered (Heavy duty)	1.050"
			1" weld in	Tapered (Heavy duty)	1.315"
Immersion length RTD sensor = Thermowell drilled length $X_A = A = U + 1\frac{1}{2}" + T$ Insert overall length $X = A + E + 1"$					
P = Pipe size ■ Nom. ¾"; Dia. = 1.050" ■ Nom. 1"; Dia. = 1.315"					

Dimensions of TH14 Flange rating: ASME B16.5				
U	E	T	Flange size	Ø Q, Tapered version
2", 4", 7", 10" specified length 2" to 18" in ½" increments	Hex nipple = 1" or Nipple Union Nipple (NUN) = 4" or 7" Material: Steel or 316SS	specified length 1" to 10" in ½" increments	1"	7/8"
			1 ½"	1 1/16"
			2"	1 1/16"
Immersion length RTD sensor - Thermowell drilled length $X_A = A = U + 2" + T$ Insert overall length $X = A + E + 1"$				

Dimensions of TH15 (without thermowell)	
Immersion length RTD sensor X_A	
4", 6", 9", 12", 14" specified length 4" to 41" in ½" increments	Hex nipple = 1" or Nipple Union Nipple (NUN) = 4" or 7"

Weight From 1 to 5.5 lbs

Material Process connections, thermowells and enclosures.
 The temperatures for continuous operation specified in the following table are only intended as reference values for use of the various materials in air and without any significant compressive load.

The maximum operation temperatures are reduced considerably in some cases where abnormal conditions such as high mechanical load occur or in aggressive media.

Material name	Short form	Recommended max. temperature for continuous use in air	Properties
AISI 316L/ 1.4404 1.4435	X2CrNiMo17-12-2 X2CrNiMo18-14-3	650 °C (1200 °F) ¹⁾	<ul style="list-style-type: none"> ▪ Austenitic, stainless steel ▪ High corrosion resistance in general ▪ Particularly high corrosion resistance in chlorine-based and acidic, non-oxidizing atmospheres through the addition of molybdenum (e.g. phosphoric and sulfuric acids, acetic and tartaric acids with a low concentration) ▪ Increased resistance to intergranular corrosion and pitting ▪ Compared to 1.4404, 1.4435 has even higher corrosion resistance and a lower delta ferrite content
AISI 316/1.4401	X2CrNiMo17-12-2	650 °C (1200 °F) ¹⁾	<ul style="list-style-type: none"> ▪ Austenitic, stainless steel ▪ High corrosion resistance in general ▪ Particularly high corrosion resistance in chlorine-based and acidic, non-oxidizing atmospheres through the addition of molybdenum (e.g. phosphoric and sulfuric acids, acetic and tartaric acids with a low concentration)

- 1) Can be used to a limited extent up to 800 °C (1472 °F) for low compressive loads and in non-corrosive media. Please contact your Endress+Hauser sales team for further information.

Terminal heads

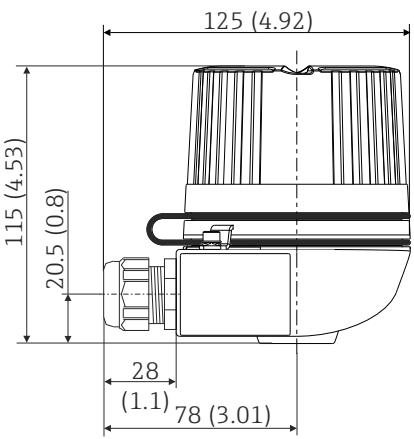
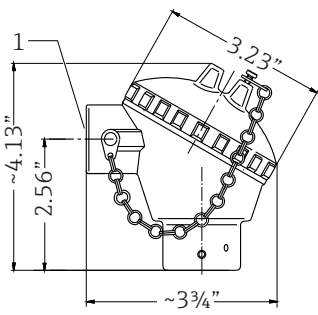
Type of housing (dimensions in mm (in))	Specification
<p>TA30H</p>  <p style="text-align: right; font-size: small;">A0009831</p>	<ul style="list-style-type: none"> ■ Flameproof (XP) version, explosion-protected, captive screw cap ■ Degree of protection: IP66/68 ■ Temperature: -50 to 150 °C (-58 to 302 °F) for rubber seal without cable gland (observe max. permitted temperature of the cable gland!) ■ Material: aluminum; polyester powder coated ■ Cable entry glands: 1/2" NPT, 3/4" NPT, M20x1.5, only thread G1/2"; plug: M12x1 PA, 7/8" FF ■ Extension neck/thermowell connection: 1/2" NPT ■ Color of head: blue, RAL 5012 ■ Color of cap: gray, RAL 7035 ■ Weight: 860 g (30.33 oz) ■ Head transmitter optionally available with TID10 display
<p>Terminal head Al (dimensions in inch)</p>  <p>1 1/2" or 3/4" NPT cable entry</p> <p style="text-align: right; font-size: small;">A0028079</p>	<ul style="list-style-type: none"> ■ Material: Die-cast Aluminium head ■ Sensor connection: 1/2" NPT Female ■ Cable entry: 1/2" NPT or 3/4" NPT Female 1/2" NPT has got Al reducer bushing ■ Body paint: Spray SPU, RAL5012 Cover paint: Spray SPU, RAL7035 ■ Coating thread (body-cover), lubricant acc. Endress+Hauser standard, MgO coating; benefits include ease of opening/closing cover and improved thread engagement. Improves life time of the terminal head. Degree of protection NEMA Type 4x Encl. (IP 66/68)

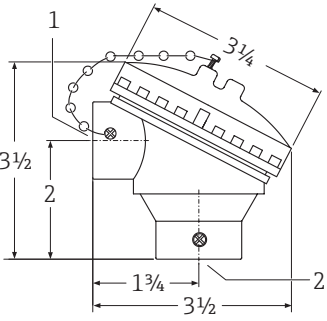
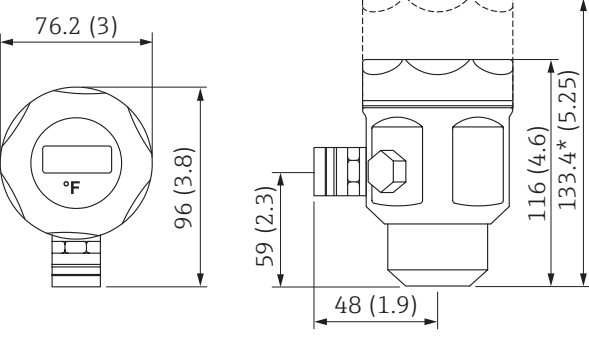
Type of housing (dimensions in mm (in))	Specification
<p>Terminal head plastic (dimensions in inch)</p>  <p>1 1/2" or 3/4" NPT cable entry 2 1/2" NPT sensor connection</p> <p style="text-align: right;">A0028082</p>	<ul style="list-style-type: none"> ■ Polypropylene, FDA compliant ■ Sensor connection: 1/2" NPT Female ■ Cable entry: 1/2" NPT or 3/4" NPT Female 1/2" NPT with nylon reducer bushing (FDA compliant) ■ Degree of protection NEMA Type 4x Encl.
 <p>* dimensions with optional display</p> <p style="text-align: right;">A0005938</p>	<ul style="list-style-type: none"> ■ Material: Deep drawn stainless steel AISI 316L SS (hygienic design) ■ Optional with display and/or head transmitter ■ Sensor connection: 1/2" NPT female ■ Cable entry: 1/2" NPT female ■ Degree of protection NEMA Type 4x Encl. (IP66) ■ Display: <ul style="list-style-type: none"> 4 digits 7-segments LC display (loop powered) Maximum error: 0.1% of programmed range Loop drop: 2.5 V at 22 mA ■ Max. ambient temperature: -20 to 70 °C (-4 to 160 °F) <p>The programming is executed through 3 keys mounted on the bottom of the display.</p>

Head transmitters

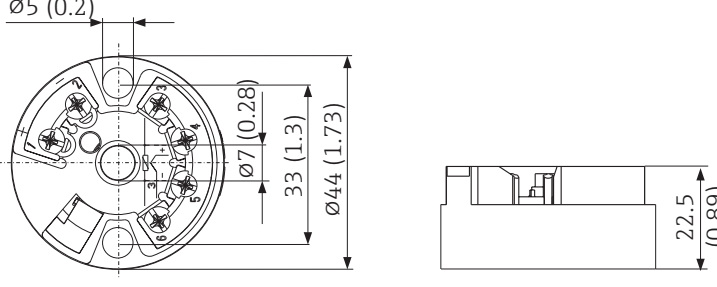
iTEMP TMT18x	Specification
 <p style="text-align: right;">A0016380</p>	<ul style="list-style-type: none"> ■ Material: Housing (PC), Potting (PUR) ■ Terminals: Cable up to max. 2.5 mm² (16 AWG) (secure screws) or with wire end ferrules ■ Eyelets for easy connection of a HART®-handheld terminal with alligator clips ■ Degree of protection NEMA Type 4x Encl. (see also type of terminal head) <p>Details see Technical Information (see chapter "Documentation")</p>

iTEMP TMT8x	Specification
	<ul style="list-style-type: none"> Spring range $L \geq 5$ mm (0.2 in), see Pos. A Fixing elements for pluggable measured value display, see Pos. B Interface for contacting measured value display, see Pos. C Material (RoHS-compliant) Housing: PC Potting: PU Terminals: Screw terminals (cable up to max. 2.5 mm² (16 AWG)) or spring terminals (e. g. from 0.25 to 0.75 mm² (24 to 18 AWG) for flexible wires with wire-end ferrules with plastic ferrule) Degree of protection NEMA Type 4x Encl. (see also type of terminal head) <p>Details see Technical Information (see chapter "Documentation")</p>

Pluggable display TID10 as option	Specification
	<ul style="list-style-type: none"> Displays the actual measured value and the measurement point identification Displays fault events in inverse color with channel ident and diagnostics code DIP-switches on the rear for hardware set-up, e. g. PROFIBUS® PA bus address <p>Display is only available with suitable terminal head with display window, e.g. TA30</p>

Field housings

iTEMP TMT162 field transmitter

Field transmitter with universal communication (HART®, PA, FF) and blue backlit display. Can be read easily from a distance, in sunlight and at night. Large measurement value, bargraph and fault indication display. Benefits are: dual sensor input, highest reliability in harsh industrial

environments, mathematic functions, thermometer drift monitoring and sensor back-up functionality, corrosion detection.

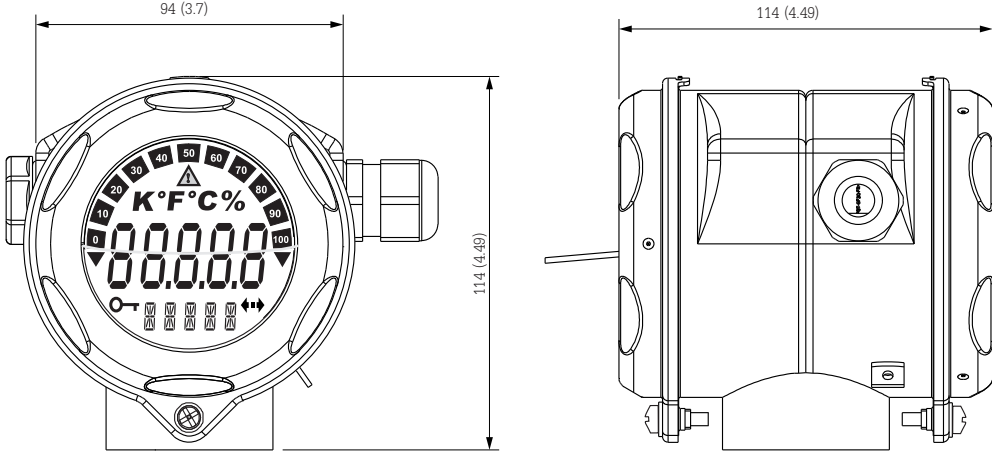
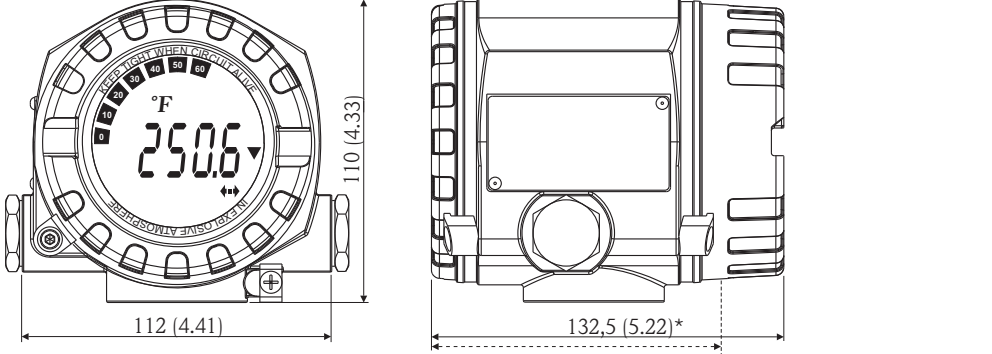
Type of transmitter (dimensions in mm (in))	Specification
<p>Temperature field transmitter iTEMP TMT162 for hygienic applications</p>  <p style="text-align: right;">A0016655</p>	<ul style="list-style-type: none"> ■ Material: Stainless steel 1.4435 (AISI 316L) for hygienic applications (T17 housing) ■ Separate electronics compartment and connection compartment ■ Display rotatable in 90° increments ■ Cable entry: 2 x ½" NPT ■ Degree of protection (IP69K) ■ Brilliant blue backlit display with ease of visibility in bright sunshine or pitch darkness ■ Gold plated terminals to avoid corrosion and additional measurement errors <p>Details see Technical Information (see chapter "Documentation")</p>
<p>Temperature field transmitter iTEMP TMT162 for general purpose</p>  <p>* Dimensions without display = 112 mm (4.41 in)</p> <p style="text-align: right;">A0016656</p>	<ul style="list-style-type: none"> ■ Material: Die-cast aluminium housing AlSi10Mg/AlSi12 with powder coating on polyester base ■ Separate electronics compartment and connection compartment ■ Display rotatable in 90° increments ■ Cable entry: 2 x ½" NPT ■ Degree of protection: NEMA Type 4x Encl. (IP67) ■ Brilliant blue backlit display with ease of visibility in bright sunshine or pitch darkness ■ Gold plated terminals to avoid corrosion and additional measurement errors <p>Details see Technical Information (see chapter "Documentation")</p>

Field transmitter TMT142 - Single compartment housing

Field transmitter with HART® communication. The one channel TMT142 allows for cost effective replacement of smaller transmitters with tiny display and old style analog transmitters. Large and brilliant blue backlit display. Regardless of whether you install the transmitter in a dark location or in

direct sunlight, you still get a clear temperature reading. Reliable temperature measurement through advanced diagnostics. For details, see Technical Information.

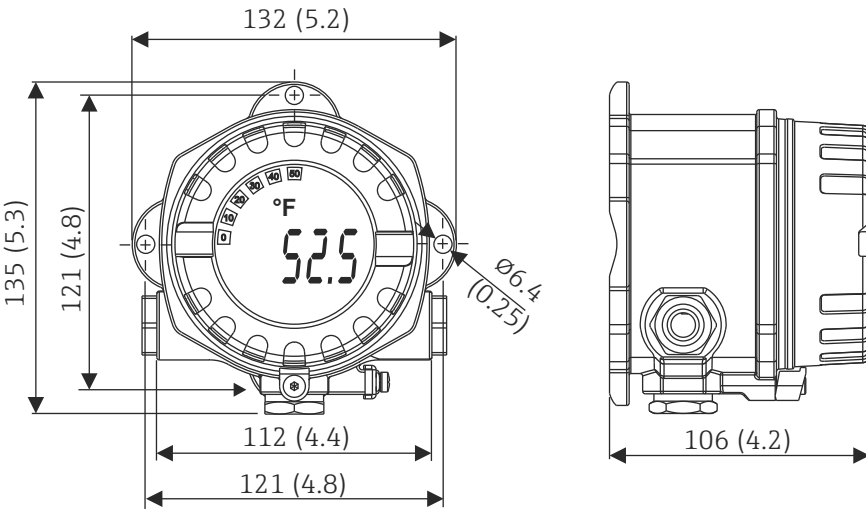
Type of transmitter (dimensions in mm (in))	Specification
<p>Temperature field transmitter iTEMP TMT142</p> 	<ul style="list-style-type: none"> ▪ Material: Die-cast aluminium housing AlSi10Mg/ AlSi12 with powder coating on polyester base ▪ Display rotatable in 90° increments ▪ Cable entry: 3 x 1/2" NPT ▪ Degree of protection NEMA Type 4x Encl. (IP67) ▪ Brilliant blue backlit display with ease of visibility in bright sunshine or pitch darkness ▪ Gold plated terminals to avoid corrosion and additional measurement errors <p>Details see Technical Information (see chapter "Documentation")</p>

Certificates and approvals

CE Mark	The device meets the legal requirements of the EC directives if applicable. Endress+Hauser confirms that the device has been successfully tested by applying the CE mark.
Other standards and guidelines	<ul style="list-style-type: none"> ▪ IEC 60529: Degree of protection of housing (IP code) ▪ IEC 61010-1: Safety requirements for electrical equipment for measurement, control, and laboratory use. ▪ ASTM E644: American society for testing and materials, standard test methods for testing industrial resistance thermometers. ▪ NEMA - ANSI / NEMA 250: Standardization association for the electrical industry. ▪ IEC 60751: Industrial platinum resistance thermometer ▪ ASME PTC 19.3 - 1974: Performance test codes
UL	Temperature transmitter are recognized components to UL 3111-1 (iTEMP Series).
CSA GP	The installed and assembled transmitters (iTEMP Series) are CSA GP approved.

Ordering information

Detailed ordering information is available from the following sources:

- In the Product Configurator on the Endress+Hauser website: www.endress.com → Select your country → Products → Select measuring technology, software or components → Select the product (picklists: measurement method, product family etc.) → Device support (right-hand column): Configure the selected product → The Product Configurator for the selected product opens.
- From your Endress+Hauser Sales Center: www.addresses.endress.com

Product Configurator - the tool for individual product configuration







- Up-to-the-minute configuration data
 - Depending on the device: Direct input of measuring point-specific information such as measuring range or operating language
 - Automatic verification of exclusion criteria
 - Automatic creation of the order code and its breakdown in PDF or Excel output format
 - Ability to order directly in the Endress+Hauser Online Shop

Accessories

Various accessories, which can be ordered with the device or subsequently from Endress+Hauser, are available for the device. Detailed information on the order code in question is available from your local Endress+Hauser sales center or on the product page of the Endress+Hauser website:

www.endress.com.



Communication-specific accessories

Configuration kit TXU10	Configuration kit for PC-programmable transmitter with setup software and interface cable for PC with USB port Order code: TXU10-xx
Commubox FXA195 HART	For intrinsically safe HART communication with FieldCare via the USB interface.  For details, see "Technical Information" TI00404F
Commubox FXA291	Connects Endress+Hauser field devices with a CDI interface (= Endress+Hauser Common Data Interface) and the USB port of a computer or laptop.  For details, see "Technical Information" TI00405C
HART Loop Converter HMX50	Is used to evaluate and convert dynamic HART process variables to analog current signals or limit values.  For details, see "Technical Information" TI00429F and Operating Instructions BA00371F
Wireless HART adapter SWA70	Is used for the wireless connection of field devices. The WirelessHART adapter can be easily integrated into field devices and existing infrastructures, offers data protection and transmission safety and can be operated in parallel with other wireless networks with minimum cabling complexity.  For details, see Operating Instructions BA061S
Fieldgate FXA320	Gateway for the remote monitoring of connected 4-20 mA measuring devices via a Web browser.  For details, see "Technical Information" TI00025S and Operating Instructions BA00053S
Fieldgate FXA520	Gateway for the remote diagnostics and remote configuration of connected HART measuring devices via a Web browser.  For details, see "Technical Information" TI00025S and Operating Instructions BA00051S
Field Xpert SFX100	Compact, flexible and robust industry handheld terminal for remote configuration and for obtaining measured values via the HART current output (4-20 mA).  For details, see Operating Instructions BA00060S

Service-specific accessories

Accessories	Description
Applicator	<p>Software for selecting and sizing Endress+Hauser measuring devices:</p> <ul style="list-style-type: none"> ▪ Calculation of all the necessary data for identifying the optimum measuring device: e.g. pressure loss, accuracy or process connections. ▪ Graphic illustration of the calculation results <p>Administration, documentation and access to all project-related data and parameters over the entire life cycle of a project.</p> <p>Applicator is available:</p> <ul style="list-style-type: none"> ▪ Via the Internet: https://wapps.endress.com/applicator ▪ On CD-ROM for local PC installation.
Configurator ^{+temperature}	<p>Software for selecting and configuring the product depending on the measuring task, supported by graphics. Includes a comprehensive knowledge database and calculation tools:</p> <ul style="list-style-type: none"> ▪ For temperature competence ▪ Quick and easy design and sizing of temperature measuring points ▪ Ideal measuring point design and sizing to suit the processes and needs of a wide range of industries <p>The "Configurator" is available: On request from your Endress+Hauser sales office on a CD-ROM for local PC installation.</p>
W@M	<p>Life cycle management for your plant W@M supports you with a wide range of software applications over the entire process: from planning and procurement, to the installation, commissioning and operation of the measuring devices. All the relevant device information, such as the device status, spare parts and device-specific documentation, is available for every device over the entire life cycle.</p> <p>The application already contains the data of your Endress+Hauser device. Endress+Hauser also takes care of maintaining and updating the data records.</p> <p>W@M is available:</p> <ul style="list-style-type: none"> ▪ Via the Internet: www.endress.com/lifecyclemanagement ▪ On CD-ROM for local PC installation.
FieldCare	<p>FDT-based plant asset management tool from Endress+Hauser. It can configure all smart field units in your system and helps you manage them. By using the status information, it is also a simple but effective way of checking their status and condition.</p> <p> For details, see Operating Instructions BA00027S and BA00059S</p>

System components

Accessories	Description
Energy manager RMS621	<p>Accurate and reliable calculations for the monitoring and control of energy consumption (both produced and consumed) according to international standards.</p> <p> For details, see the "Technical Information" document TI092R/24/AE</p>
Deltabar S/Cerabar S	<p>Pressure transmitters with diaphragm seal for level measurements in gases or liquids.</p> <p> For details, see "Technical Information"</p>

Documentation

- Brief operating instructions**
- TH13 RTD assembly in thermowell (KA00190R/09/)
 - TH14 RTD assembly in flanged thermowell (KA00192R/09/)
 - TH15 RTD assembly spring loaded (KA00195R/09/)

- Technical information**
- Temperature head transmitter:
- iTEMP HART® TMT82 (TI01010T/09/)
 - iTEMP PROFIBUS PA TMT84 (TI00138R/09/)
 - iTEMP FF TMT85 (TI00134R/09/)
 - iTEMP HART® TMT142 (TI00107R/09/)
 - iTEMP HART® TMT162 (TI00086R/09/)
 - iTEMP PCP TMT181 (TI00070R/09/)
 - iTEMP Pt TMT180 (TI00088R/09/)
 - iTEMP HART® TMT182 (TI00078R/09/)

- Application example**
- Technical information:
- Energy manager RMS621 (TI00092R/09/)
 - Cerabar S (TI00383P/00/)
 - Deltabar S (TI00384P/00/)

www.addresses.endress.com
