



Compact length measuring instrument



Millimar C 1200 M/T

Operating Instructions

Valid from firmware version 1.7

3723034

Mahr GmbH

Carl-Mahr-Straße 1

37073 Göttingen

Tel. +49 551 7073 0

info@mahr.com, www.mahr.com

Dear customer,

Congratulations on choosing a product by Mahr GmbH. We kindly request that you follow the instructions below to ensure the long-term precision of your measuring instrument.

We operate a policy of continuous improvement and are constantly developing our products. Therefore, it is possible that there may be slight differences between the text and illustrations in this document and the measuring instrument in your possession, especially with regard to type designations. We reserve the right to make changes to the design and scope of supply, the right to undertake further technical developments, and all rights relating to translation of this documentation.

© by Mahr GmbH, Germany

The following symbols are used in these operating instructions:

**General information****Important note****Caution, hazard**

Failure to follow instructions marked with this symbol can cause inaccurate results and lead to equipment damage.

Introduction**Permitted uses**

The Millimar C 1200 M/T is an electronic length measuring and evaluation instrument for use in production. An inductive probe can be connected.

The operating, maintenance and repair information detailed in these operating instructions must be followed.

To bring about the greatest benefits from this measuring instrument, you must read the operating instructions before placing it into operation.

The measuring device reaches its highest accuracy after a warm-up time of at least 30 minutes.

The Millimar C 1200 M/T can be operated either with batteries, rechargeable batteries or the supplied mains adapter. **Rechargeable batteries are not charged in the device!**

The scope of delivery of the length measuring instrument includes:

- Measuring instrument
- Power supply unit with interchangeable adapter
- Operating instructions

! Forfeiture of warranty

Service work caused by viruses that were introduced via a network connection or other data carrier, are generally excluded from warranty services.

Storage temperatures below -10°C or above $+50^{\circ}\text{C}$ and relative humidity levels above 85% will invalidate the warranty for the instrument.

Safety information

This measuring instrument complies with the relevant safety regulations. It was dispatched from our production facility in a flawless condition and perfect working order. However, failure to follow the instructions given below can cause personal injury or death.

1. Before you connect up and use the measuring instrument for the first time, please read the accompanying documentation. Follow the safety precautions detailed in the operating instructions.
2. Keep the documentation close to the measuring instrument ready for quick reference.
3. Follow all safety precautions, accident prevention regulations and internal company rules and guidelines. If necessary you should request further information from your company safety officer.
4. Before connecting up this measuring instrument, please check the local mains supply voltage to ensure that it is within the working range of the AC adaptor (100 V - 240 V, 50 Hz - 60 Hz). If they do not match, this measuring instrument must not be connected under any circumstances!
5. The instrument may only be connected to a grounded power socket which complies with the regulations of the local power supply company. This also applies to any extension cables that are used.
6. Only use original and intact AC adapters.
7. When connecting inductive probes ensure that the plugs are firmly screwed onto the connection sockets.
8. Do not drop the instrument and make sure it is positioned securely.
9. Do not operate the instrument in areas where there is a risk of explosion and do not expose it to direct sunlight!
10. Do not clean the membrane keypad with solvent-based cleaning agents.
11. Before opening the housing, disconnect the power supply.
12. The test and measuring equipment, for which the Millimar is used, are subject to inspection equipment monitoring. For this reason, regular inspection equipment monitoring performed by either the user or Mahr Service must ensure compliance to the specified error limits for the test and measuring equipment.

Important notes prior to using the length measuring instrument

- The measuring instrument may only be used for its intended purpose. No liability will be accepted for damages caused by other usage or as a result of the incorrect application of this measuring instrument.
- Should your specific measuring task not be solved with this measuring instrument, please contact us so we can help solve your measuring task with a different instrument. Please inform us about your measuring task.
- **Battery**



- **Not rechargeable**
- **Do not incinerate**
- **Dispose off as prescribed**



Do not use an electric marking tool.

Disposal information

Electronic equipment which was purchased from us after March 23, 2006 can be returned to us. We will dispose of this equipment in an environmentally-friendly way in accordance with the applicable EU Directives WEEE (Waste Electrical and Electronic Equipment and the German National - Electrical and Electronic Equipment Act, ElektroG).

Confirmation of traceability

We declare, with sole responsibility, that this product conforms with standards and technical data as specified in our sales documents (operating instructions, leaflet, catalog).

We certify that the testing equipment used to check this product, and guaranteed by our Quality Assurance, is traceable to national standards.

Thank you for placing your trust in us by purchasing this product.

EU Declaration of Conformity



This measuring instrument conforms to the applicable EU directives.

A copy of the Declaration of Conformity can be requested from the following address:
Mahr GmbH, Standort Esslingen, Reutlinger Str. 48,
73728 Esslingen, Germany, or can be downloaded from:
www.mahr.com/de/Leistungen/Fertigungsmesstechnik/Produkte

Order no.	Last modification	Version
3723034	20.06.2020	Valid from firmware version 1.7

Table of Contents

1. Delivery and connection

1.1	Unpacking	8
1.2	Scope of delivery	9
1.3	Symbols	10
1.4	Operating elements and interfaces	12
1.4.1	Display and operating keys	12
1.4.2	Interfaces	12
1.4.3	Battery compartment.....	13

2. Initial operation (basic configuration)

2.1	Switching ON	14
2.2	Selecting the display language	14
2.3	Setting the measurement unit	14
2.4	Selecting the measuring probe	15
2.5	Display of probe compatibility	15
2.6	Scaling the analog display	16
2.6.1	In static measuring mode (standard)	16
2.6.2	In dynamic measuring mode (max, min, max-min)	16
2.7	Connecting the measuring probe	16
2.8	Selecting the probe type	17
2.9	Setting up the probe.....	18
2.10	Switching OFF	19

3. Measurement menu

3.1	Selecting the master	20
3.2	Selecting the nominal value	21
3.3	Selecting the tolerance	22
3.4	Selecting the formula	24
3.5	Selecting the function.....	25
3.6	Selecting the factor	26

4. Display menu

4.1	Selecting the resolution.....	27
4.2	Selecting the display style.....	28
4.3	Selecting the color scheme.....	29
4.4	Centering the display	30
4.5	Setting the brightness	31

5. Setup menu

5.1	Selecting the language	32
5.2	Selecting the unit of measurement	33
5.3	Selecting the probe type	34
5.4	Selecting ECO mode	35
5.5	Compatibility information	36

6. System menu

6.1	Selecting absolute mode.....	37
6.2	Customer calibration	38
6.2.1	Enabling customer calibration.....	38
6.2.2	Executing a probe calibration.....	39
6.2.3	Conducting a factory standard calibration.....	41
6.2.4	Executing a customer calibration reset.....	44
6.3	Activating a factory calibration	46
6.4	Resetting to factory settings.....	47
6.5	Activating the menu lock	48
6.6	Requesting firmware version and serial number.....	49

7. Description of the interfaces

7.1	Suitable data connection cables	51
7.2	Interfaces: Opto RS232C, Digimatic, USB.....	51
7.3	Data transmission parameters	52

8. Technical data

8.1	Compact length measuring instrument Millimar C1200	53
8.2	Compatible probes for Millimar C1200.....	54

9. Spare parts

9.1	Available spare parts	55
-----	-----------------------------	----

1. Delivery and connection



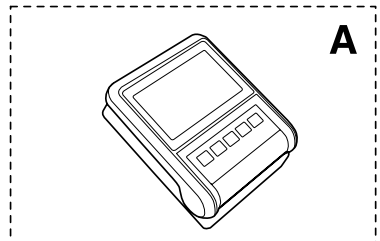
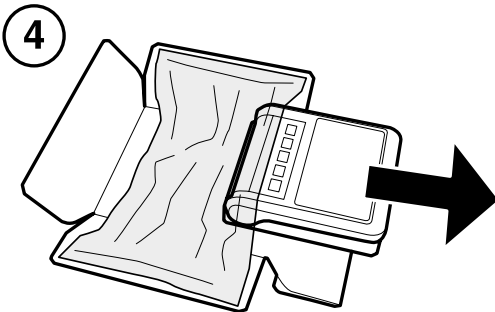
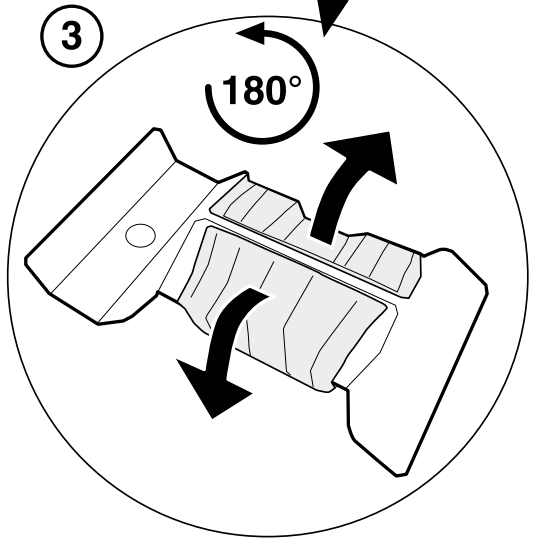
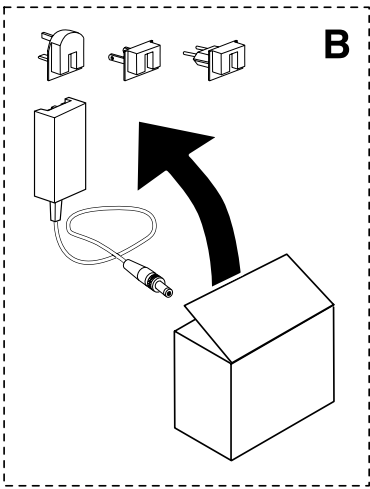
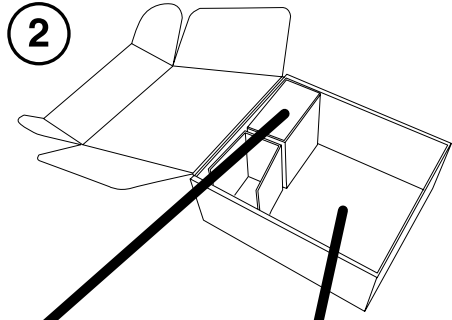
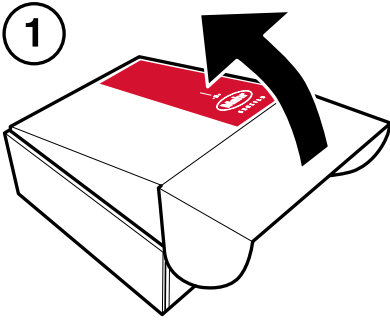



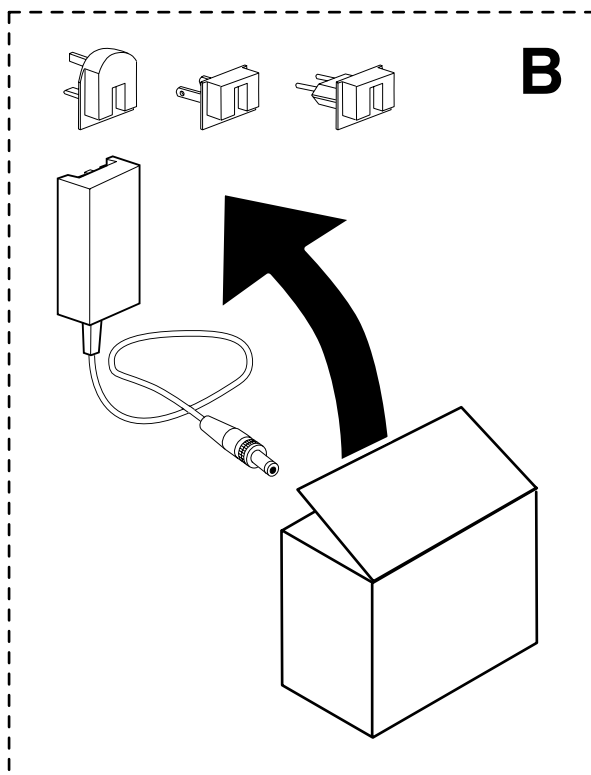
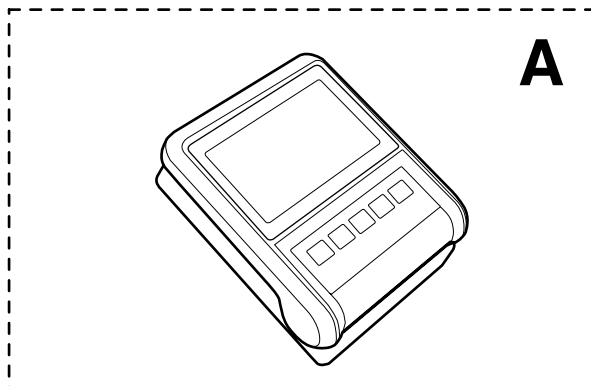





1.1 Unpacking











1.2 Scope of delivery



1.3 Symbols

- Select menu 
- Set zero point (RESET) 
- Reduce the resolution 
- Increase the resolution 
- Start data transmission 
- Scroll up 
- Scroll down 
- Scroll to the right 
- Scroll to the left 
- Confirm 
- Cancel 
- Exit menu 

- Battery mode 
- Change batteries 
- Battery low 
- Mains power supply mode 
- Formula measuring combination **+A -A**
- Data is been transferred **DATA**
- Factor is not equal to 1 **FACTOR**
- Activated tolerance **TOL**
- Dynamic measuring functions **(MAX), (MIN), (MAX-MIN)**
- Start dynamic measurement 
- Pause dynamic measurement 
- Stop dynamic measurement 
- Reset dynamic measurement 

1.4 Operating elements and interfaces

1.4.1 Display and operating keys



1.4.2 Interfaces

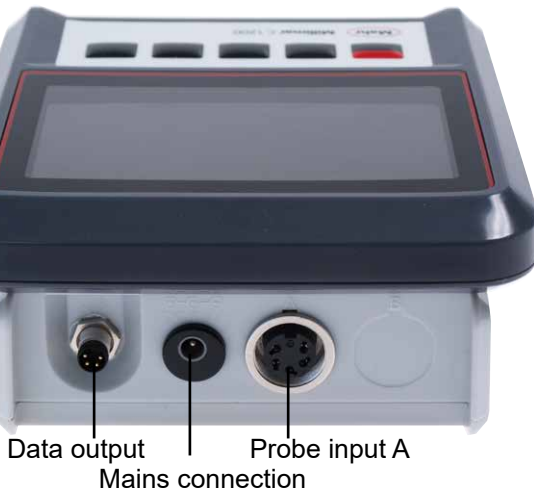

1.4.3 Battery compartment

The battery compartment is integrated in the base

- Turn the measuring instrument by 180°
- Remove locking screw **1**
- Push in tab **2** on the battery compartment cover and lift it off
- Correctly insert five type AA batteries or rechargeable batteries

! **Observe polarity of the batteries!**

- Close the battery compartment cover in reverse order.

Battery compartment cover

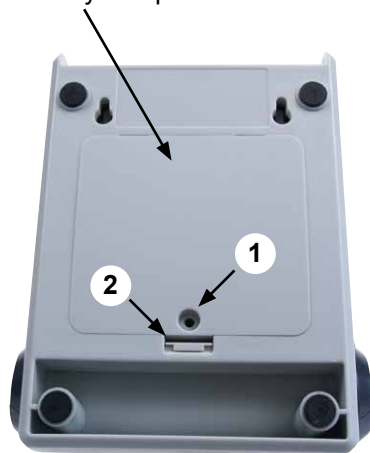

 If connected to the mains power supply, the measuring instrument will automatically switch to mains power supply.

The rechargeable batteries are not recharged during mains power operation!

Battery compartment

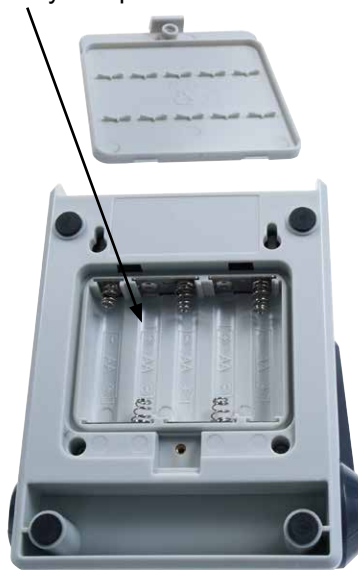

2. Initial operation

2.1 Switching ON

- Connect the mains power supply unit to the measuring instrument via the mains power supply socket and/or insert the batteries (rechargeable).



- Press the ON / OFF key

=> The following appears on the display:

Start screen



2.2 Selecting the display language

- Select the required language with ▼ or ▲
- Press ✓ to confirm

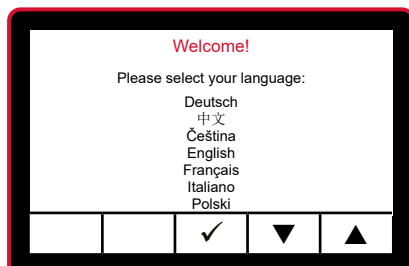

2.3 Setting the measurement unit

- Select the required measurement unit with ▼ or ▲
- Press ✓ to confirm

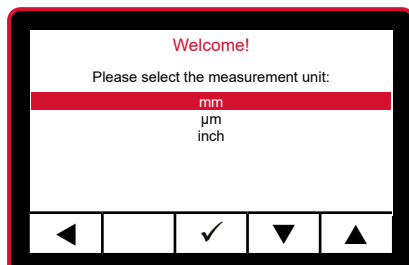

2.4 Selecting the measuring probe

- Select the required **probe type** with ▼ or ▲.
- => For compatible probes, see Chapter 8.2, page 54
- Press ✓ to confirm

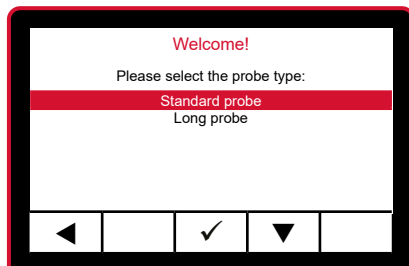

2.5 Display of probe compatibility

The display shows the probe compatibility for approx. 3 seconds.



This display appears after commissioning when the instrument is switched on and can be switched off under Setup/Compatibility Info.



2.6 Scaling the analog display

=> Select the functions (max, min, max-min, standard), see section 3.5

2.6.1 In static measuring mode (standard)

- Select required resolution with ►◀ or ◀►

Static measuring mode

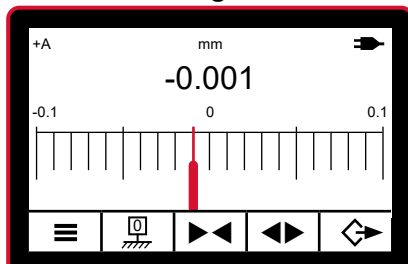

2.6.2 In dynamic measuring mode (max, min, max-min)

- Select required resolution with ►◀ or ◀►.
- Change the scaling direction by pressing and holding the ◀► key

Dynamic measuring mode

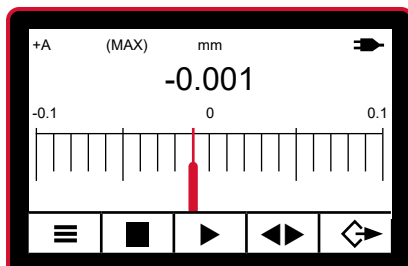

2.7 Connecting the measuring probe

- Connect the measuring probe to probe input A



Probe input A

2.8 Selecting the probe type

- Press the ON / OFF key

=> **Standard menu** appears

- Select the **Setup** menu with ► or ◀

The display shows the probe compatibility for approx. 3 seconds.

-  This display appears after commissioning when the instrument is switched on and can be switched off under Setup/ Compatibility Info.

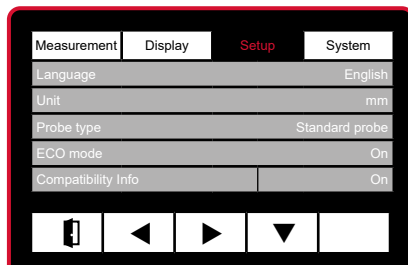

- Select the **Probe type** submenu with ▼ or ▲
- Press ✓ to confirm or press ✘ to cancel the selection

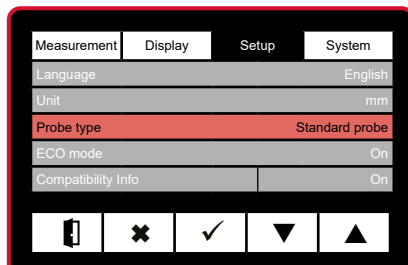

- Select the required **probe type** with ▼ or ▲.

=> For compatible probes, see Chapter 8.2, page 54

- Press ✓ to confirm or ✘ to cancel the selection
- Press the ON / OFF key to exit the input menu.

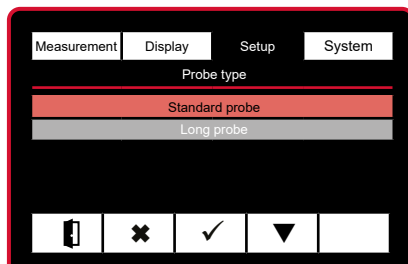

! The device guarantees the highest accuracy after approx. 30 min operating time. The measuring probe should be mechanically set to the electrical zero point before the first measurement is conducted. Setting mode that indicates the raw value or absolute value of the probe should be used for this purpose.

2.9 Setting up the probe

- Press the ON / OFF key



=> **Standard menu** appears

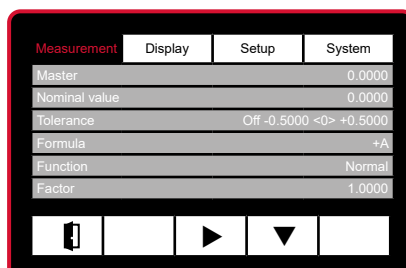

- Select the **System** menu with ►

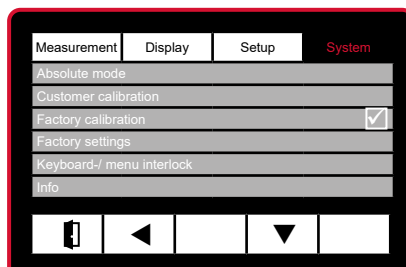

- Select the **Absolute mode** submenu with ▼ and press ✓ to confirm

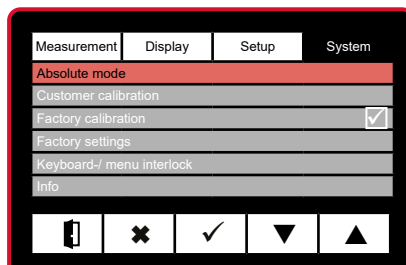

- Mechanically set probe to “0”
- Press the ►◀ and ◀► keys to adjust the scale
- Press ✓ to confirm
- Press the ON / OFF key to exit the input menu.

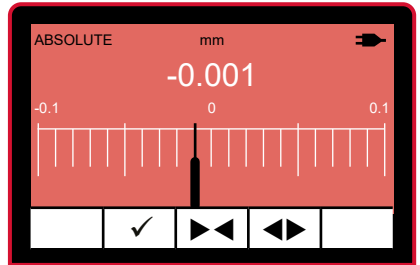

2.10 Switching OFF

- ! It is not possible to switch off the measuring instrument by pressing the ON / OFF key in the **Input menu**.
- Exit the **Input menu** to switch off the measuring instrument.
- => The **Analog display** will appear on the screen
- Press and hold the ON / OFF key >2 seconds.

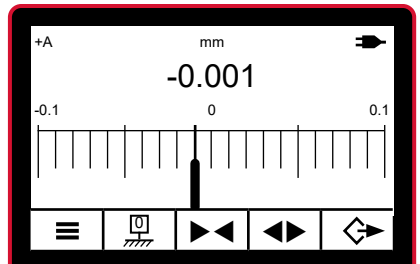

3. Measurement menu

3.1 Selecting the master

– Press the ON / OFF key



=> **Standard menu** appears

– Press ▼ ▲ to select the **Master** submenu

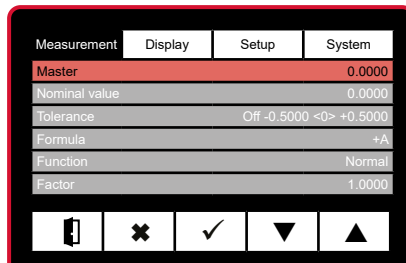

– Press ✓ to confirm

– Press ▼ ▲ to select the required **sign (+/-)**

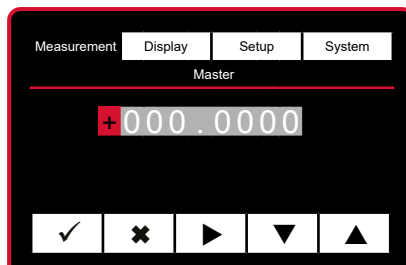

– Select the next position (digit) with the ► key

– Press ▼ ▲ to enter the required value

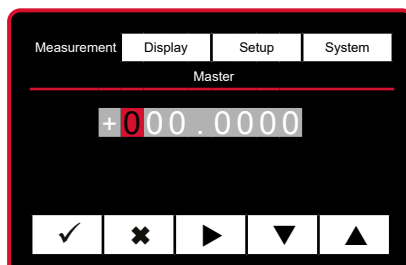

– Press the ✕ key for more than two seconds to reset the input to "0".

– Press ✓ to confirm or ✕ to cancel the selection

– Press the ON / OFF key to exit the input menu.



3.2 Selecting the nominal value

- Press the ON / OFF key

=> **Standard menu** appears



- Press ▼ ▲ to select the **Nominal value** submenu

- Press ✓ to confirm

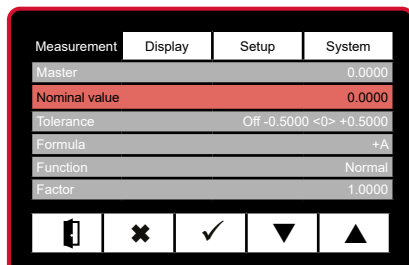

- Press ▼ ▲ to select the required **sign (+/-)**

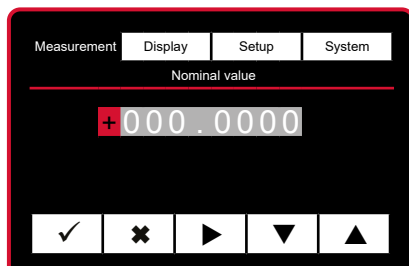

- Select the next position (digit) with the ► key

- Press ▼ ▲ to select the required **value**

- Press the ✕ key for more than two seconds to reset the input to "0".

- Press ✓ to confirm or ✕ to cancel the selection

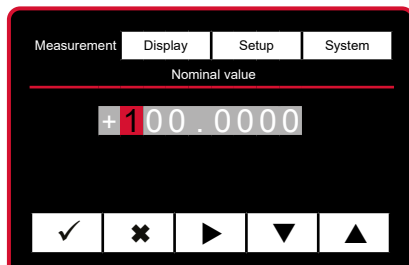

- Press the ON / OFF key to exit the input menu.



3.3 Selecting the tolerance

– Press the ON / OFF key



=> **Standard menu** appears

– Press ▼ ▲ to select the **Tolerance** submenu

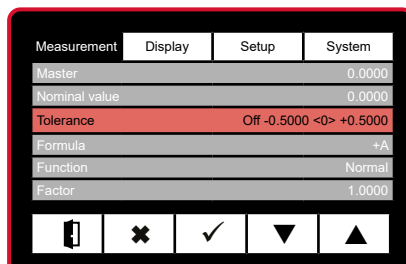

– Press ✓ to confirm

– Press ▼ to select **Tolerance On** and press ✓ to confirm or ✘ to exit the menu

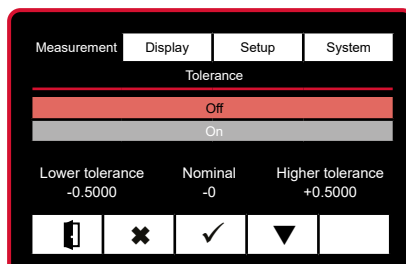

– Enter **Lower tolerance** value

– Press ▼ ▲ to enter the required **sign (+/-)**

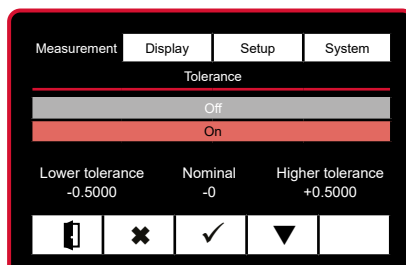

– Press ► to continue

– Press ▼ ▲ to enter the required **value**

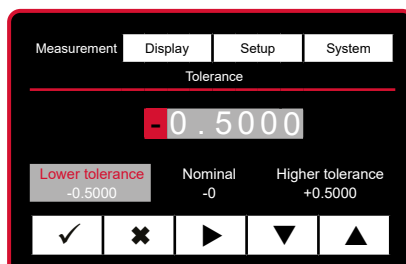

– Press ✓ to confirm or ✘ to cancel the selection

- Enter a value for the **Higher tolerance**
- Press ▼ ▲ to enter the required **sign (+/-)**
- Press ► to continue
- Press ▼ ▲ to enter the required **value**
- Press ✓ to confirm or ✘ to cancel the selection
- Press the ON / OFF key to exit the input menu.

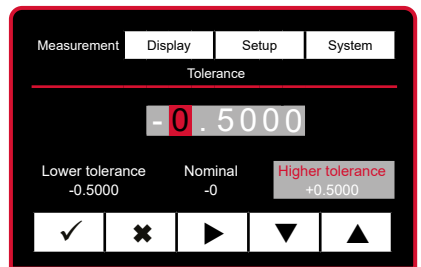
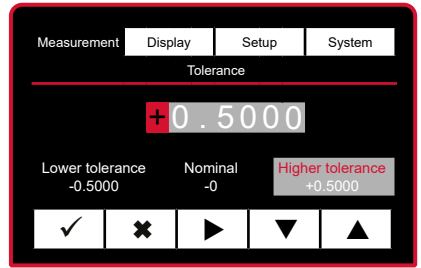

3.4 Selecting the formula

– Press the ON / OFF key

=> **Standard menu** appears



– Press ▼ to select the **Formula** submenu

– Press ✓ to confirm



– Press ▼ ▲ to select **+A / -A**

– Press ✓ to confirm or ✕ to cancel the selection

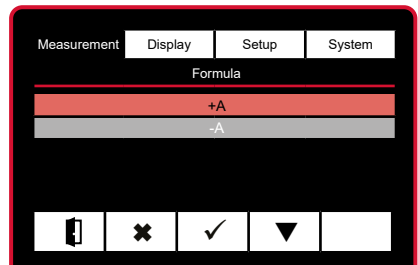

– Press the ON / OFF key to exit the input menu.



3.5 Selecting the function

- Press the ON / OFF key

=> **Standard menu** appears



- Press ▼ to select the **Function** submenu

- Press ✓ to confirm

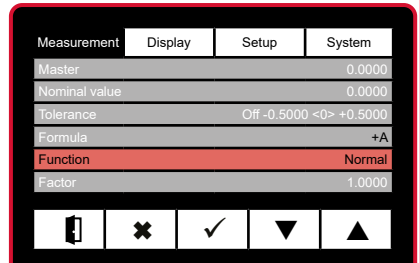

- Press ▼ ▲ to select the required **Function**

- Press ✓ to confirm or ✘ to cancel the selection

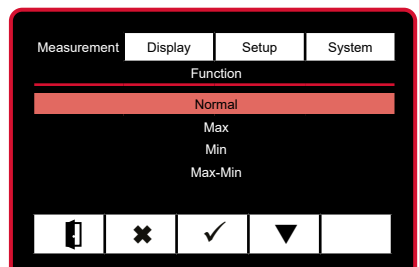

- Press the ON / OFF key to exit the input menu.



3.6 Selecting the factor

– Press the ON / OFF key

=> **Standard menu** appears



– Press ▼ to select the **Factor** submenu

– Press ✓ to confirm

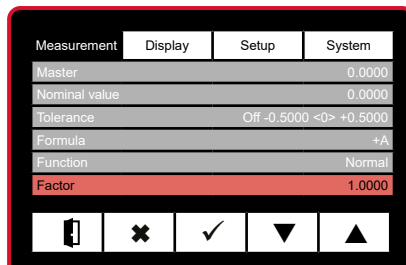

– Press ▼ ▲ to enter the required **value**.

– Press ✓ to confirm the value or ✕ to exit the menu

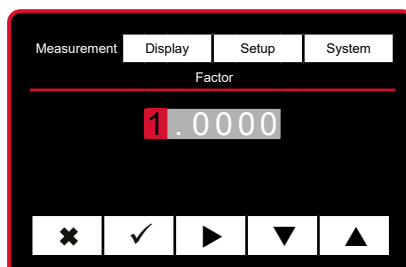

– Press the ON / OFF key to exit the input menu.



4. Display menu

4.1 Selecting the resolution

– Press the ON / OFF key

=> **Standard menu** appears

– Press ► to select the **Display** menu

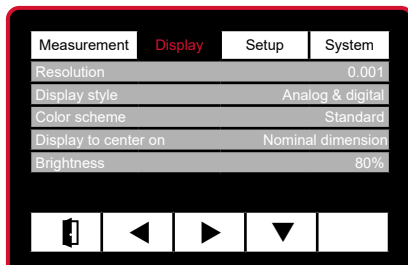

– Press ▼ to select the **Resolution** submenu

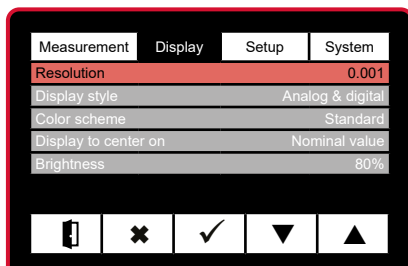

– Press ✓ to confirm

– Press ▼▲ to select the required **Resolution**

– Press ✓ to confirm or ✕ to cancel the selection

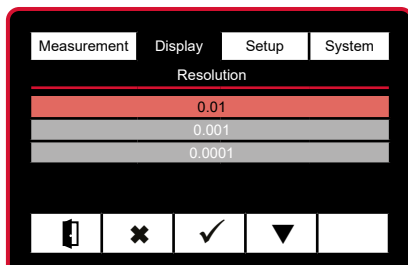

– Press the ON / OFF key to exit the input menu.

4.2 Selecting the display style

– Press the ON / OFF key

=> **Standard menu** appears



– Press ► to select the **Display** menu

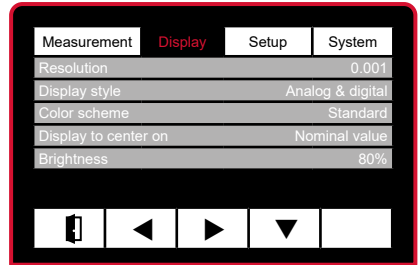

– Press ▼ to select the **Display style** submenu

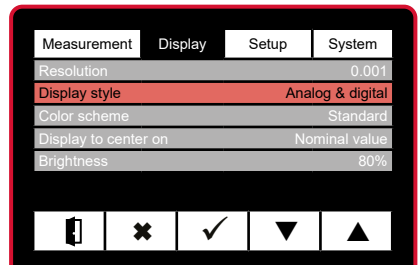

– Press ✓ to confirm

– Press ▼ ▲ to select the required **Display style**

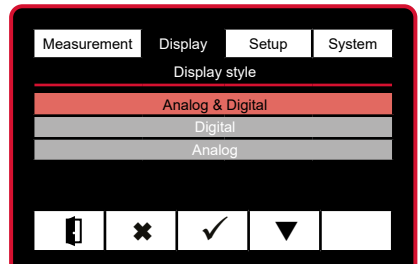

– Press ✓ to confirm or ✕ to cancel the selection

– Press the ON / OFF key to exit the input menu.



4.3 Selecting the color scheme

- Press the ON / OFF key

=> **Standard menu** appears



- Press ► to select the **Display** menu

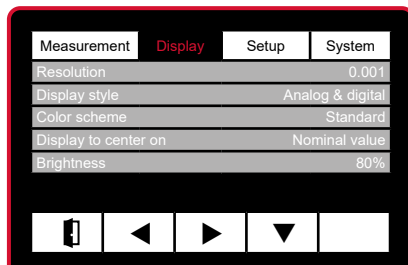

- Press ▼ to select the **Color scheme** submenu

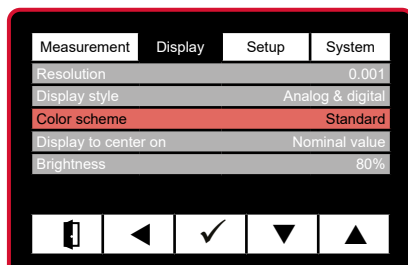

- Press ✓ to confirm

- Press ▼▲ to select the required **Color scheme**

- Press ✓ to confirm or ✘ to cancel the selection

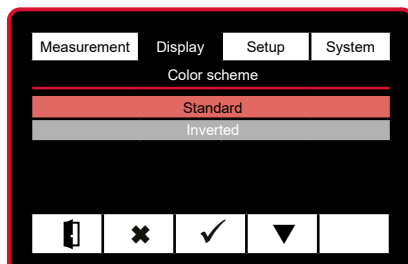

- Press the ON / OFF key to exit the input menu.



4.4 Centering the display

– Press the ON / OFF key

=> **Standard menu** appears



– Press ► to select the **Display** menu

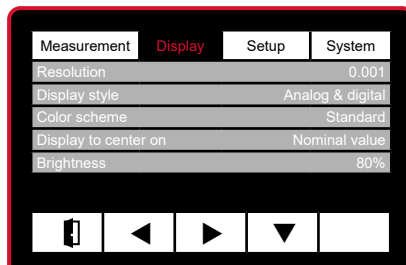

– Press ▼ to select the **Center display** to submenu

– Press ✓ to confirm

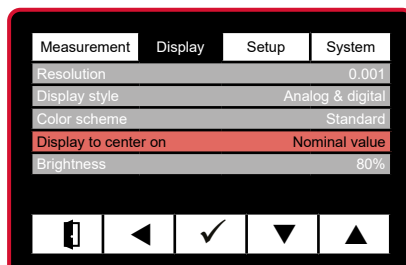

– Press ▼ ▲ to select the required **Centering**

 With asymmetric tolerances, the tolerance field can be displayed outside the scaled analog display. In this case, it is advisable to center the display to the center of the tolerance rather than to the nominal size.

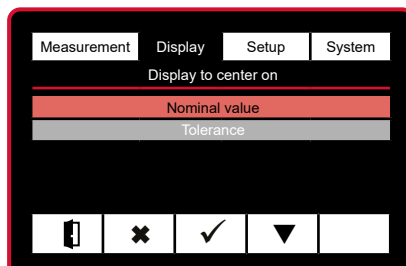

– Press ✓ to confirm or ✕ to cancel the selection

– Press the ON / OFF key to exit the input menu.



4.5 Setting the brightness

- Press the ON / OFF key

=> **Standard menu** appears



- Press **▶** to select the **Display** menu

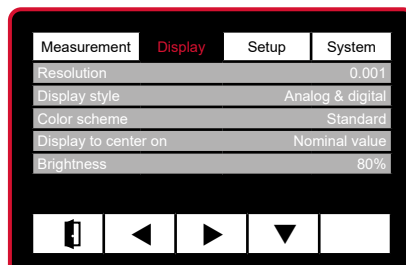

- Press **▼** to select the **Brightness** submenu

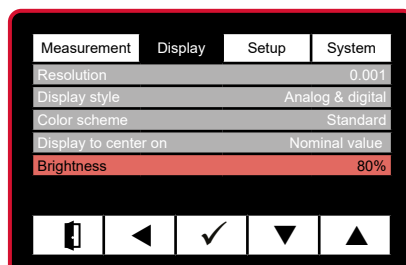

- Press **✓** to confirm

- Press **▼ ▲** to select the required **Brightness**

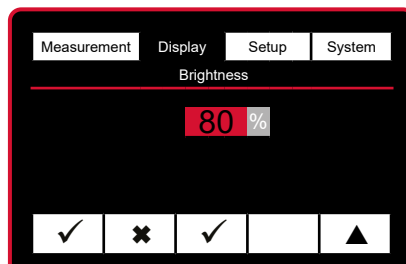

- Press **✓** to confirm or **✘** to cancel the selection

- Press the ON / OFF key to exit the input menu.



5. Setup menu

5.1 Selecting the display language

– Press the ON / OFF key



=> **Standard menu** appears

– Press ► to select the **Setup** menu

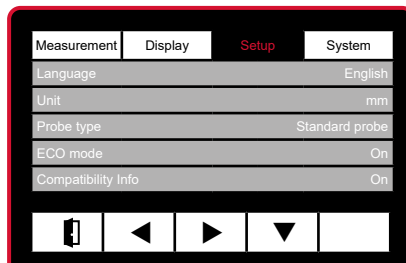

– Press ▼ to select the **Language** submenu

– Press ✓ to confirm

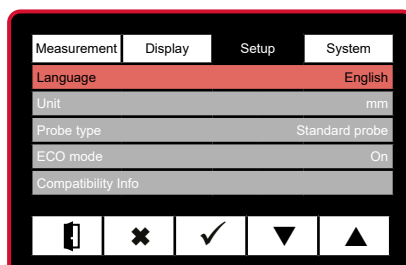

– Press ▼ ▲ to select the required **Language**

– Press ✓ to confirm or ✘ to cancel the selection

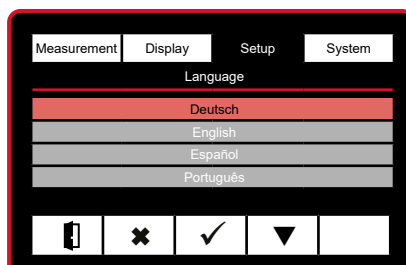

– Press the ON / OFF key to exit the input menu.



5.2 Selecting the unit of measurement

- Press the ON / OFF key



=> **Standard menu** appears

- Press ► to select the **Setup** menu

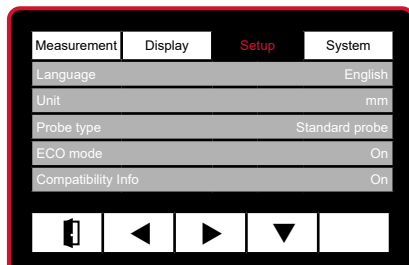

- Press ▼ to select the **Unit** submenu

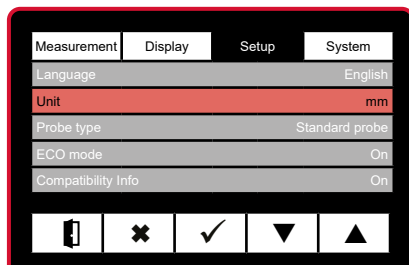

- Press ✓ to confirm

- Press ▼ ▲ to select the required **Unit**

- Press ✓ to confirm or ✕ to cancel the selection

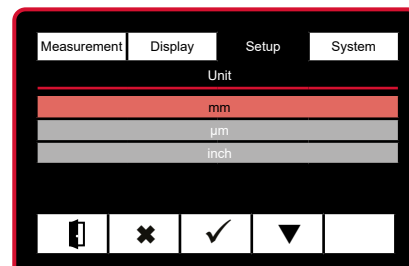

- Press the ON / OFF key to exit the input menu.





Only probe P2010 and its subtypes (P2010 A or B) are classified as **long probes**. All of the other types of inductive probes can be operated as **standard probes**.

5.3 Selecting the probe type

– Press the ON / OFF key

=> **Standard menu** appears

– Press ► to select the **Setup** menu

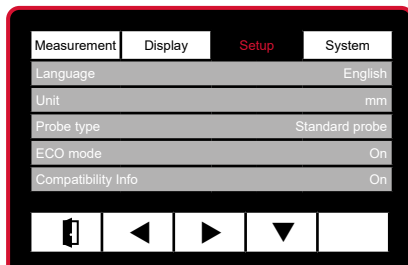

– Press ▼ to select the **Probe type** submenu

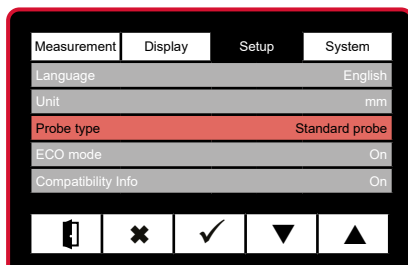

– Press ✓ to confirm

– Press ▼ ▲ to select the required **Probe type**

– Press ✓ to confirm or ✕ to cancel the selection

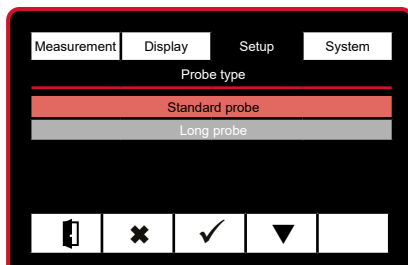

– Press the ON / OFF key to exit the input menu.

-  When **ECO mode** is activated, the time until the backlighting and screen are completely switched off is reduced. This is particularly advisable if the instrument is being operated with batteries.

5.4 Selecting ECO mode

- Press the ON / OFF key



=> **Standard menu** appears

- Press **▶** to select the **Setup** menu

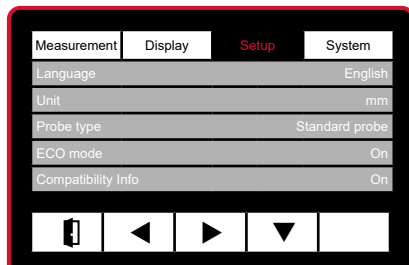

- Press **▼** to select the **ECO mode** submenu

- Press **✓** to confirm

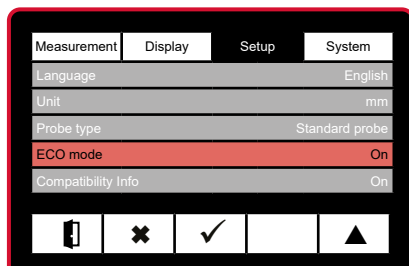

- Press **▼▲** to select the required **mode**

- Press **✓** to confirm or **✘** to cancel the selection

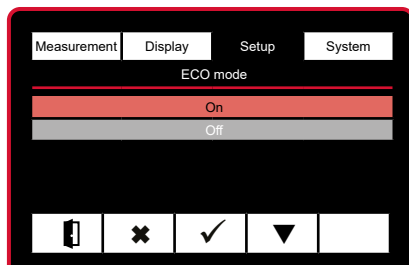

- Press the ON / OFF key to exit the input menu.



5.5 Compatibility information

 Note: The display appears for approx. 3 seconds after start-up when the device is switched on. This display can be activated or deactivated.

– Press the ON / OFF key

=> **Standard menu** appears

– Press **▶** to select the **Setup** menu

– Press **▼** to select the **Compatibility Info** submenu

– Press **✓** to confirm

– Press **▼ ▲** to select the required **Mode**

– Press **✓** to confirm or **✘** to cancel the selection

– Press the ON / OFF key to exit the input menu.

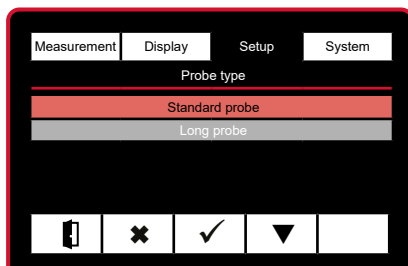
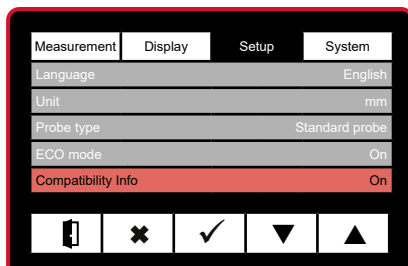
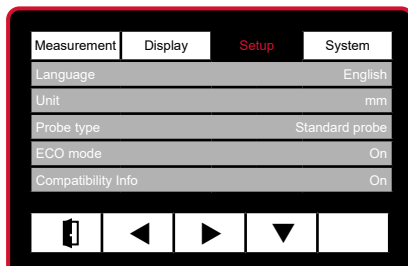

6. System menu

! *The device guarantees the highest accuracy after approx. 30 min operating time. The measuring probe should be mechanically set to the electrical zero point before the first measurement is conducted. Setting mode that indicates the raw value or absolute value of the probe should be used for this purpose.*

6.1 Selecting absolute mode

– Press the ON / OFF key



=> **Standard menu** appears

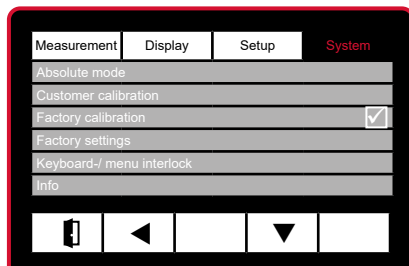

– Press **▶** to select the **System** menu

– Press **▼** to select the **Absolute mode** submenu

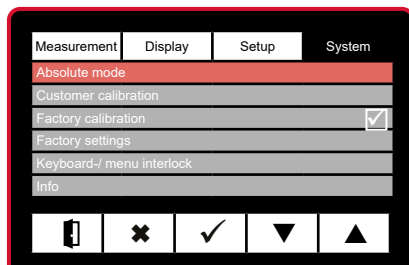

– Press **✓** to confirm

– Mechanically set probe to “0”.

– Press the **▶◀** and **◀▶** keys to adjust the scale

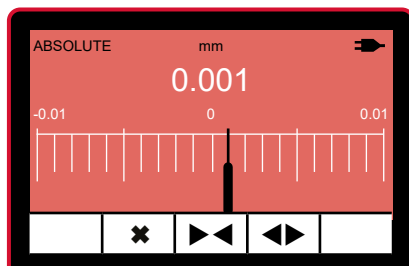

– Press **✓** to confirm

– Press the ON / OFF key to exit the input menu.





If a customer-specific calibration is required, this can be completed in the menus described in the following. The calibration can be completed with the connected probe or alternatively with a factory standard (e.g. Mahr 1283 WN Factory Calibration, Order no. 5312833).

6.2 Customer calibration



6.2.1 Enabling customer calibration

- Press the ON / OFF key

=> **Standard menu** appears

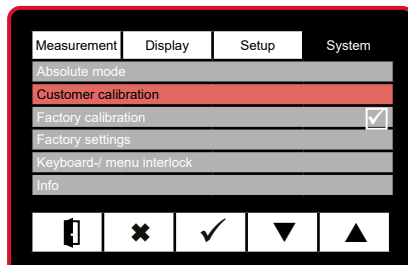

- Press ► to select the **System** menu

- Press ▼ to select the **Customer calibration** submenu

- Press ✓ to confirm

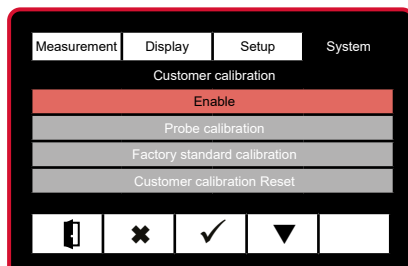

- Press ▼ to select the **Enable** submenu

- Press ✓ to confirm or ✕ to cancel the selection

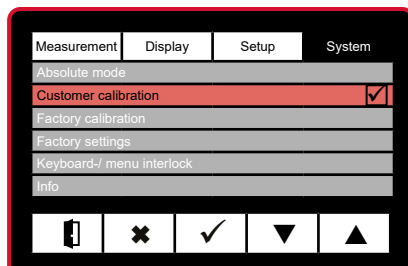

=> The ✓ symbol indicates the currently active calibration

- Press the ON / OFF key to exit the input menu.



 The device guarantees the highest accuracy after approx. 30 min operating time. To conduct a reliable probe calibration, the calibration zero point that is going to be used must first be positioned to the electrical zero point via the raw value of the probe (see section 2.9, page 18). This is because the inductive probe measures most accurately at the electrical zero point. A 1.000 mm gage block would be the perfect electrical zero point for a probe calibration, like the one in this example, where a 2.000 mm gage block is used for the MAX value, the MIN value is obtained on a measuring plate.

6.2.2 Executing a probe calibration

- Press the ON / OFF key



=> **Standard menu** appears

- Press **▶** to select the **System** menu
- Press **▼** to select the **Customer calibration** submenu

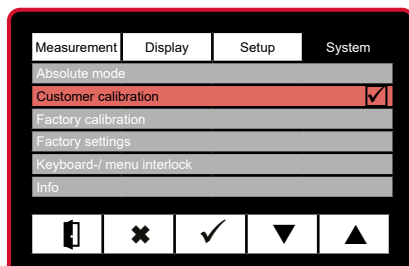

- Press **✓** to confirm

- Press **▼** to select **Probe calibration**

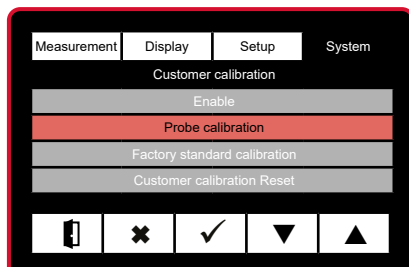

- Press **✓** to confirm or **✕** to cancel the selection

- Enter value for **Calibration Min** (e.g. -1.000 mm). Press **▶** to select the required digit and press **▼ ▲** to enter the required value.

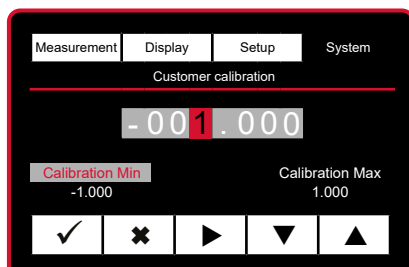

- Press **✓** to confirm or **✕** to cancel the selection

- Enter value for **Calibration Max** (e.g. +1.000 mm). Press ► to select the required digit and press ▼▲ to enter the required value.
- Press ✓ to confirm or ✘ to cancel the selection
- Move the **Probe** to the **Min** position (e.g. measuring plate)

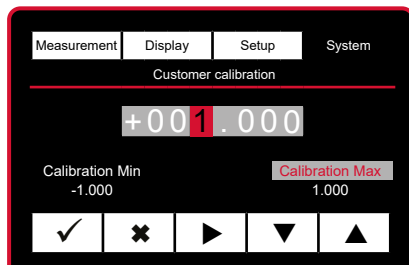

- => The following appears on the display:
Set probe to **Calibration Min** and accept

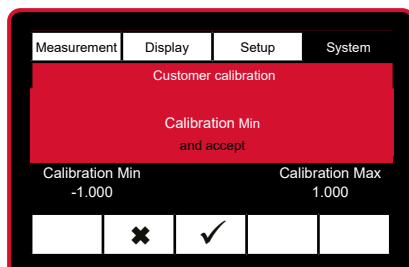

- Press ✓ to confirm

- Move the probe to the **Max** position (e.g. 2.000 mm gauge block)

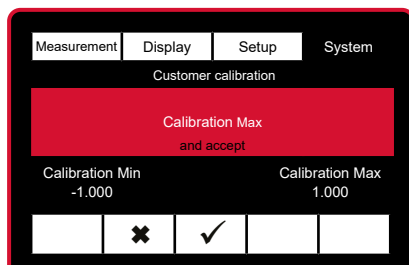

- => The following appears on the display:
Set probe to **Calibration Max** and accept

- Press ✓ to confirm

- => **Probe calibration** according to the customer's specification is complete and activated.

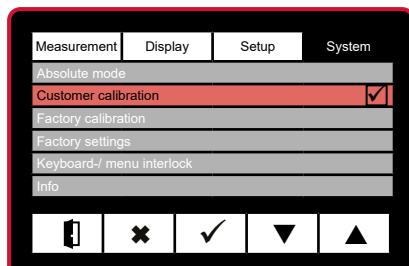

- Press the ON / OFF key to exit the input menu.



6.2.3 Conducting a factory standard calibration

- Press the ON / OFF key
- => **Standard menu** appears



- Press ► to select the **System** menu
- Press ▼ to select the **Customer calibration** submenu
- Press ✓ to confirm

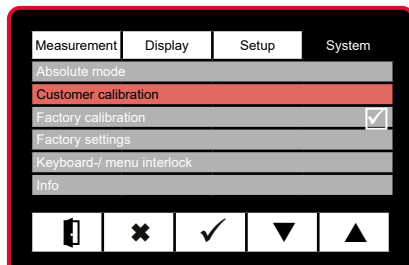

- Press ▼ to select **Factory standard calibration**

- Press ✓ to confirm or ✕ to cancel the selection

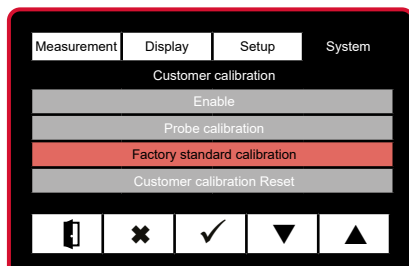

- Enter value for **Calibration Min** (e.g. -1.000 mm). Press ► to select the required digit and press ▼ ▲ to enter the required value.

- Press ✓ to confirm or ✕ to cancel the selection

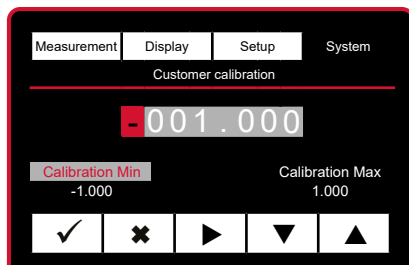

- Enter value for **Calibration Max** (e.g. +1.000 mm). Press ► to select the required digit and press ▼▲ to enter the required value.
- Press ✓ to confirm or ✕ to cancel the selection

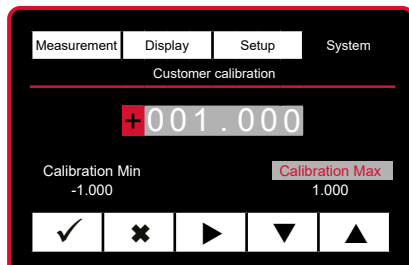

- Connect the jumpers to the **Factory standard** as illustrated

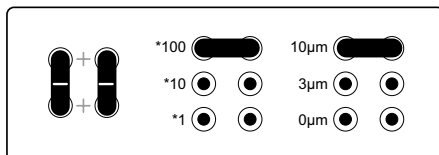

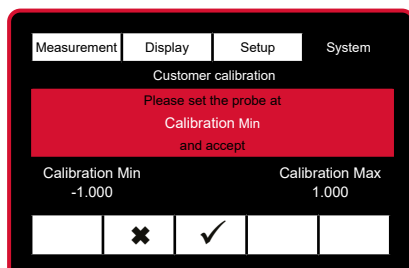

The following appears on the display:
Set probe to **Calibration Min** and accept

- Press ✓ to confirm

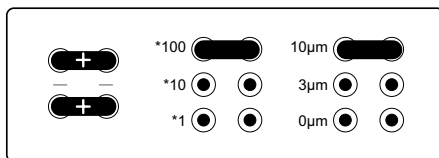

- Connect the jumpers to the **Factory standard** as illustrated



 Continue with the calibration of probes.
The calibration of Mahr probes is detailed on page 44, the calibration of TESA probes on page 43.



For TESA probes, the minimum and maximum adjustable value for calibration is 300 μm . The TESA adapter cable 7026704 must be connected between the Millimar C1200 and the TESA probe. The display shows the value 784.4 mm

- Enter value for **Calibration Min** (e.g. -300 μm). Press **▶** to select the required digit and press **▼▲** to enter the required value.

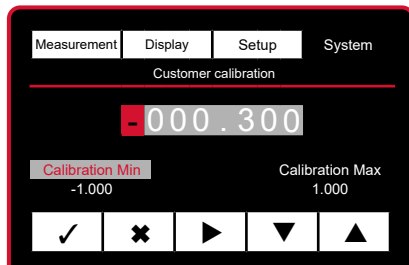

- Press **✓** to confirm or **✘** to cancel the selection

- Enter value for **Calibration Max** (e.g. +300 μm). Press **▶** to select the required digit and press **▼▲** to enter the required value.

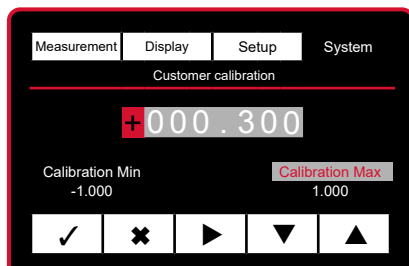

- Press **✓** to confirm or **✘** to cancel the selection

- Connect the jumpers to the **Factory standard** as illustrated

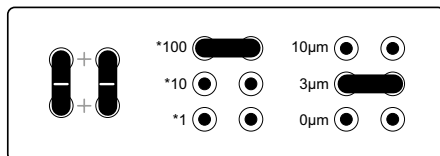

The following appears on the display:

Set probe to **Calibration Min** and accept

- Press **✓** to confirm

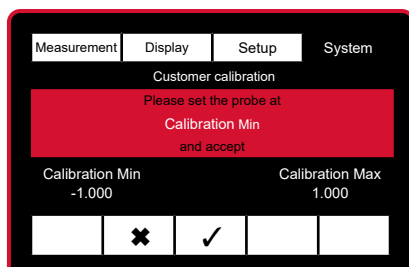

- Connect the jumpers to the **Factory standard** as illustrated

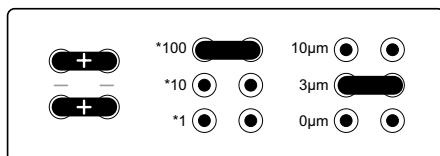

The display shows:
Set button to **Calibration Max**
and accept

- Press ✓ to confirm

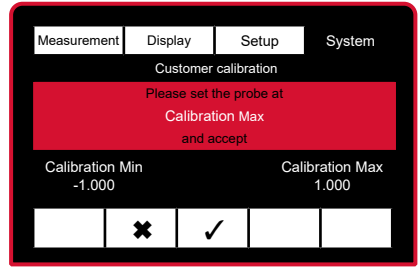

- Connect the jumpers to the **Factory standard** as illustrated

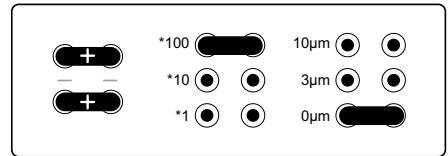

- => The following appears on the display:
Set probe to "0" and accept

- Press ✓ to confirm

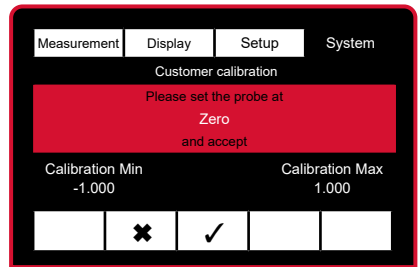

- => **Factory standard calibration** according to the customer's specifications is complete and activated

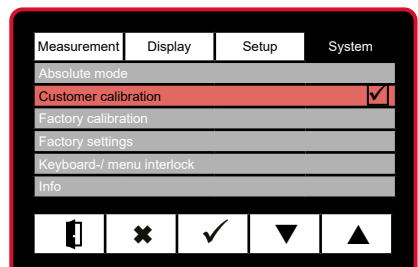

- Press the ON / OFF key to exit the input menu.



6.2.4 Executing a customer calibration reset

- Press the ON / OFF key
- => **Standard menu** appears



- Press ► to select the **System** menu
- Press ▼ to select the **Customer calibration** submenu
- Press ✓ to confirm

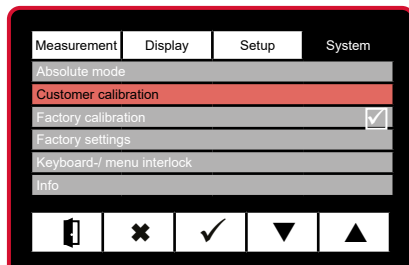

- Press ▼ to select **Customer calibration Reset**

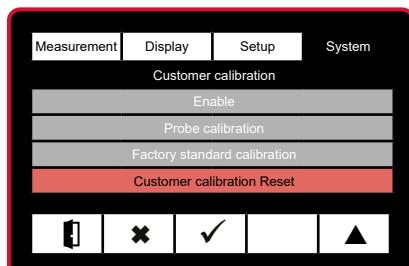

- Press ✓ to confirm or ✕ to cancel the selection

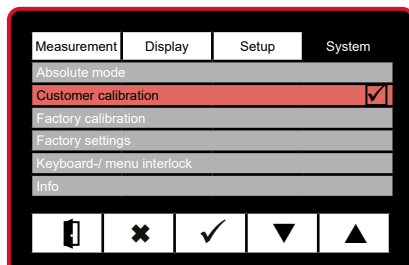

- Press the ON / OFF key to exit the input menu.



-  To avoid any measurement errors, that may be caused by a previously created customer calibration, it is advisable to implement the factory standard calibration. This is always stored in the measuring instrument and is not changed by the customer calibration.

6.3 Activating a factory calibration

- Press the ON / OFF key

=> **Standard menu** appears



- Press **▶** to select the **System** menu

- Press **▼** to select the **Factory calibration** submenu

- Press **✓** to confirm

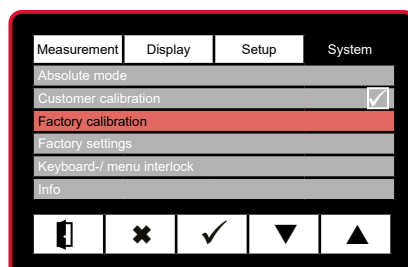

- Press **▼** to select the **Enable** menu

- Press **✓** to confirm or **✘** to cancel the selection

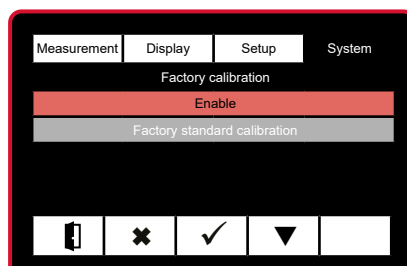

- The **✓** symbol indicates the currently active calibration

- Press the ON / OFF key to exit the input menu.

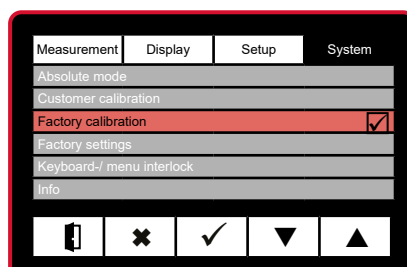

6.4 Resetting to factory settings

- Press the ON / OFF key

=> **Standard menu** appears



- Press ► to select the **System** menu

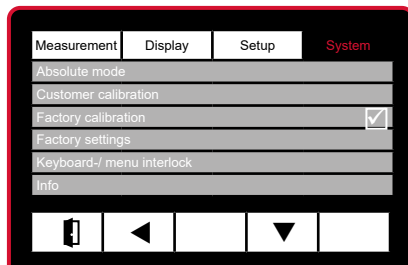

- Press ▼ to select the **Factory settings** submenu

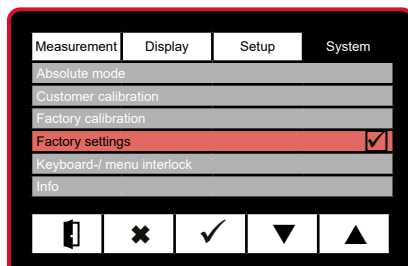

- Press ✓ to confirm

! If **Yes** is selected, all of the settings are reset to the factory settings.

- Press ✓ to confirm or ✕ to cancel the selection

=> The measuring instrument switches off automatically. All of the default settings must be entered again after the restart (see Initial operation, page 14).

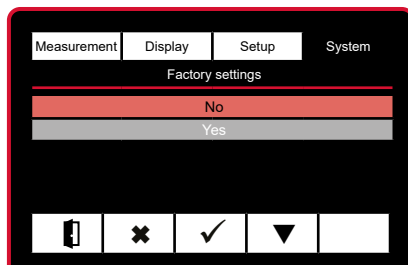

6.5 Activating the menu lock

– Press the ON / OFF key

=> **Standard menu** appears



– Press ► to select the **System** menu

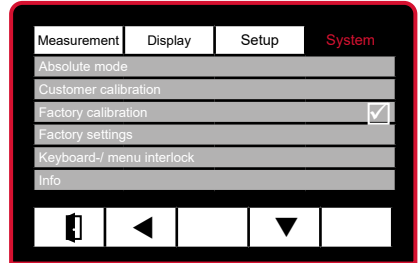

– Press ▼ to select the **Keypad/ menu lock** submenu

– Press ✓ to confirm

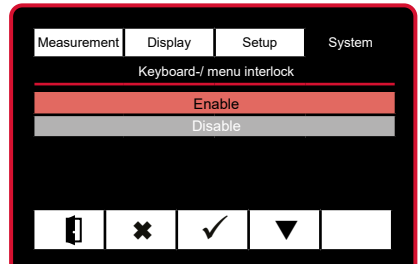

– Press ▼ to select **Enable** or **Disable**

– Press ✓ to confirm the selection and press ✕ or select **Disable** to cancel.

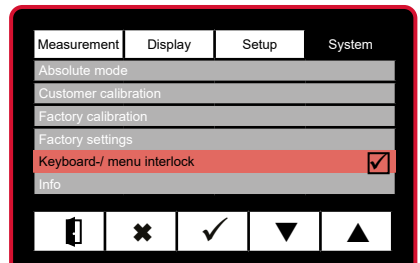

- Press ▼ ▲ to enter the first number of the pin and/or press ► to move to the next digit.

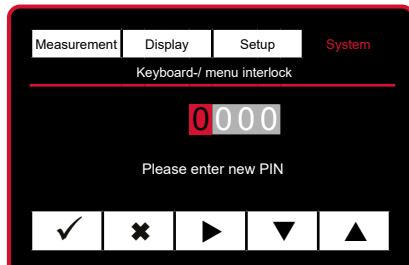

- Press ▼ ▲ to enter the second number of the pin and/or press ► to move to the next digit.

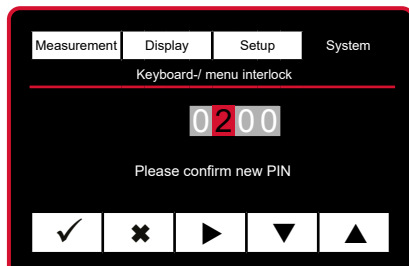

- Press ✓ to confirm or ✕ to cancel the selection

=> When the pin is activated, the user will be asked to enter the pin every time the menu is displayed.

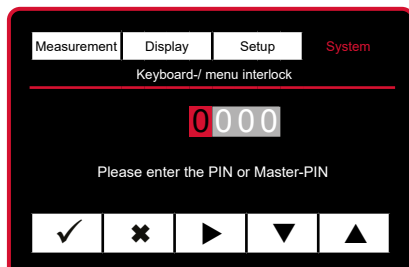

=> The following will appear if an incorrect pin is entered

- Press ✓ to confirm.
- Enter correct pin again and confirm by pressing ✓

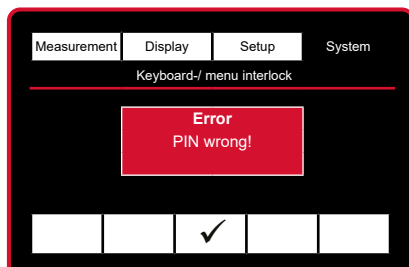

=> If you have forgotten the pin, you can request the master pin from the product management team at Mahr GmbH.

6.6 Requesting firmware version and serial number

– Press the ON / OFF key

=> **Standard menu** appears



– Press ► to select the **System** menu

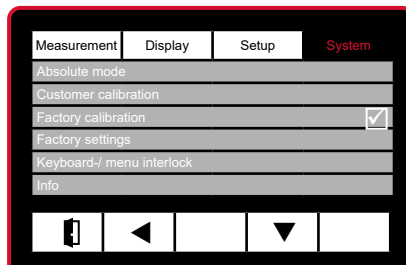

– Press ▼ to select the **Info** submenu

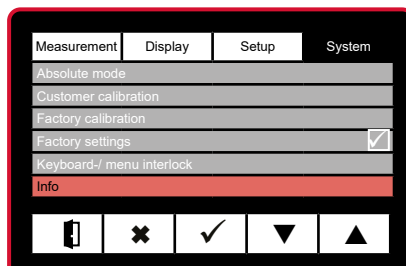

– Press ✓ to confirm.

=> The firmware version and serial number are displayed

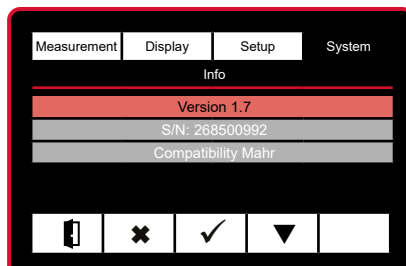

👉 The display appears for approx. 3 seconds after start-up. This display can be activated or deactivated.

– Press ✖ to exit the menu

– Press the ON / OFF key to exit the input menu.



7. Description of the interfaces

7.1 Suitable data connection cables

- Opto RS232C (2 m), SUB-D jack, 9-pin Order no. 4346020
- Digimatic (2 m), SUB-D jack, 9-pin Order no. 4346021
- 2000 USB (2 m), incl. MarCom Standard Order no. 4346023
- 2000 e wireless transmission module Order no. 4102232
- e-Stick wireless receiver incl. MarCom Standard Order no. 4102230

7.2 Interfaces: Opto RS232C, Digimatic, USB

Digimatic Datenkabel
Bestell-Nr.: 4346021

PIN No.		
1	GND	
2	DATA	Out
3	CLOCK	Out
4	READY	Out
5	REQUEST	In
6		
7		
8		
9		
10		

Digimatic Data cable
Order no.: 4346021

Digimatic

Digimatic

- Ausgabe in µm nicht möglich
- Ausgabe in inch mit .000005 Auflösung nicht möglich

Digimatic

- Output in µm not possible
- Output in inch with .000005 resolution not possible

Opto RS232C duplex
Datenkabel
Bestell-Nr.: 4346020

PIN No.		
1		
2	Txd	Out
3	Rxd	In
4	V+	
5		
6		
7	V-	
8		
9		

Opto RS232C duplex
Data cable
Order no.: 4346020

Opto RS232C

USB

Virtueller COM-Schnittstellentreiber:
Die Treiber und Beschreibung sind im Lieferprogramm des Kabels 2000 USB enthalten.

Der Treiber emuliert für jedes angeschlossene Kabel einen zusätzlichen virtuellen Com-Port. Die Anwendungssoftware kommuniziert darüber mit dem Gerät in der gleichen Weise wie mit einem Hardware Com-Port.

Aktuelle Treiber finden Sie auf unserer Internetseite:
www.mahr.com

Virtual COM-Interface-Driver:
The Driver and instructions are supplied with a 2000 USB cable.

The Driver emulates for every connected cable an additional virtual COM-Port. The application software communicates to the instrument in exactly the same manner as a normal hardware COM-Port.

The actual Driver can be found on our website: www.mahr.com

Duplex operation

PC-side

? CR

TxD

RxD

Power supply
DTR = "High" level
RTS = "Low" level

7.3 Data transmission parameters

Description	Command (_, * corresponds to a space)?	Command example (_, * corresponds to a space)	Reply (_, * corresponds to a space)	Permissible entry value	Notes
Request measuring value	?		XXXXXX XXXXXX< XXXXXX= XXXXXX>	-	- Reply dependent on measuring unit and resolution - If tolerance mode is enabled, the current tolerance state is indicated by the following symbols: = : Within the tolerance < : Below the tolerance > : Above the tolerance
Request instrument designation	ID?		C1200	-	-
Request version number	VER?		XX	-	-
Change measuring unit to mm	UM		UM	-	-
Change measuring unit to inch	IM		IM	-	-
Change measuring direction to +A	CHA+		CHA+	-	-
Change measuring direction to -A	CHA-		CHA-	-	-
Switch device OFF	OFF		OFF	-	-
Execute master measurement	RST		RST	-	-
Enter factor	FAC_<factor>	FAC_2.5	FAC	0.0001 to 10.0000 -> max. 4 decimal places	-
Request factor	FAC?		X.XXXX	-	-
Enter master	MASTER_<master>	MASTER_500	MASTER	In mm = -999.990 to +999.990 -> max. 4 decimal places In µm = -999990.0 to +999990.0 -> max. 1 decimal place In inch = -39.369685 to +39.369685 -> max. 6 decimal places	- Reply dependent on measuring unit and resolution
Request master	MASTER?		±XXXXXX	-	-
Enter nominal value	NOMINAL_<nominal>	NOMINAL_500	NOMINAL	In mm = -999.990 to +999.990 -> max. 4 decimal places In µm = -999990.0 to +999990.0 -> max. 1 decimal place In inch = -39.369685 to +39.369685 -> max. 6 decimal places	- Reply dependent on measuring unit and resolution - Reply dependent on measuring unit and resolution
Request nominal value	NOMINAL?		±XXXXXX	-	-
Deactivate tolerance mode	TOL0		TOL0	-	-
Enable tolerance mode	TOL1		TOL1	-	-
Enter higher and lower limit value	TOL_<higher- To>_<lowerTo>	TOL_300_-300	TOL	<higherTo> or <lowerTo>: In mm = -5.0000 to +5.0000 -> max. 4 decimal places In µm = -5000.0 to +5000.0 -> max. 1 decimal place In inch = -0.196850 to +0.196850 -> max. 6 decimal places	The input value for the <higherTo> must be greater than the input value for the <lowerTo>
Request limit values	TOL?		±XXXXXX_±XXXXXX	-	-
Factory settings	FSET			-	- Instrument must be switched on again manually
Request serial number	SN?		YYMMXXXX	-	-
Deactivate serial number output	SNO		SNO	-	-
Activate serial number output	SNI		SNI	-	-
Enter resolution	RES_<resolution>	RES_3	RES	Resolution = (1, 2, 3)	mm µm inch RES_1 0.01 1 0.0001 RES_2 0.001 0.1 0.00001 RES_3 0.0001 0.1 0.000005
Request resolution	RES?		1 2 3	-	-
Request calibration factor	CCALF?		+/- XX.XXXXXX	-	-
Set calibration factor	CCALF_<factor>	CCALF_3.1234	CCALF_3.1234000	-	The customer calibration must be activated in the instrument following input of the calibration factor CCALF

8. Technical data

8.1 Compact length measuring instrument Millimar C 1200 M/T

Product type:	C 1200 M	C 1200 T
Order no.	5312012	5312011
Compatibility:	Mahr	Tesa
Display:	TFT color display, 4.3 inch, 480 (W) x 272(H) Pixel	
Keypad:	Membrane keypad, 1 million actuations	
Units :	µm, mm, inch	
Range of digital display (digital):	± 5000 mm	
Range of analog display (analog):		

Measuring range / µm	±5000	±2000	±1000	±300	±100	±30	±10	±3
Measuring range / mm	±5	±2	±1	±0.3	±0.1	±0.03	±0.01	±0.003
Measuring range / inch	±0.19	±0.07	±0.03	±0.01	±0.003	±0.001	±0.0003	±0.0001
Dial graduation / µm	500	200	100	20	10	2	1	0.2

Resolution:	
µm:	10; 1; 0,1
mm:	0,01; 0,001; 0,0001
inch:	0,0001; 0,00001; 0,000005
Tolerance display:	Background color: green/red
Measuring ranges, inductive probe:	± 1mm, ± 2mm, ± 5mm
Probe inputs:	1
Data transmission rate:	30 values per second
Measuring combinations:	+A / -A
Measuring functions:	Normal, Max, Min, Max-Min
Features:	1
Refresh rate:	40 fps (frames per second)
error limit, digital display:	0.2 µm or 0.3% of the displayed probe value *
* <i>The larger value applies</i>	
Error limit, analog display:	0.25% of the end scale value / 0.3% of the displayed value*
* <i>The larger value applies</i>	
Data interface:	Digimatic, Opto RS232C, USB, optional wireless transmission
Power supply :	Mains powered 100 -230 Volt / 7.5 V, 1.7 A (4102060) or battery / rechargeable battery
Battery / rechargeable battery type:	AA cells, 1,2 to 1,5 Volt
Operating time with battery / rechargeable battery:	> 8 h **
** <i>Dependent upon the capacity of the batteries / rechargeable batteries used, the brightness of the screen and the ECO Mode settings. With dynamic measurements displayed, the indicated operating time will be shorter.</i>	
IP protection class:	42
Weight without / with batteries:	496/620 g
Working temperature range:	10 °C – 35 °C
Operating temperature range:	0 °C – 40 °C ***
Storage temperature range:	-10 °C – 60 °C
Dimensions W/H/D:	Angle of the display - 0 degrees: 128.8/58.9/151 mm Angle of the display - 90 degrees: 128.8/166.9/150 mm
Distance between mounting holes:	65.5 mm

*** To achieve the highest accuracy, the device must warm up for operation. The operating temperature is reached approximately 30 minutes after switch on. According to ISO 1, the specifications for accuracy refer to a room temperature of 20°C.

8.2 Compatible probes for Millimar C 1200

C1200 M	
5312012	
Mahr - Compatibility	
Standard probe	
Carrier frequency	19.4 kHz
Sensitivity	192 mV/V/mm
Amplitude	5 Veff
Type	Order no.
1301	5313010
1303	5313030
1304K	5313049
1318	5313180
P1300MA	4400180
P1300MB	4400181
P2001M	5323040
P2004M	5323010
P2004MA	5323020
P2004MB	5323030
P2104MA	5324070
P2104MB	5324080
Long probe	
Carrier frequency	19.4 kHz
Sensitivity	19.2 mV/V/mm
Amplitude	5 Veff
Type	Order no.
P2010M	5324010
P2010MA	5324020
P2010MB	5324030

C1200 T	
5312011	
TESA - Compatibility	
Standard probe	
Carrier frequency	13 kHz
Sensitivity	73.75 mV/V/mm
Amplitude	3 Veff
Type	Order no.
P1300TA	4400190
P1300TB	4400191
P2004T	5323011
P2004TA	5323021
P2004TB	5323031
P2104TA	5324071
P2104TB	5324081
Long probe	
Carrier frequency	13 kHz
Sensitivity	29.5 mV/V/mm
Amplitude	3 Veff
Type	Order no.
P2010TA	5324021
P2010TB	5324031

9. Spare parts

9.1 Available spare parts

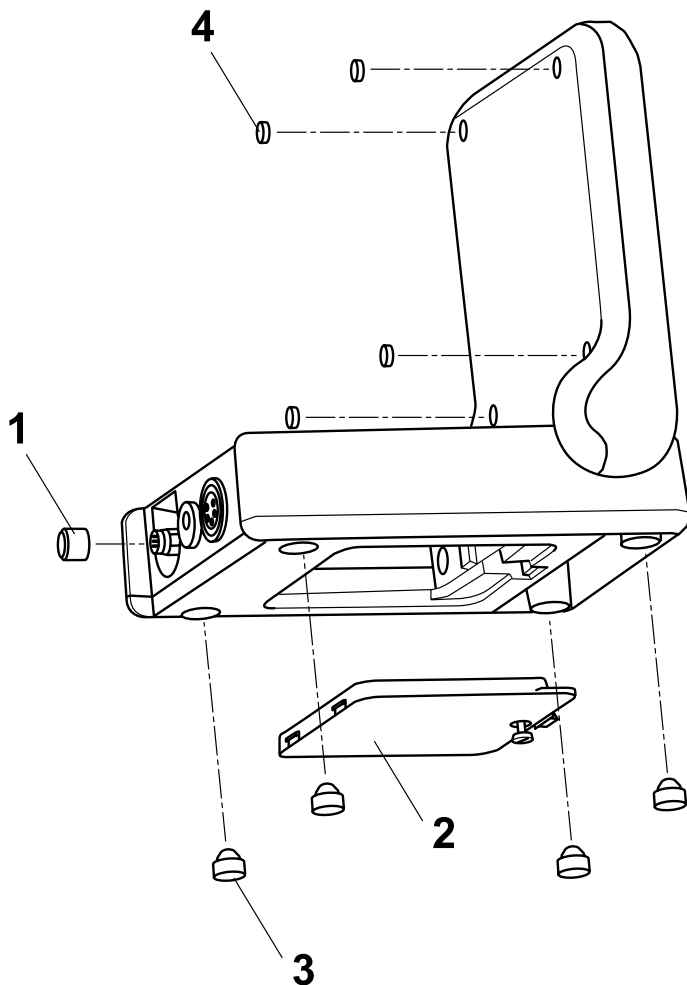

Item no.	Order no.	Contents (P.U.)	Designation
1	4346361-E	1	Screw top
2	4885431-E	1	Battery compartment cover incl. clamping screw
3	4885417-E	4	Plug-in housing feet
4	4885430-E	4	Elastic buffer, black, self-adhesive

